

DELINEATION FOR HORIZONTAL CURVES ON MULTI-LANE EXPRESSWAYS/FREEWAYS

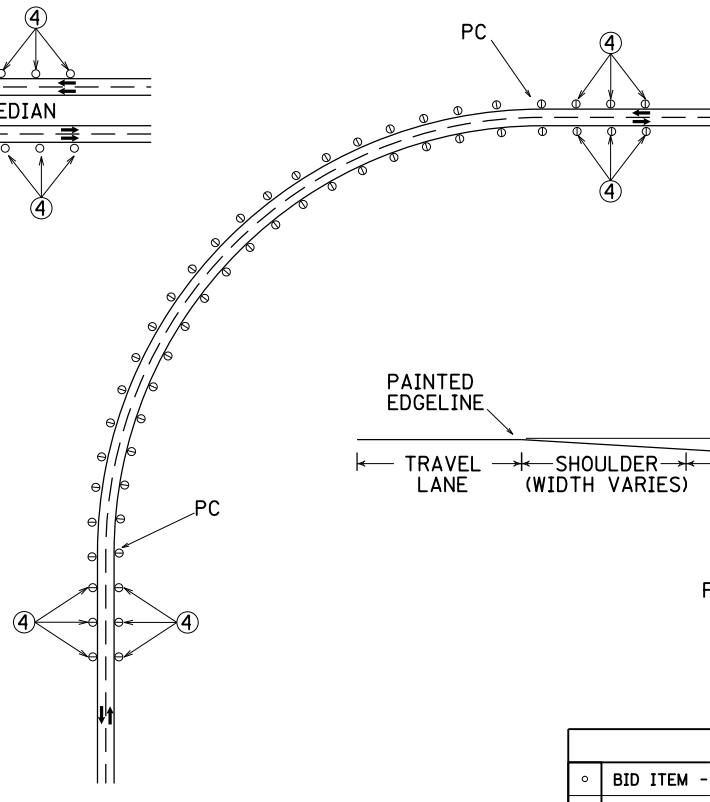

DELINEATION FOR HORIZONTAL CURVES ON TWO-LANE EXPRESSWAYS/FREEWAYS

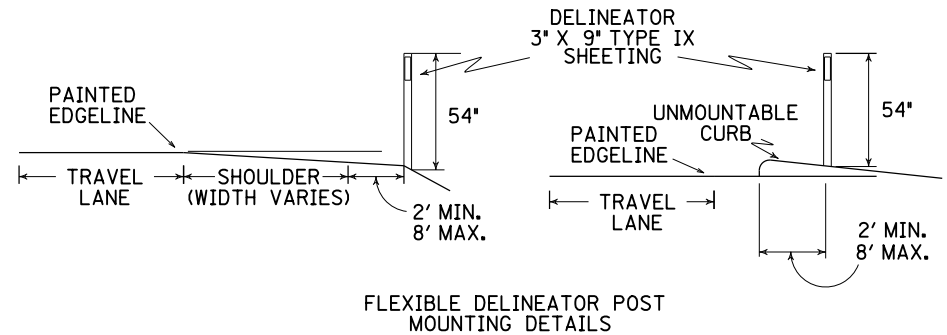

FLEXIBLE DELINEATOR POST MOUNTING DETAILS

LEGEND	
○	BID ITEM - FLEXIBLE DELINEATOR POST - M/W (MONO-WHITE)
⊙	BID ITEM - FLEXIBLE DELINEATOR POST - B/W (BI-WHITE)
APPROX. SPACING = 50 FEET	
UNIT BID = EACH	

~ NOTES ~

1. DELINEATORS SHALL BE FROM THE LIST OF APPROVED MATERIALS AND SHALL BE IN ACCORDANCE WITH SECTION 838 OF THE STANDARD SPECIFICATIONS FOR ROAD AND BRIDGE CONSTRUCTION, CURRENT EDITION.
2. DELINEATORS SHALL BE INSTALLED IN ACCORDANCE WITH THE MANUFACTURER'S RECOMMENDATIONS.
3. THE DELINEATOR POST AND RETROREFLECTIVE SHEETING SHALL BE THE SAME COLOR AND SHALL MATCH THE COLOR OF THE EDGELINES THEY SUPPLEMENT.
- ④ THREE DELINEATORS SHOULD BE INSTALLED IN ADVANCE OF THE BEGINNING AND PROCEEDING AWAY FROM THE END OF THE CURVE AT A SPACING OF APPROXIMATELY 50 FEET.
5. DELINEATORS SHALL BE PROVIDED ON THE RIGHT-HAND SIDE OF HORIZONTAL CURVES ON EXPRESSWAYS AND FREEWAYS. DELINEATORS ARE NOT REQUIRED ON TANGENT SECTIONS OF EXPRESSWAYS AND FREEWAYS.
6. A FREEWAY IS DEFINED AS A DIVIDED HIGHWAY WITH FULL CONTROL OF ACCESS. AN EXPRESSWAY IS DEFINED AS A DIVIDED HIGHWAY WITH PARTIAL CONTROL OF ACCESS.
7. DELINEATORS SHOULD BE PLACED AT A CONSTANT DISTANCE FROM THE ROADWAY EDGE. WHEN AN OBSTRUCTION EXISTS NEAR THE PAVEMENT EDGE, THE LINE OF DELINEATORS SHOULD BE TRANSITIONED TO THE INSIDE OF THE OBSTRUCTION OR TO THE BARRIER DELINEATION IF THE OBSTRUCTION IS GUARDRAIL OR BARRIER WALL. SUCH TRANSITIONS SHOULD BEGIN APPROXIMATELY 200 FT IN ADVANCE OF THE OBSTRUCTION/BARRIER.
8. DELINEATORS SHOULD BE INSTALLED AT AN APPROXIMATE RIGHT ANGLE TO APPROACHING TRAFFIC.
9. DELINEATORS MAY BE DISCONTINUED ALONG SECTIONS WITH BARRIER WALL OR GUARDRAIL DELINEATION.
10. SPACING SHOULD BE ADJUSTED IN CURVES SO THAT SEVERAL DELINEATORS ARE ALWAYS SIMULTANEOUSLY VISIBLE TO THE ROAD USER.

DRAWING NOT TO SCALE

<b>KENTUCKY</b>		
<b>DEPARTMENT OF HIGHWAYS</b>		
FLEXIBLE DELINEATOR POST ARRANGEMENTS FOR HORIZONTAL CURVES		
STANDARD DRAWING NO. TPM-170		
SUBMITTED	<i>B. Allen Wolf</i>	DATE 12-01-15
DIRECTOR, DIVISION OF DESIGN		DATE
APPROVED	<i>[Signature]</i>	DATE 12-01-15
STATE HIGHWAY ENGINEER		DATE