

SECTION A-A

~ NOTES ~

- BID ITEM AND UNIT TO BID  
MANHOLE TYPE B EACH
1. SEE CUR. STD. DWG. [RDM-105](#) FOR CASTINGS TO BE USED IN TRAFFIC AREAS AND CUR. STD. DWG. [RDM-100](#) FOR CASTINGS TO BE USED IN NON-TRAFFIC AREAS. THE MANHOLE MAY BE PRECAST CONCRETE PIPE SECTIONS OR CAST-IN-PLACE CONCRETE ⑥.
  - ② WHEN THE MANHOLE HEIGHT IS 25'-1\"/>
  - ③ THE NUMBER OF BARS DEPEND UPON HEIGHT OF BASE.
  - ④ LENGTH OF BARS DEPEND UPON HEIGHT. BAR LOCATIONS SHALL BE BENT AND/OR SHIFTED TO MISS PIPE.
  5. SEE PROPOSAL NOTES OR STANDARD SPECIFICATIONS FOR ADDITIONAL REQUIREMENTS.
  - ⑥ CAST-IN-PLACE MANHOLE LIMITATIONS: FROM 9'-1\"/>
  7. THE MAXIMUM SIZE OF INTERCEPTED PIPE SHALL BE 27\"/>
  - ⑧ SEE CUR. STD. DWG. [RDM-055](#) FOR STEP TYPE, SPACING AND DETAILS.

GRADE RING-CLASS "A" CONC.,  
PRECAST CONC., OR BRICK

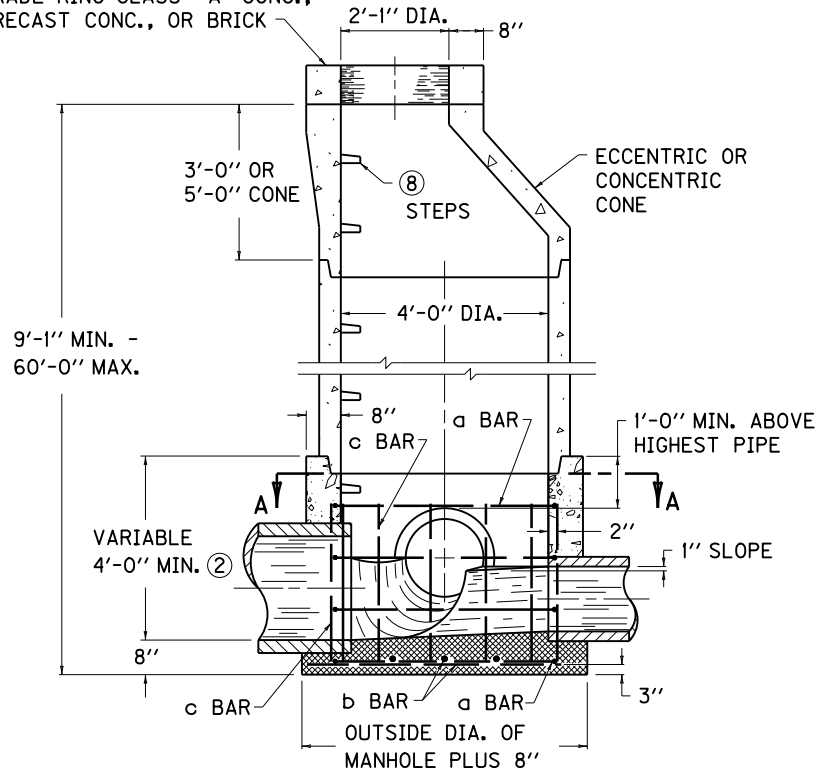

SECTIONAL ELEVATION

STEEL REINFORCEMENT

NO. 4 BAR	QTY.	LENGTH	SPACING	TYPE
a	③	13'-8"	APPROX.	CIR. 4'-4" DIA.
b	6	4'-6"	1'-0"	STR.
c	13	④	O.C.	STR.

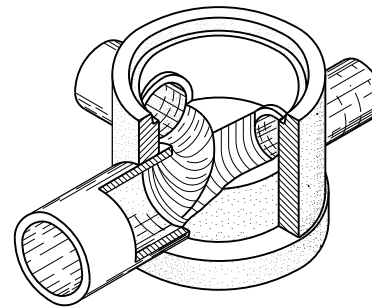

ISOMETRIC OF BASE

USE WITH CUR. STD. DWGS.  
[RDM-055](#), [RDM-100](#), [RDM-105](#)

KENTUCKY  
DEPARTMENT OF HIGHWAYS

MANHOLE  
TYPE B

STANDARD DRAWING NO. RDM-005-06

SUBMITTED *William P. Gullett* 12-01-15  
DATE  
APPROVED *[Signature]* 12-01-15  
DATE  
STATE HIGHWAY ENGINEER