

PLAN VIEW

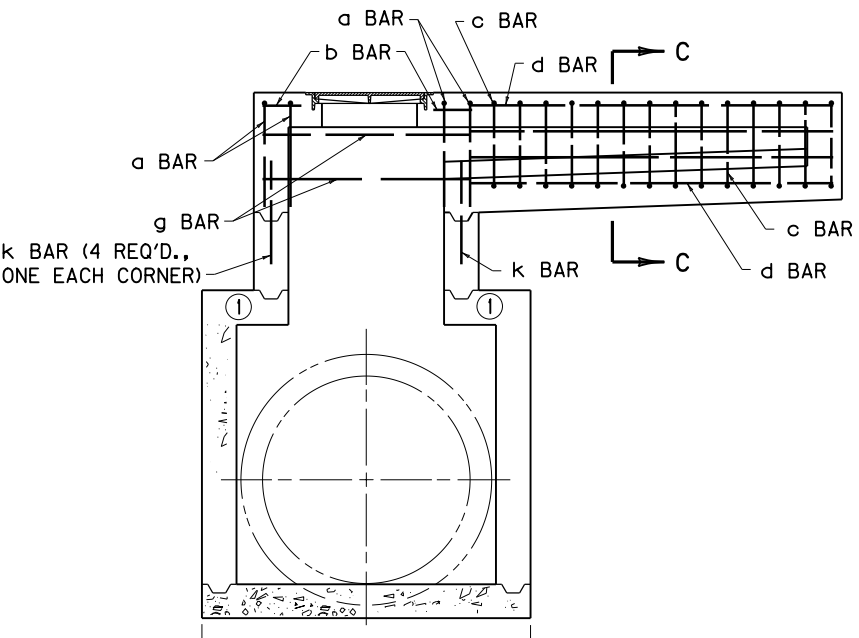

SECTION A-A

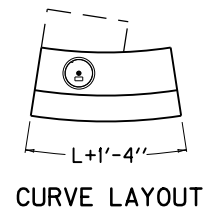
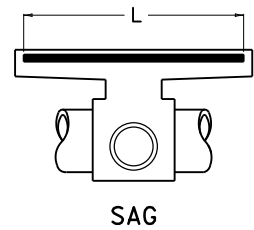
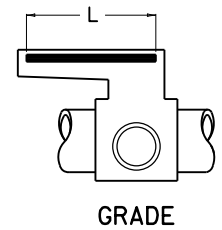

~ NOTES ~

- SEE CUR. STD. DWG. RDB-273 FOR LID REINFORCEMENT.
- e, f, AND g BARS SPACED 1'-0" O.C. ALL OTHER BARS SPACED 6" O.C. EXCEPT WHERE OTHERWISE SPECIFIED.
- PLACE ALL STEEL REINFORCEMENT 2" FROM INSIDE OF INLET WALL EXCEPT WHERE OTHERWISE SPECIFIED.

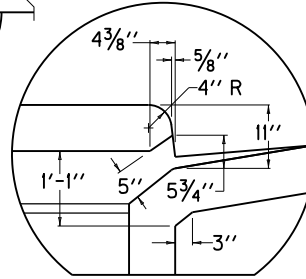

BARRIER CURB

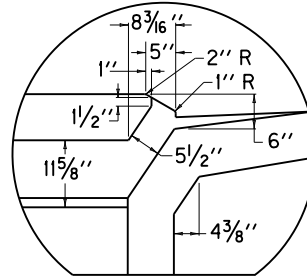

ISLAND CURB

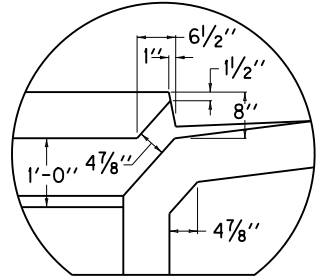

STANDARD CURB

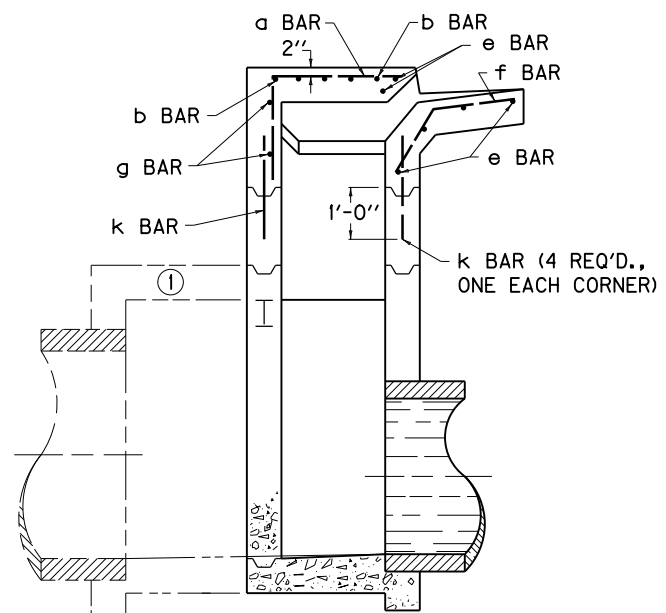

SECTION B-B

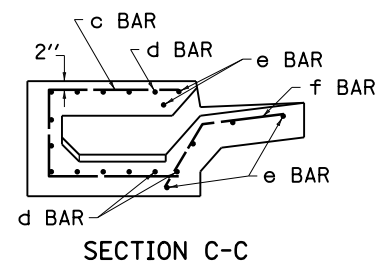

USE WITH CUR. STD. DWGS.
RDB-270, RDB-272, RDB-273,
RDB-400, RDB-410, RDB-420

KENTUCKY	
DEPARTMENT OF HIGHWAYS	
CURB BOX INLET	
TYPE A	
(STEEL DRAWING)	
STANDARD DRAWING NO. RDB-271-05	
SUBMITTED	DATE 12-01-15
<small>DIRECTOR, DIVISION OF DESIGN</small>	
APPROVED	DATE 12-01-15
<small>STATE HIGHWAY ENGINEER</small>	