

PLAN VIEW

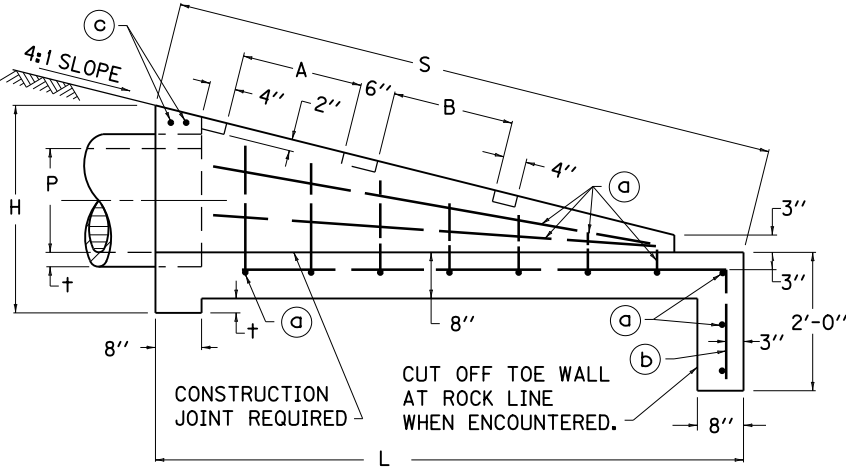

ELEVATION VIEW

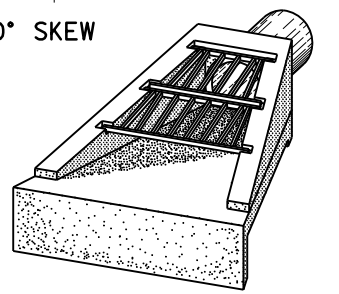
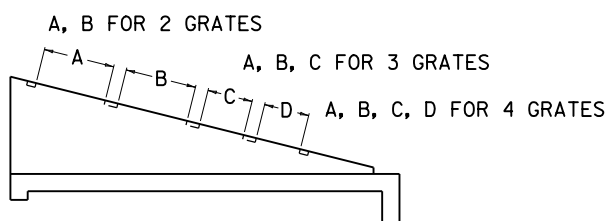
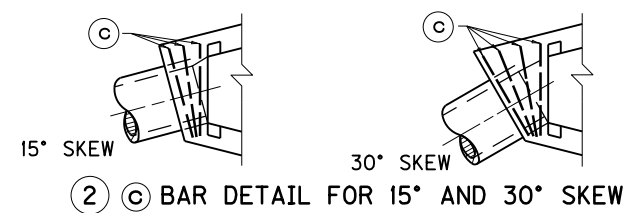
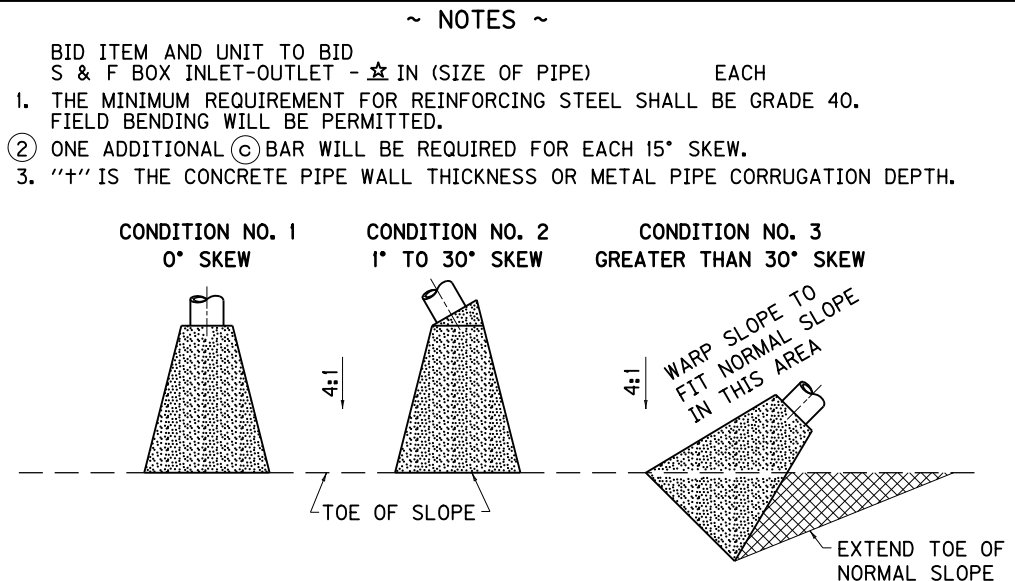

PICTORIAL VIEW OF 18" OR 24" STRUCTURE

| DIMENSIONS | | | | | | | | | | |
|------------|-------|---------|------------|----------|---------|--------|-------|-------|-------|-------|
| P | H | L | S | R | V | W | A | B | C | D |
| 18" | 3'-0" | 8'-6" | 8'-9/8" | 2'-11/2" | 3'-7/2" | 7'-3" | 1'-9" | 1'-9" | ----- | ----- |
| 24" | 3'-7" | 10'-8" | 11'-0" | 3'-6/2" | 4'-5/2" | 8'-11" | 2'-9" | 2'-9" | ----- | ----- |
| 30" | 4'-2" | 12'-10" | 13'-2 3/4" | 4'-1/2" | 5'-3/2" | 10'-7" | 2'-9" | 2'-9" | 1'-9" | ----- |
| 36" | 4'-9" | 15'-0" | 15'-5/2" | 4'-8/2" | 6'-1/2" | 12'-3" | 2'-9" | 2'-9" | 1'-9" | 1'-9" |

| NO. OF GRATES REQ'D. | |
|----------------------|----|
| 2' | 3' |
| 2 | -- |
| -- | 2 |
| 1 | 2 |
| 2 | 2 |

| NO. 4 REINFORCEMENT BARS | | | | | CLASS A CONC. |
|----------------------------|------------|------------|-----|------|---------------|
| NUMBER - LENGTH AND WEIGHT | | | | | |
| (a) | (b) | (3) | (c) | LBS. | CU. YDS. |
| 14 @ 6'-5" | 3 @ 8'-6" | 2 @ 2'-8" | | 81 | 1.8 |
| 16 @ 8'-0" | 3 @ 10'-6" | 2 @ 3'-3" | | 111 | 2.7 |
| | 3 @ 12'-9" | 2 @ 3'-10" | | 146 | 3.8 |
| 20 @ 11'-4" | 3 @ 15'-0" | 2 @ 4'-5" | | 187 | 5.1 |

USE WITH CUR. STD. DWG. RDB-106

KENTUCKY
DEPARTMENT OF HIGHWAYS

SLOPED AND FLARED BOX INLET - OUTLET
18" - 24" - 30" - 36"
ALL SKEWS

STANDARD DRAWING NO. RDB-105-06

SUBMITTED: *William P. Gullett* DATE: 12-01-15
DIRECTOR, DIVISION OF DESIGN

APPROVED: *[Signature]* DATE: 12-01-15
STATE HIGHWAY ENGINEER