

PLAN VIEW

4 - 7/8" DIA. x 1'-6" MIN. ANCHOR BOLTS
 ---OR---
 THREADED RODS (HEX NUTS AND FLAT WASHERS)

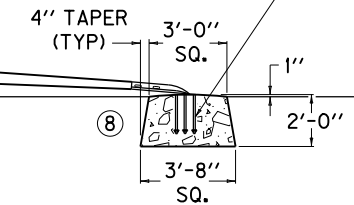

ELEVATION VIEW

~ NOTES ~

- BID ITEM AND UNIT TO BID
 GUARDRAIL END TREATMENT TYPE 7 EACH
- GUARDRAIL END TREATMENT TYPE 7 SHALL BE TO THE PAY LIMITS AS DETAILED AND THE CONTRACT UNIT PRICE EACH SHALL INCLUDE TERMINAL SECTION NO. 2, STEEL "W" BEAM GUARDRAIL (SINGLE FACE), GUARDRAIL POSTS MI, CONCRETE ANCHOR BLOCK, EXCAVATION, LABOR, HARDWARE AND INCIDENTALS NECESSARY FOR THE INSTALLATION.
 - SPLICE BOLTS AT TERMINAL SECTION NO. 2 SHALL BE LOOSELY TIGHTENED AND CENTERED TO ALLOW MAXIMUM MOVEMENT DUE TO EXPANSION. ONE (1) 1/16" ROUND WASHER AND ONE (1) RECTANGULAR PLATE WASHER REQUIRED FOR EACH SPLICE BOLT, AT TERMINAL SECTION NO. 2.
 - THE CONCRETE ANCHOR BLOCK MAY BE PRECAST OR CAST-IN-PLACE. WHEN THE CONCRETE ANCHOR BLOCK IS CAST-IN-PLACE FORMING OF THE SIDES SHALL BE REQUIRED.
 - THE DESIREABLE OFFSET DISTANCE FROM THE NORMAL GUARDRAIL LINE SHALL BE 4'-0". THE MINIMUM OFFSET DISTANCE FROM THE NORMAL GUARDRAIL LINE IS ZERO FEET.
 - SEE CUR. STD. DWG. [RBR-001](#), [RBR-005](#), [RBR-010](#), AND [RBR-015](#) FOR APPLICABLE DETAILS AND SPECIFICATIONS.
 - APPROX. QUANTITY FOR ANCHOR BLOCK: 0.83 CU. YD. CLASS "A" CONCRETE FOR TYPE 7 INSTALLATION.
 - THIS GUARDRAIL END TREATMENT IS NOT FOR USE ON APPROACH END ON HIGH SPEED NHS ROUTES ABOVE 35 MPH.
 - SEE CUR. STD. DWG. [RBR-051](#) FOR ALTERNATE END ANCHOR.

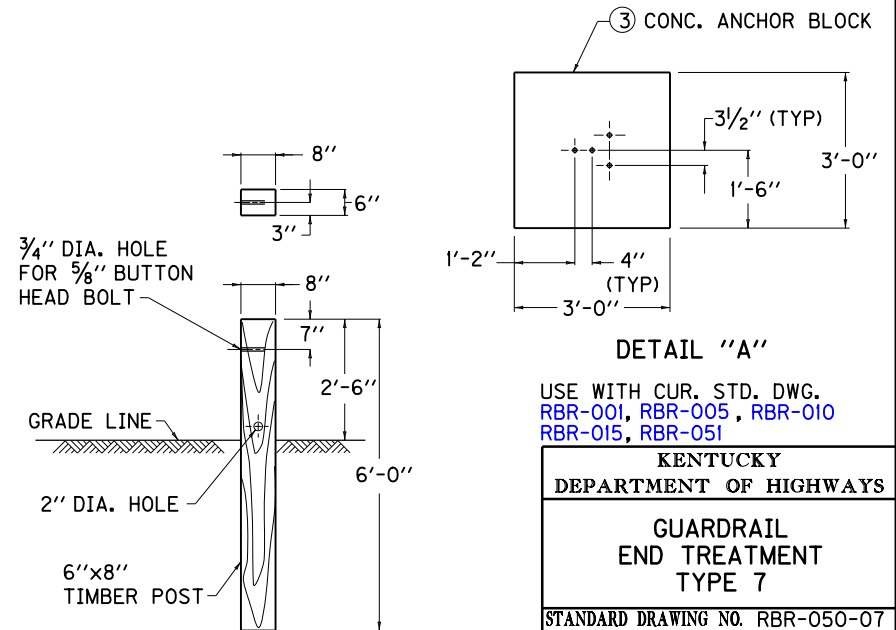

MI POST DETAIL

USE WITH CUR. STD. DWG.
[RBR-001](#), [RBR-005](#), [RBR-010](#)
[RBR-015](#), [RBR-051](#)

KENTUCKY DEPARTMENT OF HIGHWAYS	
GUARDRAIL END TREATMENT TYPE 7	
STANDARD DRAWING NO. RBR-050-07	
SUBMITTED <i>William P. Galt</i>	DATE 12-01-15
<small>DIRECTOR, DIVISION OF DESIGN</small>	
APPROVED <i>[Signature]</i>	DATE 12-01-15
<small>STATE HIGHWAY ENGINEER</small>	