

PLAN VIEW

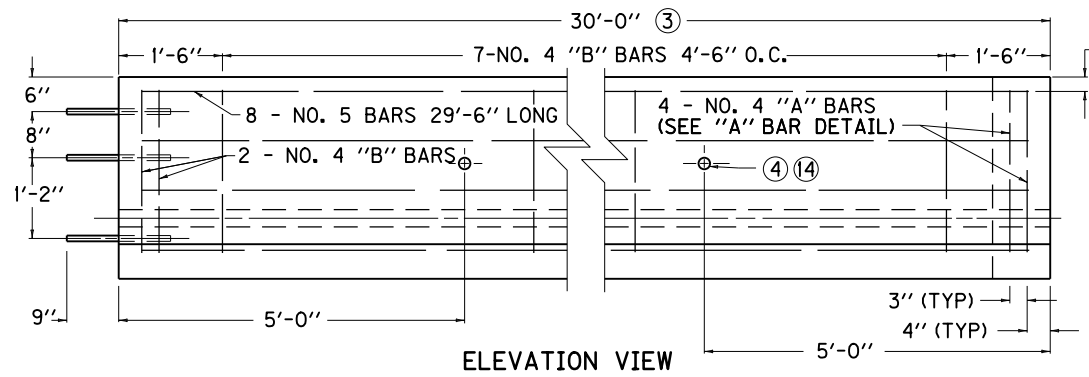

ELEVATION VIEW

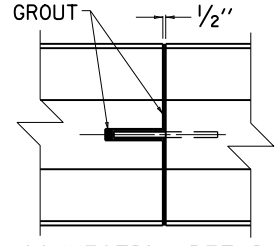

CONNECTION DETAIL

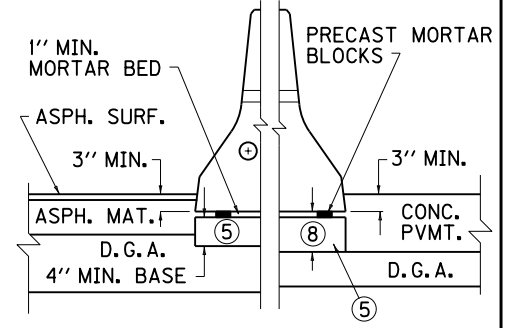

PAVEMENT DETAIL ⑦
(SEE RIGHT ELEVATION FOR DIMENSIONS)

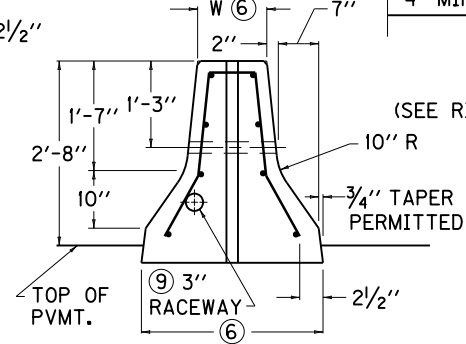

RIGHT ELEVATION VIEW

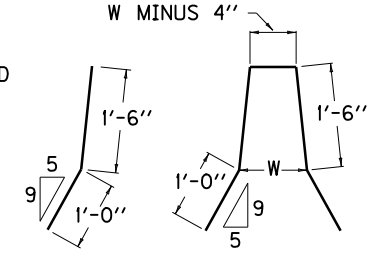

DETAIL OF "A" BAR
DETAIL OF "B" BAR

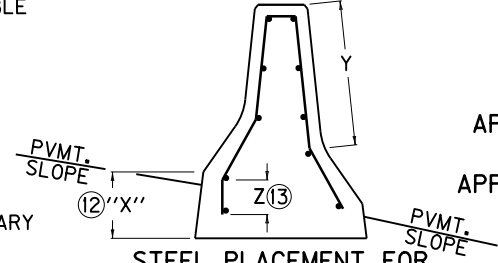

STEEL PLACEMENT FOR ASYMMETRICAL WALL SECTION

APPROX. REINF. /30' SECTION
289 LBS.

APPROX. CU. YD. CONC. /LIN. FT.

9" WIDE TOP	= 0.16
12" WIDE TOP	= 0.18
14" WIDE TOP	= 0.20

APPROX. WEIGHT /30' SECTION
BASED ON 150 LBS./CU. FT

9" WIDE TOP	= 9.8 TONS
12" WIDE TOP	= 11.1 TONS
14" WIDE TOP	= 12.1 TONS

FOR ILLUSTRATION PURPOSES, THE PAVEMENT DETAIL (RIGHT) DEPICTS THE INSTALLATION OF A CONCRETE MEDIAN BARRIER (PRECAST) WITH NEW RIGID PAVEMENT ON ONE SIDE AND NEW FLEXIBLE PAVEMENT ON THE OPPOSITE SIDE (SEE PLANS FOR APPLICABLE PAVEMENT DESIGN).

~ NOTES ~

- BID ITEM AND UNIT TO BID:
 CONCRETE MEDIAN BARRIER TYPE ⊕ ⊕ LF
- ⊕ 9 OR 12 OR 14 DEPENDING ON "W".
 ⊕ A OR C DEPENDING ON PAVEMENT TYPE (SEE CUR. STD. DWG. RBM-001 FOR TYPE).
- WITH FLEXIBLE PAVEMENT THE CONTRACT UNIT PRICE PER LINEAR FOOT SHALL INCLUDE THE BASE, ALL CONCRETE, LABOR, REINFORCING STEEL AND ALL OTHER INCIDENTALS NECESSARY TO COMPLETE THE PERMANENT INSTALLATION.
 - WITH RIGID PAVEMENT THE CONTRACT UNIT PRICE PER LINEAR FOOT SHALL INCLUDE, THE BASE, ALL CONCRETE, LABOR, REINFORCING STEEL AND ALL OTHER INCIDENTALS NECESSARY TO COMPLETE THE PERMANENT INSTALLATION.
 - SHORTER SECTIONS MAY BE PERMITTED IF APPROVED IN WRITING BY THE ENGINEER.
 - 2" DIA. LIFTING HOLE - 2 REQUIRED AT EACH SECTION. FORMED WITH 2" P.V.C. PIPE OR EQUAL.
 - SEE ELSEWHERE IN THE PLANS FOR BASE REQUIREMENTS.
 - 9" WIDE TOP WITH 2'-3" WIDE BASE, OR 12" WIDE TOP WITH 2'-6" WIDE BASE OR 14" WIDE TOP 2'-8" WIDE BASE. (TAPER NOT INCLUDED IN BASE WIDTH).
 - OTHER METHODS OF ANCHORAGE WILL BE ACCEPTABLE IF APPROVED IN WRITING BY THE ENGINEER.
 - PAVEMENT THICKNESS MINUS 3".
 - THE RACEWAY SHALL BE TIED TO EACH OF THE "A" AND "B" BARS TO PREVENT SAG. SEE ELSEWHERE IN THE PLANS FOR SIZE, LOCATION, AND PAYMENT FOR RACEWAY WHEN REQUIRED.
 - PLACE ALL STEEL REINFORCEMENT A CLEAR DISTANCE OF 2" MIN. FROM OUTSIDE FACE OF WALL, EXCEPT WHERE SHOWN OTHERWISE.
 - SHOP DRAWINGS SHALL BE APPROVED PRIOR TO MANUFACTURE.
 - WHEN THE "X" DIMENSION EQUALS 10" THE BAR SHALL BE TURNED DOWN 6" ("Z" DIMENSION) AND AN ADDITIONAL LONGITUDINAL BAR SHALL BE ADDED AT THE BOTTOM OF THE TURN DOWN ("Z" DIMENSION) AND TO THE "Y" PORTION OF THE BAR. FOR EACH 6" INCREMENT OF THE "X" DIMENSION ABOVE 10", AN ADDITIONAL LONGITUDINAL BAR SHALL BE ADDED IN THE "Z" AND "Y" PORTION OF THE BAR.
 - THE "Z" DIMENSION SHALL INCREASE INCH FOR INCH WHEN THE "X" DIMENSION EXCEEDS 10".
 - LIFTING BARS SHALL BE REQUIRED TO PREVENT SPALLING OF CONCRETE AROUND HOLES.
 - WHEN THE PRECAST WALL IS USED IN PERMANENT CONSTRUCTION THE LIFTING HOLES SHALL BE FILLED WITH GROUT.

USE WITH CUR. STD. DWG.
 RBM-001

KENTUCKY	
DEPARTMENT OF HIGHWAYS	
CONCRETE MEDIAN BARRIER PRECAST (PERMANENT - NEW PAVEMENT)	
STANDARD DRAWING NO. RBM-003-11	
SUBMITTED <i>William P. Gullett</i>	12-01-15
<small>DESIGNED BY</small>	
APPROVED <i>[Signature]</i>	DATE 12-01-15
<small>STATE HIGHWAY ENGINEER</small>	
<small>DATE</small>	