

TYPICAL GUARDRAIL INSTALLATIONS FOR OVERHEAD SIGN SUPPORT - TRUSS (RAISED MEDIAN)

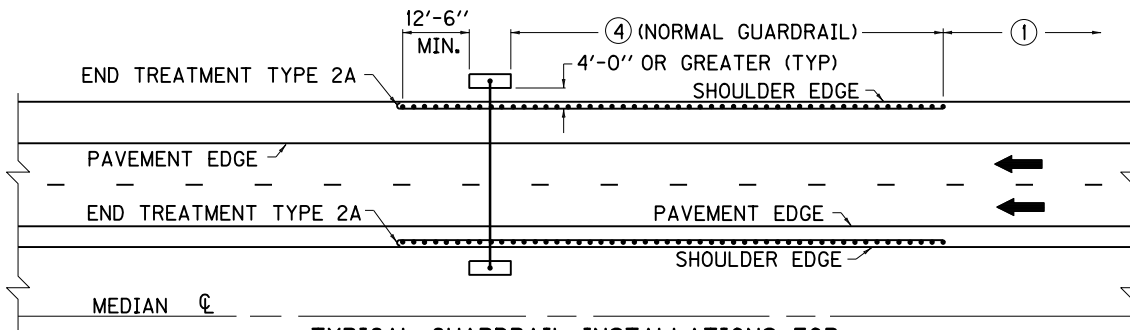

TYPICAL GUARDRAIL INSTALLATIONS FOR OVERHEAD SIGN SUPPORT - TRUSS (DEPRESSED MEDIAN)

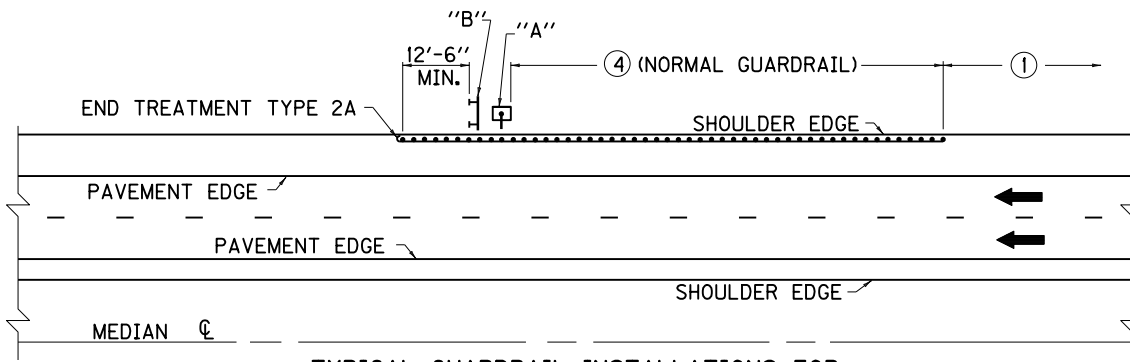

TYPICAL GUARDRAIL INSTALLATIONS FOR "A" CANTILEVER SIGN SUPPORT OR "B" OVERHEAD SIGN SUPPORT

~ NOTES ~

- ① TO TERMINATE GUARDRAIL INSTALLATION:
 - A. ALL FILLS, ALSO SOLID ROCK CUTS WITH ADEQUATE VEHICLE RECOVERY ZONE BEHIND GUARDRAIL; USE END TREATMENT TYPE 1 OR 4A.
 - B. SOLID ROCK CUTS WITHOUT ADEQUATE VEHICLE RECOVERY ZONE BEHIND GUARDRAIL; USE END TREATMENT TYPE 2A.
 - C. EARTH CUTS AND SOFT ROCK CUTS; USE END TREATMENT TYPE 3.
2. IF GAPS OF 200 FEET OR LESS SHOULD OCCUR BETWEEN SECTIONS OF GUARDRAIL, THE GUARDRAIL SHALL BE EXTENDED THROUGH SUCH GAPS TO PROVIDE A CONTINUOUS SECTION.
3. GUARDRAIL INSTALLATION IS NOT NECESSARY FOR SIGNS MOUNTED ON:
 - A. CHANNEL POST IN TYPE "B" OR "C" BASES.
 - B. TYPE "B" BREAKAWAY BEAMS.
 - C. SIGNS MOUNTED IN CAST ALUMINUM SHOES. (SEE SIGN PLAN).
- ④ THE MIN. LENGTH OF GUARDRAIL, INCLUDING THE END TREATMENT, PRECEDING A FIXED OBJECT IS 200 FEET (LENGTH MAY BE REDUCED SHOULD FIELD CONDITIONS WARRANT).
- ⑤ WHEN CONCRETE BARRIER WALL IS REQUIRED SEE CUR. STD. DWG. [RBM-015](#) FOR APPLICABLE DETAILS.

USE WITH CUR. STD. DWG.
[RBM-015](#)

| | |
|--|----------|
| KENTUCKY DEPARTMENT OF HIGHWAYS | |
| GUARDRAIL INSTALLATION AT SIGN SUPPORTS | |
| STANDARD DRAWING NO. RBI-006-07 | |
| SUBMITTED <i>William S. Gullett</i> | 12-01-15 |
| <small>DIRECTOR, DIVISION OF DESIGN</small> | |
| APPROVED <i>[Signature]</i> | 12-01-15 |
| <small>STATE HIGHWAY ENGINEER</small> | |
| <small>DATE</small> | |