

- ~ NOTES ~**
- GUARDRAIL CONNECTOR TO CONCRETE MEDIAN BARRIER END SHALL BE PAID FOR AT THE CONTRACT UNIT PRICE EACH AND INCLUDES TERMINAL SECTION NO. 2, ADDITIONAL POSTS, ADDITIONAL OFFSET BLOCKS, ADDITIONAL RAIL ELEMENTS, HARDWARE, ETC., AND OTHER INCIDENTALS AS SHOWN BETWEEN POINTS A and B NECESSARY TO COMPLETE THE INSTALLATION AS DETAILED.
 - THE STEEL "W" BEAM GUARDRAIL (DOUBLE FACE), IS A SEPARATE BID ITEM AND SHALL BEGIN PAYMENT AT POINT A.
 - THE 4-BOLT INSERT ASSEMBLY INSTALLATION SHALL BE INCIDENTAL TO THE COST OF THE BRIDGE SUPERSTRUCTURE CONCRETE OR CONCRETE MEDIAN BARRIER END AS APPLICABLE.
 - 4-BOLT ASSEMBLIES:
 - THE $\frac{7}{8}$ " x 2" CAP SCREWS WITH STANDARD STEEL WASHERS SHALL BE GALVANIZED AND CONFORM TO ASTM A-325.
 - NO. W-8 GAGE WIRE, COLD DRAWN CONFORMING TO ASTM A-82.
 - STEEL INSERTS SHALL CONFORM TO ASTM A-108 GRADES C1008 AND C1010 OR B1113.
 - SEE CUR. STD. DWGS. IN THE **RBI**, **RBE**, AND **RBR-SERIES** AS APPLICABLE.
 - SEE BRIDGE PLANS FOR CONSTRUCTION DETAILS WHEN APPLICABLE.
- GUARDRAIL CONNECTOR TO CONCRETE MEDIAN BARRIER END EACH LF
 GUARDRAIL-STEEL W BEAM-D FACE LF

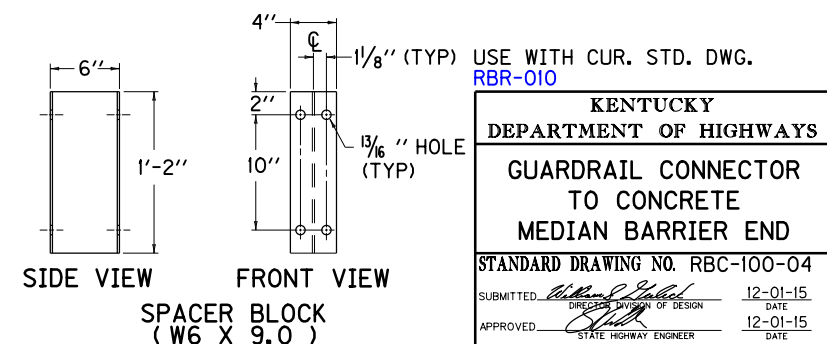
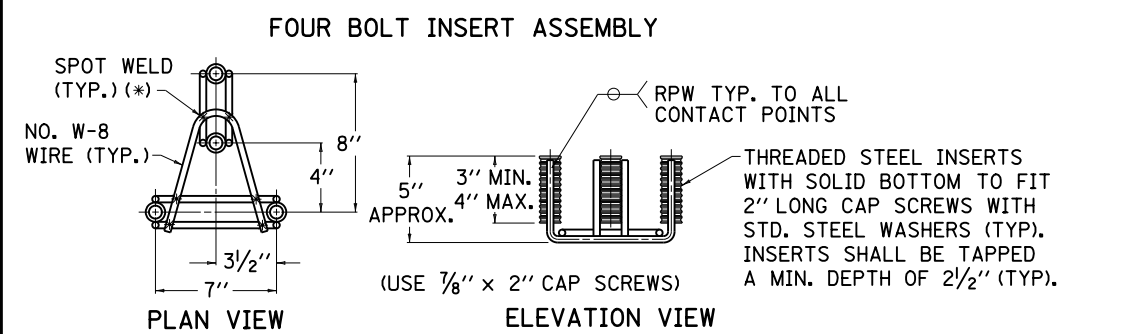

KENTUCKY DEPARTMENT OF HIGHWAYS		
GUARDRAIL CONNECTOR TO CONCRETE MEDIAN BARRIER END		
STANDARD DRAWING NO. RBC-100-04		
SUBMITTED	<i>William P. Hall</i>	12-01-15
DIRECTOR, DIVISION OF DESIGN		DATE
APPROVED	<i>[Signature]</i>	12-01-15
STATE HIGHWAY ENGINEER		DATE