

NOTE:
Bevel flanges and web of pile extension on 1:1 bevel as shown and employ conventional butt weld.

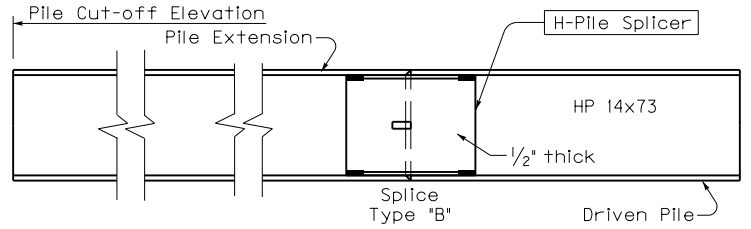
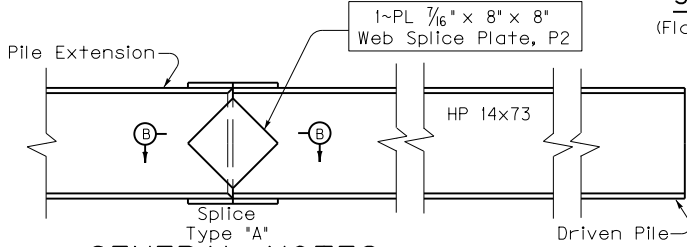
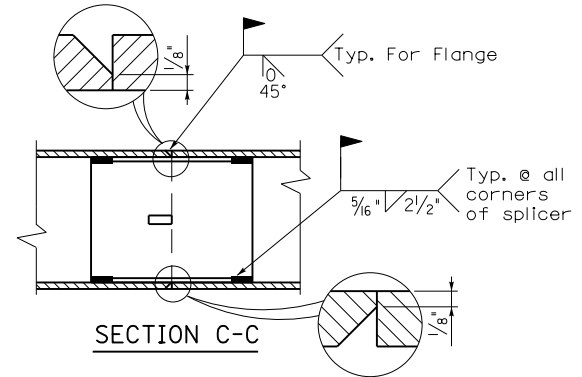
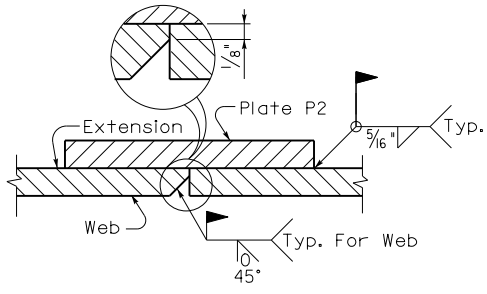

GENERAL NOTES

SPECIFICATIONS: Kentucky Department of Highways Standard Specifications for Road and Bridge Construction, current edition.

MATERIALS: Ensure structural steel piles conform to A.S.T.M. A709 Grade 50, current Specifications.

SPLICE PLATES: Ensure all pile splicing options conform to A.S.T.M. A709 Grade 50, current Specifications. In lieu of Splice Option 'A' or Splice option 'B', splice plates may be flame cut from HP14x73 sections. If flange sections are used, the portion cut at the web must be turned outside in order to obtain a tight fit. Grind the edges smooth prior to welding.

SPLICE OPTION 'B': The pile splicer shown in the details for Splice Option 'B' may be Champion H-Pile Splicer, Model HP 30000, or an approved equal. Ensure the splicer is in accordance to the manufacturer's recommendations and subject to the Engineer's approval.

FIELD WELDS: Ensure field welding material and workmanship for all piling conforms to the current Joint Specifications ANSI/AASHTO/AWS D1.5 Bridge Welding Code. Splice piles as indicated above only when driven below cut-off elevation.

PAYMENT: Payment for the piles in accordance with plans and specifications will be made at the contract price per linear foot.

PAINT: No painting is required on steel piles.

MILL TEST REPORTS: Furnish mill test reports in triplicate to the Department showing that all materials furnished conform to the Specifications.

KENTUCKY DEPARTMENT OF HIGHWAYS	
HP14x73 STEEL PILE	
STANDARD DRAWING NO. BPS-009-08	
SUBMITTED <i>Mark Wite</i>	12-01-11 DATE
<small>DIRECTOR DIVISION OF STRUCTURAL DESIGN</small>	
APPROVED <i>[Signature]</i>	12-01-11 DATE
<small>STATE HIGHWAY ENGINEER</small>	