

PLAN VIEW

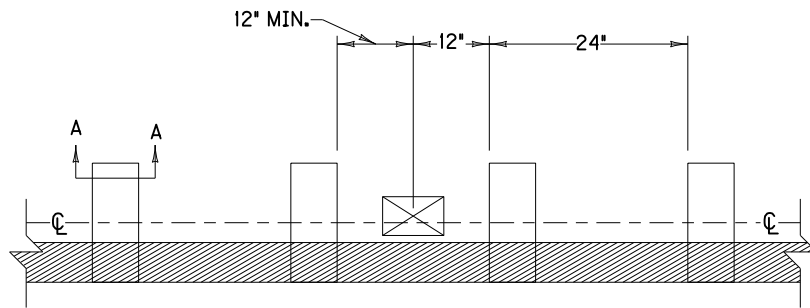

DETAIL "A"

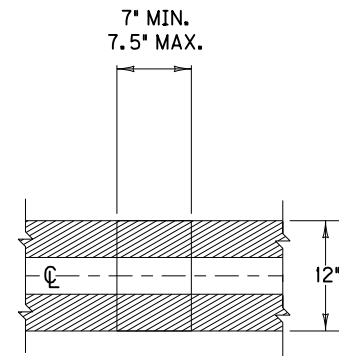

RUMBLE STRIP DETAIL

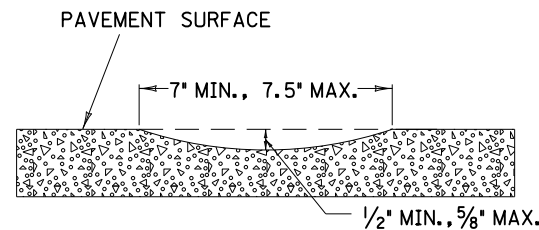

SECTION A-A

**GENERAL NOTES**

1. DISTANCES SHOWN ARE APPROXIMATE. MAINTAIN RUMBLE STRIP DIMENSIONS AND SPACING AS MUCH AS POSSIBLE.
2. RUMBLE STRIPS SHALL BE INSTALLED IN LINE WITH THE CENTER OF THE ROADWAY AS MUCH AS POSSIBLE.
3. DISCONTINUE RUMBLE STRIPS AT LEAST 12" BEFORE AND AFTER THE CENTER OF EACH RAISED PAVEMENT MARKER. INSTALL AS MANY RUMBLE STRIPS AS POSSIBLE BETWEEN ADJACENT PAVEMENT MARKERS WHILE MAINTAINING THE 24" CYCLE.
4. DO NOT INSTALL CENTERLINE RUMBLE STRIPS IN AREAS INDICATED ON STANDARD DRAWING TPM-150.
5. RUMBLE STRIPS SHALL BE OMITTED WHERE THE POSTED SPEED LIMIT IS 45 MPH OR LESS.

DRAWING NOT TO SCALE

USE WITH CUR. STD. DWG.  
TPM-150

KENTUCKY  
DEPARTMENT OF HIGHWAYS

CENTERLINE  
RUMBLE STRIPS  
4 INCH STRIPING

STANDARD DRAWING NO. TPM-155-01  
 SUBMITTED BY: *B. Allen Wolfe* DATE: 12-2-11  
 DIRECTOR OF TRAFFIC OPERATIONS  
 APPROVED: *[Signature]* DATE: 12-2-11  
 STATE HIGHWAY ENGINEER