

~ PLAN VIEW ~

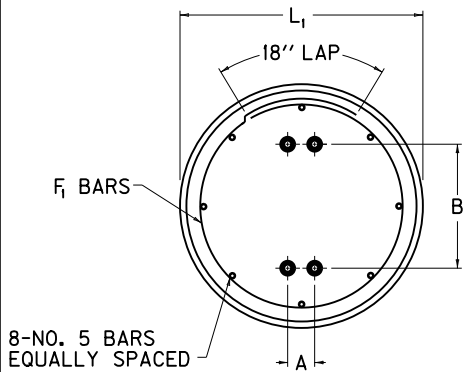

~ TOP VIEW ~

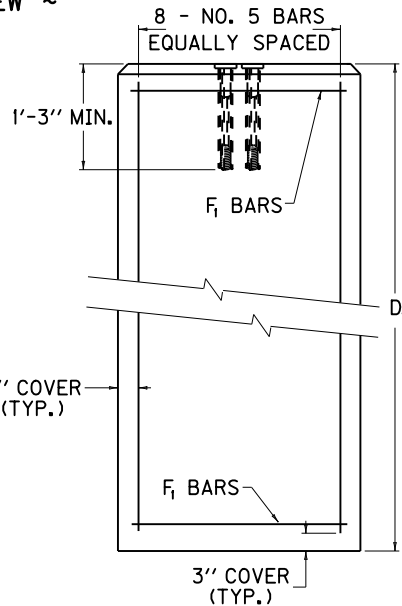

~ SIDE VIEW ~

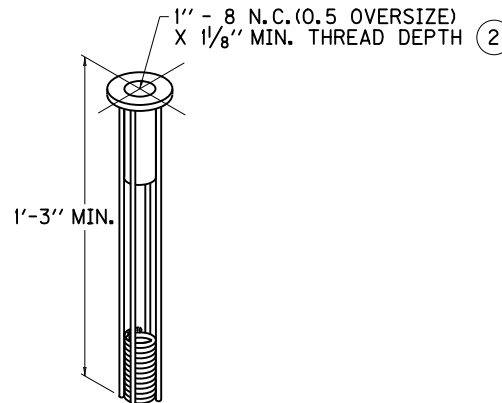

~ ANCHOR PICTORIAL VIEW ~

FOOTING SELECTION TABLE

POST SIZE	L ₁ DIA.	D ₁ DEPTH	STEEL F ₁ BARS		REINF. LBS.	CONC. CU. YD.
			QTY	SIZE		
W6	2'-0"	5'-0"	5	#4	57	0.58
W8	2'-6"	7'-0"	7	#4	88	1.27
W10	3'-0"	8'-0"	8	#4	110	2.09
W12	3'-0"	8'-0"	8	#4	110	2.09
W14	3'-0"	9'-0"	9	#4	124	2.36
W16	3'-6"	9'-0"	9	#4	133	3.21
W18	3'-6"	9'-0"	9	#4	133	3.21
W21	4'-0"	9'-0"	9	#4	143	4.19

~NOTES~

- ENTER FOOTING SELECTION TABLE WITH REQUIRED POST SIZE AND FIND REQUIRED FOOTING VALUES AS SHOWN IN DETAILS.
- THE ANCHOR SHALL BE 304 STAINLESS STEEL WITH 1053 STEEL ROD AND COIL.
- FORM TOP 1'-0" OF THE FOOTING.
- USE CLASS "A" CONCRETE IN ALL FOOTINGS.
- ACTUAL DIMENSIONS "A" & "B" SHOULD BE OBTAINED FROM THE MANUFACTURER OR MEASURED FROM THE ASSEMBLED BRACKETS PRIOR TO PLACEMENT OF ANCHORS.
- TO INSURE PROPER SPACING AND ALIGNMENT OF ANCHORS, IT IS RECOMMENDED THAT ALL ANCHORS BE HELD IN PLACE BY A RIGID TEMPLATE WHILE THE CONCRETE IS PLACED AND CURED.
- FOOTING PROJECTIONS ABOVE GROUND LINE SHALL BE MINIMIZED. THE MAXIMUM PERMISSIBLE FOOTING PROJECTION SHALL BE 4" ON THE LOWER SLOPE SIDE. WHERE NECESSARY, THE SHADED AREA OF THE FOOTING SHALL BE REMOVED AND REINFORCEMENT SHALL BE BENT TO FIT.
- THE TOP OF THE FOOTING SHALL NOT PROJECT MORE THAN 4" ABOVE ANY 5'-0" CHORD ALIGNED PERPENDICULAR TO THE EDGE OF THE ROADWAY BETWEEN A POINT ON THE GROUND SURFACE ON ONE SIDE OF THE SUPPORT TO A POINT ON THE GROUND SURFACE ON THE OTHER SIDE OF THE SUPPORT.

KENTUCKY DEPARTMENT OF HIGHWAYS		
FOOTING DETAILS FOR TYPE C BEAM		
STANDARD DRAWING NO. RCX-061		
SUBMITTED: <i>David Kott</i>	DIRECTOR DIVISION OF DESIGN	11-21-07 DATE
APPROVED: <i>November M. [Signature]</i>	STATE HIGHWAY ENGINEER	11-21-07 DATE