

DETAIL FOR LONGITUDINAL UNDERDRAINS

DETAIL FOR TRANSVERSE UNDERDRAIN CUT TO FILL CONDITION

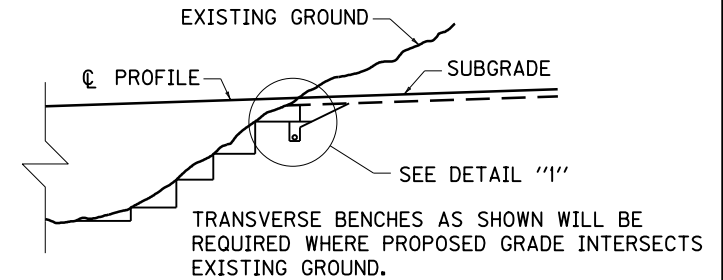
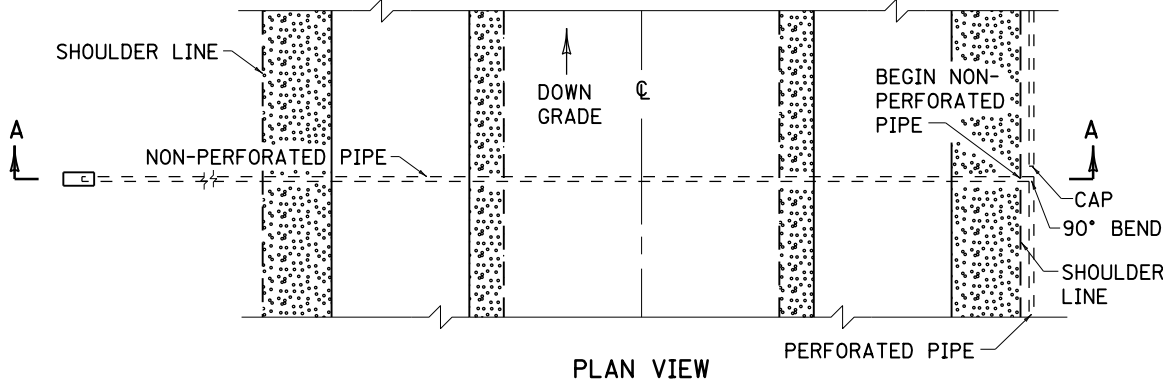

THE EXCAVATION NECESSARY TO FORM THE BENCHES SHALL BE PAID FOR AT THE CONTRACT UNIT PRICE BID FOR ROADWAY EXCAVATION.

UNDERDRAINS WILL BE REQUIRED ON UPGRADE BENCH. THIS PERFORATED PIPE UNDERDRAIN SHOULD BE PLACED IN ROCK OR SHALE FORMATIONS IF POSSIBLE. PLAN LOCATIONS ARE FOR ESTIMATING PURPOSES ONLY. EXACT LOCATIONS TO BE DETERMINED BY THE ENGINEER ON CONSTRUCTION. THE FOOTAGE THUS INSTALLED SHALL BE PAID FOR AT THE CONTRACT UNIT PRICE PER LINEAR FOOT FOR PERFORATED PIPE WHICH SHALL CONSTITUTE FULL COMPENSATION FOR FURNISHING AND INSTALLING PIPE INCLUDING ALL CONNECTIONS, FITTINGS, FURNISHING AND PLACING AGGREGATE, PLACING BACKFILL, AND FURNISHING ALL LABOR AND TOOLS NECESSARY TO COMPLETE THE WORK.

EXCAVATION FOR BOTH THE PERFORATED AND NON-PERFORATED PIPE SHALL BE MEASURED AND PAID FOR AT THE UNIT PRICE AS SET FORTH IN THE STANDARD SPECIFICATIONS.

BENCHING SHALL BE REQUIRED AT ALL TRANSITIONS FROM ROCK CUTS TO FILL WHETHER OR NOT UNDERDRAIN IS REQUIRED.

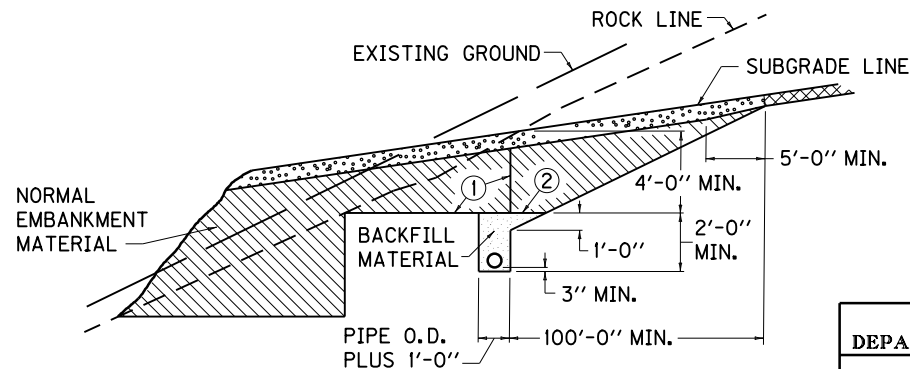
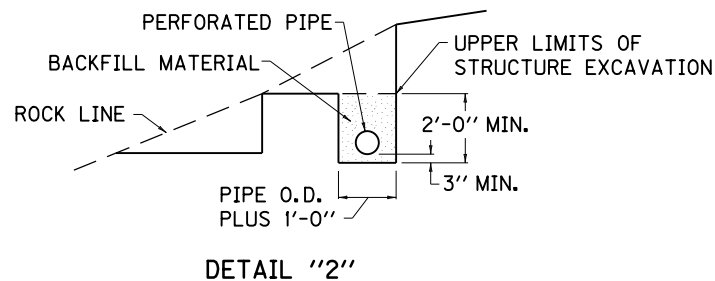
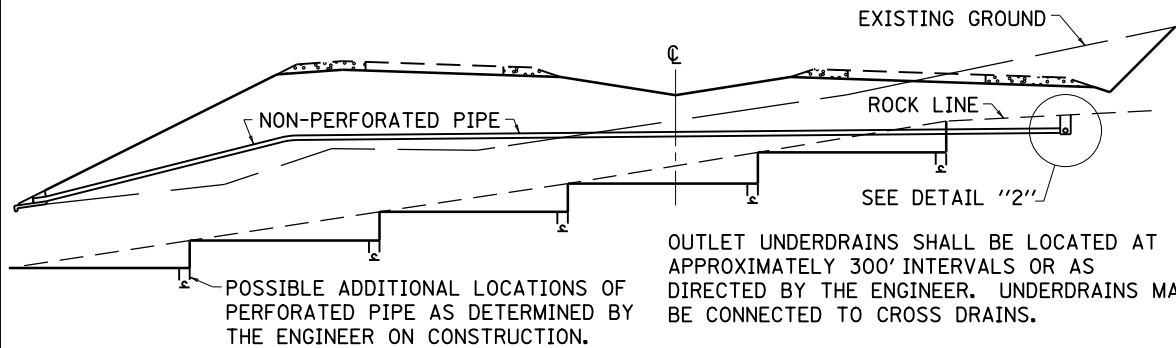

NOTES

- ① LIMITS OF FIRST BENCH.
 - ② UPPER LIMITS OF STRUCTURE EXCAVATION.
- ALL PERFORATED PIPE SHALL COMPLY WITH THE STANDARD SPECIFICATIONS.
ALL NON-PERFORATED PIPE SHALL BE THE SAME TYPE AS THE PERFORATED PIPE, EXCEPT WITHOUT PERFORATIONS.

KENTUCKY DEPARTMENT OF HIGHWAYS		
PERFORATED PIPE UNDERDRAINS		
STANDARD DRAWING NO. RDP-006-03		
SUBMITTED: <i>David Kott</i>	DIRECTOR DIVISION OF DESIGN	11-21-07 DATE
APPROVED: <i>November Mathews</i>	STATE HIGHWAY ENGINEER	11-21-07 DATE