

PLAN VIEW

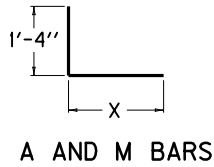

A AND M BARS

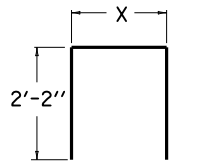

B AND F BARS

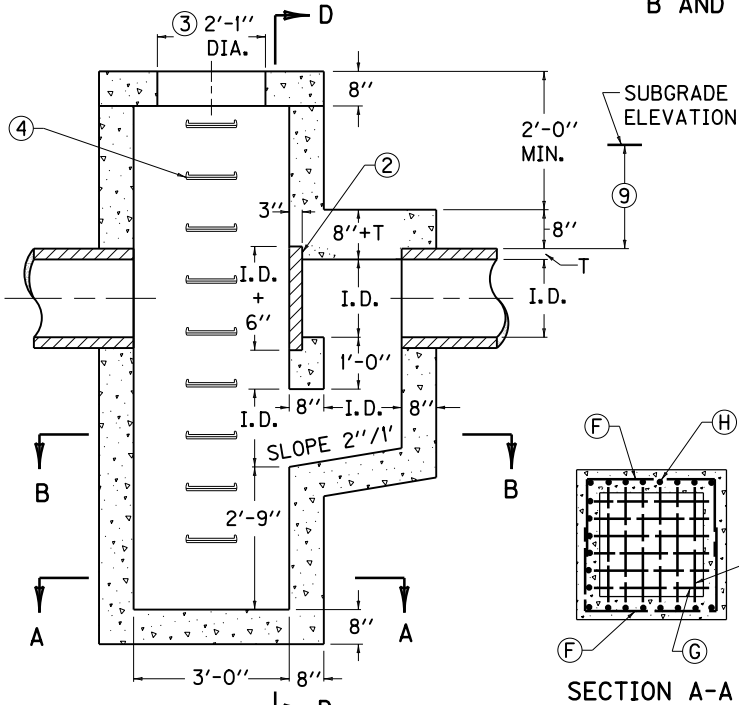

SECTION C-C

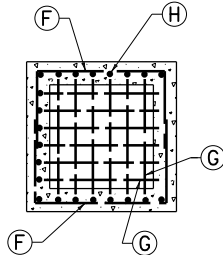

SECTION A-A

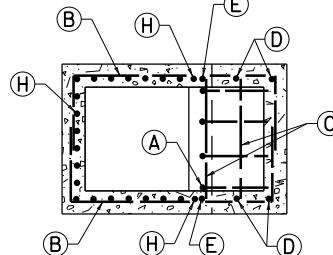

SECTION B-B

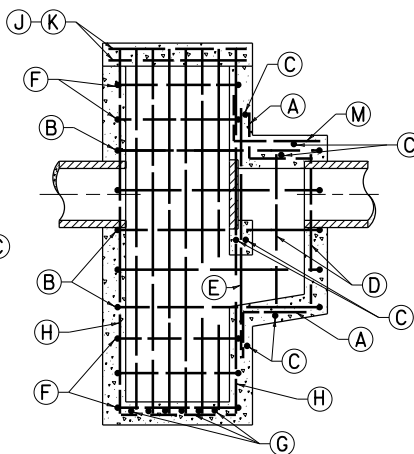

SECTION C-C

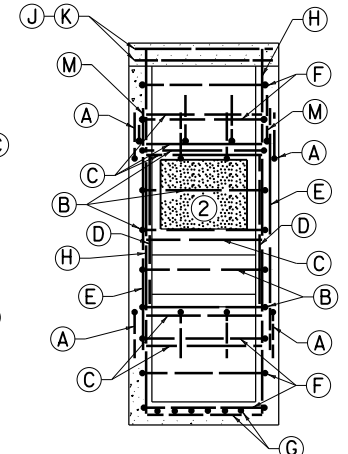

SECTION D-D

⑩ BILL OF REINFORCEMENT (NO. 5 BARS)

PIPE NO. 5 BARS	15"			18"			21"			24"				
	QTY.	TOTAL LG.	X DIM.	QTY.	TOTAL LG.	X DIM.	QTY.	TOTAL LG.	X DIM.	QTY.	TOTAL LG.	X DIM.		
(A)	8	2'-11"	1'-7"	8	3'-2"	1'-10"	8	3'-5"	2'-1"	8	3'-8"	2'-4"		
(B)	10	9'-6"	5'-3"	10	9'-9"	5'-6"	12	10'-0"	5'-9"	12	10'-4"	6'-0"		
(C)	7	3'-4"	-	7	3'-4"	-	7	3'-4"	-	9	3'-4"	-		
(D)	4	3'-11"	-	4	4'-4"	-	4	4'-10"	-	6	5'-4"	-		
(E)	2	6'-6"	-	2	7'-0"	-	2	7'-6"	-	2	8'-0"	-		
(F)	10	7'-7"	3'-4"	10	7'-7"	3'-4"	10	7'-7"	3'-4"	10	7'-7"	3'-4"		
(G)	12	3'-4"	-	12	3'-4"	-	12	3'-4"	-	12	3'-4"	-		
(H)	22	9'-1"	-	22	9'-8"	-	22	10'-2"	-	22	10'-8"	-		
(J)	8	3'-4"	-	8	3'-4"	-	8	3'-4"	-	8	3'-4"	-		
(K)	8	2'-4"	-	8	2'-4"	-	8	2'-4"	-	8	2'-4"	-		
(M)	4	3'-7"	2'-3"	4	3'-10"	2'-6"	4	4'-1"	2'-9"	4	4'-4"	3'-0"		
			569 LBS.			591 LBS.			632 LBS.			672 LBS.		

CU. YDS. CLASS "A" CONC.

4.73	5.07	5.43	5.79
0.36 ①			

NOTES

- ① CU. YD. PER FOOT INCREASE OR DECREASE WHEN MANHOLE HEIGHT VARIES FROM 7'-1" + 2 I.D. + T.
- ② REMOVABLE STOPPER-MASONRY, CAST IRON OR OTHER TYPES OF STOPPERS WILL BE PERMITTED IF APPROVED BY THE ENGINEER.
- ③ SEE CUR. STD. DWG. RDM-100 FOR CASTINGS TO BE USED IN NON-TRAFFIC AREAS AND CUR. STD. DWG. RDM-105 FOR CASTINGS TO BE USED IN TRAFFIC AREAS.
- ④ SEE CUR. STD. DWG. RDB-430 FOR STEP TYPE, SPACING AND DETAIL.
- ⑤ (G) & (H) BARS SPACED APPROXIMATELY 6" O.C. ALL OTHER BARS SPACED APPROXIMATELY 1'-0" O.C.
- ⑥ CONSTRUCTION JOINT NOT PERMITTED BELOW FLOW LINE ELEVATION.

7. ENCIRCLED LETTERS, ○, INDICATE STEEL BAR LOCATIONS.
8. T = PIPE THICKNESS, I.D. = INSIDE DIA. OF PIPE, O.D. = OUTSIDE DIA. OF PIPE.
- ⑨ 2'-0" DESIRED COVER, 1'-0" MINIMUM COVER OVER PIPE.
- ⑩ THE (H) BAR SHALL BE INCREASED INCH FOR INCH WHEN BOX EXCEEDS MINIMUM HEIGHT. ADD TWO (F) BARS FOR EACH 1'-0" INCREASE ABOVE MINIMUM HEIGHT.
11. DIMENSIONS FROM FACE OF CONCRETE TO STEEL SHALL BE 2" CLEAR DISTANCE.

KENTUCKY
DEPARTMENT OF HIGHWAYS

TRAPPED MANHOLE

STANDARD DRAWING NO. RDM-050-06

SUBMITTED: *John B. Sackett* DIRECTOR, DIVISION OF DESIGN 12-1-99
DATE

APPROVED: *J. M. Howell* STATE HIGHWAY ENGINEER 12-1-99
DATE