

PLAN VIEW

APPROX. CONCRETE QUANTITIES

PIPE SIZE	MIN. HEIGHT	CU. YDS. CONC.
15"	2'-11"	0.89
18"	3'-3"	0.97
24"	4'-9"	1.38
APPROXIMATE WEIGHTS		
FRAME		195 LBS.
GRATE		265 LBS.

NO DEDUCTIONS HAVE BEEN MADE FOR PIPE.

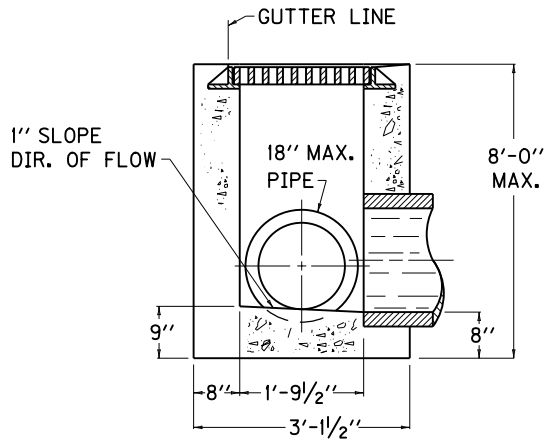

SECTION A-A

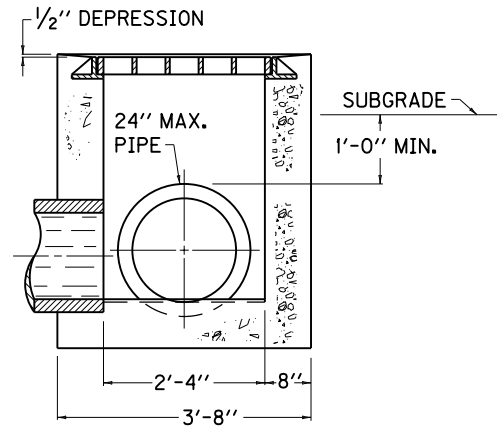

SECTION B-B

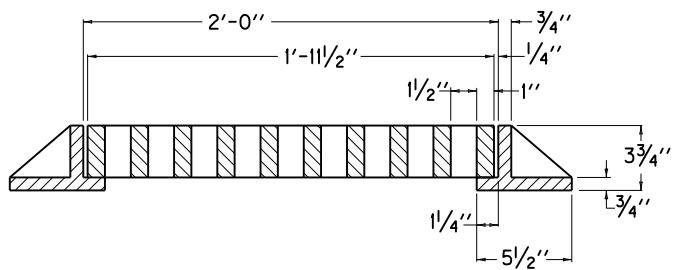

SECTIONAL VIEW OF FRAME AND GRATE

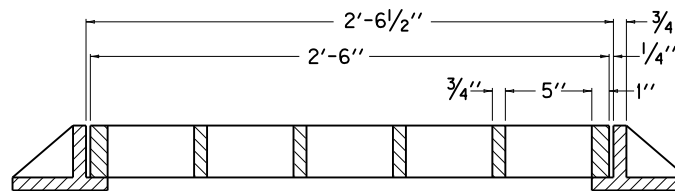

KENTUCKY DEPARTMENT OF HIGHWAYS	
DROP BOX INLET TYPE II	
STANDARD DRAWING NO. RDB-011-07	
SUBMITTED: <i>John B. Sackett</i> DIRECTOR, DIVISION OF DESIGN	12-1-99 DATE
APPROVED: <i>J. M. [Signature]</i> STATE HIGHWAY ENGINEER	12-1-99 DATE