



CALL NO. 401

CONTRACT ID. 192606

BARREN - METCALFE COUNTIES

FED/STATE PROJECT NUMBER 121GR19M058-FE02

DESCRIPTION DISTRICT 3 BRIDGE DECK REPAIRS

WORK TYPE BRIDGE DECK RESTORATION & WATERPROOFING

PRIMARY COMPLETION DATE 11/15/2020

LETTING DATE: August 23,2019

Sealed Bids will be received electronically through the Bid Express bidding service until 10:00 AM EASTERN DAYLIGHT TIME August 23,2019. Bids will be publicly announced at 10:00 AM EASTERN DAYLIGHT TIME.

NO PLANS ASSOCIATED WITH THIS PROJECT.

REQUIRED BID PROPOSAL GUARANTY: Not less than 5% of the total bid.

TABLE OF CONTENTS

PART I	SCOPE OF WORK
	<ul style="list-style-type: none">• PROJECT(S), COMPLETION DATE(S), & LIQUIDATED DAMAGES• CONTRACT NOTES• STATE CONTRACT NOTES• SPECIAL NOTE(S) APPLICABLE TO PROJECT• LIQUIDATED DAMAGES• TRAFFIC CONTROL PLAN• SKETCH MAP(S)• MATERIAL SUMMARY• BRIDGE DRAWINGS
PART II	SPECIFICATIONS AND STANDARD DRAWINGS
	<ul style="list-style-type: none">• SPECIFICATIONS REFERENCE• SUPPLEMENTAL SPECIFICATION
PART III	EMPLOYMENT, WAGE AND RECORD REQUIREMENTS
	<ul style="list-style-type: none">• LABOR AND WAGE REQUIREMENTS• EXECUTIVE BRANCH CODE OF ETHICS• KENTUCKY EQUAL EMPLOYMENT OPPORTUNITY ACT OF 1978 LOCALITY / STATE• PROJECT WAGE RATES / STATE
PART IV	INSURANCE
PART V	BID ITEMS

PART I
SCOPE OF WORK

ADMINISTRATIVE DISTRICT - 03

CONTRACT ID - 192606

121GR19M058-FE02

COUNTY - BARREN

PCN - MB00506851901
FE02 005 0685 B00062N

KY-685 (MP 2.185). BRIDGE OVER CUMBERLAND PKWY (LN-9008)BRIDGE DECK RESTORATION & WATERPROOFING

GEOGRAPHIC COORDINATES LATITUDE 37:00:47.00 LONGITUDE 86:01:28.00

PCN - MB00590081901
FE02 005 9008 B00071L

CUMBERLAND PKWY - LN-9008 (MP 11.498). BRIDGE OVER US 31EBRIDGE DECK RESTORATION & WATERPROOFING

GEOGRAPHIC COORDINATES LATITUDE 36:58:41.00 LONGITUDE 85:56:05.00

PCN - MB00590081902
FE02 005 9008 B00071R

CUMBERLAND PKWY - LN-9008 (MP 11.467). BRIDGE OVER US 31EBRIDGE DECK RESTORATION & WATERPROOFING

GEOGRAPHIC COORDINATES LATITUDE 36:58:41.00 LONGITUDE 85:56:06.00

COUNTY - METCALFE

PCN - MB08590081901
FE02 085 9008 B00040R

CUMBERLAND PKWY - LN-9008 (MP 24.134). BRIDGE OVER KY-640BRIDGE DECK RESTORATION & WATERPROOFING

GEOGRAPHIC COORDINATES LATITUDE 36:59:53.00 LONGITUDE 85:43:04.00

PCN - MB08590081902
FE02 085 9008 B00043L

CUMBERLAND PKWY - LN-9008 (MP 34.227). BRIDGE OVER EAST FK LITTLE BARRENBRIDGE DECK RESTORATION & WATERPROOFING

GEOGRAPHIC COORDINATES LATITUDE 37:01:37.00 LONGITUDE 85:32:42.00

PCN - MB08590081903
FE02 085 9008 B00043R

CUMBERLAND PKWY - LN-9008 (MP 34.226). BRIDGE OVER EAST FK LITTLE BARRENBRIDGE DECK RESTORATION & WATERPROOFING

GEOGRAPHIC COORDINATES LATITUDE 37:01:37.00 LONGITUDE 85:32:42.00

COMPLETION DATE(S):

COMPLETED BY 11/15/2020	APPLIES TO ENTIRE CONTRACT
30 CALENDAR Days	APPLIES TO 005B00062N
30 CALENDAR Days	APPLIES TO 005B00071L
30 CALENDAR Days	APPLIES TO 005B00071R
30 CALENDAR Days	APPLIES TO 085B00040R
30 CALENDAR Days	APPLIES TO 085B00043L
30 CALENDAR Days	APPLIES TO 085B00043R

CONTRACT NOTES

PROPOSAL ADDENDA

All addenda to this proposal must be applied when calculating bid and certified in the bid packet submitted to the Kentucky Department of Highways. Failure to use the correct and most recent addenda may result in the bid being rejected.

BID SUBMITTAL

Bidder must use the Department's electronic bidding software. The Bidder must download the bid file located on the Bid Express website (www.bidx.com) to prepare a bid packet for submission to the Department. The bidder must submit electronically using Bid Express.

JOINT VENTURE BIDDING

Joint venture bidding is permissible. All companies in the joint venture must be prequalified in one of the work types in the Qualifications for Bidders for the project. The bidders must get a vendor ID for the joint venture from the Division of Construction Procurement and register the joint venture as a bidder on the project. Also, the joint venture must obtain a digital ID from Bid Express to submit a bid. A joint bid bond of 5% may be submitted for both companies or each company may submit a separate bond of 5%.

UNDERGROUND FACILITY DAMAGE PROTECTION

The contractor shall make every effort to protect underground facilities from damage as prescribed in the Underground Facility Damage Protection Act of 1994, Kentucky Revised Statute KRS 367.4901 to 367.4917. It is the contractor's responsibility to determine and take steps necessary to be in compliance with federal and state damage prevention directives. When prescribed in said directives, the contractor shall submit Excavation Locate Requests to the Kentucky Contact Center (KY811) via web ticket entry. The submission of this request does not relieve the contractor from the responsibility of contacting non-member facility owners, whom shall be contacted through their individual Protection Notification Center. Non-compliance with these directives can result in the enforcement of penalties.

REGISTRATION WITH THE SECRETARY OF STATE BY A FOREIGN ENTITY

Pursuant to KRS 176.085(1)(b), an agency, department, office, or political subdivision of the Commonwealth of Kentucky shall not award a state contract to a person that is a foreign entity required by [KRS 14A.9-010](#) to obtain a certificate of authority to transact business in the Commonwealth ("certificate") from the Secretary of State under [KRS 14A.9-030](#) unless the person produces the certificate within fourteen (14) days of the bid or proposal opening. If the foreign entity is not required to obtain a certificate as provided in [KRS 14A.9-010](#), the foreign entity should identify the applicable exception. Foreign entity is defined within [KRS 14A.1-070](#).

For all foreign entities required to obtain a certificate of authority to transact business in the Commonwealth, if a copy of the certificate is not received by the contracting agency within the time frame identified above, the foreign entity's solicitation response shall be deemed non-responsive or the awarded contract shall be cancelled.

Businesses can register with the Secretary of State at <https://secure.kentucky.gov/sos/ftbr/welcome.aspx>.

SPECIAL NOTE FOR PROJECT QUESTIONS DURING ADVERTISEMENT

Questions about projects during the advertisement should be submitted in writing to the Division of Construction Procurement. This may be done by fax (502) 564-7299 or email to kytc.projectquestions@ky.gov. The Department will attempt to answer all submitted questions. The Department reserves the right not to answer if the question is not pertinent or does not aid in clarifying the project intent.

The deadline for posting answers will be 3:00 pm Eastern Daylight Time, the day preceding the Letting. Questions may be submitted until this deadline with the understanding that the later a question is submitted, the less likely an answer will be able to be provided.

The questions and answers will be posted for each Letting under the heading "Questions & Answers" on the Construction Procurement website (www.transportation.ky.gov/contract). The answers provided shall be considered part of this Special Note and, in case of a discrepancy, will govern over all other bidding documents.

HARDWOOD REMOVAL RESTRICTIONS

The US Department of Agriculture has imposed a quarantine in Kentucky and several surrounding states, to prevent the spread of an invasive insect, the emerald ash borer. Hardwood cut in conjunction with the project may not be removed from the state. Chipping or burning on site is the preferred method of disposal.

INSTRUCTIONS FOR EXCESS MATERIAL SITES AND BORROW SITES

Identification of excess material sites and borrow sites shall be the responsibility of the Contractor. The Contractor shall be responsible for compliance with all applicable state and federal laws and may wish to consult with the US Fish and Wildlife Service to seek protection under Section 10 of the Endangered Species Act for these activities.

ACCESS TO RECORDS

The contractor, as defined in KRS 45A.030 (9) agrees that the contracting agency, the Finance and Administration Cabinet, the Auditor of Public Accounts, and the Legislative Research Commission, or their duly authorized representatives, shall have access to any books, documents, papers, records, or other evidence, which are directly pertinent to this contract for the purpose of financial audit or program review. Records and other prequalification information confidentially

disclosed as part of the bid process shall not be deemed as directly pertinent to the contract and shall be exempt from disclosure as provided in KRS 61.878(1)(c). The contractor also recognizes that any books, documents, papers, records, or other evidence, received during a financial audit or program review shall be subject to the Kentucky Open Records Act, KRS 61.870 to 61.884.

In the event of a dispute between the contractor and the contracting agency, Attorney General, or the Auditor of Public Accounts over documents that are eligible for production and review, the Finance and Administration Cabinet shall review the dispute and issue a determination, in accordance with Secretary's Order 11-004.

April 30, 2018

SPECIAL NOTE FOR RECIPROCAL PREFERENCE

RECIPROCAL PREFERENCE TO BE GIVEN BY PUBLIC AGENCIES TO RESIDENT BIDDERS

By reference, KRS 45A.490 to 45A.494 are incorporated herein and in compliance regarding the bidders residency. Bidders who want to claim resident bidder status should complete the Affidavit for Claiming Resident Bidder Status along with their bid in the electronic bidding software. Submittal of the Affidavit should be done along the bid in Bid Express.

April 30, 2018

SPECIAL NOTE FOR REPLACING EXPANSION DAMS AND/OR INSTALLING ARMORED EDGES FOR CONCRETE ON BRIDGES

I. DESCRIPTION. Perform all work in accordance with the Kentucky Transportation Cabinet, Department of Highway's 2019 Standard Specifications for Road and Bridge Construction and applicable Supplemental Specifications, the Standard Drawings, this Note, and the attached detail drawings. Section references are to the Standard Specifications.

This work consists of the following: (1) Furnish all labor, materials, tools, and equipment; (2) Remove existing concrete and expansion device(s) and/or bridge ends; (3) Install armored edges and new concrete as specified and in accordance with the attached detail drawings; (4) Install new joint seals (where required); (5) Maintain and control traffic; and (6) Any other work specified as part of this contract.

II. MATERIALS.

A. Class "M" Concrete. Use either "M1" or "M2". See Section 601.

B. Structural Steel. Use new, commercial grade steel suitable for welding. The Engineer will base acceptance on visual inspection. For armored edges that make up the 4" neoperene joint, use Steelflex Strip Seal expansion joint by DS Brown, or approved equal. To be approved, armored edge extrusions must be embedded.

C. Stud Anchors. The armored edge stud anchors are ¾" embedded stud shear connectors conforming to ASTM A108, Grade 1015 (Nelson Studs or equal).

D. Steel Reinforcement. Use Grade 60. See Section 602.

E. Epoxy Bond Coat. See Section 511.

F. (2") Expansion Joint System. It shall have a cellular, or micro-cell, polyurethane foam impregnated with a hydrophobic acrylic emulsion, or a hydrophobic polymer. The polyurethane foam external facing shall be factory coated and cured with highway-grade, fuel resistant silicone or a highway-grade elastomeric coating at a width greater than the maximum joint expansion.

G. Neoprene Strip Seals. See attached detail drawings and Section 807.

III. EQUIPMENT.

A. Hammers. See Section 606.02.10 B.

B. Sawing Equipment. See Section 606.02.10 C.

C. Hydraulic Impact Equipment. See Section 606.02.10 D.

IV. CONSTRUCTION.

A. Remove Existing Materials. Remove existing Expansion Dam, Bridge End, Armored Edges and specified areas of concrete as shown on the attached sketches. Remove debris and/or expansion joint filler as directed by the Engineer. Clean and leave all existing steel reinforcement encountered in place. Damaged steel reinforcement will be repaired/replaced as directed by the Engineer at no additional cost to the Department.

Dispose of all removed material entirely away from the job site. This work is incidental to the contract unit price for "Expansion Joint Replacement" or "Armored Edge for Concrete".

B. Place New Concrete and Armored Edges. After all specified existing materials have been removed; place new armored edges to match the grade of the proposed overlay or to match the original grade (See attached detail drawings). Place the new Class "M" concrete to the scarified grade and finish to receive the new overlay or place the new Class "M" concrete to the original grade and finish with broom strokes drawn transversely from curb to curb.

All new structural steel shall be cleaned and painted in accordance with requirements of Section 607.03.23, except that surfaces to come in contact with concrete are not to be painted.

Blast clean all areas of existing concrete and structural steel to come in contact with new concrete until free of all laitance and deleterious substances immediately prior to the placement of the Class "M" Concrete. The surface areas of existing concrete to come in contact with the new Class "M" Concrete are to be coated with an epoxy bond coat immediately prior to placing new concrete in accordance with Section 511. The interfaces of the new and old concrete shall be as nearly vertical and horizontal as possible.

C. Additional Steel Reinforcement. Furnish for replacement, as directed by the Engineer, 2,400 linear feet of #4 steel reinforcing bars in 20' lengths. Place these bars in areas deemed by the Engineer to require additional reinforcement. Field cutting and bending is permitted. Do not place any additional steel reinforcement above the height of the top row of Nelson Studs on the armored edges. Ensure that all exposed steel reinforcement is tied in accordance with Section 602.03.04 prior to pouring the new Class "M" concrete. Deliver unused bars to the Local County Maintenance Barn. Payment will be made in accordance with Section 602.

D. Stage Construction. Installation of concrete and armored edges in two (or more if specified) stages is necessary. Join the armored edges at or near the centerline of the roadway or lane line, field weld and grind smooth.

E. (2''/2 1/2''/etc.) Expansion Joint System. System shall be installed in accordance with manufacturer's recommendations concerning approved adhesives, welds between sticks and appurtenances, and adhesion to concrete deck or armored edges. Joint seal is to be installed 1/2" recessed from the surface.

F. Preformed Neoprene Strip Seal. Place the preformed joint seal in one continuous, unbroken length. Place neoprene strip seals as recommended by the manufacturer and in accordance with Section 609.03.04

G. Shop Plans. Shop plans will not be required. The Contractor is responsible for obtaining field measurements and supplying properly sized materials to complete the work.

V. MEASUREMENT.

A. Expansion Joint Replacement – 2", 4". The Department will measure the quantity in linear feet from gutterline to gutterline along the centerline of the joint.

B. Armored Edge for Concrete. The Department will measure the quantity in linear feet from gutterline to gutterline along the face of the bridge end.

C. Steel Reinforcement. See Section 602.

VI. PAYMENT.

- A. Expansion Joint Replacement – 2", 4".** Payment at the contract unit price per linear foot is full compensation for removing specified existing materials, furnishing and installing the new armored edges, concrete, neoprene strip seal or pre-compressed horizontal expansion joint system, and all incidental items necessary to complete the work (except the overlay material) within the specified pay limits as specified by this note and as shown on the attached detail drawings.
- B. Armored Edge for Concrete.** Payment at the contract unit price per linear foot is full compensation for removing specified existing materials, furnishing and installing the new armored edges, concrete and all incidental items necessary to complete the work (except the overlay material) within the specified pay limits as specified by this note and as shown on the attached detail drawings.
- C. Steel Reinforcement.** See Section 602.

Residual lead paint may still be on bridge. The Contractor is advised to take all necessary protective measures including worker safety and environmental regulations when executing this work. The Department will not consider any claims based on residual lead paint.

SPECIAL NOTE FOR BRIDGE RESTORATION AND WATERPROOFING WITH CONCRETE OVERLAYS

- I. DESCRIPTION.** Perform all work in accordance with the Kentucky Transportation Cabinet, Department of Highway's 2019 Standard Specifications for Road and Bridge Construction and applicable Supplemental Specifications, the Standard Drawings, this Note, and the attached detail drawings. Section references are to the Standard Specifications.

This work consists of the following: (1) Furnish all labor, materials, tools, and equipment; (2) Remove the existing overlay or machine prep the existing slab; (3) Complete full-depth and partial depth repairs as directed by the Engineer; (4) Repair/replace damaged and corroded reinforcing bars; (5) Place new concrete overlay and epoxy-sand slurry in accordance with Section 606 except as stated below; (6) Complete asphalt approach pavement; (7) Maintain and control traffic; and (8) Any other work specified as part of this contract.

In contrast to Section 606, blast cleaning and installation of epoxy-sand slurry shall only be on the decks of the bridges, leaving the curbs and plinths with their existing coatings.

All other construction will be in accordance with Section 606 unless otherwise specified.

II. MATERIALS.

A. Latex Concrete. See Section 606.03.17.

B. Class "M" Concrete. Use either "M1" or "M2". See Section 601.

C. Bituminous Asphalt. Use CL3 ASPH SURF 0.5D PG76-22.

D. Epoxy-Sand Slurry. See Section 606.03.10.

III. CONSTRUCTION.

A. Machine prep of existing slab. For 005B00062N, 005B00071L, 005B00071R and 085B00040R, remove concrete from existing slab to a depth of at least ¼" below the existing surface, and remove all patches completely, in accordance with the requirements of Section 606.03.03. See Special Note for Use of Hydrodemolition Method.

B. Remove Existing Overlay. In addition to Section 606.03.03, totally remove the existing concrete overlay for 085B00043L and 085B00043R by milling. See Special Note for Use of Hydrodemolition Method.

C. Partial Depth Slab Repair and Latex Overlay. Remove areas determined to be unsound by the Engineer via hydrodemolition or via hand held jackhammers weighing less than 45lbs in accordance with Section 606.02.10 D. Repair/Replace all damaged or severely corroded reinforcing bars prior to partial depth repair operation. The Department will not measure material removal and will consider this work incidental to the bid item "PARTIAL DEPTH PATCHING". Mix and place Latex Modified Concrete Overlay in accordance with Sections 606.03.08 and 606.03.17.

D. Asphalt Approach Pavement. Mill each existing asphalt approach for a distance of 50' for 085B00043L and 085B00043R, and 100' for 005B00062N, 005B00071L,

005B00071R and 085B00040R, from the bridge ends. Remove the bituminous material uniformly by making an edge key, so as to provide a smooth transition to the finished bridge when a new bituminous overlay of compacted depth of approximately 1½” is added to the approaches. The grinding depth may vary depending of the condition of the existing approach and final elevation of bridge end. Dispose of all removed material away from the site.

E. Surface Texturing. Texture the concrete surface of the overlay in accordance with Section 609.03.10.

IV. MEASUREMENT. See Section 606 and the following:

A. Latex Modified Concrete for Concrete Overlay. The Department will measure the quantity in cubic yards using the theoretical volume as follows for each bridge:

005B00062N	(243’ x 26’ x 1.50’)	= 29.3 cuyd
005B00071L	(203’ x 30’ x 1.50’)	= 28.2 cuyd
005B00071R	(203’ x 30’ x 1.50’)	= 28.2 cuyd
085B00040R	(128’ x 39’ x 1.50’)	= 23.1 cuyd
085B00043L	(210’ x 30’ x 2.00’)	= 38.9 cuyd
085B00043R	(210’ x 30’ x 2.00’)	= 38.9 cuyd

B. Latex Modified Concrete for Partial Depth Patching and variable thickness of Overlay. The Department will measure the quantity in cubic yards by deducting the theoretical volume of bridge deck overlay (LMC) from the total volume (as indicated by the batch quantity tickets) of Concrete required to obtain the finished grade shown on the Plans or established by the Engineer.

C. Machine Prep of Slab. The Department will measure the machine preparation of the existing bridge deck for 005B00062N, 005B00071L, 005B00071R and 085B00040R in square yards, which shall include all labor, equipment, and material needed to complete this work.

D. Remove Existing Overlay. The Department will measure the removal of the existing overlay for 085B00043L and 085B00043R in square yards, which shall include all labor, equipment, and material needed to complete this work.

E. Steel Reinforcement. The Department will measure any reinforcing steel necessary for the partial or full depth patch in pounds, which shall include all labor, equipment, and material needed to complete this work.

F. Asphalt Approach Pavement. The Department will measure the quantity in square yards, which shall include all labor, equipment, and material needed to complete this work.

V. PAYMENT. See Section 606 and the following:

A. Latex Modified Concrete for Overlay. The Department will make payment for the Latex Modified Concrete under bid item #08534 “CONCRETE OVERLAY – LATEX” for the quantity in cubic yards complete in place.

- B. Latex Modified Concrete for Partial Depth Patching and variable thickness of Overlay.** The Department will make payment for the Partial Depth Patching under bid item #24094EC "PARTIAL DEPTH PATCHING". Payment will be for the quantity per cubic yard complete in place.
- C. Machine Prep of Slab.** The Department will make payment for the machine prep of existing slab for 005B00062N, 005B00071L, 005B00071R and 085B00040R, under bid item #08551 "MACHINE PREP OF SLAB". Payment will be for the square yard complete.
- D. Remove Existing Overlay.** The Department will make payment for the removal of the existing overlay for 085B00043L and 085B00043R under the bid item #08510 "REM EPOXY BIT FOREIGN OVERLAY". Payment will be for the square yard complete.
- E. Steel Reinforcement.** The Department will make payment for steel reinforcement, if necessary, under bid item #08150 "STEEL REINFORCEMENT". Payment will be at the unit price per pound.
- F. Asphalt Approach Pavement.** The Department will make payment for the completed and accepted quantity of this work under the bid item #03304 "BRIDGE OVERLAY APPROACH PAVEMENT".

CUMBERLAND PARKWAY BRIDGES
BARREN AND METCALFE COUNTIES
CID 192606

TYPICAL BARRIER WALL ARRANGEMENT (Fast Lane Closure Shown)

<u>BRIDGE</u>	<u>LENGTH (FT)</u>
005B00071L	203
005B00071R	203
085B00040R	128
085B00043L	210
085B00043R	210

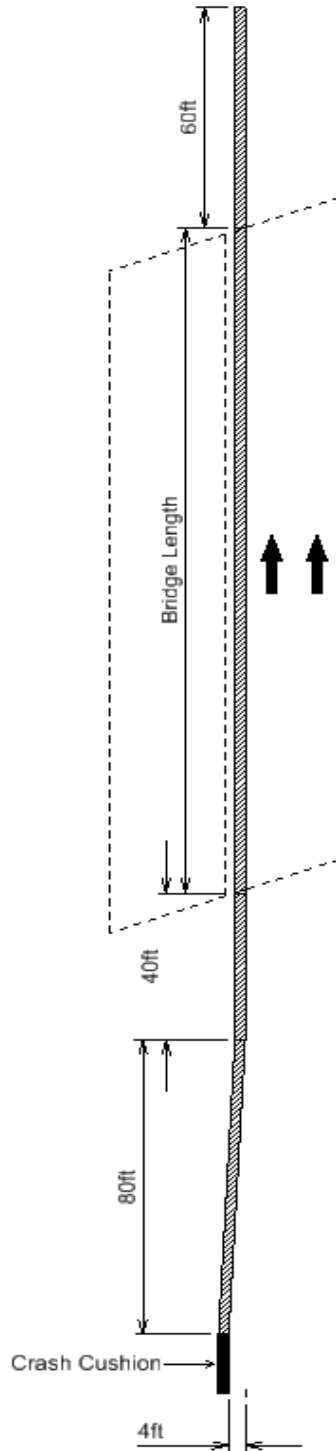

SPECIAL NOTE FOR CONTRACT COMPLETION DATE AND LIQUIDATED DAMAGES ON BRIDGE REPAIR CONTRACTS

I. COMPLETION DATE. The Contractor has the option of selecting the starting date for this Contract. Once selected, notify the Department in writing of the date selected at least two weeks prior to beginning work. All work is to be completed by November 15, 2020. An allotted number of Calendar days are assigned to each structure in this contract as shown below.

<u>STRUCTURE</u>	<u>NO. OF CALENDAR DAYS</u>	<u>COMPLETION DATE</u>
005B00062N	30	November 15, 2020
005B00071L	30	November 15, 2020
005B00071R	30	November 15, 2020
085B00040R	30	November 15, 2020
085B00043L	30	November 15, 2020
085B00043R	30	November 15, 2020

Contrary to Section 108.07.02, the Engineer will begin charging calendar days for a structure on the day the Contractor starts work or sets up traffic control on that particular structure.

II. LIQUIDATED DAMAGES. Liquidated damages will be assessed the Contractor in accordance with the Transportation Cabinet, Department of Highway’s 2019 Standard Specifications for Road and Bridge Construction, Section 108.09, when either the allotted number of calendar days or the November 15, 2020 date is exceeded.

Contrary to the Standard Specifications, liquidated damages will be assessed the Contractor during the months of December, January, February and March when the contract time has expired on any individual bridge or bridges. Contract time will be charged during these months.

All construction must be completed in accordance with the weather limitations specified in Section 606 and/or Section 601 as applicable. No extension of Contract time will be granted due to inclement weather or temperature limitations that occur due to starting work on the Contract or a structure late in the construction season.

SPECIAL NOTE FOR TRAFFIC CONTROL ON BRIDGE REPAIR CONTRACTS

I. TRAFFIC CONTROL GENERAL

Except as provided herein, traffic shall be maintained in accordance with the 2019 Standard Specifications, Section 112. Except for the roadway and traffic control bid items listed, all items of work necessary to maintain and control traffic will be paid at the lump sum bid price to “Maintain and Control Traffic”.

Contrary to Section 106.01, traffic control devices used on this project may be new or used in new condition, at the beginning of the work and maintained in like new condition until completion of the work.

II. TRAFFIC COORDINATOR

Furnish a Traffic Coordinator as per Section 112. The Traffic Coordinator shall inspect the project maintenance of traffic, at least three times daily, or as directed by the Engineer, during the Contractor’s operations and at any time a lane closure is in place. The personnel shall have access on the project to a radio or telephone to be used in case of emergencies or accidents.

The Traffic Coordinator shall report all incidents throughout the work zone to the Engineer on the project. The Contractor shall furnish the name and telephone number where the Traffic Coordinator can be contacted at all times.

III. SIGNS

Contrary to Section 112.04.02, only long term signs (sign intended to be continuously in place for more than 3 days) will be measured for payment; short term signs (signs intended to be left in place for 3 days or less) will not be measured for payment but will be incidental to Maintain and Control Traffic.

The contractor is to install warning signs for wide loads in advance of the bridge under the direction of the Engineer. The Department will not measure installation, maintenance, or removal for payment, and will consider these incidentals to Maintain and Control Traffic.

IV. TEMPORARY PAVEMENT STRIPING

Skip lines and/or solid lines through the length of the tapers for lane closures and other striping as directed by the Engineer shall be temporarily covered with 6” black removable tape. Permanent removal of all other pavement striping for traffic control shall be considered incidental to Maintain and Control Traffic. Temporary pavement striping shall be paid only once per course in accordance with Section 112.04.07. The Contractor shall replace any temporary striping that becomes damaged or fails to adhere to the pavement before dark on the day of the notification. Liquidated damages shall be assessed to the Contractor at a rate of \$500 per day for failing to replace temporary striping within this time limit.

V. PROJECT PHASING & CONSTRUCTION PROCEDURES

Maintain one lane of traffic during construction in accordance with Standard Drawing No. TTC-110 for lane closures, and the attached detail drawing. The minimum clear lane width required is as follows:

<u>Structure</u>	<u>Clear Lane Width</u>
005B00062N	10'-6"

The Contractor shall maintain one lane of traffic on Cumberland Parkway (LN-9008) at all times in accordance with Standard Drawing No. TTC-120 and the attached detail drawings. The clear lane width required is:

<u>Structure</u>	<u>Clear Lane Width</u>
005B00071L	12'-0"
005B00071R	12'-0"
085B00040R	12'-0"
085B00043L	12'-0"
085B00043R	12'-0"

Lane closures will not be permitted on these days:

Memorial Day Weekend (Friday-Monday)

Independence Day, when July 4th is on Tuesday, Wednesday, or Thursday; or

Independence Day Weekend, when July 4th is on Monday (Saturday-Monday) or Friday (Friday-Sunday)

Labor Day Weekend (Friday-Monday)

VI. TEMPORARY SIGNAL

Provide, install, and maintain a temporary traffic signal as specified below. The Contractor must provide a 24-hour contact person and number available to maintain the temporary signals as needed.

005B00062N 2 phase

VII. BARRIER WALL

Payment of the contract unit price per linear foot for "CONCRETE BARRIER WALL TYPE 9T" shall be full compensation for furnishing, installing, maintaining, adjusting alignment as needed, removing the barrier when no longer needed, and all incidental items necessary to complete the work.

Provide one side mounted barrier wall delineator per each section of barrier. See Standard Drawing RBM-020 for types. No direct payment allowed for delineators.

VIII. CRASH CUSHION / END TREATMENTS

To the satisfaction of the Engineer extend Barrier wall out of the clear zone. If Barrier wall is not extended out of the clear zone to the satisfaction of the engineer provide crash cushions / end treatments for the barrier wall.

Provide Barrier end treatments that comply with MASH-16.

BARREN AND METCALFE COUNTIES

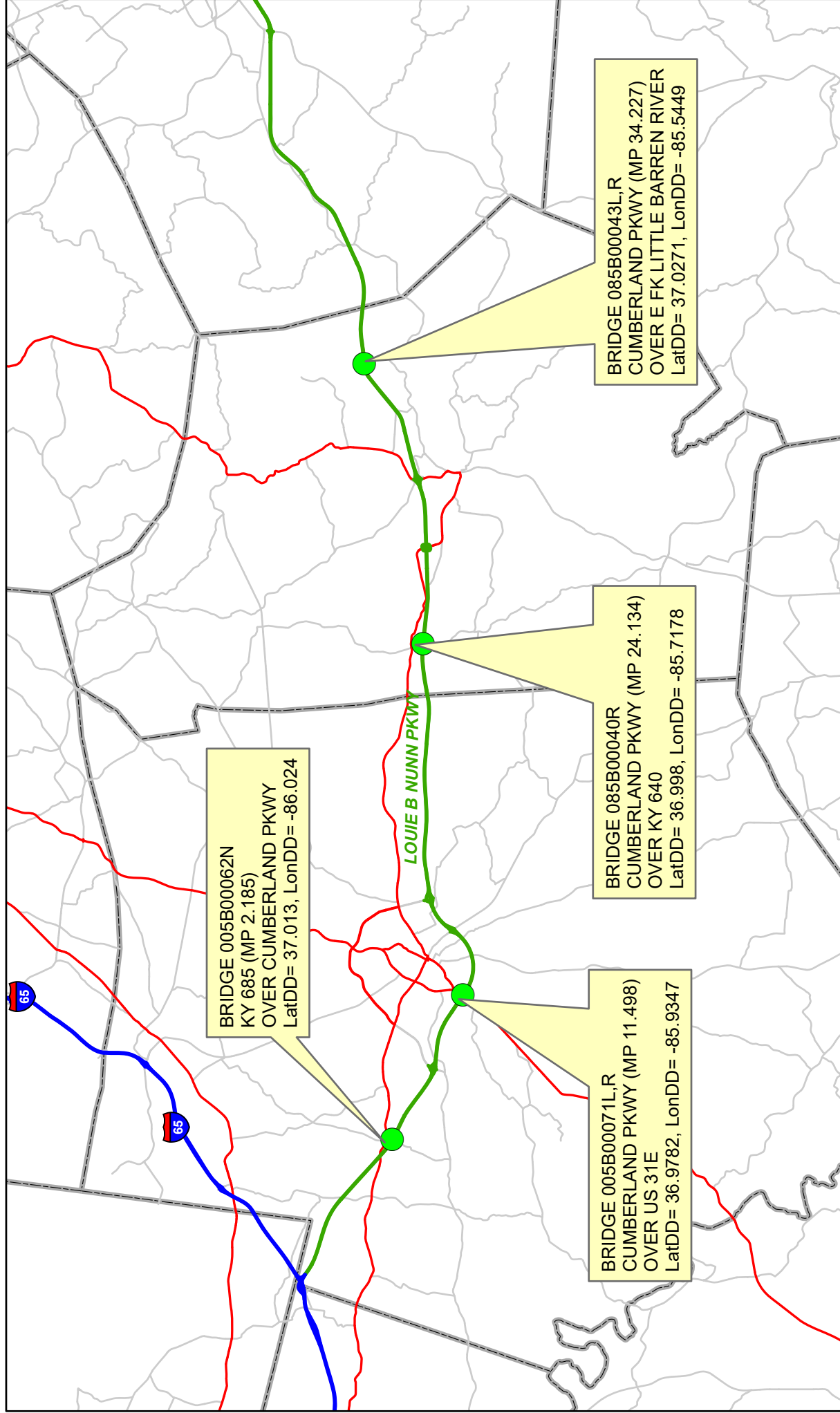
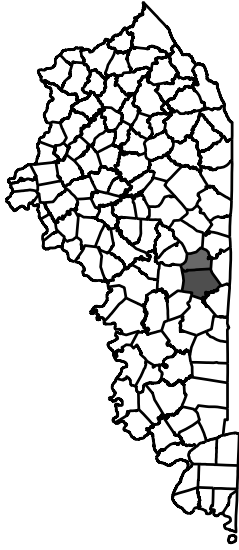

MATERIAL SUMMARY

CONTRACT ID: 192606

121GR19M058-FE02

MB00506851901

KY-685 (MP 2.185). BRIDGE OVER CUMBERLAND PKWY (LN-9008) BRIDGE DECK RESTORATION & WATERPROOFING.

Project Line No	Bid Code	DESCRIPTION	Quantity	Unit
0005	02562	TEMPORARY SIGNS	149.00	SQFT
0010	02650	MAINTAIN & CONTROL TRAFFIC - APPLIES TO 005B00062N	1.00	LS
0015	02653	LANE CLOSURE	2.00	EACH
0020	03298	EXPAN JOINT REPLACE 4 IN	55.40	LF
0025	03299	ARMORED EDGE FOR CONCRETE	55.40	LF
0030	03304	BRIDGE OVERLAY APPROACH PAVEMENT	578.00	SQYD
0035	04933	TEMP SIGNAL 2 PHASE	1.00	EACH
0040	06549	PAVE STRIPING-TEMP REM TAPE-B	500.00	LF
0045	06550	PAVE STRIPING-TEMP REM TAPE-W	1,000.00	LF
0050	06551	PAVE STRIPING-TEMP REM TAPE-Y	1,000.00	LF
0055	08150	STEEL REINFORCEMENT	267.20	LB
0060	08504	EPOXY SAND SLURRY	54.00	SQYD
0065	08526	CONC CLASS M FULL DEPTH PATCH	4.00	CUYD
0070	08534	CONCRETE OVERLAY-LATEX	29.30	CUYD
0075	08549	BLAST CLEANING	756.00	SQYD
0080	08551	MACHINE PREP OF SLAB	702.00	SQYD
0085	24094EC	PARTIAL DEPTH PATCHING	21.90	CUYD
0090	02569	DEMOBILIZATION	1.00	LS

MATERIAL SUMMARY

CONTRACT ID: 192606

121GR19M058-FE02

MB00590081901

CUMBERLAND PKWY - LN-9008 (MP 11.498). BRIDGE OVER US 31E BRIDGE DECK RESTORATION & WATERPROOFING.

Project Line No	Bid Code	DESCRIPTION	Quantity	Unit
0095	02003	RELOCATE TEMP CONC BARRIER	400.00	LF
0100	02562	TEMPORARY SIGNS	149.00	SQFT
0105	02650	MAINTAIN & CONTROL TRAFFIC - APPLIES TO 005B00071L	1.00	LS
0110	02653	LANE CLOSURE	2.00	EACH
0115	02671	PORTABLE CHANGEABLE MESSAGE SIGN	1.00	EACH
0120	02775	ARROW PANEL	1.00	EACH
0125	02898	RELOCATE CRASH CUSHION	1.00	EACH
0130	02900	INSTALL TEMP CRASH CUSHION	1.00	EACH
0135	03171	CONCRETE BARRIER WALL TYPE 9T	400.00	LF
0140	03295	EXPAN JOINT REPLACE 2 IN	60.20	LF
0145	03299	ARMORED EDGE FOR CONCRETE	60.20	LF
0150	03304	BRIDGE OVERLAY APPROACH PAVEMENT	667.00	SQYD
0155	06514	PAVE STRIPING-PERM PAINT-4 IN	933.20	LF
0160	06549	PAVE STRIPING-TEMP REM TAPE-B	500.00	LF
0165	06550	PAVE STRIPING-TEMP REM TAPE-W	1,000.00	LF
0170	06551	PAVE STRIPING-TEMP REM TAPE-Y	2,000.00	LF
0175	08150	STEEL REINFORCEMENT	267.20	LB
0180	08504	EPOXY SAND SLURRY	45.10	SQYD
0185	08526	CONC CLASS M FULL DEPTH PATCH	2.00	CUYD
0190	08534	CONCRETE OVERLAY-LATEX	28.20	CUYD
0195	08549	BLAST CLEANING	722.00	SQYD
0200	08551	MACHINE PREP OF SLAB	677.00	SQYD
0205	24094EC	PARTIAL DEPTH PATCHING	21.10	CUYD
0210	02569	DEMOBILIZATION	1.00	LS

MATERIAL SUMMARY

CONTRACT ID: 192606

121GR19M058-FE02

MB00590081902

CUMBERLAND PKWY - LN-9008 (MP 11.467). BRIDGE OVER US 31E BRIDGE DECK RESTORATION & WATERPROOFING.

Project Line No	Bid Code	DESCRIPTION	Quantity	Unit
0215	02003	RELOCATE TEMP CONC BARRIER	400.00	LF
0220	02562	TEMPORARY SIGNS	149.00	SQFT
0225	02650	MAINTAIN & CONTROL TRAFFIC - APPLIES TO 005B00071R	1.00	LS
0230	02653	LANE CLOSURE	2.00	EACH
0235	02671	PORTABLE CHANGEABLE MESSAGE SIGN	1.00	EACH
0240	02775	ARROW PANEL	1.00	EACH
0245	02898	RELOCATE CRASH CUSHION	1.00	EACH
0250	02900	INSTALL TEMP CRASH CUSHION	1.00	EACH
0255	03171	CONCRETE BARRIER WALL TYPE 9T	400.00	LF
0260	03295	EXPAN JOINT REPLACE 2 IN	60.20	LF
0265	03299	ARMORED EDGE FOR CONCRETE	60.20	LF
0270	03304	BRIDGE OVERLAY APPROACH PAVEMENT	667.00	SQYD
0275	06514	PAVE STRIPING-PERM PAINT-4 IN	933.20	LF
0280	06549	PAVE STRIPING-TEMP REM TAPE-B	500.00	LF
0285	06550	PAVE STRIPING-TEMP REM TAPE-W	1,000.00	LF
0290	06551	PAVE STRIPING-TEMP REM TAPE-Y	2,000.00	LF
0295	08150	STEEL REINFORCEMENT	267.20	LB
0300	08504	EPOXY SAND SLURRY	45.10	SQYD
0305	08526	CONC CLASS M FULL DEPTH PATCH	4.00	CUYD
0310	08534	CONCRETE OVERLAY-LATEX	28.20	CUYD
0315	08549	BLAST CLEANING	722.00	SQYD
0320	08551	MACHINE PREP OF SLAB	677.00	SQYD
0325	24094EC	PARTIAL DEPTH PATCHING	18.80	CUYD
0330	02569	DEMOBILIZATION	1.00	LS

MATERIAL SUMMARY

CONTRACT ID: 192606

121GR19M058-FE02

MB08590081901

CUMBERLAND PKWY - LN-9008 (MP 24.134). BRIDGE OVER KY-640 BRIDGE DECK RESTORATION & WATERPROOFING.

Project Line No	Bid Code	DESCRIPTION	Quantity	Unit
0335	02003	RELOCATE TEMP CONC BARRIER	320.00	LF
0340	02562	TEMPORARY SIGNS	149.00	SQFT
0345	02650	MAINTAIN & CONTROL TRAFFIC - APPLIES TO 085B00040R	1.00	LS
0350	02653	LANE CLOSURE	2.00	EACH
0355	02671	PORTABLE CHANGEABLE MESSAGE SIGN	1.00	EACH
0360	02775	ARROW PANEL	1.00	EACH
0365	02898	RELOCATE CRASH CUSHION	1.00	EACH
0370	02900	INSTALL TEMP CRASH CUSHION	1.00	EACH
0375	03171	CONCRETE BARRIER WALL TYPE 9T	320.00	LF
0380	03295	EXPAN JOINT REPLACE 2 IN	84.90	LF
0385	03299	ARMORED EDGE FOR CONCRETE	84.90	LF
0390	03304	BRIDGE OVERLAY APPROACH PAVEMENT	867.00	SQYD
0395	06514	PAVE STRIPING-PERM PAINT-4 IN	766.00	LF
0400	06549	PAVE STRIPING-TEMP REM TAPE-B	500.00	LF
0405	06550	PAVE STRIPING-TEMP REM TAPE-W	1,000.00	LF
0410	06551	PAVE STRIPING-TEMP REM TAPE-Y	2,000.00	LF
0415	08150	STEEL REINFORCEMENT	267.20	LB
0420	08504	EPOXY SAND SLURRY	28.40	SQYD
0425	08526	CONC CLASS M FULL DEPTH PATCH	2.00	CUYD
0430	08534	CONCRETE OVERLAY-LATEX	23.10	CUYD
0435	08549	BLAST CLEANING	583.00	SQYD
0440	08551	MACHINE PREP OF SLAB	555.00	SQYD
0445	24094EC	PARTIAL DEPTH PATCHING	17.30	CUYD
0450	02569	DEMOBILIZATION	1.00	LS

MATERIAL SUMMARY

CONTRACT ID: 192606

121GR19M058-FE02

MB08590081902

CUMBERLAND PKWY - LN-9008 (MP 34.227). BRIDGE OVER EAST FK LITTLE BARREN BRIDGE DECK RESTORATION & WATERPROOFING.

Project Line No	Bid Code	DESCRIPTION	Quantity	Unit
0455	02003	RELOCATE TEMP CONC BARRIER	400.00	LF
0460	02562	TEMPORARY SIGNS	149.00	SQFT
0465	02650	MAINTAIN & CONTROL TRAFFIC - APPLIES TO 085B00043L	1.00	LS
0470	02653	LANE CLOSURE	2.00	EACH
0475	02671	PORTABLE CHANGEABLE MESSAGE SIGN	1.00	EACH
0480	02775	ARROW PANEL	1.00	EACH
0485	02898	RELOCATE CRASH CUSHION	1.00	EACH
0490	02900	INSTALL TEMP CRASH CUSHION	1.00	EACH
0495	03171	CONCRETE BARRIER WALL TYPE 9T	400.00	LF
0500	03298	EXPAN JOINT REPLACE 4 IN	60.00	LF
0505	03299	ARMORED EDGE FOR CONCRETE	60.00	LF
0510	03304	BRIDGE OVERLAY APPROACH PAVEMENT	334.00	SQYD
0515	06514	PAVE STRIPING-PERM PAINT-4 IN	724.00	LF
0520	06549	PAVE STRIPING-TEMP REM TAPE-B	500.00	LF
0525	06550	PAVE STRIPING-TEMP REM TAPE-W	1,000.00	LF
0530	06551	PAVE STRIPING-TEMP REM TAPE-Y	2,000.00	LF
0535	08150	STEEL REINFORCEMENT	267.20	LB
0540	08504	EPOXY SAND SLURRY	46.70	SQYD
0545	08510	REM EPOXY BIT FOREIGN OVERLAY	700.00	SQYD
0550	08526	CONC CLASS M FULL DEPTH PATCH	2.00	CUYD
0555	08534	CONCRETE OVERLAY-LATEX	38.90	CUYD
0560	08549	BLAST CLEANING	747.00	SQYD
0565	24094EC	PARTIAL DEPTH PATCHING	19.40	CUYD
0570	02569	DEMOBILIZATION	1.00	LS

MATERIAL SUMMARY

CONTRACT ID: 192606

121GR19M058-FE02

MB08590081903

CUMBERLAND PKWY - LN-9008 (MP 34.226). BRIDGE OVER EAST FK LITTLE BARREN BRIDGE DECK RESTORATION & WATERPROOFING.

Project Line No	Bid Code	DESCRIPTION	Quantity	Unit
0575	02003	RELOCATE TEMP CONC BARRIER	400.00	LF
0580	02562	TEMPORARY SIGNS	149.00	SQFT
0585	02650	MAINTAIN & CONTROL TRAFFIC - APPLIES TO 085B00043R	1.00	LS
0590	02653	LANE CLOSURE	2.00	EACH
0595	02671	PORTABLE CHANGEABLE MESSAGE SIGN	1.00	EACH
0600	02775	ARROW PANEL	1.00	EACH
0605	02898	RELOCATE CRASH CUSHION	1.00	EACH
0610	02900	INSTALL TEMP CRASH CUSHION	1.00	EACH
0615	03171	CONCRETE BARRIER WALL TYPE 9T	400.00	LF
0620	03298	EXPAN JOINT REPLACE 4 IN	60.00	LF
0625	03299	ARMORED EDGE FOR CONCRETE	60.00	LF
0630	03304	BRIDGE OVERLAY APPROACH PAVEMENT	334.00	SQYD
0635	06514	PAVE STRIPING-PERM PAINT-4 IN	724.00	LF
0640	06549	PAVE STRIPING-TEMP REM TAPE-B	500.00	LF
0645	06550	PAVE STRIPING-TEMP REM TAPE-W	1,000.00	LF
0650	06551	PAVE STRIPING-TEMP REM TAPE-Y	2,000.00	LF
0655	08150	STEEL REINFORCEMENT	267.20	LB
0660	08504	EPOXY SAND SLURRY	46.70	SQYD
0665	08510	REM EPOXY BIT FOREIGN OVERLAY	700.00	SQYD
0670	08526	CONC CLASS M FULL DEPTH PATCH	3.00	CUYD
0675	08534	CONCRETE OVERLAY-LATEX	38.90	CUYD
0680	08549	BLAST CLEANING	747.00	SQYD
0685	24094EC	PARTIAL DEPTH PATCHING	19.40	CUYD
0690	02569	DEMOBILIZATION	1.00	LS

**ORIGINAL DESIGN DRAWING
18227 - SHEET 3
FOR REFERENCE ONLY**

005B00062N

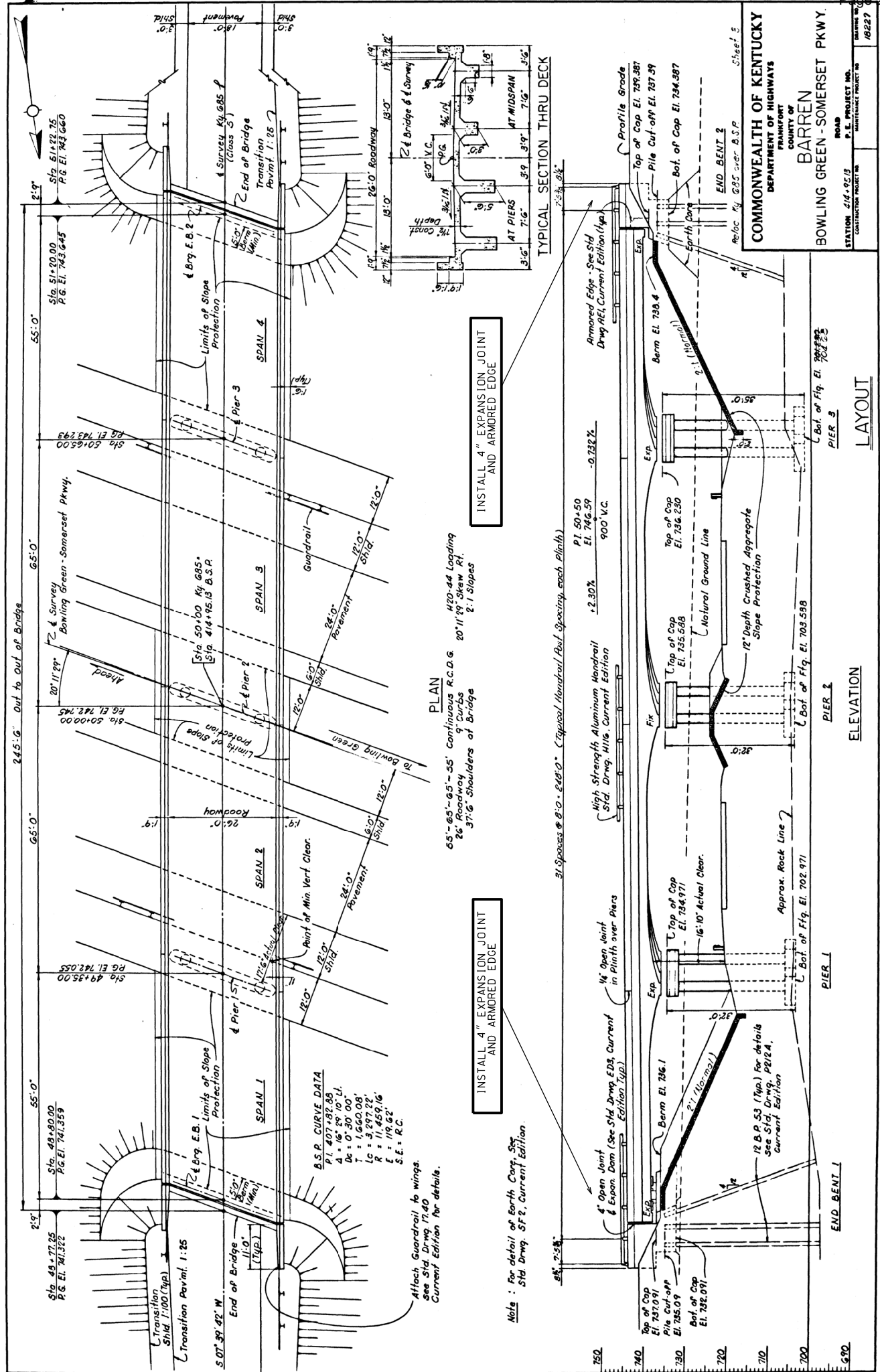

005B00071L
005B00071R
085B00040R

EXPANSION DAM DETAIL

Abutments #1 and #2

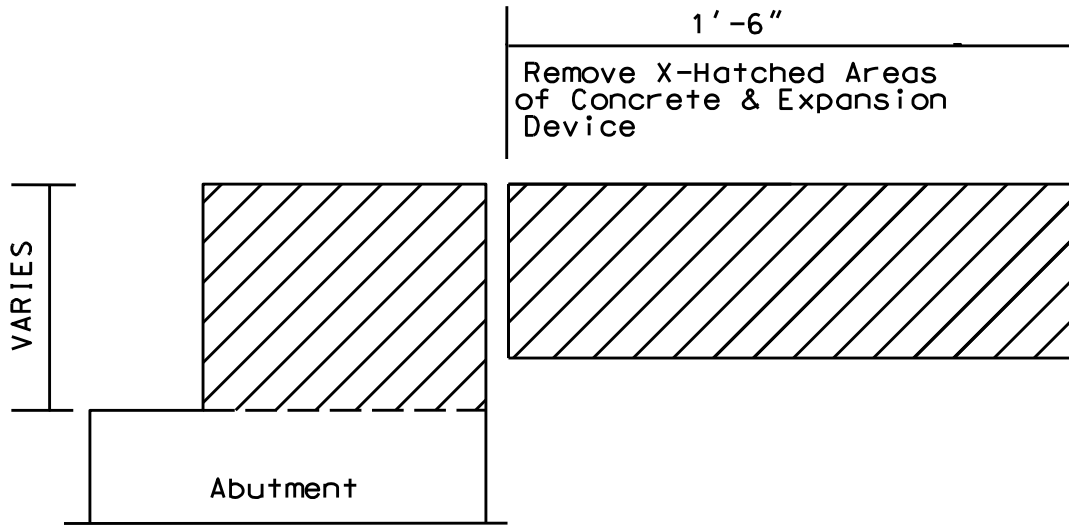

Clean & Leave
Steel Reinf.
in place.

EXISTING SECTION

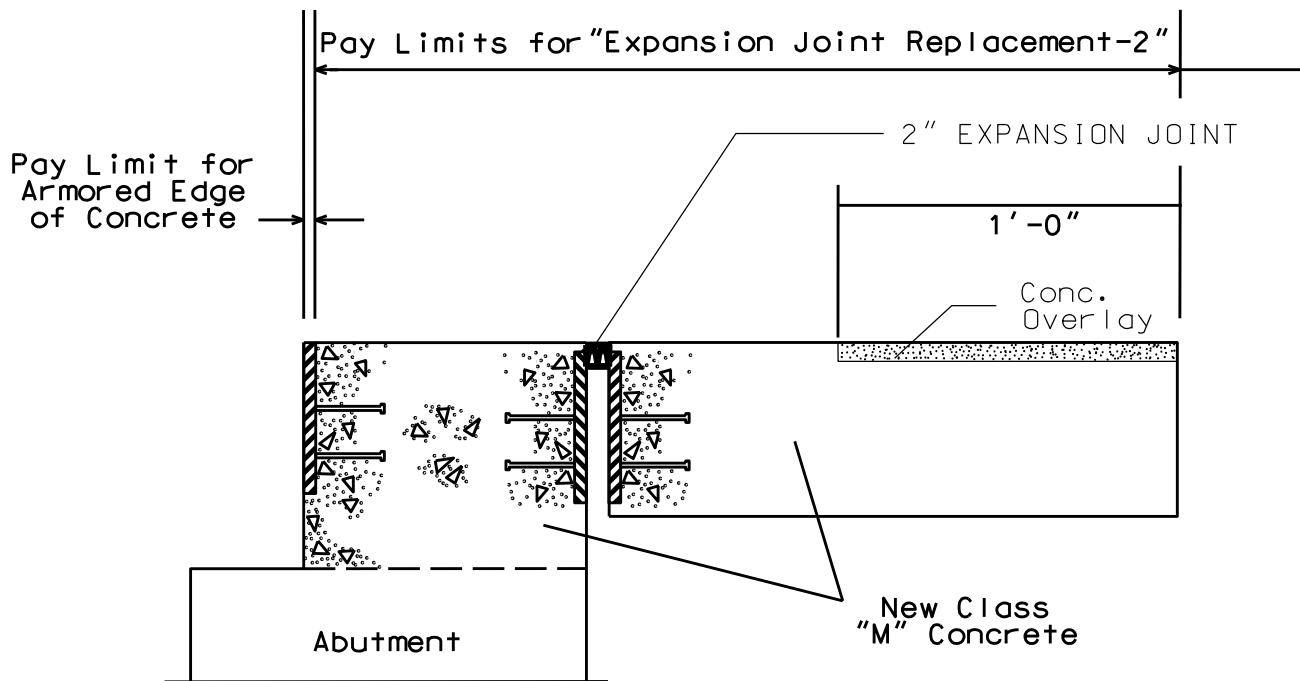

PROPOSED SECTION

005B000071L
005B000071R
085B000040R

CURB SECTION END BENTS

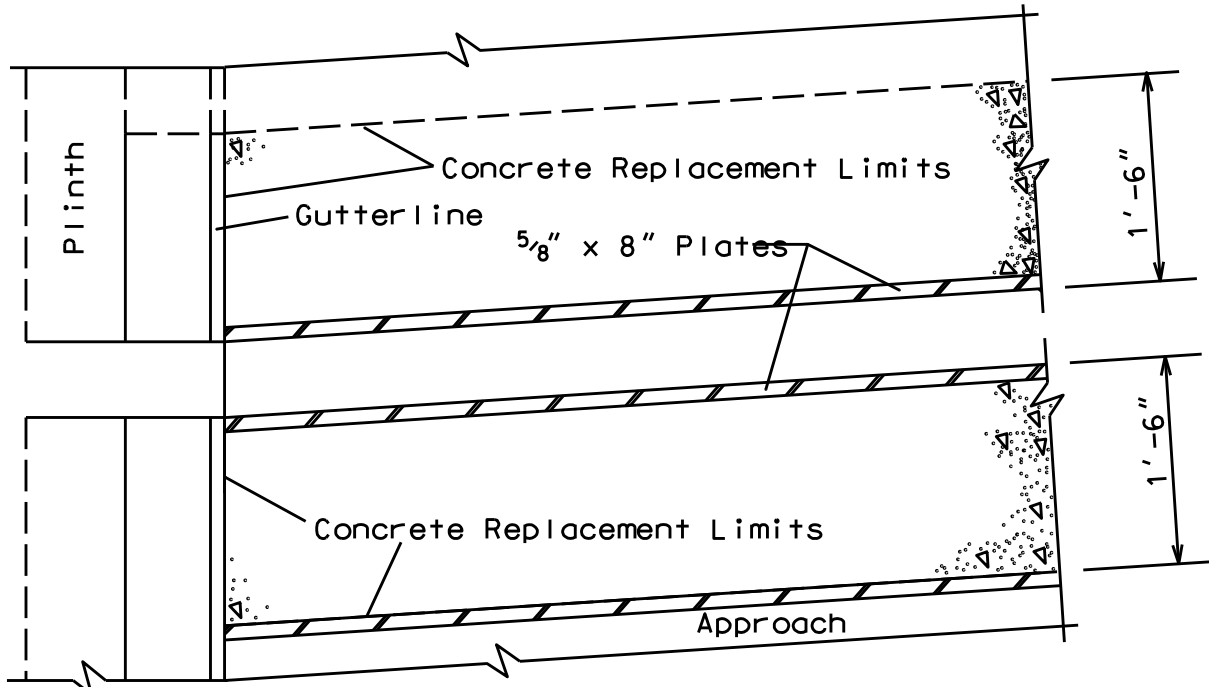

PLAN VIEW @ CURB

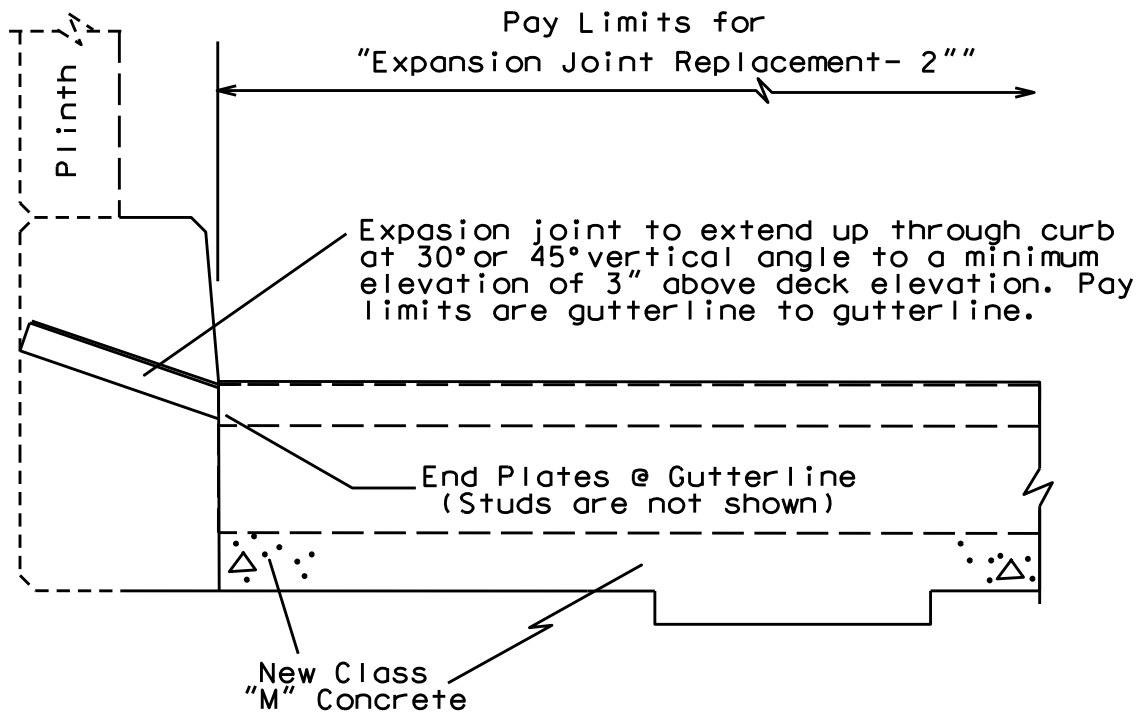

PROPOSED SECTION @ CURB

005B00062N
085B00043L
085B00043R

EXPANSION DAM DETAIL

Abutments #1 and #2

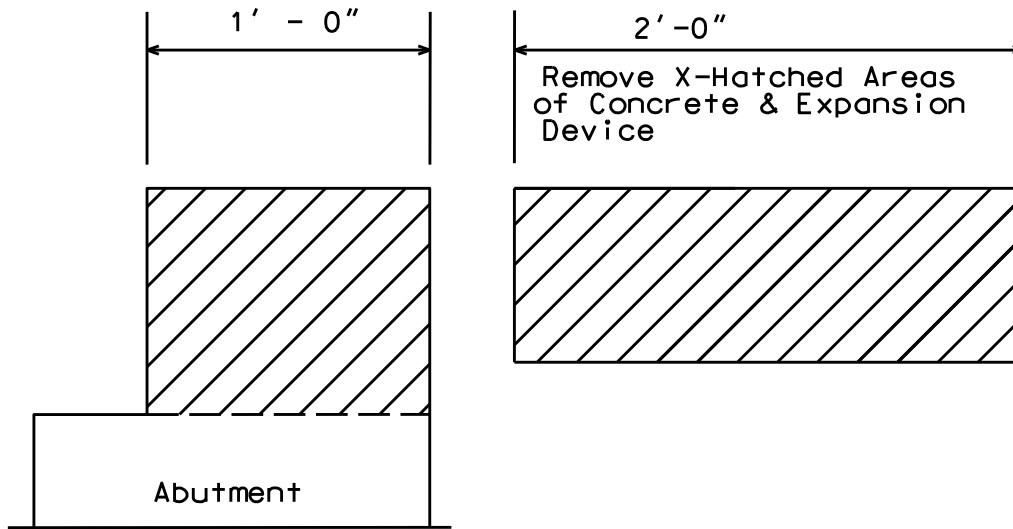

Clean & Leave
Steel Reinf.
in place.

EXISTING SECTION

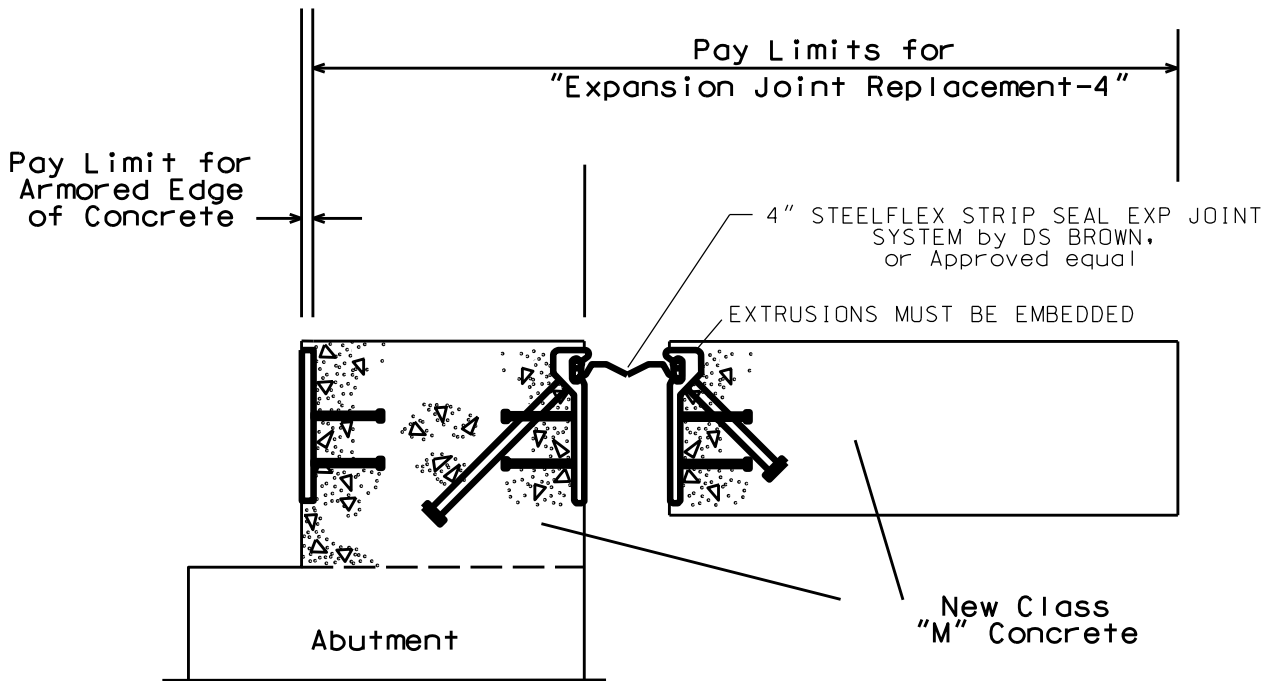

PROPOSED SECTION

005B000062N
085B000043L
085B000043R

CURB SECTION

ABUTMENT/END BENT

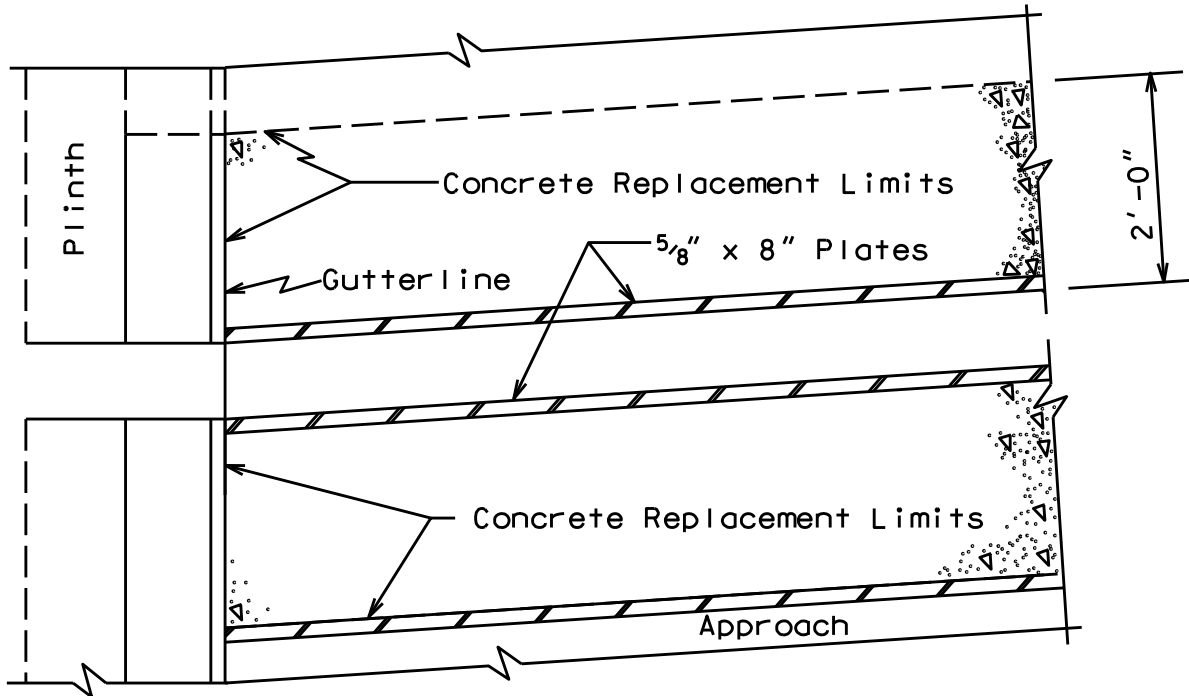

PLAN VIEW @ CURB

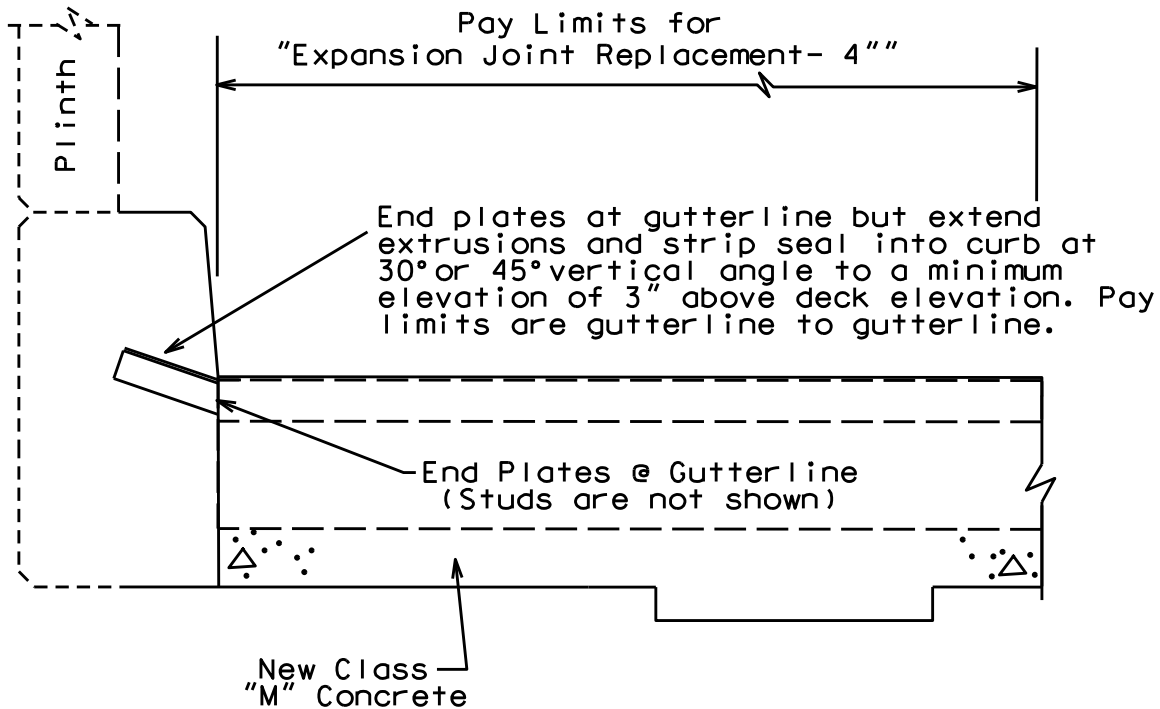

PROPOSED SECTION @ CURB

PART II
SPECIFICATIONS AND STANDARD DRAWINGS

SPECIFICATIONS REFERENCE

Any reference in the plans or proposal to previous editions of the *Standard Specifications for Road and Bridge Construction* and *Standard Drawings* are superseded by *Standard Specifications for Road and Bridge Construction, Edition of 2019* and *Standard Drawings, Edition of 2016*.

SUPPLEMENTAL SPECIFICATIONS

The contractor shall use the Supplemental Specifications that are effective at the time of letting.
The Supplemental Specifications can be found at the following link:

<http://transportation.ky.gov/Construction/Pages/Kentucky-Standard-Specifications.aspx>

PART III

EMPLOYMENT, WAGE AND RECORD REQUIREMENTS

**TRANSPORTATION CABINET
DEPARTMENT OF HIGHWAYS**

**LABOR AND WAGE REQUIREMENTS
APPLICABLE TO OTHER THAN FEDERAL-AID SYSTEM PROJECTS**

- I. Application
- II. Nondiscrimination of Employees (KRS 344)

I. APPLICATION

1. These contract provisions shall apply to all work performed on the contract by the contractor with his own organization and with the assistance of workmen under his immediate superintendence and to all work performed on the contract by piecework, station work or by subcontract. The contractor's organization shall be construed to include only workmen employed and paid directly by the contractor and equipment owned or rented by him, with or without operators.

2. The contractor shall insert in each of his subcontracts all of the stipulations contained in these Required Provisions and such other stipulations as may be required.

3. A breach of any of the stipulations contained in these Required Provisions may be grounds for termination of the contract.

3. If the contractor is in control of apprenticeship or other training or retraining, including on-the-job training programs, he shall not discriminate against an individual because of his race, color, religion, national origin, sex, disability or age forty (40) and over, in admission to, or employment in any program established to provide apprenticeship or other training.

4. The contractor will send to each labor union or representative of workers with which he has a collective bargaining agreement or other contract or understanding, a notice to be provided advising the said labor union or workers' representative of the contractor's commitments under this section, and shall post copies of the notice in conspicuous places available to employees and applicants for employment. The contractor will take such action with respect to any subcontract or purchase order as the administrating agency may direct as a means of enforcing such provisions, including sanctions for non-compliance.

Revised: January 25, 2017

II. NONDISCRIMINATION OF EMPLOYEES

**AN ACT OF THE KENTUCKY
GENERAL ASSEMBLY TO PREVENT
DISCRIMINATION IN EMPLOYMENT
KRS CHAPTER 344
EFFECTIVE JUNE 16, 1972**

The contract on this project, in accordance with KRS Chapter 344, provides that during the performance of this contract, the contractor agrees as follows:

1. The contractor shall not fail or refuse to hire, or shall not discharge any individual, or otherwise discriminate against an individual with respect to his compensation, terms, conditions, or privileges of employment, because of such individual's race, color, religion, national origin, sex, disability or age (forty and above); or limit, segregate, or classify his employees in any way which would deprive or tend to deprive an individual of employment opportunities or otherwise adversely affect his status as an employee, because of such individual's race, color, religion, national origin, sex, disability or age forty (40) and over. The contractor agrees to post in conspicuous places, available to employees and applicants for employment, notices to be provided setting forth the provisions of this nondiscrimination clause.

2. The contractor shall not print or publish or cause to be printed or published a notice or advertisement relating to employment by such an employer or membership in or any classification or referral for employment by the employment agency, indicating any preference, limitation, specification, or discrimination, based on race, color, religion, national origin, sex, or age forty (40) and over, or because the person is a qualified individual with a disability, except that such a notice or advertisement may indicate a preference, limitation, or specification based on religion, national origin, sex, or age forty (40) and over, or because the person is a qualified individual with a disability, when religion, national origin, sex, or age forty (40) and over, or because the person is a qualified individual with a disability, is a bona fide occupational qualification for employment.

EXECUTIVE BRANCH CODE OF ETHICS

In the 1992 regular legislative session, the General Assembly passed and Governor Brereton Jones signed Senate Bill 63 (codified as KRS 11A), the Executive Branch Code of Ethics, which states, in part:

KRS 11A.040 (7) provides:

No present or former public servant shall, within six (6) months following termination of his office or employment, accept employment, compensation, or other economic benefit from any person or business that contracts or does business with, or is regulated by, the state in matters in which he was directly involved during the last thirty-six (36) months of his tenure. This provision shall not prohibit an individual from returning to the same business, firm, occupation, or profession in which he was involved prior to taking office or beginning his term of employment, or for which he received, prior to his state employment, a professional degree or license, provided that, for a period of six (6) months, he personally refrains from working on any matter in which he was directly involved during the last thirty-six (36) months of his tenure in state government. This subsection shall not prohibit the performance of ministerial functions, including but not limited to filing tax returns, filing applications for permits or licenses, or filing incorporation papers, nor shall it prohibit the former officer or public servant from receiving public funds disbursed through entitlement programs.

KRS 11A.040 (9) states:

A former public servant shall not represent a person or business before a state agency in a matter in which the former public servant was directly involved during the last thirty-six (36) months of his tenure, for a period of one (1) year after the latter of:

- a) The date of leaving office or termination of employment; or
- b) The date the term of office expires to which the public servant was elected.

This law is intended to promote public confidence in the integrity of state government and to declare as public policy the idea that state employees should view their work as a public trust and not as a way to obtain private benefits.

If you have worked for the executive branch of state government within the past six months, you may be subject to the law's prohibitions. The law's applicability may be different if you hold elected office or are contemplating representation of another before a state agency.

Also, if you are affiliated with a firm which does business with the state and which employs former state executive-branch employees, you should be aware that the law may apply to them.

In case of doubt, the law permits you to request an advisory opinion from the Executive Branch Ethics Commission, 3 Fountain Place, Frankfort, Kentucky 40601; telephone (502) 564-7954.

Revised: January 27, 2017

Kentucky Equal Employment Opportunity Act of 1978

The requirements of the Kentucky Equal Employment Opportunity Act of 1978 (KRS 45.560-45.640) shall apply to this Contract. The apparent low Bidder will be required to submit EEO forms to the Division of Construction Procurement, which will then forward to the Finance and Administration Cabinet for review and approval. No award will become effective until all forms are submitted and EEO/CC has certified compliance. The required EEO forms are as follows:

- EEO-1: Employer Information Report
- Affidavit of Intent to Comply
- Employee Data Sheet
- Subcontractor Report

These forms are available on the Finance and Administration's web page under ***Vendor Information, Standard Attachments and General Terms*** at the following address:
<https://www.eProcurement.ky.gov>.

Bidders currently certified as being in compliance by the Finance and Administration Cabinet may submit a copy of their approval letter in lieu of the referenced EEO forms.

For questions or assistance please contact the Finance and Administration Cabinet by email at **finance.contractcompliance@ky.gov** or by phone at 502-564-2874.

EMPLOYEE RIGHTS UNDER THE FAIR LABOR STANDARDS ACT

THE UNITED STATES DEPARTMENT OF LABOR WAGE AND HOUR DIVISION

FEDERAL MINIMUM WAGE

\$7.25

 PER HOUR

BEGINNING JULY 24, 2009

OVERTIME PAY At least 1½ times your regular rate of pay for all hours worked over 40 in a workweek.

CHILD LABOR An employee must be at least **16** years old to work in most non-farm jobs and at least **18** to work in non-farm jobs declared hazardous by the Secretary of Labor.

Youths **14** and **15** years old may work outside school hours in various non-manufacturing, non-mining, non-hazardous jobs under the following conditions:

No more than

- **3** hours on a school day or **18** hours in a school week;
- **8** hours on a non-school day or **40** hours in a non-school week.

Also, work may not begin before **7 a.m.** or end after **7 p.m.**, except from June 1 through Labor Day, when evening hours are extended to **9 p.m.** Different rules apply in agricultural employment.

TIP CREDIT Employers of “tipped employees” must pay a cash wage of at least \$2.13 per hour if they claim a tip credit against their minimum wage obligation. If an employee’s tips combined with the employer’s cash wage of at least \$2.13 per hour do not equal the minimum hourly wage, the employer must make up the difference. Certain other conditions must also be met.

ENFORCEMENT The Department of Labor may recover back wages either administratively or through court action, for the employees that have been underpaid in violation of the law. Violations may result in civil or criminal action.

Employers may be assessed civil money penalties of up to \$1,100 for each willful or repeated violation of the minimum wage or overtime pay provisions of the law and up to \$11,000 for each employee who is the subject of a violation of the Act’s child labor provisions. In addition, a civil money penalty of up to \$50,000 may be assessed for each child labor violation that causes the death or serious injury of any minor employee, and such assessments may be doubled, up to \$100,000, when the violations are determined to be willful or repeated. The law also prohibits discriminating against or discharging workers who file a complaint or participate in any proceeding under the Act.

ADDITIONAL INFORMATION

- Certain occupations and establishments are exempt from the minimum wage and/or overtime pay provisions.
- Special provisions apply to workers in American Samoa and the Commonwealth of the Northern Mariana Islands.
- Some state laws provide greater employee protections; employers must comply with both.
- The law requires employers to display this poster where employees can readily see it.
- Employees under 20 years of age may be paid \$4.25 per hour during their first 90 consecutive calendar days of employment with an employer.
- Certain full-time students, student learners, apprentices, and workers with disabilities may be paid less than the minimum wage under special certificates issued by the Department of Labor.

For additional information:



1-866-4-USWAGE

(1-866-487-9243)

TTY: 1-877-889-5627



WWW.WAGEHOUR.DOL.GOV

PROPOSAL BID ITEMS

192606

Page 1 of 1

Report Date 7/26/19

Section: 0001 - BRIDGE

LINE	BID CODE	ALT	DESCRIPTION	QUANTITY	UNIT	UNIT PRIC	FP	AMOUNT
0010	02003		RELOCATE TEMP CONC BARRIER	1,920.00	LF		\$	
0020	02562		TEMPORARY SIGNS	894.00	SQFT		\$	
0030	02650		MAINTAIN & CONTROL TRAFFIC APPLIES TO 005B00062N	1.00	LS		\$	
0040	02650		MAINTAIN & CONTROL TRAFFIC APPLIES TO 005B00071L	1.00	LS		\$	
0050	02650		MAINTAIN & CONTROL TRAFFIC APPLIES TO 005B00071R	1.00	LS		\$	
0060	02650		MAINTAIN & CONTROL TRAFFIC APPLIES TO 085B00040R	1.00	LS		\$	
0070	02650		MAINTAIN & CONTROL TRAFFIC APPLIES TO 085B00043L	1.00	LS		\$	
0080	02650		MAINTAIN & CONTROL TRAFFIC APPLIES TO 085B00043R	1.00	LS		\$	
0090	02653		LANE CLOSURE	12.00	EACH		\$	
0100	02671		PORTABLE CHANGEABLE MESSAGE SIGN	5.00	EACH		\$	
0110	02775		ARROW PANEL	5.00	EACH		\$	
0120	02898		RELOCATE CRASH CUSHION	5.00	EACH		\$	
0130	02900		INSTALL TEMP CRASH CUSHION	5.00	EACH		\$	
0140	03171		CONCRETE BARRIER WALL TYPE 9T	1,920.00	LF		\$	
0150	03295		EXPAN JOINT REPLACE 2 IN	205.30	LF		\$	
0160	03298		EXPAN JOINT REPLACE 4 IN	175.40	LF		\$	
0170	03299		ARMORED EDGE FOR CONCRETE	380.70	LF		\$	
0180	03304		BRIDGE OVERLAY APPROACH PAVEMENT	3,447.00	SQYD		\$	
0190	04933		TEMP SIGNAL 2 PHASE	1.00	EACH		\$	
0200	06514		PAVE STRIPING-PERM PAINT-4 IN	4,080.40	LF		\$	
0210	06549		PAVE STRIPING-TEMP REM TAPE-B	3,000.00	LF		\$	
0220	06550		PAVE STRIPING-TEMP REM TAPE-W	6,000.00	LF		\$	
0230	06551		PAVE STRIPING-TEMP REM TAPE-Y	11,000.00	LF		\$	
0240	08150		STEEL REINFORCEMENT	1,603.20	LB		\$	
0250	08504		EPOXY SAND SLURRY	266.00	SQYD		\$	
0260	08510		REM EPOXY BIT FOREIGN OVERLAY	1,400.00	SQYD		\$	
0270	08526		CONC CLASS M FULL DEPTH PATCH	17.00	CUYD		\$	
0280	08534		CONCRETE OVERLAY-LATEX	186.60	CUYD		\$	
0290	08549		BLAST CLEANING	4,277.00	SQYD		\$	
0300	08551		MACHINE PREP OF SLAB	2,611.00	SQYD		\$	
0310	24094EC		PARTIAL DEPTH PATCHING	117.90	CUYD		\$	

Section: 0002 - DEMOBILIZATION

LINE	BID CODE	ALT	DESCRIPTION	QUANTITY	UNIT	UNIT PRIC	FP	AMOUNT
0320	02569		DEMOBILIZATION	1.00	LS		\$	