



CALL NO. 335

CONTRACT ID. 191028

PIKE COUNTY

FED/STATE PROJECT NUMBER FD04 098 0460 001-002

DESCRIPTION US-460

WORK TYPE PIPE REPLACEMENT

PRIMARY COMPLETION DATE 21 WORKING DAYS

LETTING DATE: May 24,2019

Sealed Bids will be received electronically through the Bid Express bidding service until 10:00 AM EASTERN DAYLIGHT TIME May 24,2019. Bids will be publicly announced at 10:00 AM EASTERN DAYLIGHT TIME.

NO PLANS ASSOCIATED WITH THIS PROJECT.

REQUIRED BID PROPOSAL GUARANTY: Not less than 5% of the total bid.

TABLE OF CONTENTS

PART I	SCOPE OF WORK
	<ul style="list-style-type: none">• PROJECT(S), COMPLETION DATE(S), & LIQUIDATED DAMAGES• CONTRACT NOTES• STATE CONTRACT NOTES• SPECIAL NOTE(S) APPLICABLE TO PROJECT• RIGHT OF WAY NOTES• UTILITY IMPACT & RAIL CERTIFICATION NOTES
PART II	SPECIFICATIONS AND STANDARD DRAWINGS
	<ul style="list-style-type: none">• SPECIFICATIONS REFERENCE• SUPPLEMENTAL SPECIFICATION• [SN-11E] BORING AND JACKING STEEL PIPE WITHOUT CARRIER PIPE
PART III	EMPLOYMENT, WAGE AND RECORD REQUIREMENTS
	<ul style="list-style-type: none">• LABOR AND WAGE REQUIREMENTS• EXECUTIVE BRANCH CODE OF ETHICS• KENTUCKY EQUAL EMPLOYMENT OPPORTUNITY ACT OF 1978 LOCALITY / STATE• PROJECT WAGE RATES / STATE
PART IV	INSURANCE
PART V	BID ITEMS

PART I
SCOPE OF WORK

ADMINISTRATIVE DISTRICT - 12

CONTRACT ID - 191028

FD04 098 0460 001-002

COUNTY - PIKE

PCN - DE09804601928

FD04 098 0460 001-002

US-460 RECONSTRUCTION OF DRAINAGE PIPE SYSTEM UNDER US-460 BETWEEN MP 1.15 AND MP 1.20, A
DISTANCE OF 0.05 MILES. PIPE REPLACEMENT SYP NO. 12-00348.00.
GEOGRAPHIC COORDINATES LATITUDE 37:25:41.00 LONGITUDE 82:30:10.00

COMPLETION DATE(S):

21 WORKING Days

APPLIES TO ENTIRE CONTRACT

CONTRACT NOTES

PROPOSAL ADDENDA

All addenda to this proposal must be applied when calculating bid and certified in the bid packet submitted to the Kentucky Department of Highways. Failure to use the correct and most recent addenda may result in the bid being rejected.

BID SUBMITTAL

Bidder must use the Department's electronic bidding software. The Bidder must download the bid file located on the Bid Express website (www.bidx.com) to prepare a bid packet for submission to the Department. The bidder must submit electronically using Bid Express.

JOINT VENTURE BIDDING

Joint venture bidding is permissible. All companies in the joint venture must be prequalified in one of the work types in the Qualifications for Bidders for the project. The bidders must get a vendor ID for the joint venture from the Division of Construction Procurement and register the joint venture as a bidder on the project. Also, the joint venture must obtain a digital ID from Bid Express to submit a bid. A joint bid bond of 5% may be submitted for both companies or each company may submit a separate bond of 5%.

UNDERGROUND FACILITY DAMAGE PROTECTION

The contractor shall make every effort to protect underground facilities from damage as prescribed in the Underground Facility Damage Protection Act of 1994, Kentucky Revised Statute KRS 367.4901 to 367.4917. It is the contractor's responsibility to determine and take steps necessary to be in compliance with federal and state damage prevention directives. When prescribed in said directives, the contractor shall submit Excavation Locate Requests to the Kentucky Contact Center (KY811) via web ticket entry. The submission of this request does not relieve the contractor from the responsibility of contacting non-member facility owners, whom shall be contacted through their individual Protection Notification Center. Non-compliance with these directives can result in the enforcement of penalties.

REGISTRATION WITH THE SECRETARY OF STATE BY A FOREIGN ENTITY

Pursuant to KRS 176.085(1)(b), an agency, department, office, or political subdivision of the Commonwealth of Kentucky shall not award a state contract to a person that is a foreign entity required by [KRS 14A.9-010](#) to obtain a certificate of authority to transact business in the Commonwealth ("certificate") from the Secretary of State under [KRS 14A.9-030](#) unless the person produces the certificate within fourteen (14) days of the bid or proposal opening. If the foreign entity is not required to obtain a certificate as provided in [KRS 14A.9-010](#), the foreign entity should identify the applicable exception. Foreign entity is defined within [KRS 14A.1-070](#).

For all foreign entities required to obtain a certificate of authority to transact business in the Commonwealth, if a copy of the certificate is not received by the contracting agency within the time frame identified above, the foreign entity's solicitation response shall be deemed non-responsive or the awarded contract shall be cancelled.

Businesses can register with the Secretary of State at <https://secure.kentucky.gov/sos/ftbr/welcome.aspx>.

SPECIAL NOTE FOR PROJECT QUESTIONS DURING ADVERTISEMENT

Questions about projects during the advertisement should be submitted in writing to the Division of Construction Procurement. This may be done by fax (502) 564-7299 or email to kytc.projectquestions@ky.gov. The Department will attempt to answer all submitted questions. The Department reserves the right not to answer if the question is not pertinent or does not aid in clarifying the project intent.

The deadline for posting answers will be 3:00 pm Eastern Daylight Time, the day preceding the Letting. Questions may be submitted until this deadline with the understanding that the later a question is submitted, the less likely an answer will be able to be provided.

The questions and answers will be posted for each Letting under the heading "Questions & Answers" on the Construction Procurement website (www.transportation.ky.gov/contract). The answers provided shall be considered part of this Special Note and, in case of a discrepancy, will govern over all other bidding documents.

HARDWOOD REMOVAL RESTRICTIONS

The US Department of Agriculture has imposed a quarantine in Kentucky and several surrounding states, to prevent the spread of an invasive insect, the emerald ash borer. Hardwood cut in conjunction with the project may not be removed from the state. Chipping or burning on site is the preferred method of disposal.

INSTRUCTIONS FOR EXCESS MATERIAL SITES AND BORROW SITES

Identification of excess material sites and borrow sites shall be the responsibility of the Contractor. The Contractor shall be responsible for compliance with all applicable state and federal laws and may wish to consult with the US Fish and Wildlife Service to seek protection under Section 10 of the Endangered Species Act for these activities.

ACCESS TO RECORDS

The contractor, as defined in KRS 45A.030 (9) agrees that the contracting agency, the Finance and Administration Cabinet, the Auditor of Public Accounts, and the Legislative Research Commission, or their duly authorized representatives, shall have access to any books, documents, papers, records, or other evidence, which are directly pertinent to this contract for the purpose of financial audit or program review. Records and other prequalification information confidentially

disclosed as part of the bid process shall not be deemed as directly pertinent to the contract and shall be exempt from disclosure as provided in KRS 61.878(1)(c). The contractor also recognizes that any books, documents, papers, records, or other evidence, received during a financial audit or program review shall be subject to the Kentucky Open Records Act, KRS 61.870 to 61.884.

In the event of a dispute between the contractor and the contracting agency, Attorney General, or the Auditor of Public Accounts over documents that are eligible for production and review, the Finance and Administration Cabinet shall review the dispute and issue a determination, in accordance with Secretary's Order 11-004.

April 30, 2018

SPECIAL NOTE FOR RECIPROCAL PREFERENCE

RECIPROCAL PREFERENCE TO BE GIVEN BY PUBLIC AGENCIES TO RESIDENT BIDDERS

By reference, KRS 45A.490 to 45A.494 are incorporated herein and in compliance regarding the bidders residency. Bidders who want to claim resident bidder status should complete the Affidavit for Claiming Resident Bidder Status along with their bid in the electronic bidding software. Submittal of the Affidavit should be done along the bid in Bid Express.

April 30, 2018

COUNTY OF	ITEM NO.	SHEET NO.
PIKE	12-348.00	R1

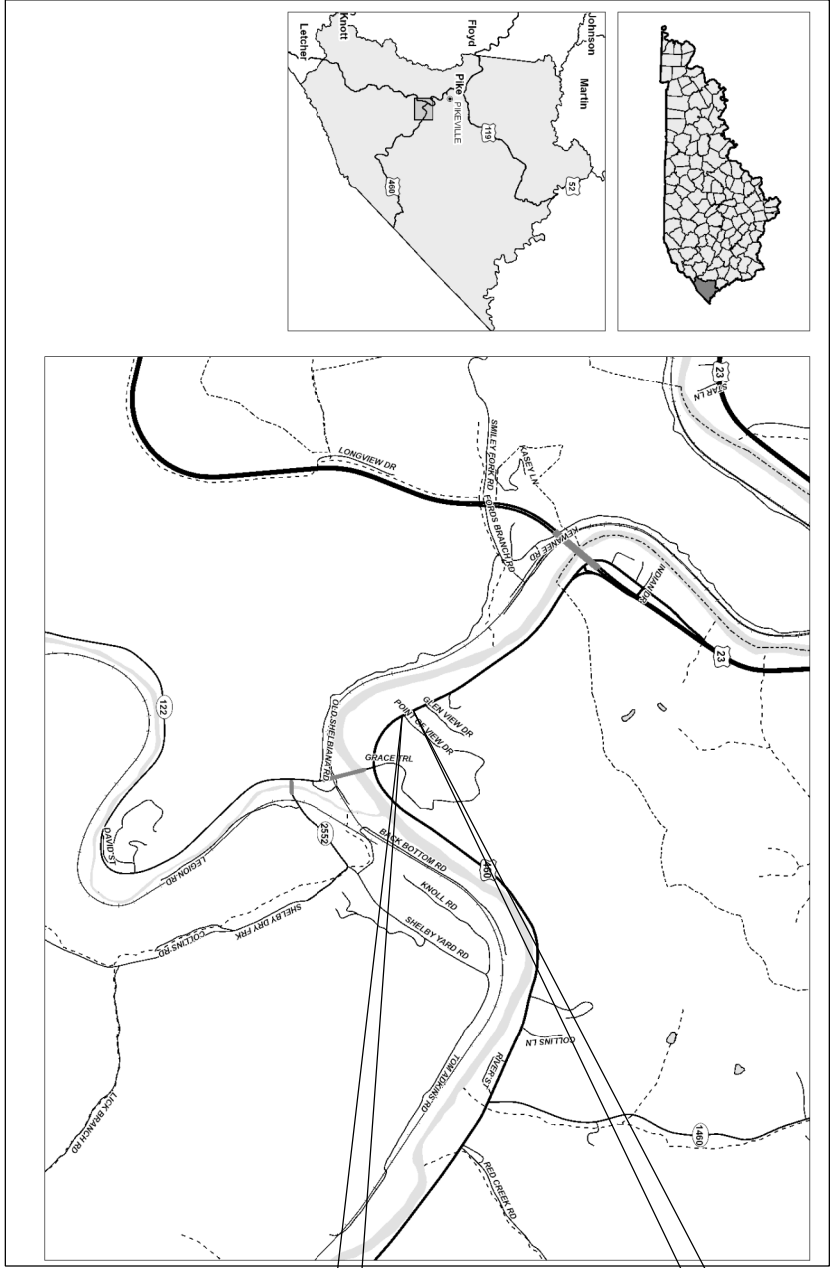
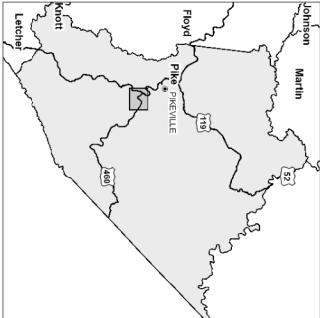
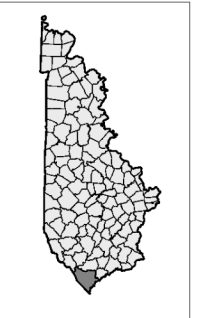

BEGIN CONSTRUCTION
STA. 1+68.09

END CONSTRUCTION
STA. 3+77.41



LAYOUT MAP
NOT TO SCALE
Commonwealth of Kentucky
DEPARTMENT OF HIGHWAYS

PLANS OF
PROPOSED PROJECT
PIKE COUNTY
FD04 098 0460 001-002
US 460 DRAINAGE RECONSTRUCTION
NEAR SHELBIANA

INDEX OF SHEETS

SHEET NO.	DESCRIPTION
R1	LAYOUT SHEET
R2	GENERAL SUMMARY
R3	PLAN AND LEGEND
R4-R7	PLAN SECTIONS
R8-R10	CROSS SECTIONS

Layout Sheet

GENERAL SUMMARY

COUNTY OF	ITEM NO.	SHEET NO.
PIKE	12-0348	R2

ITEM	DESCRIPTION	UNIT				
02562	TEMPORARY STONS	SQ.FT.	105			
02569	DEMOLITION	LS	1			
02650	MAINTAIN & CONTROL TRAFFIC	LS	1			
02701	TEMPORARY SILT FENCE	LN.FT.	369			
02704	SILT TRAP TYPE B	EACH	2			
02707	CLEAN SILT TRAP TYPE B	EACH	2			
02705	SILT TRAP TYPE C	EACH	1			
02708	CLEAN SILT TRAP TYPE C	EACH	1			
02726	STAKING	LS	1			
05963	INITIAL FERTILIZER	TON	0.02			
05964	MAINTENANCE FERTILIZER	TON	0.02			
05985	SEEDING AND PROTECTION	SQ.YD.	239			
05992	AGRICULTURAL LIMESTONE	TON	0.02			

PIPE DRAINAGE SUMMARY

SHEET NO.		SKREW	CLASS II CHANNEL LINING	DROP BOX INLET TY 1 (SAG)	PIPE CULVERT HEADWALL 24 INCH	BORE AND JACK 24 INCH PIPE	STORM SEWER PIPE 24 INCH	MANHOLE TYPE B	GEOTEXTILE FABRIC TYPE IV FOR PIPE	DITCH EXCAVATION	FLOWABLE FILL	REMARKS
ITEM CODE												
UNIT TO BID												
PIPE 1	10	EA	61				183.4	1	326		22	
PIPE 2	10	EA	1				252.0		449	10		
PIPE 3	10	EA	1				① 435.4	1	775	10	22	②
TOTAL PROJECT	20	1	2	61			③ 435.4	1	775	10	22	②

- ① 24" STORM SEWER PIPE SHALL BE HDPE OR PVC PIPE, NO ALTERNATES.
- ② FLOWABLE FILL TO BE CONSTRUCTED FROM APPROXIMATE PIPE CENTERLINE STA. 11+30 TO APPROXIMATE PIPE CENTERLINE STA. 11+90. CONSTRUCT FLOWABLE FILL TO 1' ABOVE THE TOP OF THE PROPOSED STORM SEWER BETWEEN THESE STATIONS. PAYMENT SHALL BE MADE BY PLAN QUANTITY.
- ③ ANY SHEETING, SHORING, OR OTHER ACTIVITIES REQUIRED TO INSTALL THE STORM SEWER SYSTEM SHALL BE INCIDENTAL TO STORM SEWER PIPE-24".

CONVENTIONAL SIGNS

SURVEY LINE
 GRADE LINE
 GROUND LINE
 COUNTY LINE
 CORPORATE LIMITS
 EXIST. PROPERTY LINE
 PROPOSED RIGHT OF WAY
 RIGHT OF WAY MONUMENT

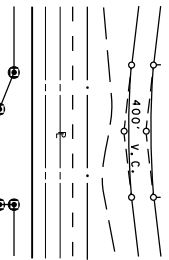

B. M. NO. 4

165

BEFORE YOU DIG

EXISTING R/W MARKER
 RIGHT OF WAY MONUMENT
 EXISTING/PROPOSED
 UTILITY TEST HOLE
 EXISTING ROAD
 RAILROAD
 FENCE (EXCEPT STONE AND HEDGE)
 TREE LINE
 TREES
 PIPE CULVERT
 CULVERT
 BRIDGE
 BUILDINGS
 GUARDRAIL

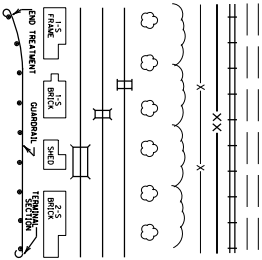

EXISTING

PROPOSED

650

STANDARD DRAWINGS

STANDARD DRAWINGS ARE NOT ATTACHED TO THESE PLANS. A STANDARD DRAWING BOOK AND THE HEADWALL SUPPLEMENTAL BOOK MAY BE OBTAINED FROM THE POLICY SUPPORT BRANCH OF THE DEPARTMENT OF ADMINISTRATIVE SERVICES IN FRANKFORT, KY AT (502)564-3670.

WATER MAIN
 GAS MAIN
 TELEPHONE DUCT
 ELECTRIC DUCT
 DIRECT BURIAL TV CABLE
 SANITARY BURIAL (WITH MANHOLE)
 STORM SEWER (WITH MANHOLE)
 DIRECT BURIAL, ELECTRIC CABLE
 DIRECT BURIAL, TELEPHONE CABLE
 OVERHEAD WIRE
 TRAFFIC LIGHTS
 ELECTRIC MANHOLE
 TELEPHONE MANHOLE
 STONE FENCE
 HEDGE FENCE
 SWAMP OR MARSH
 SPRINGS
 SINKHOLE
 QUARRY SITE
 BLUE LINE STREAM
 INTERMITTENT STREAM
 OR DITCH
 LAKES OR PONDS
 REGULATED FLOODWAY
 NORTH POINT

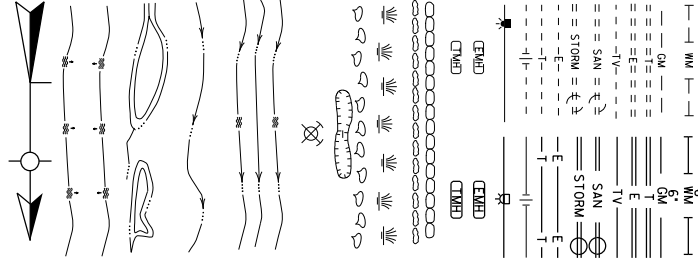

SPECIAL NOTE IIE

SPECIAL NOTE FOR BORING AND JACKING STEEL PIPE WITHOUT CARRIER PIPE

GENERAL & SPECIAL NOTES

THE CONTRACTOR IS INSTRUCTED TO CALL 1-800-752-6007 TO REACH KY 811, THE ONE-CALL SYSTEM FOR INFORMATION ON THE LOCATION OF EXISTING UNDERGROUND UTILITIES. THE CALL IS TO BE PLACED A MINIMUM OF TWO (2) DAYS AND NO MORE THAN TEN (10) BUSINESS DAYS PRIOR TO EXCAVATION. THE CONTRACTOR SHOULD BE AWARE THAT OWNERS OF UNDERGROUND UTILITIES ARE NOT REQUIRED TO BE MEMBERS OF THE KY 811 ONE-CALL BEFORE-DIG (BDU) SERVICE. THE CONTRACTOR MUST COORDINATE EXCAVATION WITH THE UTILITY OWNERS, INCLUDING THOSE WHOM DO NOT SUBSCRIBE TO KY 811. IT MAY BE NECESSARY FOR THE CONTRACTOR TO CONTACT THE COUNTY COURT CLERK TO DETERMINE WHAT UTILITY COMPANIES HAVE FACILITIES IN THE AREA.

LEGEND WITH NOTES

COUNTY OF	ITEM NO.	SHEET NO.
PIKE	12-348.00	R3

COORDINATE CONTROL

Point	Description	Northing	Easting	Elevation
C.P. 1	Nail	369529.99	586580.170	1149.930
C.P. 2	Nail	369585.488	586537.41	694.56
C.P. 3	Nail	369599.56	586585.408	697.46

BASIS OF ELEVATIONS
Elevations were derived from GPS methods and are adjusted to the NAVD88 Vertical Datum. Geoid model used was Geoid12A.
COORDINATE SYSTEM

Coordinates for horizontal control were obtained from GPS methods and adjusted to the National NAD83/FBN System.
Coordinates are based on State Plane Coordinate System Single Zone and in U.S. Survey Feet.

PIPE CENTERLINE DATA

Point	Description	Northing	Easting	Station
POB	Proposed Pipe	369586.91	586596.17	9+29.94
PI	Proposed Pipe	369587.18	586588.41	10+19.94
PI	Proposed Pipe	369597.69	586579.72	12+07.36
PI	Proposed Pipe	369588.05	586542.13	14+62.20
PI	Proposed Pipe	369573.81	586534.17	14+91.64
POE	Proposed Pipe	369569.64	586543.87	15+42.12

Note: From approx. Sta. 12+07 to Sta. 14+17, coordinate grading over the proposed pipe with the property owner.

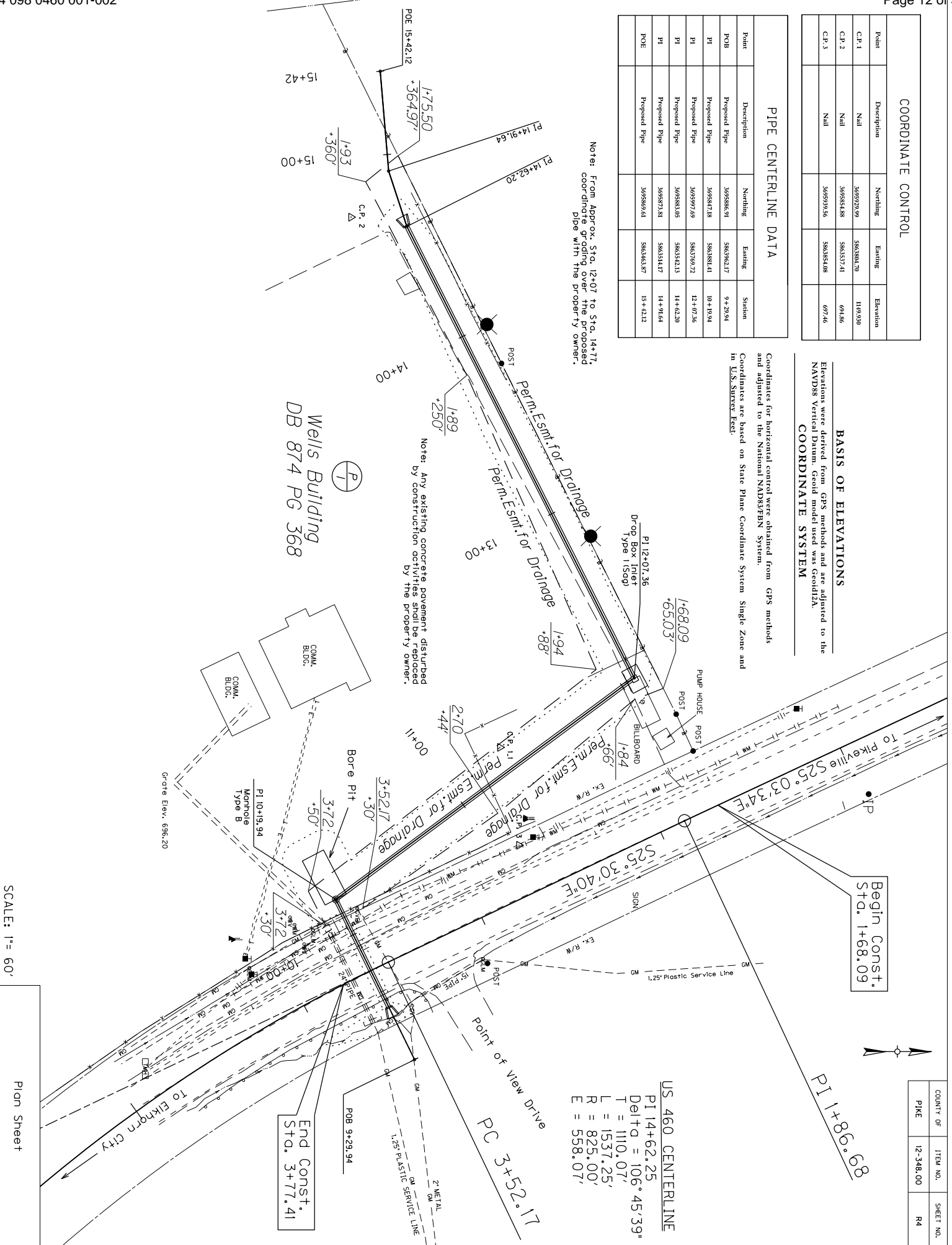

Note: Any existing concrete pavement disturbed by construction activities shall be replaced by the property owner.

Begin Const. Sta. 1+68.09

End Const. Sta. 3+77.41

US 460 CENTERLINE
PI 14+62.25
Delta = 106° 45' 39"
T = 1110.07'
L = 1537.25'
R = 825.00'
E = 558.07'

SCALE: 1" = 60'

Plan Sheet

COUNTY OF	ITEM NO.	SHEET NO.
PIKE	12-348.00	R4

COUNTY OF	ITEM NO.	SHEET NO.
PIKE	12-348.00	R5

Construct 24" Pipe
Culvert Headwall
with 10 Cu. Yds. of
Class II Channel Lining

Construct Manhole
Type B
RE = 697.13'

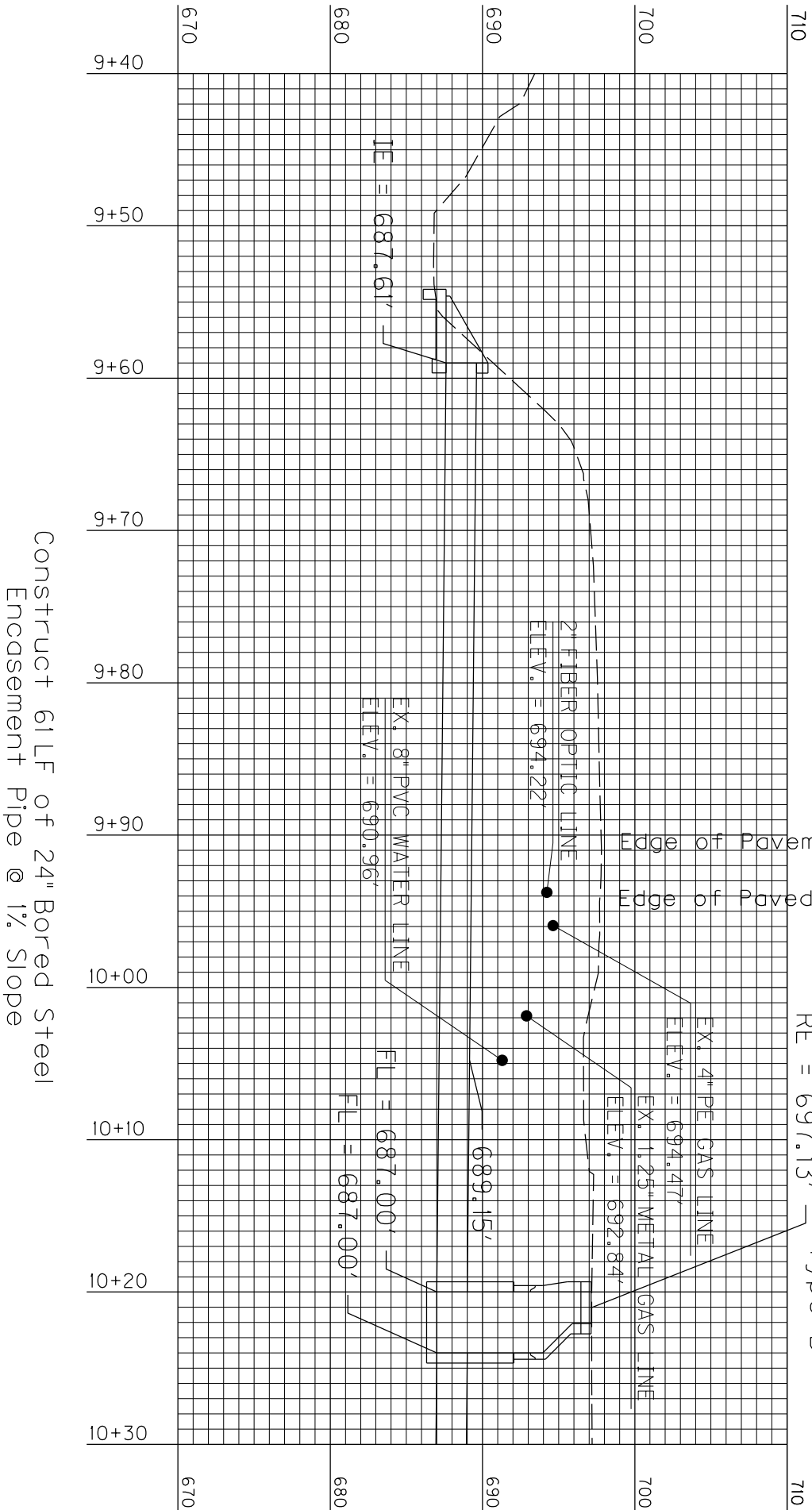

Construct 61 LF of 24" Bored Steel
Encasement Pipe @ 1% Slope

SCALE: 1" = 10'

Pipe Sheet 1 of 3

COUNTY OF	ITEM NO.	SHEET NO.
PIKE	12-348.00	R6

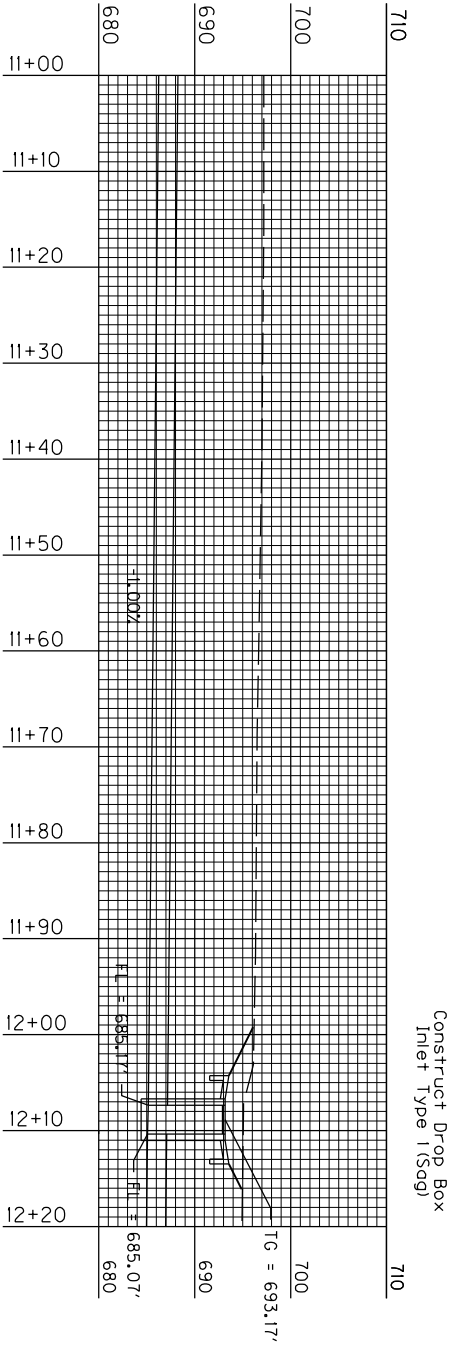
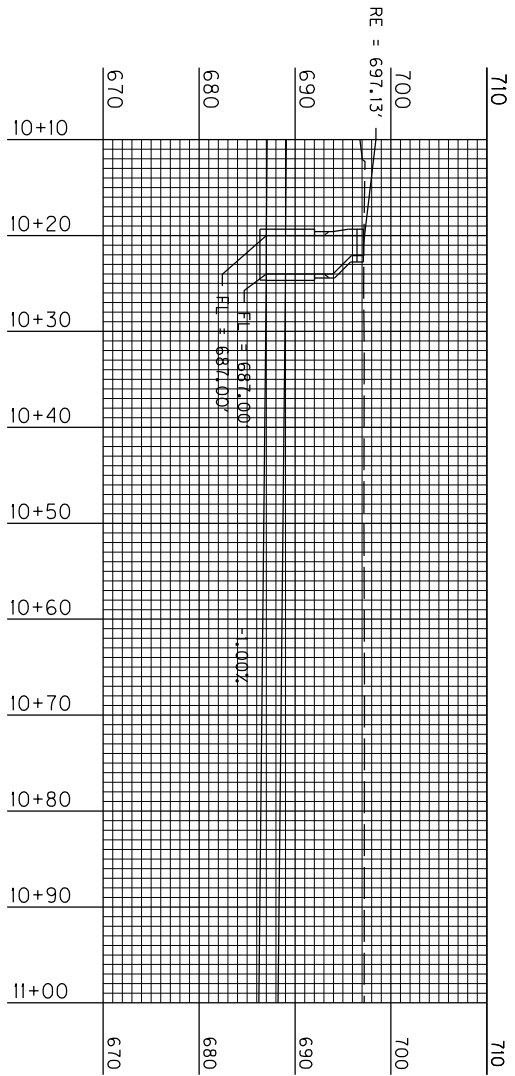

Construct 183.4 LF of 24" Thermoplastic
Pipe (no alternate) @ 1/2" Slope
with 326 sq. Yds. of Geotextile Fabric Type IV
for Pipe and 22 cubic yards of Flowable Fill

SCALE: 1" = 20'

Pipe Sheet 2 of 3

COUNTY OF	ITEM NO.	SHEET NO.
PIKE	12-348.00	R7

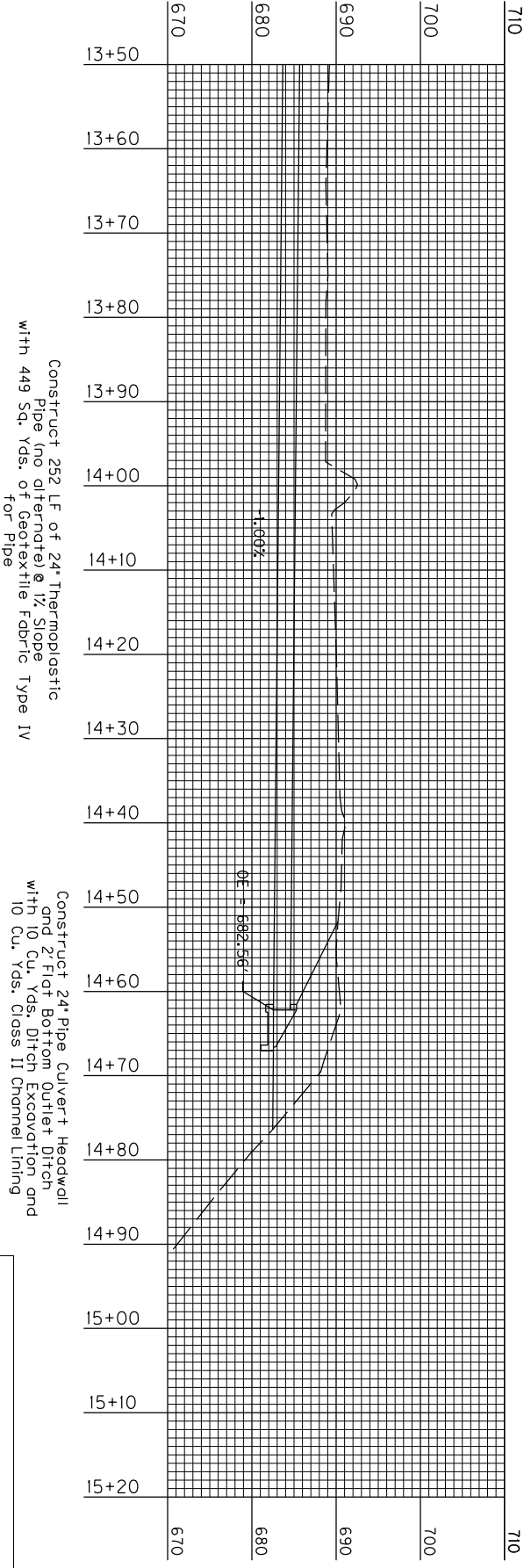
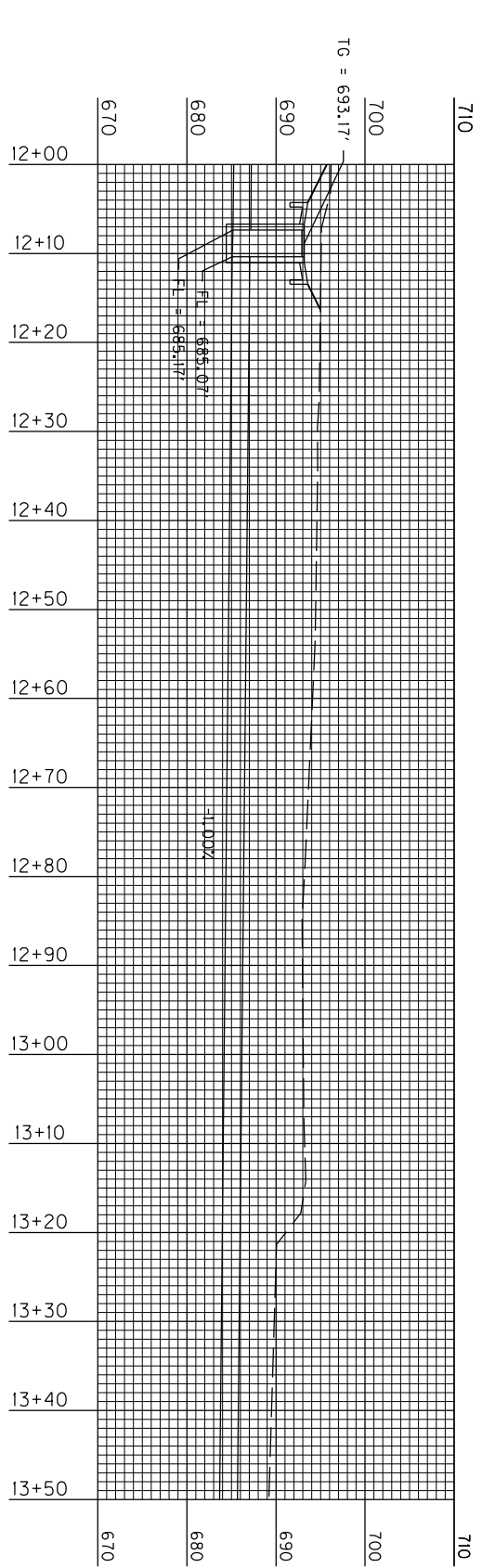

Construct 252 LF of 24" Thermoplastic Pipe (no alternate) @ 1/2" Slope with 449 Sq. Yds. of Geotextile Fabric Type IV for Pipe

Construct 24" Pipe Culvert Headwall and 2 Flat Bottom Outlet Ditch with 10 Cu. Yds. Ditch Excavation and 10 Cu. Yds. Class II Channel Lining

SCALE: 1" = 20'

Pipe Sheet 3 of 3

COUNTY OF	ITEM NO.	SHEET NO.
PIKE	12-348.00	R8

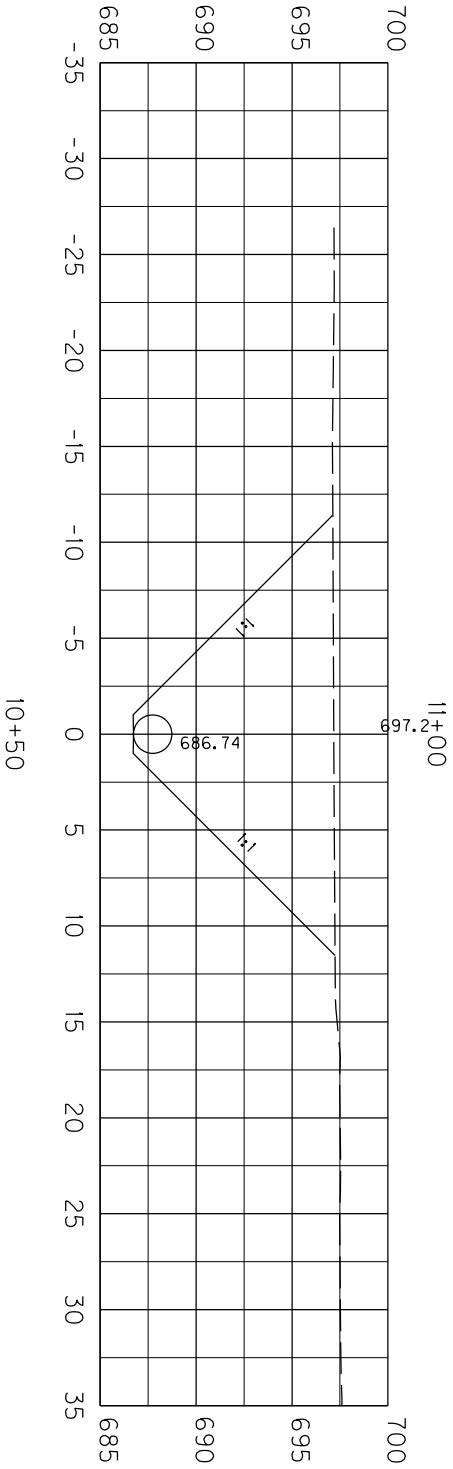
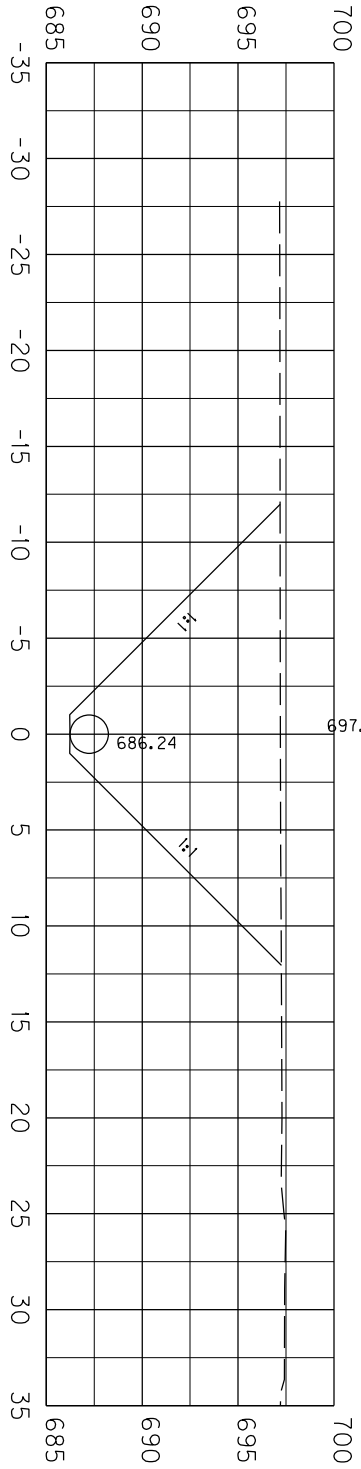
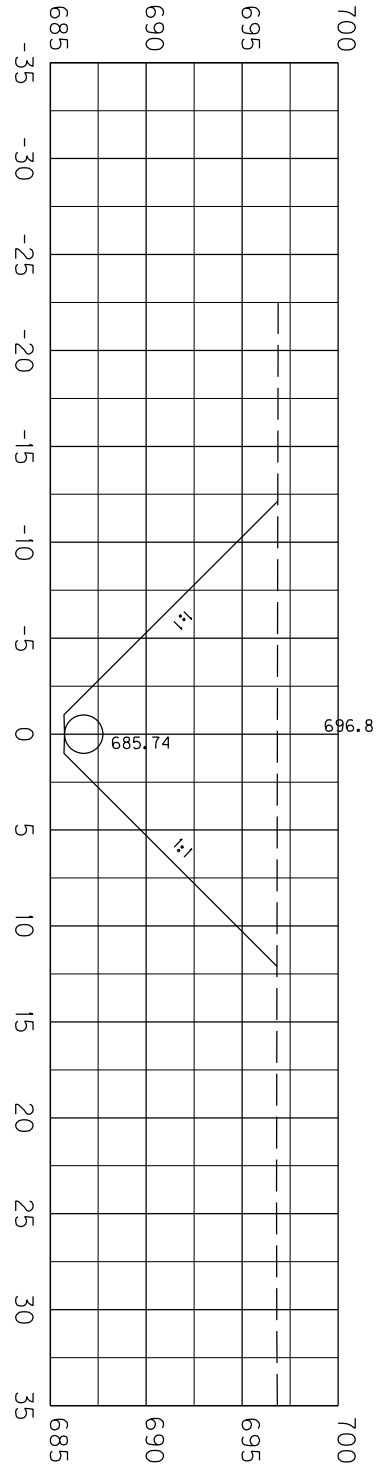

SCALE: 1" = 10'

Pipe Trench Sheet 1 of 3

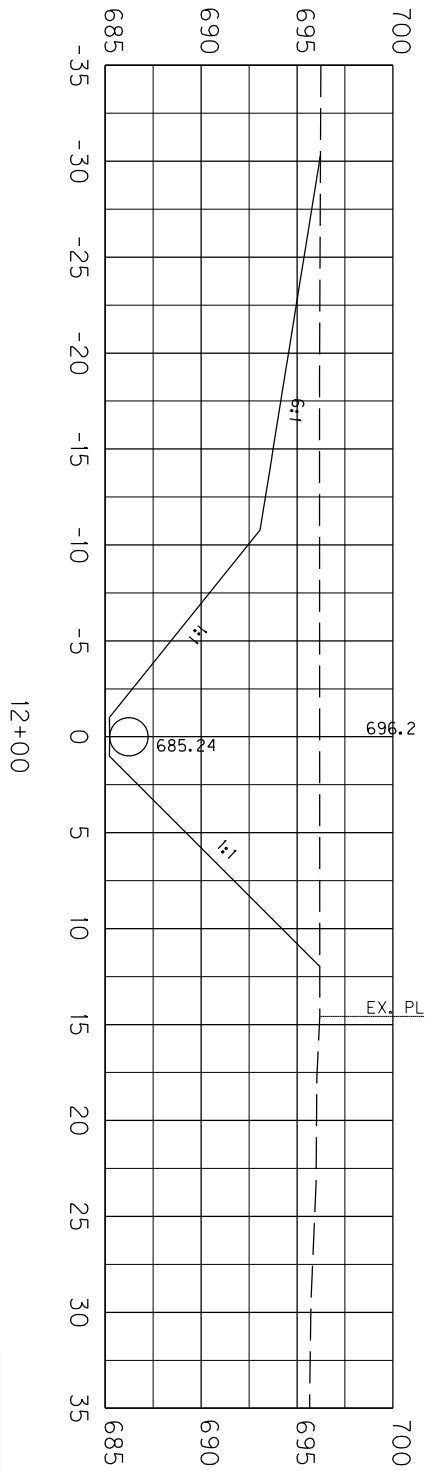
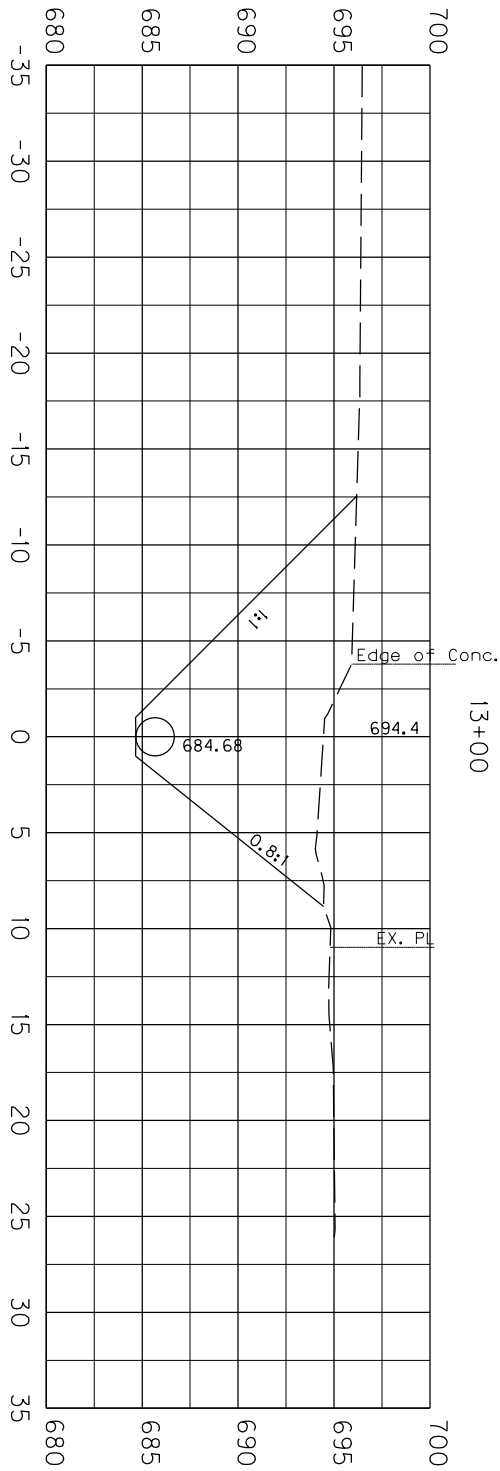
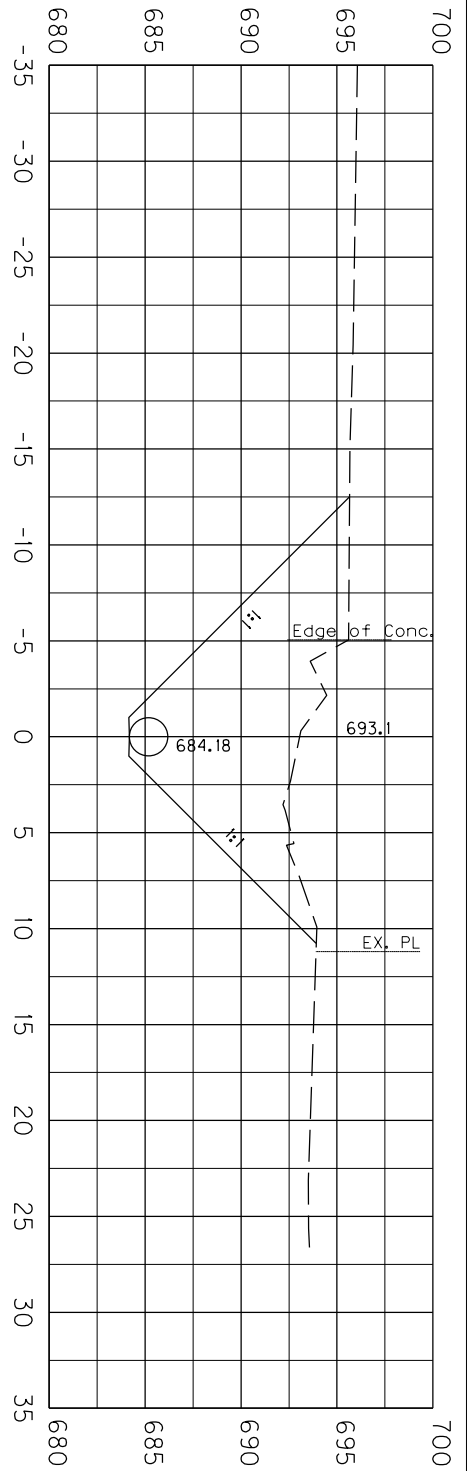

SCALE: 1" = 10'

Pipe Trench Sheet 2 of 3

COUNTY OF	ITEM NO.	SHEET NO.
PIKE	12-348.00	R9

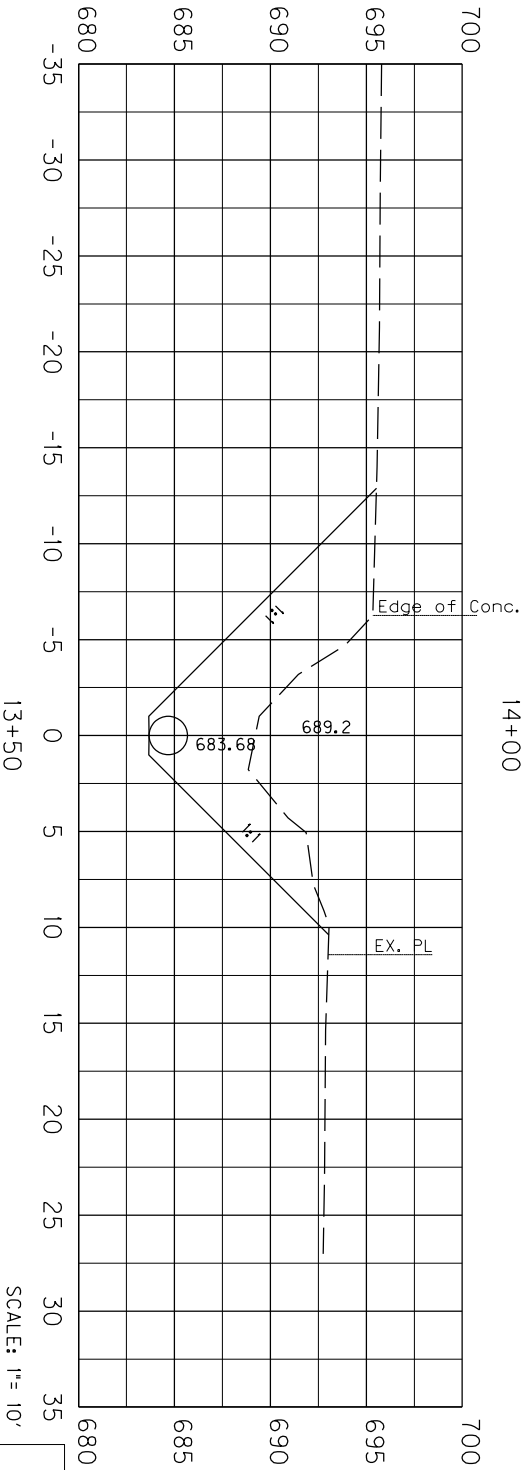
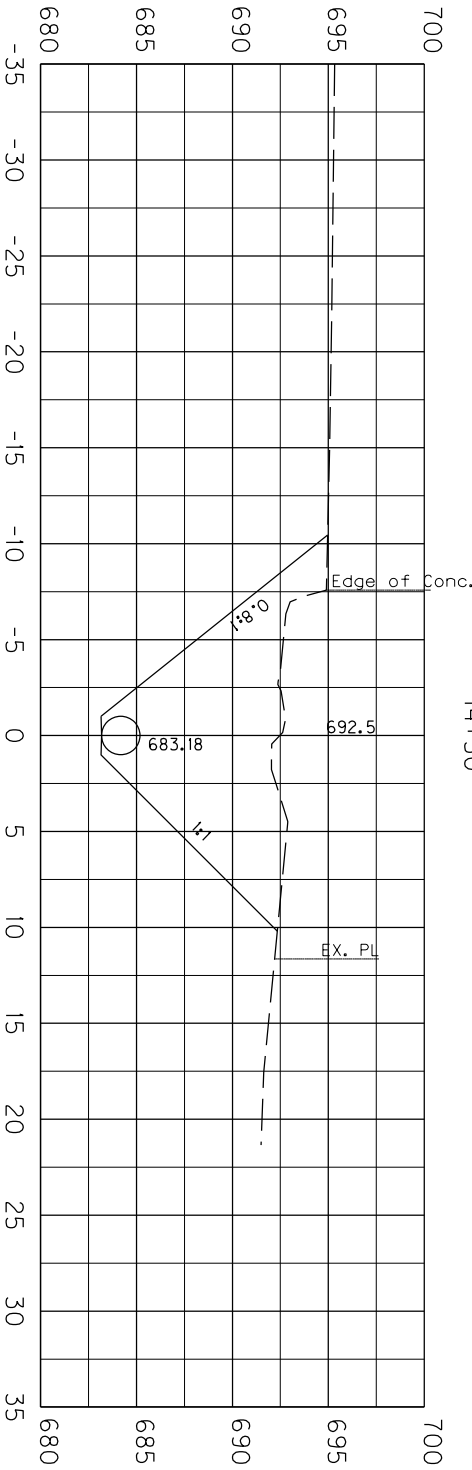
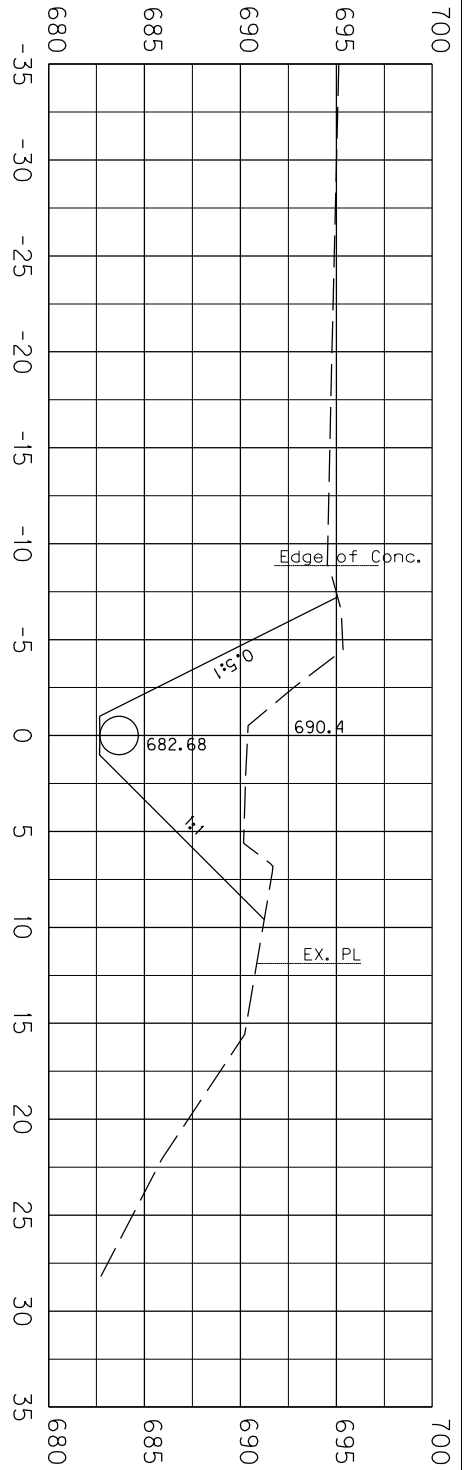

SCALE: 1" = 10'

Pipe Trench Sheet 3 of 3

COUNTY OF	ITEM NO.	SHEET NO.
PIKE	12-348.00	R10



KENTUCKY TRANSPORTATION CABINET
Department of Highways
DIVISION OF RIGHT OF WAY & UTILITIES

RIGHT OF WAY CERTIFICATION

TC 62-226
Rev. 01/2016
Page 1 of 1

<input checked="" type="checkbox"/>	Original	<input type="checkbox"/>	Re-Certification	RIGHT OF WAY CERTIFICATION
-------------------------------------	-----------------	--------------------------	-------------------------	-----------------------------------

ITEM #	COUNTY	PROJECT # (STATE)	PROJECT # (FEDERAL)
12-348.00	Pike	FD04 098 95 102 01C	

PROJECT DESCRIPTION

US 460 Drainage Improvement

No Additional Right of Way Required

Construction will be within the limits of the existing right of way. The right of way was acquired in accordance to FHWA regulations under the Uniform Relocation Assistance and Real Property Acquisitions Policy Act of 1970, as amended. No additional right of way or relocation assistance were required for this project.

Condition # 1 (Additional Right of Way Required and Cleared)

All necessary right of way, including control of access rights when applicable, have been acquired including legal and physical possession. Trial or appeal of cases may be pending in court but legal possession has been obtained. There may be some improvements remaining on the right-of-way, but all occupants have vacated the lands and improvements, and KYTC has physical possession and the rights to remove, salvage, or demolish all improvements and enter on all land. Just Compensation has been paid or deposited with the court. All relocations have been relocated to decent, safe, and sanitary housing or that KYTC has made available to displaced persons adequate replacement housing in accordance with the provisions of the current FHWA directive.

Condition # 2 (Additional Right of Way Required with Exception)

The right of way has not been fully acquired, the right to occupy and to use all rights-of-way required for the proper execution of the project has been acquired. Some parcels may be pending in court and on other parcels full legal possession has not been obtained, but right of entry has been obtained, the occupants of all lands and improvements have vacated, and KYTC has physical possession and right to remove, salvage, or demolish all improvements. Just Compensation has been paid or deposited with the court for most parcels. Just Compensation for all pending parcels will be paid or deposited with the court prior to AWARD of construction contract

Condition # 3 (Additional Right of Way Required with Exception)

The acquisition or right of occupancy and use of a few remaining parcels are not complete and/or some parcels still have occupants. All remaining occupants have had replacement housing made available to them in accordance with 49 CFR 24.204. KYTC is hereby requesting authorization to advertise this project for bids and to proceed with bid letting even though the necessary right of way will not be fully acquired, and/or some occupants will not be relocated, and/or the just compensation will not be paid or deposited with the court for some parcels until after bid letting. KYTC will fully meet all the requirements outlined in 23 CFR 635.309(c)(3) and 49 CFR 24.102(j) and will expedite completion of all acquisitions, relocations, and full payments after bid letting and prior to AWARD of the construction contract or force account construction.

Total Number of Parcels on Project	1	EXCEPTION (S) Parcel #	ANTICIPATED DATE OF POSSESSION WITH EXPLANATION
Number of Parcels That Have Been Acquired			
Signed Deed	1		Consent&Releas signed - Deed to be signed at later date.
Condemnation	0		
Signed ROE	0		

Notes/ Comments (Use Additional Sheet if necessary)

Property Owner signed consent and release to allow work to proceed. Deed to be signed for continued maintenance at a later date. Parcel to be donated through deed.

LPA RW Project Manager		Right of Way Supervisor	
Printed Name		Printed Name	Joe Tackett
Signature		Signature	<i>Joe Tackett</i>
Date		Date	4-25-2019
Right of Way Director		FHWA	
Printed Name		Printed Name	
Signature		Signature	
Date		Date	



KENTUCKY TRANSPORTATION CABINET
Department of Highways
DIVISION OF RIGHT OF WAY & UTILITIES

TC 62-226
Rev. 01/2016
Page 2 of 1

RIGHT OF WAY CERTIFICATION

UTILITIES AND RAIL CERTIFICATION NOTE

Pike County
**Reconstruct the Existing Drainage System Under US 460 Between MP 1.15 to 1.20 to Eliminate
Drainage Water Flooding US 460 Roadway**
ITEM NUMBER: 12-348.00

PROJECT NOTES ON UTILITIES

Please Note: The information presented in this Utility Note is informational in nature and the information contained herein is not guaranteed.

The contractor will be responsible for contacting all utility facility owners on the subject project to coordinate his activities. The contractor will coordinate his activities to minimize and, where possible, avoid conflicts with utility facilities. Due to the nature of the work proposed, it is unlikely to conflict with the existing utilities beyond minor facility adjustments. Where conflicts with utility facilities are unavoidable, the contractor will coordinate any necessary relocation work with the facility owner and Resident Engineer. The Kentucky Transportation Cabinet maintains the right to remove or alter portions of this contract if a utility conflict occurs. The utility facilities as noted in the previous section(s) have been determined using data garnered by varied means and with varying degrees of accuracy: from the facility owners, a result of S.U.E., field inspections, and/or reviews of record drawings. The facilities defined may not be inclusive of all utilities in the project scope and are not Level A quality, unless specified as such. It is the contractor's responsibility to verify all utilities and their respective locations before excavating.

The contractor shall make every effort to protect underground facilities from damage as prescribed in the Underground Facility Damage Protection Act of 1994, Kentucky Revised Statute KRS 367.4901 to 367.4917. It is the contractor's responsibility to determine and take steps necessary to be in compliance with federal and state damage prevention directives. The contractor is instructed to contact KY 811 for the location of existing underground utilities. Contact shall be made a minimum of two (2) and no more than ten (10) business days prior to excavation. The contractor shall submit Excavation Locate Requests to the Kentucky Contact Center (KY 811) via web ticket entry. The submission of this request does not relieve the contractor from the responsibility of contacting non-member facility owners, whom are to be contacted through their individual Protection Notification Center. It may be necessary for the contractor to contact the County Court Clerk to determine what utility companies have facilities in the area. Non-compliance with these directives can result in the enforcement of penalties.

UTILITIES AND RAIL CERTIFICATION NOTE

Pike County
**Reconstruct the Existing Drainage System Under US 460 Between MP 1.15 to 1.20 to Eliminate
Drainage Water Flooding US 460 Roadway**
ITEM NUMBER: 12-348.00

NOTE: DO NOT DISTURB THE FOLLOWING FACILITIES LOCATED WITHIN THE PROJECT DISTURB LIMITS

AT&T - KY – Underground and above ground facilities

Kentucky Power Company – Above ground facilities.

Suddenlink Communications – Above ground facilities

Mountain Water District – Water facilities

City Of Pikeville - Underground Gas Line Facilities

Lindsey Enterprise Inc. - Underground Gas Line Facilities – (See Note Below)

The contractor shall arrange an on-site meeting with AT&T KY, City of Pikeville and Mountain Water District to determine all elevations are correct. This meeting shall be held prior to any excavation on bore pit is started.

Lindsey Enterprises, Inc. – Underground Gas Line Facilities. – Lindsey Enterprises have two gas service lines located at inlet end of existing cross drains. These lines go through existing drains, under US 23, one then serves a private residence and one is mainline line which goes across river. The contractor shall arrange an on-site meeting with Lindsey Enterprise and resident engineer to discuss if these lines can be temporarily moved during construction of the new cross drain.

The Contractor is fully responsible for protection of all utilities listed above

**THE FOLLOWING FACILITY OWNERS ARE RELOCATING/ADJUSTING THEIR FACILITIES WITHIN THE
PROJECT LIMITS AND WILL BE COMPLETE PRIOR TO CONSTRUCTION**

N/A

UTILITIES AND RAIL CERTIFICATION NOTE

Pike County
Reconstruct the Existing Drainage System Under US 460 Between MP 1.15 to 1.20 to Eliminate
Drainage Water Flooding US 460 Roadway
ITEM NUMBER: 12-348.00

THE FOLLOWING FACILITY OWNERS HAVE FACILITIES TO BE RELOCATED/ADJUSTED BY THE OWNER OR THEIR SUBCONTRACTOR AND IS TO BE COORDINATED WITH THE ROAD CONTRACT

N/A

THE FOLLOWING FACILITY OWNERS HAVE FACILITIES TO BE RELOCATED/ADJUSTED BY THE ROAD CONTRACTOR AS INCLUDED IN THIS CONTRACT

N/A

RAIL COMPANIES HAVE FACILITIES IN CONJUNCTION WITH THIS PROJECT AS NOTED

No Rail Involvement **Rail Involved** **Rail Adjacent**

AREA FACILITY OWNER CONTACT LIST

Facility Owner	Address	Contact Name	Phone	Email
AT&T - KY - Communication	29 Willis Branch Prestonsburg KY 41653	Jack Salyer	6064249328	js2299@att.com
City of Pikeville - Gas	215 N Main Cross St Louisa KY 41230	Harold Slone	606638-4038	mayoroflouisa@gmail.com
Lindsey Enterprises, Inc.	PO Box 902 Pikeville, KY 40501	Will Lindsey	606-437-4386	willlindsey@hotmail.com
Mountain Water District	PO Box 3157, Pikeville, KY 41502	Roy Sawyers	606-631-6165	rsawyers@mtwater.org
KY Power Company	3249 North Mayo Trail, Pikeville, KY 41501	Bill Johnson	606-437-3823	wmjohnson@aep.com
Suddenlink Communications	PO 1220, 4038 Teays Valley Road, Scott Depot, WV 25560-1220	Rusty Pauley	304-654-1137	Franklin.pauley@suddenlink.com

PART II
SPECIFICATIONS AND STANDARD DRAWINGS

SPECIFICATIONS REFERENCE

Any reference in the plans or proposal to previous editions of the *Standard Specifications for Road and Bridge Construction* and *Standard Drawings* are superseded by *Standard Specifications for Road and Bridge Construction, Edition of 2012* and *Standard Drawings, Edition of 2016*.

SUPPLEMENTAL SPECIFICATIONS

The contractor shall use the Supplemental Specifications that are effective at the time of letting.
The Supplemental Specifications can be found at the following link:

<http://transportation.ky.gov/Construction/Pages/Kentucky-Standard-Specifications.aspx>

11E

**SPECIAL NOTE FOR BORING AND JACKING STEEL PIPE
 WITHOUT CARRIER PIPE**

This Special Note will apply where indicated on the plans or in the proposal. Section references herein are to the Department’s 2012 Standard Specifications for Road and Bridge Construction.

1.0 DESCRIPTION. Bore and jack steel pipe. Use this note when no carrier pipe will be encased.

2.0 MATERIALS.

2.1 Pipe. Provide plain end steel pipe with a specific minimum yield strength, SMYS, of at least 35,000 psi and tensile strength of 60,000 psi per API-5L grade B material. The steel pipe supplied shall be manufactured by the seamless, electric-weld, submerged-arc weld or gas metal-arc well process as specified in API –5L. Certification of 35,000 psi SMYS shall be furnished by the supplier through the Contractor to the Engineer to retain 3 copies.

MINIMUM WALL THICKNESS FOR STEEL PIPE	
Nominal Diameter (Inches)	Wall Thickness (Inches)
18 or less	0.375
24	0.500
30	0.500
36	0.532
42	0.625

2.2 Grout. Conform to Subsection 601.03.03.

2.3 High Grade Bentonite. Conform to the following:

API 13A Section 4		
Requirement	Specification	Result
Viscometer Dial Reading at 600 rpm	30, minimum	40
Yield Point/Plastic Viscosity Ratio	3, maximum	3.00 maximum
Filtrate Volume	15 cm ³ , maximum	14.50 maximum
Residue greater than 75 micrometers	4.0 wt percent maximum	1.0-1.5 %
Moisture	10.0 wt percent maximum	9.0-9.5%

3.0 CONSTRUCTION. Perform the following:

1. Locate a suitable pit and obtain the Engineer’s approval.
2. Excavate the pit or trenches for the BORE AND JACK operation and for placing the end joints of pipe, when required. Securely sheet and brace the pits or trenches to prevent caving, where necessary.

11E

3. When installing pipe under railroads, highways, streets, or other facilities by Bore and Jack, perform construction without interfering with the facility operation or weakening the roadbed or structure.
4. Place excavated material near the top of the working pit and dispose of it as required. Use water or other fluids with the boring operation to lubricate the cuttings. Do not perform jetting.
5. In unconsolidated soil formations, use a gel-forming colloidal drilling fluid with at least 10 percent of high grade bentonite to consolidate excavated material, seal the walls of the hole, and lubricate subsequent removal of material and immediate pipe installation.
6. Ensure that the diameter of the excavation conforms to the outside diameter of the pipe as closely as possible.
7. Pressure grout voids that develop during the installation operation and that the Engineer determines are detrimental to the Work.
8. To force the pipe through the roadbed into the bored space, use a jack with a head constructed to apply uniform pressure around the ring of the pipe, which shall be square cut.
9. Set the pipe to be jacked on guides, braced together to properly support the pipe section and to direct it to the proper line and grade.
10. When the installation is made by concurrent boring and jacking, solidly weld all joints. Ensure the weld is strong enough to withstand the forces exerted from the boring and jacking operations as well as the vertical loading imposed on the pipe after installation and that it provides a smooth, non-obstructing joint in the interior of the pipe.
11. When the pipe is installed in open trench, bed and backfill according to Section 701.
12. The line and grade from the pipe's final position, as shown on plans, may vary no more than 2 percent in lateral alignment and one percent in vertical grade. Ensure that the final grade of the flow line is in the direction indicated on the Plans.
13. Use a cutting edge around the head end. Extend it a short distance beyond the pipe end with inside angles or lugs to keep the cutting edge from slipping back into the pipe.
14. Once the pipe installation begins, proceed with the operation without interruption to prevent the pipe from becoming firmly set in the embankment.
15. Remove and replace pipe damaged in jacking operations.
16. After completing the installation, backfill the excavated pits and trenches with flowable fill according to Section 601.03.03 B) 5 a) if the pit is in median area where it will have pavement over it.

4.0 MEASUREMENT. The Department will measure the completed length of Bore and Jacked pipe through the flowline from end to end in linear feet. The Department will not measure pressure grouting voids or removal and replacement of pipe damaged in jacking operations for payment and will consider it incidental to Bore and Jack. When abandoning a bore hole due to mechanical malfunction, improper alignment, or other problems due to construction operations, the Department will not measure the backfill and relocation for payment and will consider it incidental to this item of work. When abandoning a bore hole due to an unforeseen physical obstruction or situation, the Department will measure the work according to a negotiated supplemental agreement.

5.0 PAYMENT. The Department will make payment for the completed and accepted quantities under the following:

11E

<u>Code</u>	<u>Pay Item</u>	<u>Pay Unit</u>
----	Bore and Jack, Size Pipe	Linear Foot

The Department will consider payment as full compensation for all materials, earthwork, shoring, pipe and work required under this section.

June 15, 2012

PART III

EMPLOYMENT, WAGE AND RECORD REQUIREMENTS

**TRANSPORTATION CABINET
DEPARTMENT OF HIGHWAYS**

**LABOR AND WAGE REQUIREMENTS
APPLICABLE TO OTHER THAN FEDERAL-AID SYSTEM PROJECTS**

- I. Application
- II. Nondiscrimination of Employees (KRS 344)

I. APPLICATION

1. These contract provisions shall apply to all work performed on the contract by the contractor with his own organization and with the assistance of workmen under his immediate superintendence and to all work performed on the contract by piecework, station work or by subcontract. The contractor's organization shall be construed to include only workmen employed and paid directly by the contractor and equipment owned or rented by him, with or without operators.

2. The contractor shall insert in each of his subcontracts all of the stipulations contained in these Required Provisions and such other stipulations as may be required.

3. A breach of any of the stipulations contained in these Required Provisions may be grounds for termination of the contract.

3. If the contractor is in control of apprenticeship or other training or retraining, including on-the-job training programs, he shall not discriminate against an individual because of his race, color, religion, national origin, sex, disability or age forty (40) and over, in admission to, or employment in any program established to provide apprenticeship or other training.

4. The contractor will send to each labor union or representative of workers with which he has a collective bargaining agreement or other contract or understanding, a notice to be provided advising the said labor union or workers' representative of the contractor's commitments under this section, and shall post copies of the notice in conspicuous places available to employees and applicants for employment. The contractor will take such action with respect to any subcontract or purchase order as the administrating agency may direct as a means of enforcing such provisions, including sanctions for non-compliance.

Revised: January 25, 2017

II. NONDISCRIMINATION OF EMPLOYEES

**AN ACT OF THE KENTUCKY
GENERAL ASSEMBLY TO PREVENT
DISCRIMINATION IN EMPLOYMENT
KRS CHAPTER 344
EFFECTIVE JUNE 16, 1972**

The contract on this project, in accordance with KRS Chapter 344, provides that during the performance of this contract, the contractor agrees as follows:

1. The contractor shall not fail or refuse to hire, or shall not discharge any individual, or otherwise discriminate against an individual with respect to his compensation, terms, conditions, or privileges of employment, because of such individual's race, color, religion, national origin, sex, disability or age (forty and above); or limit, segregate, or classify his employees in any way which would deprive or tend to deprive an individual of employment opportunities or otherwise adversely affect his status as an employee, because of such individual's race, color, religion, national origin, sex, disability or age forty (40) and over. The contractor agrees to post in conspicuous places, available to employees and applicants for employment, notices to be provided setting forth the provisions of this nondiscrimination clause.

2. The contractor shall not print or publish or cause to be printed or published a notice or advertisement relating to employment by such an employer or membership in or any classification or referral for employment by the employment agency, indicating any preference, limitation, specification, or discrimination, based on race, color, religion, national origin, sex, or age forty (40) and over, or because the person is a qualified individual with a disability, except that such a notice or advertisement may indicate a preference, limitation, or specification based on religion, national origin, sex, or age forty (40) and over, or because the person is a qualified individual with a disability, when religion, national origin, sex, or age forty (40) and over, or because the person is a qualified individual with a disability, is a bona fide occupational qualification for employment.

EXECUTIVE BRANCH CODE OF ETHICS

In the 1992 regular legislative session, the General Assembly passed and Governor Brereton Jones signed Senate Bill 63 (codified as KRS 11A), the Executive Branch Code of Ethics, which states, in part:

KRS 11A.040 (7) provides:

No present or former public servant shall, within six (6) months following termination of his office or employment, accept employment, compensation, or other economic benefit from any person or business that contracts or does business with, or is regulated by, the state in matters in which he was directly involved during the last thirty-six (36) months of his tenure. This provision shall not prohibit an individual from returning to the same business, firm, occupation, or profession in which he was involved prior to taking office or beginning his term of employment, or for which he received, prior to his state employment, a professional degree or license, provided that, for a period of six (6) months, he personally refrains from working on any matter in which he was directly involved during the last thirty-six (36) months of his tenure in state government. This subsection shall not prohibit the performance of ministerial functions, including but not limited to filing tax returns, filing applications for permits or licenses, or filing incorporation papers, nor shall it prohibit the former officer or public servant from receiving public funds disbursed through entitlement programs.

KRS 11A.040 (9) states:

A former public servant shall not represent a person or business before a state agency in a matter in which the former public servant was directly involved during the last thirty-six (36) months of his tenure, for a period of one (1) year after the latter of:

- a) The date of leaving office or termination of employment; or
- b) The date the term of office expires to which the public servant was elected.

This law is intended to promote public confidence in the integrity of state government and to declare as public policy the idea that state employees should view their work as a public trust and not as a way to obtain private benefits.

If you have worked for the executive branch of state government within the past six months, you may be subject to the law's prohibitions. The law's applicability may be different if you hold elected office or are contemplating representation of another before a state agency.

Also, if you are affiliated with a firm which does business with the state and which employs former state executive-branch employees, you should be aware that the law may apply to them.

In case of doubt, the law permits you to request an advisory opinion from the Executive Branch Ethics Commission, 3 Fountain Place, Frankfort, Kentucky 40601; telephone (502) 564-7954.

Revised: January 27, 2017

Kentucky Equal Employment Opportunity Act of 1978

The requirements of the Kentucky Equal Employment Opportunity Act of 1978 (KRS 45.560-45.640) shall apply to this Contract. The apparent low Bidder will be required to submit EEO forms to the Division of Construction Procurement, which will then forward to the Finance and Administration Cabinet for review and approval. No award will become effective until all forms are submitted and EEO/CC has certified compliance. The required EEO forms are as follows:

- EEO-1: Employer Information Report
- Affidavit of Intent to Comply
- Employee Data Sheet
- Subcontractor Report

These forms are available on the Finance and Administration's web page under ***Vendor Information, Standard Attachments and General Terms*** at the following address:
<https://www.eProcurement.ky.gov>.

Bidders currently certified as being in compliance by the Finance and Administration Cabinet may submit a copy of their approval letter in lieu of the referenced EEO forms.

For questions or assistance please contact the Finance and Administration Cabinet by email at **finance.contractcompliance@ky.gov** or by phone at 502-564-2874.

EMPLOYEE RIGHTS UNDER THE FAIR LABOR STANDARDS ACT

THE UNITED STATES DEPARTMENT OF LABOR WAGE AND HOUR DIVISION

FEDERAL MINIMUM WAGE

\$7.25

 PER HOUR

BEGINNING JULY 24, 2009

OVERTIME PAY At least 1½ times your regular rate of pay for all hours worked over 40 in a workweek.

CHILD LABOR An employee must be at least **16** years old to work in most non-farm jobs and at least **18** to work in non-farm jobs declared hazardous by the Secretary of Labor.

Youths **14** and **15** years old may work outside school hours in various non-manufacturing, non-mining, non-hazardous jobs under the following conditions:

No more than

- **3** hours on a school day or **18** hours in a school week;
- **8** hours on a non-school day or **40** hours in a non-school week.

Also, work may not begin before **7 a.m.** or end after **7 p.m.**, except from June 1 through Labor Day, when evening hours are extended to **9 p.m.** Different rules apply in agricultural employment.

TIP CREDIT Employers of “tipped employees” must pay a cash wage of at least \$2.13 per hour if they claim a tip credit against their minimum wage obligation. If an employee’s tips combined with the employer’s cash wage of at least \$2.13 per hour do not equal the minimum hourly wage, the employer must make up the difference. Certain other conditions must also be met.

ENFORCEMENT The Department of Labor may recover back wages either administratively or through court action, for the employees that have been underpaid in violation of the law. Violations may result in civil or criminal action.

Employers may be assessed civil money penalties of up to \$1,100 for each willful or repeated violation of the minimum wage or overtime pay provisions of the law and up to \$11,000 for each employee who is the subject of a violation of the Act’s child labor provisions. In addition, a civil money penalty of up to \$50,000 may be assessed for each child labor violation that causes the death or serious injury of any minor employee, and such assessments may be doubled, up to \$100,000, when the violations are determined to be willful or repeated. The law also prohibits discriminating against or discharging workers who file a complaint or participate in any proceeding under the Act.

ADDITIONAL INFORMATION

- Certain occupations and establishments are exempt from the minimum wage and/or overtime pay provisions.
- Special provisions apply to workers in American Samoa and the Commonwealth of the Northern Mariana Islands.
- Some state laws provide greater employee protections; employers must comply with both.
- The law requires employers to display this poster where employees can readily see it.
- Employees under 20 years of age may be paid \$4.25 per hour during their first 90 consecutive calendar days of employment with an employer.
- Certain full-time students, student learners, apprentices, and workers with disabilities may be paid less than the minimum wage under special certificates issued by the Department of Labor.

For additional information:



1-866-4-USWAGE

(1-866-487-9243) TTY: 1-877-889-5627



WWW.WAGEHOUR.DOL.GOV

PART IV
INSURANCE

INSURANCE

The Contractor shall procure and maintain the following insurance in addition to the insurance required by law:

- 1) Commercial General Liability-Occurrence form – not less than \$2,000,000 General aggregate, \$2,000,000 Products & Completed Aggregate, \$1,000,000 Personal & Advertising, \$1,000,000 each occurrence.
- 2) Automobile Liability- \$1,000,000 per accident
- 3) Employers Liability:
 - a) \$100,000 Each Accident Bodily Injury
 - b) \$500,000 Policy limit Bodily Injury by Disease
 - c) \$100,000 Each Employee Bodily Injury by Disease
- 4) The insurance required above must be evidenced by a Certificate of Insurance and this Certificate of Insurance must contain one of the following statements:
 - a) "policy contains no deductible clauses."
 - b) "policy contains _____ (amount) deductible property damage clause but company will pay claim and collect the deductible from the insured."
- 5) KENTUCKY WORKMEN'S COMPENSATION INSURANCE. The contractor shall furnish evidence of coverage of all his employees or give evidence of self-insurance by submitting a copy of a certificate issued by the Workmen's Compensation Board.

The cost of insurance is incidental to all contract items. All subcontractors must meet the same minimum insurance requirements.

PART V
BID ITEMS

PROPOSAL BID ITEMS

191028

Page 1 of 1

Report Date 5/8/19

Section: 0001 - ROADWAY

LINE	BID CODE	ALT	DESCRIPTION	QUANTITY	UNIT	UNIT PRIC	FP	AMOUNT
0010	02562		TEMPORARY SIGNS	105.00	SQFT		\$	
0020	02650		MAINTAIN & CONTROL TRAFFIC	1.00	LS		\$	
0030	02701		TEMP SILT FENCE	369.00	LF		\$	
0040	02704		SILT TRAP TYPE B	2.00	EACH		\$	
0050	02705		SILT TRAP TYPE C	1.00	EACH		\$	
0060	02707		CLEAN SILT TRAP TYPE B	2.00	EACH		\$	
0070	02708		CLEAN SILT TRAP TYPE C	1.00	EACH		\$	
0080	02726		STAKING	1.00	LS		\$	
0090	05963		INITIAL FERTILIZER	.02	TON		\$	
0100	05964		MAINTENANCE FERTILIZER	.02	TON		\$	
0110	05985		SEEDING AND PROTECTION	239.00	SQYD		\$	
0120	05992		AGRICULTURAL LIMESTONE	.02	TON		\$	

Section: 0002 - DRAINAGE

LINE	BID CODE	ALT	DESCRIPTION	QUANTITY	UNIT	UNIT PRIC	FP	AMOUNT
0130	00524		STORM SEWER PIPE-24 IN	435.40	LF		\$	
0140	01208		PIPE CULVERT HEADWALL-24 IN	2.00	EACH		\$	
0150	01490		DROP BOX INLET TYPE 1	1.00	EACH		\$	
0160	01761		MANHOLE TYPE B	1.00	EACH		\$	
0170	02220		FLOWABLE FILL	22.00	CUYD		\$	
0180	02483		CHANNEL LINING CLASS II	20.00	TON		\$	
0190	02600		FABRIC GEOTEXTILE TY IV FOR PIPE	775.00	SQYD	\$2.00	\$	\$1,550.00
0200	20597EC		DITCH EXCAVATION	10.00	CUYD		\$	
0210	21799EN		BORE AND JACK PIPE-24 IN	61.00	LF		\$	

Section: 0003 - DEMOBILIZATION &/OR MOBILIZATION

LINE	BID CODE	ALT	DESCRIPTION	QUANTITY	UNIT	UNIT PRIC	FP	AMOUNT
0220	02569		DEMOBILIZATION	1.00	LS		\$	