



**CALL NO. 326**

**CONTRACT ID. 192970**

**FRANKLIN COUNTY**

**FED/STATE PROJECT NUMBER FE02 037 0060 B00016N 07.92**

**DESCRIPTION FRANKLIN COUNTY BRIDGE 037B00016N**

**WORK TYPE BRIDGE PAINTING & CLEANING**

**PRIMARY COMPLETION DATE 11/15/2019**

**LETTING DATE: May 24,2019**

Sealed Bids will be received electronically through the Bid Express bidding service until 10:00 AM EASTERN DAYLIGHT TIME May 24,2019. Bids will be publicly announced at 10:00 AM EASTERN DAYLIGHT TIME.

**NO PLANS ASSOCIATED WITH THIS PROJECT.**

**REQUIRED BID PROPOSAL GUARANTY:** Not less than 5% of the total bid.

## TABLE OF CONTENTS

PART I	SCOPE OF WORK
	<ul style="list-style-type: none"><li>• PROJECT(S), COMPLETION DATE(S), &amp; LIQUIDATED DAMAGES</li><li>• CONTRACT NOTES</li><li>• STATE CONTRACT NOTES</li><li>• SPECIAL NOTE(S) APPLICABLE TO PROJECT</li></ul>
PART II	SPECIFICATIONS AND STANDARD DRAWINGS
	<ul style="list-style-type: none"><li>• SPECIFICATIONS REFERENCE</li><li>• SUPPLEMENTAL SPECIFICATION</li></ul>
PART III	EMPLOYMENT, WAGE AND RECORD REQUIREMENTS
	<ul style="list-style-type: none"><li>• LABOR AND WAGE REQUIREMENTS</li><li>• EXECUTIVE BRANCH CODE OF ETHICS</li><li>• KENTUCKY EQUAL EMPLOYMENT OPPORTUNITY ACT OF 1978 LOCALITY / STATE</li><li>• PROJECT WAGE RATES / STATE</li></ul>
PART IV	INSURANCE
PART V	BID ITEMS

**PART I**  
**SCOPE OF WORK**

## ADMINISTRATIVE DISTRICT - 05

**CONTRACT ID - 192970**

**FE02 037 0060 B00016N 07.92**

**COUNTY - FRANKLIN**

**PCN - MB03700601901**

**FD04 037 0060 B00016N 07.92**

FRANKLIN COUNTY 037B00016N LOUISVILLE ROAD MP 07.29  
US60 OVER LAYFETTE DRIVE BRIDGE DECK RESTORATION & WATERPROOFING  
GEOGRAPHIC COORDINATES LATITUDE 36:11:11.00 LONGITUDE 84:52:47.00

**COMPLETION DATE(S):**

COMPLETED BY 11/15/2019

APPLIES TO ENTIRE CONTRACT

## **CONTRACT NOTES**

### **PROPOSAL ADDENDA**

All addenda to this proposal must be applied when calculating bid and certified in the bid packet submitted to the Kentucky Department of Highways. Failure to use the correct and most recent addenda may result in the bid being rejected.

### **BID SUBMITTAL**

Bidder must use the Department's electronic bidding software. The Bidder must download the bid file located on the Bid Express website ([www.bidx.com](http://www.bidx.com)) to prepare a bid packet for submission to the Department. The bidder must submit electronically using Bid Express.

### **JOINT VENTURE BIDDING**

Joint venture bidding is permissible. All companies in the joint venture must be prequalified in one of the work types in the Qualifications for Bidders for the project. The bidders must get a vendor ID for the joint venture from the Division of Construction Procurement and register the joint venture as a bidder on the project. Also, the joint venture must obtain a digital ID from Bid Express to submit a bid. A joint bid bond of 5% may be submitted for both companies or each company may submit a separate bond of 5%.

### **UNDERGROUND FACILITY DAMAGE PROTECTION**

The contractor shall make every effort to protect underground facilities from damage as prescribed in the Underground Facility Damage Protection Act of 1994, Kentucky Revised Statute KRS 367.4901 to 367.4917. It is the contractor's responsibility to determine and take steps necessary to be in compliance with federal and state damage prevention directives. When prescribed in said directives, the contractor shall submit Excavation Locate Requests to the Kentucky Contact Center (KY811) via web ticket entry. The submission of this request does not relieve the contractor from the responsibility of contacting non-member facility owners, whom shall be contacted through their individual Protection Notification Center. Non-compliance with these directives can result in the enforcement of penalties.

### **REGISTRATION WITH THE SECRETARY OF STATE BY A FOREIGN ENTITY**

Pursuant to KRS 176.085(1)(b), an agency, department, office, or political subdivision of the Commonwealth of Kentucky shall not award a state contract to a person that is a foreign entity required by [KRS 14A.9-010](#) to obtain a certificate of authority to transact business in the Commonwealth ("certificate") from the Secretary of State under [KRS 14A.9-030](#) unless the person produces the certificate within fourteen (14) days of the bid or proposal opening. If the foreign entity is not required to obtain a certificate as provided in [KRS 14A.9-010](#), the foreign entity should identify the applicable exception. Foreign entity is defined within [KRS 14A.1-070](#).

**For all foreign entities required to obtain a certificate of authority to transact business in the Commonwealth, if a copy of the certificate is not received by the contracting agency within the time frame identified above, the foreign entity's solicitation response shall be deemed non-responsive or the awarded contract shall be cancelled.**

Businesses can register with the Secretary of State at <https://secure.kentucky.gov/sos/ftbr/welcome.aspx>.

### **SPECIAL NOTE FOR PROJECT QUESTIONS DURING ADVERTISEMENT**

Questions about projects during the advertisement should be submitted in writing to the Division of Construction Procurement. This may be done by fax (502) 564-7299 or email to [kytc.projectquestions@ky.gov](mailto:kytc.projectquestions@ky.gov). The Department will attempt to answer all submitted questions. The Department reserves the right not to answer if the question is not pertinent or does not aid in clarifying the project intent.

The deadline for posting answers will be 3:00 pm Eastern Daylight Time, the day preceding the Letting. Questions may be submitted until this deadline with the understanding that the later a question is submitted, the less likely an answer will be able to be provided.

The questions and answers will be posted for each Letting under the heading "Questions & Answers" on the Construction Procurement website ([www.transportation.ky.gov/contract](http://www.transportation.ky.gov/contract)). The answers provided shall be considered part of this Special Note and, in case of a discrepancy, will govern over all other bidding documents.

### **HARDWOOD REMOVAL RESTRICTIONS**

The US Department of Agriculture has imposed a quarantine in Kentucky and several surrounding states, to prevent the spread of an invasive insect, the emerald ash borer. Hardwood cut in conjunction with the project may not be removed from the state. Chipping or burning on site is the preferred method of disposal.

### **INSTRUCTIONS FOR EXCESS MATERIAL SITES AND BORROW SITES**

Identification of excess material sites and borrow sites shall be the responsibility of the Contractor. The Contractor shall be responsible for compliance with all applicable state and federal laws and may wish to consult with the US Fish and Wildlife Service to seek protection under Section 10 of the Endangered Species Act for these activities.

### **ACCESS TO RECORDS**

The contractor, as defined in KRS 45A.030 (9) agrees that the contracting agency, the Finance and Administration Cabinet, the Auditor of Public Accounts, and the Legislative Research Commission, or their duly authorized representatives, shall have access to any books, documents, papers, records, or other evidence, which are directly pertinent to this contract for the purpose of financial audit or program review. Records and other prequalification information confidentially

disclosed as part of the bid process shall not be deemed as directly pertinent to the contract and shall be exempt from disclosure as provided in KRS 61.878(1)(c). The contractor also recognizes that any books, documents, papers, records, or other evidence, received during a financial audit or program review shall be subject to the Kentucky Open Records Act, KRS 61.870 to 61.884.

In the event of a dispute between the contractor and the contracting agency, Attorney General, or the Auditor of Public Accounts over documents that are eligible for production and review, the Finance and Administration Cabinet shall review the dispute and issue a determination, in accordance with Secretary's Order 11-004.

April 30, 2018

## **SPECIAL NOTE FOR RECIPROCAL PREFERENCE**

### **RECIPROCAL PREFERENCE TO BE GIVEN BY PUBLIC AGENCIES TO RESIDENT BIDDERS**

By reference, KRS 45A.490 to 45A.494 are incorporated herein and in compliance regarding the bidders residency. Bidders who want to claim resident bidder status should complete the Affidavit for Claiming Resident Bidder Status along with their bid in the electronic bidding software. Submittal of the Affidavit should be done along the bid in Bid Express.

April 30, 2018



**SPECIAL NOTES  
DISTRICT NO. 5  
ASESTHETIC BRIDGE CLEANING AND PAINTING  
FRANKLIN COUNTY  
CID 192970**

**FE02 037 0060 B00016N 07.92**

US 60 over KY 2271 (Layfette Drive)

***Geographic Coordinates***

Latitude – 36° 11' 11.00''

Longitude – 84° 52' 47.00''

**Description**

40'-40'-40'-62'-40'-40'-40'-40' RCDG Spans, Drawing Nos. 07897 and 20786

## **SPECIAL NOTE FOR AESTHETIC BRIDGE CLEANING AND PAINTING**

**1. DESCRIPTION.** Perform all work in accordance with the Kentucky Transportation Cabinet, Department of Highway's Standard Specification for Road and Bridge Construction applicable Supplemental Specifications, Standard Drawings (current editions) this Note and Attached Detailed Drawings. Section references are to the Standard Specifications. This work consists of the following: (1) Furnish all labor, materials, tools, and equipment; (2) All items included in aesthetic bridge cleaning and painting (3) Maintain and control traffic; (4) All other work required for this contract.

**2. SUBMITTALS**

The Contractor shall comply with the submittal requirements detailed in Section 108 of the Standard Specifications for Road and Bridge Construction (Current Edition) and submit the following **written** items to the Project Engineer **14 days** prior to the Pre-Construction Conference:

- A. A detailed Progress of Work Schedule.
- B. Traffic Control Plan.
- C. Manufacturers' recommended Film Thickness and application conditions for the concrete coating system to be used.

**All submittals must be received, accepted and/or approved by the KYTC Engineer prior to beginning any work.**

**3. MATERIALS.**

**A. Wash Water**

Use clean potable water for all pressure washing.

**B. Concrete Coatings and Mural**

Use one of the coatings from the following manufactures:

<b>Manufacture</b>	<b>Prime Coat</b>	<b>Finish Coat</b>
Sherwin Williams	Macropoxy 646	Acrolon 218 HS
PPG	Amberlock 2	Devoe Devflex
Carboline	Carboguard 890	Carbothane 133 HB
Tnemec	Elastogrip 151	EnviroCrete 15

**C. Steel Coatings**

Use a Class IV, Type VI coating system from the Department's Division of Material's approved product list.

### 3. CONSTRUCTION.

#### A. Bridge Cleaning.

All debris shall be removed from the bridge components. See attached detailed drawings for each bridge addressing components having debris removal. Equipment for removing debris from the bridge components shall be determined by the Contractor, subject to the approval of the Engineer. The Contractor shall prevent any debris from entering any body of water, bridge drainage system, or traffic lanes. All debris removed shall be disposed of in a suitable off-site disposal facility. Prior to all cleaning work, the Contractor shall confirm that any bridge drainage system is not blocked by un-removable debris. A blocked drainage system is considered to be one from which debris cannot be removed using the means specified in this note. If the Engineer has been notified, and concurs that the drainage system is blocked prior to performing other cleaning work, then proceed at the direction of the engineer. If the Contractor does not inspect the bridge drainage system and notify the engineer prior to beginning work any blocked drains will be considered to be the result of the Contractor's operations, and all clearing and cleaning of the drainage system shall be done as part of the work of the specification. All vegetation present at areas of the bridge that are to be addressed in this proposal shall be removed as determined by the Engineer. **All cost to complete Debris Removal, and Remove Vegetation shall as specified shall be included in the Lump Sum price for "Bridge Cleaning".**

#### B. Concrete Surface Preparation.

All concrete surfaces to be painted shall be pressure washed. See attached detailed drawings for each bridge addressing components to be pressure washed. All equipment for pressure washing shall be operated at a minimum pressure of up 4,000 psi with 0 degree spinner tip and/or fan tips as determined by the engineer at the working location with a minimum flow rate of 3.5 gal/minute provided that these pressures do not damage any components of the structure. Pressure and flow rates shall be reduced to a level satisfactory to the Engineer should any damage occur due to power washing procedures. Pressure washing shall be operated at distance of approximately six inches from and perpendicular to the surface. All pressure washing wands shall be equipped with a gauge to accurately determine the amount pressure used. Pressure washing of any bridge element will proceed from top of wash area to bottom of wash area. Wash water will not be released to a bridge element previously washed. Perform all pressure washing at temperatures above 40 degrees Fahrenheit. **All cost to complete Pressure Washing as specified shall be included in the Lump Sum price for Lump Sum price for "Bridge Cleaning".**

#### C. Steel Surface Preparation (Steel Parapet Railing)

All rusted areas of the steel parapet railing shall be cleaned to a SSPC SP-11 (Power Tool Cleaning to Bare Metal). All Power tools shall be equipped with vacuum shrouds and fitted with HEPA filters at their air exhausts. Maintain and operate all vacuum shrouded power tools to collect generated debris. All steel surfaces to be painted shall be pressure washed after all rust cleaning is complete. See Concrete Surface Preparation for pressure washing specifications. **All cost to complete Steel Surface Preparation as specified shall be included in the Lump Sum price for Lump Sum price for "Clean and Paint Structural Steel.**

**D. Coatings Application.**

**Concrete:** Apply specified coatings to all surfaces indicated in the attached detailed drawings. Use compressed air to remove any loose debris from the surfaces that are to be coated after power washing.

**Steel:** Apply specified coatings to all surfaces indicated in the attached detailed drawings. Use compressed air to remove any loose debris from the surfaces that are to be coated after power washing. Supply and apply a primer recommended by the manufacture for the selected coating to all areas where rust has been removed.

**Mural:** After all concrete has been cleaned and painted apply coating for the mural in the specified location. The mural will only receive the finish coat. See attached detailed drawings. The Department at the Contractor's request can provide templates for the mural design.

**All coating application shall be executed using brushes, rollers, etc. No spray application will be permitted.**

- E. Paint:** All coatings shall be applied within manufacturers recommended dry film thickness range. Comply with KYTC "Standard Specifications for Road and Bridge Construction" Section 614.03.02 and coatings supplier recommended conditions for application. Allow the surfaces to be coated to dry before any coating is applied. The coating must be applied to a clean and dry surface. All coating application shall be executed using brushes, rollers, etc. No spray application will be permitted. The Department requires acceptance testing of samples obtained on a per-lot basis per-shipment. The Division of Materials shall perform acceptance testing. Test samples shall be taken at the Contractor's paint storage site. Department personnel shall perform sampling. Allow (10) working days for testing and approval of the sampled paint. It is the Contractor's responsibility to maintain an adequate inventory of approved paint. The Department shall assume no responsibility for lost work due to rejection of paint or approved paint subsequently found to be defective during the application process. Perform all concrete coating application at temperatures above 40 degrees Fahrenheit or in accordance with manufactures specifications.

**The finish coat shall be shall meet the following values.**

**Blue  $L^* = 66.56$   $a^* = -7.26$   $b^* = -20.10$**

All concrete surfaces.

**White  $L^* = 74.94$   $a^* = -1.54$   $b^* = 3.92$**

Steel Railing surfaces.

All cost to complete Concrete Coating Application as specified shall be included in the Lump Sum price for "Concrete Coatings".

All cost to complete Steel Coating Application as specified shall be included in the Lump Sum price for "Clean and Paint Structural Steel".

All cost to complete Mural Coating Application as specified shall be included in the Lump Sum price for "Paint Mural".

**Approximate square footage coatings applied:**

80,000 Square Feet ~ Concrete

2,500 Square Feet ~ Steel

**The square footage listed is for informational purposes only.**

**F. Sequence of Work.**

Complete work in the sequence listed below:

1. Bridge Cleaning
2. Concrete and Steel Surface Preparation
3. Pressure Washing
4. Concrete Coating and Steel Application
5. Mural Application

**G. Access.**

The Contractor shall provide OSHA compliant safe access for all work and inspection. Cost to furnish all items for access shall be considered incidental to the contract.

**H. Inspection.**

The Cabinet will provide inspection for all items required in this contract. Visual inspection will be required upon completion of each work item for each structure component or at the discretion of the Engineer at any time. All visual inspection shall be performed within arm's length distance.

1. **Debris Removal:** Visual Inspection.
2. **Power Washing:** Visual Inspection.
3. **Steel Surface Preparation:** Visual Inspection.

4. **Concrete Coating and Steel Coating:**

Prime Coat Application Check for dry film thickness\*, and defects in paint  
Finish Coat Application Check for dry film thickness\*, paint appearance,  
color and quality of application.

\*Destructive DFTs shall be used. Contractor shall repair all test locations,  
cost will be considered incidental to the contract.

**I. Verifying Field Conditions.**

The Contractor shall be familiar with all conditions at the site. The Cabinet will not consider any claims due to the Contractor having not familiarized themselves with requirements of this work.

**J. Residual Lead.**

Residual lead paint may still be on bridge. The Contractor is advised to take all necessary protective measures including worker safety and environmental regulations when performing surface preparation. The Department will not consider any claims based on residual lead paint.

**K. Damage to the Structure.**

The Contractor shall bear all responsibility and expense for any and all damage to the structure during the repair work, even to the removal and replacement of a fallen span, should the fallen span result from the Contractors actions.

**4. MEASUREMENT.**

**Bridge Cleaning**

**Concrete Coating**

**Clean and Paint Structural Steel**

**Paint Mural**

The Cabinet will measure these items by Lump Sum, completed and accepted.

**5. PAYMENT.**

**Bridge Cleaning (24981EC):** Payment at the contract unit price for “Lump Sum” is full compensation for furnishing all materials, Debris Removal, Pressure Washing and all incidental items required to complete this work as specified in this note and attached detailed drawings.

**Concrete Coating (24982EC):** Payment at the contract unit price for “Lump Sum” is full compensation for furnishing all materials, applying the concrete coatings and all incidental items required to complete this work as specified in this note and attached detailed drawings.

**Clean and Paint Structural Steel (08434):** Payment at the contract unit price for “Lump Sum” is full compensation for furnishing all materials, cleaning and painting all steel specified and all incidental items required to complete this work as specified in this note and attached detailed drawings.

**Paint Mural (25018EC):** Payment at the contract unit price for “Lump Sum” is full compensation for furnishing all materials, applying the coating for the mural and all incidental items required to complete this work as specified in this note and attached detailed drawings.

## SPECIAL NOTE FOR MAINTAIN AND CONTROL TRAFFIC

All lane closures on this project shall be in accordance with Kentucky Department of Highways Standard Drawings No. **TTC-100, TTC-110 and the FHWA Manual for Uniform Traffic Control Devices (Current Editions) unless otherwise specified.** Lane closures should be used only when absolutely necessary and kept to the shortest duration possible in order to minimize disruption to the traveling public. No work will be conducted over unprotected traffic at any location. At the discretion of the Engineer, lane closures may be restricted on holiday weekends.

The contractor shall be required to submit in writing, to the department, his complete work schedule 14 days prior to the Pre-Construction Conference. The contractor shall be required to coordinate his efforts with those of any other contractor in the construction area so as to eliminate any lane closures which conflict with this traffic note.

In the event it becomes necessary to make emergency repairs at this project by state forces or by other outside contractors, the (painting) contractor shall agree to alter his work pattern as directed by the engineer so as not to interfere with the emergency work.

The contractor shall be required to furnish all traffic control devices whenever his operations endanger or interfere with vehicular traffic as determined by the engineer. The contractor shall furnish any additional traffic control devices necessary to protect traffic and his workmen. Any costs associated with the added traffic control devices (including arrow boards) shall be incidental to the contract lump sum amount for "maintain and control traffic."

Placement of all devices for lane closures shall start and proceed in the direction of flow of traffic. Removal of devices shall start at the end of the construction area and proceed toward oncoming traffic. The contractor shall provide for the installation of all necessary traffic control devices before beginning work and their immediate removal as soon as work is suspended or completed. During the fully operational periods, when no lane closures are permitted, all equipment shall be totally removed from the job site. Traffic control signs shall be removed or covered (if left in a curb lane).

The contractor's vehicles shall always move with and not across or against the flow of traffic. Vehicles shall enter or leave work areas in a manner that will not be hazardous to or interfere with normal roadway traffic. Vehicles shall not park or stop except within designated work areas.

Personal vehicles shall not be permitted to park within the state right-of-way. The contractor's vehicles shall be prohibited from crossing the roadway and all pedestrian movement of the contractor's personnel on the roadway shall be limited to within the closed work area.

**037B00016N**

**Lafayette Ave. (Route Below)**

Maintain one usable 12 foot minimum lane. Flagging or traffic signals shall be used. If traffic signals are used the Contractor shall use flagging to minimize impact on school bus traffic when school is in session. The Contractor shall be responsible for establishing the dates and times when school bus traffic will impact the job site. All lane closures shall be removed when not working.

**US 60 (Route Above)**

Maintain one usable 12 foot minimum lane. Flagging or traffic signals shall be used. If traffic signals are used the Contractor shall use flagging to minimize impact on school bus traffic when school is in session. The Contractor shall be responsible for establishing the dates and times when school bus traffic will impact the job site. No lane closures will be permitted between 6:00AM-9:00AM and 3:00PM-6:00PM. All lane closures shall be removed when not working.

**MEASUREMENT.**

**A. Maintain and Control Traffic:** The Department will measure the quantity by Lump Sum, completed and accepted.

**PAYMENT.**

**A. Maintain and Control Traffic (02650).** Payment of the contract lump sum amount for "maintain and control traffic" shall be full compensation for all items necessary to maintain and control traffic as specified for this project. All traffic control items shall remain the property of the contractor when the work is complete.



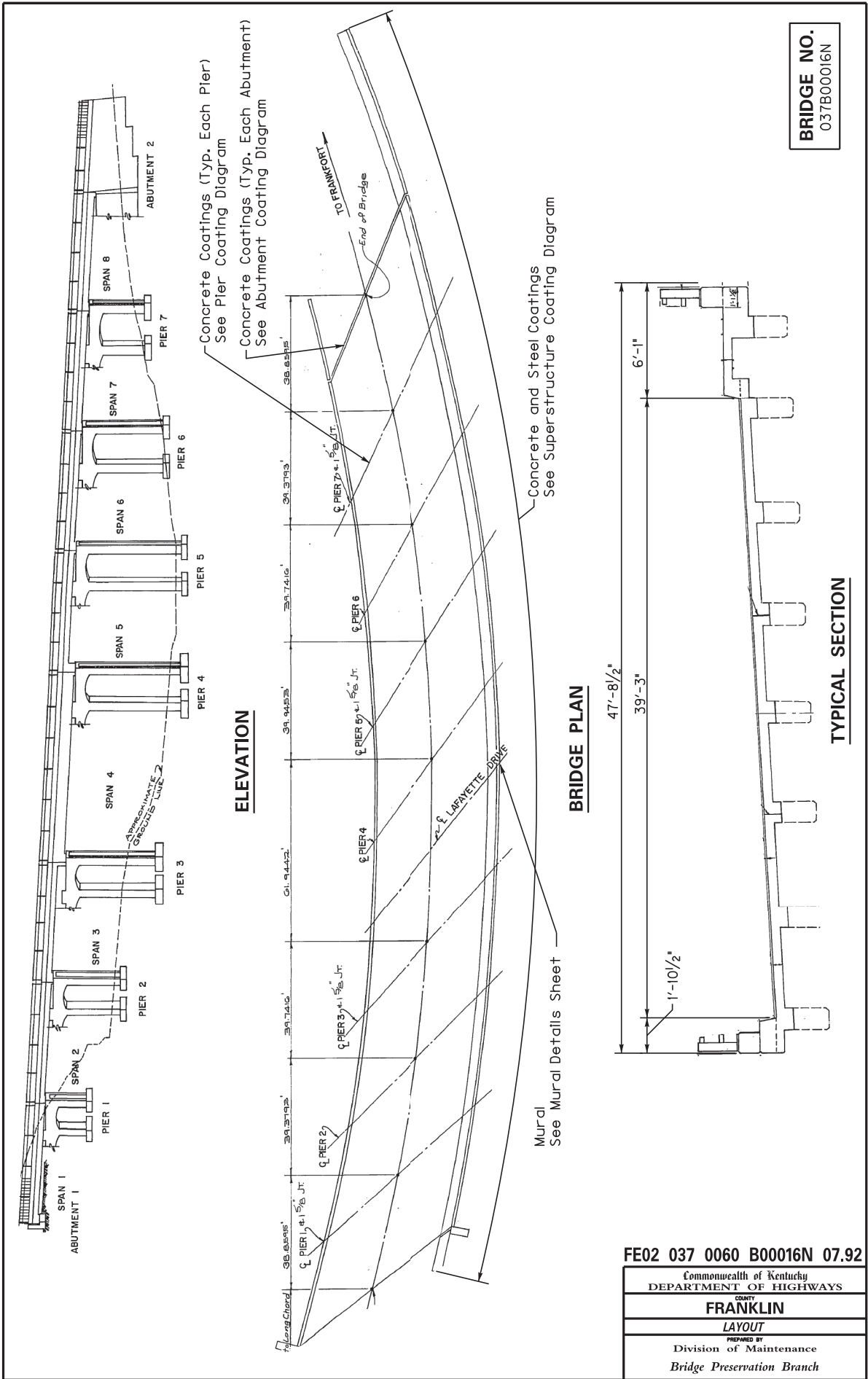

FE02 037 0060 B00016N 07.92

Commonwealth of Kentucky DEPARTMENT OF HIGHWAYS
FRANKLIN
LAYOUT
PREPARED BY Division of Maintenance Bridge Preservation Branch

**BRIDGE NO.**  
 037B00016N

- ① Faces of parapet walls and overhang the entire length of bridge including the abutment wing walls, faces of all beams, diaphragms and bottom of slab the entire of bridge shall have debris removed, pressure washed and have concrete coatings applied.  
 Color: Blue ~ L\* = 66.56, a\* = -7.26, b\* = -20.10
- ② All faces of steel parapet railing the entire length of bridge shall be cleaned, pressure washed and have steel coatings applied.  
 Color: White ~ L\* = 74.94, a\* = -1.54, b\* = 3.92

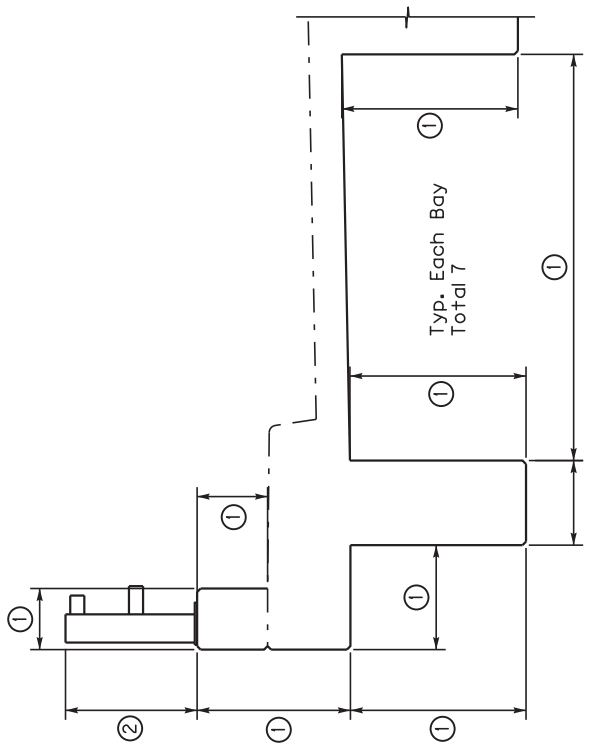

**SUPERSTRUCTURE COATING DIAGRAM**

FE02 037 0060 B00016N 07.92

Commonwealth of Kentucky DEPARTMENT OF HIGHWAYS
FRANKLIN
SUPERSTRUCTURE COATING DIAGRAM
PREPARED BY Division of Maintenance Bridge Preservation Branch

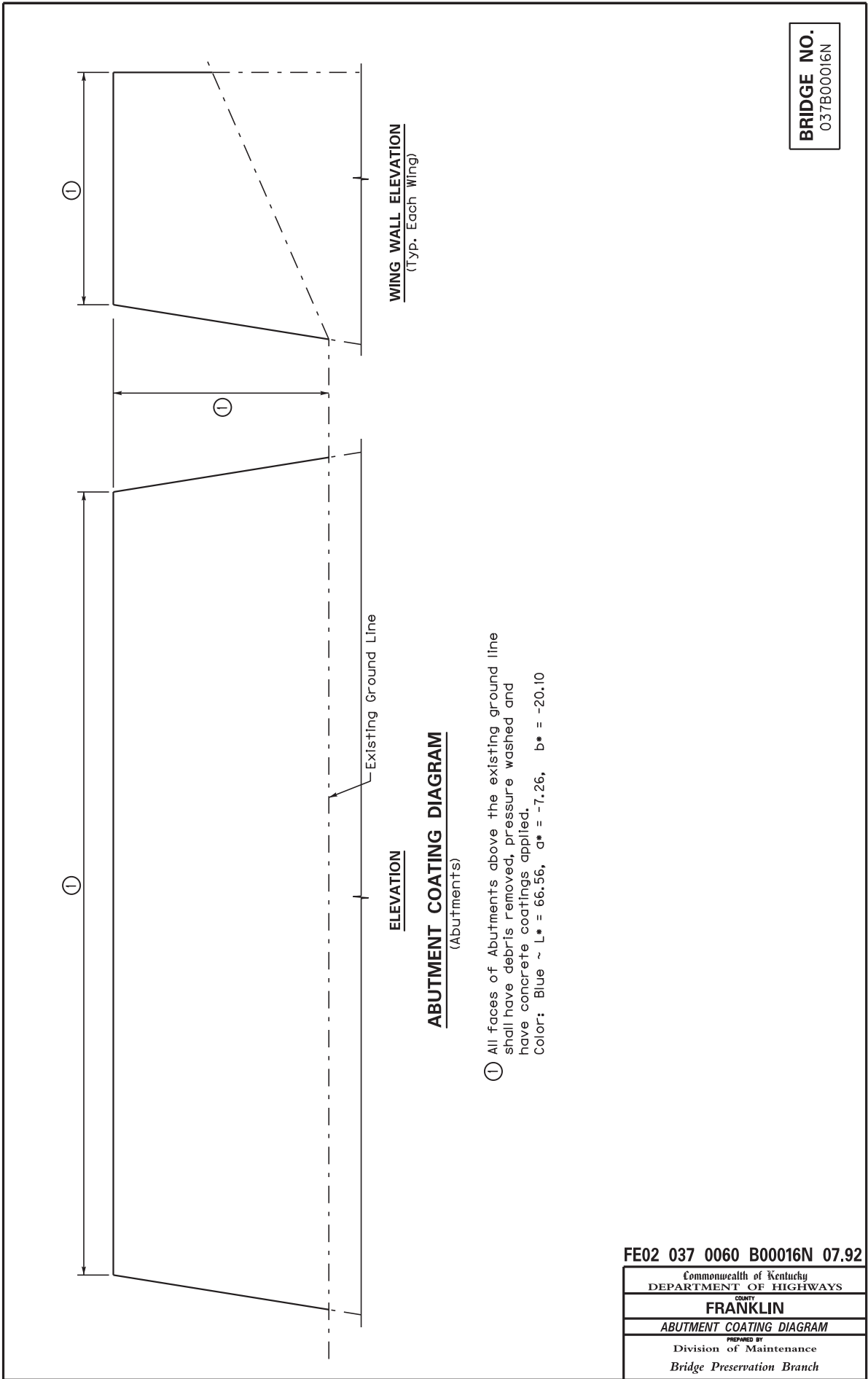

**BRIDGE NO.**  
 037B00016N

① All faces of Abutments above the existing ground line shall have debris removed, pressure washed and have concrete coatings applied.  
 Color: Blue ~ L\* = 66.56, a\* = -7.26, b\* = -20.10

FE02 037 0060 B00016N 07.92	
Commonwealth of Kentucky DEPARTMENT OF HIGHWAYS	
COUNTY <b>FRANKLIN</b>	
ABUTMENT COATING DIAGRAM	
PREPARED BY Division of Maintenance Bridge Preservation Branch	

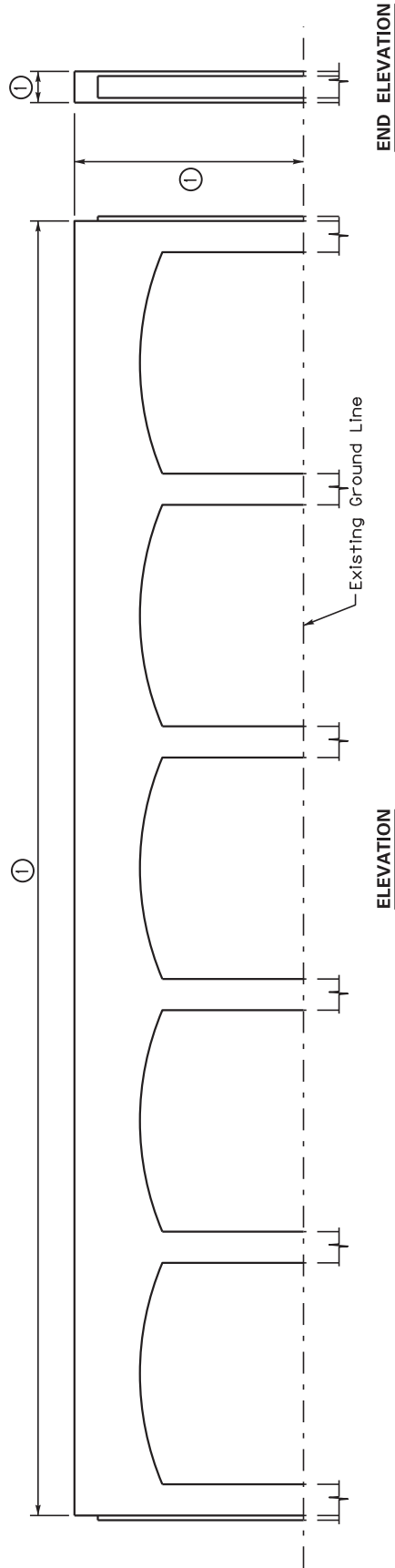

ELEVATION

END ELEVATION

**PIER COATING DIAGRAM**

(Typical Each Pier)

- ① All faces of Piers above the existing ground line shall have debris removed, pressure washed and have concrete coatings applied.  
 Color: Blue ~ L\* = 66.56, a\* = -7.26, b\* = -20.10

**BRIDGE NO.**  
 037B00016N

FE02 037 0060 B00016N 07.92

Commonwealth of Kentucky DEPARTMENT OF HIGHWAYS
COUNTY <b>FRANKLIN</b>
PREPARED BY <b>PIER COATING DIAGRAM</b>
Division of Maintenance Bridge Preservation Branch

**BRIDGE NO.**  
037B00016N

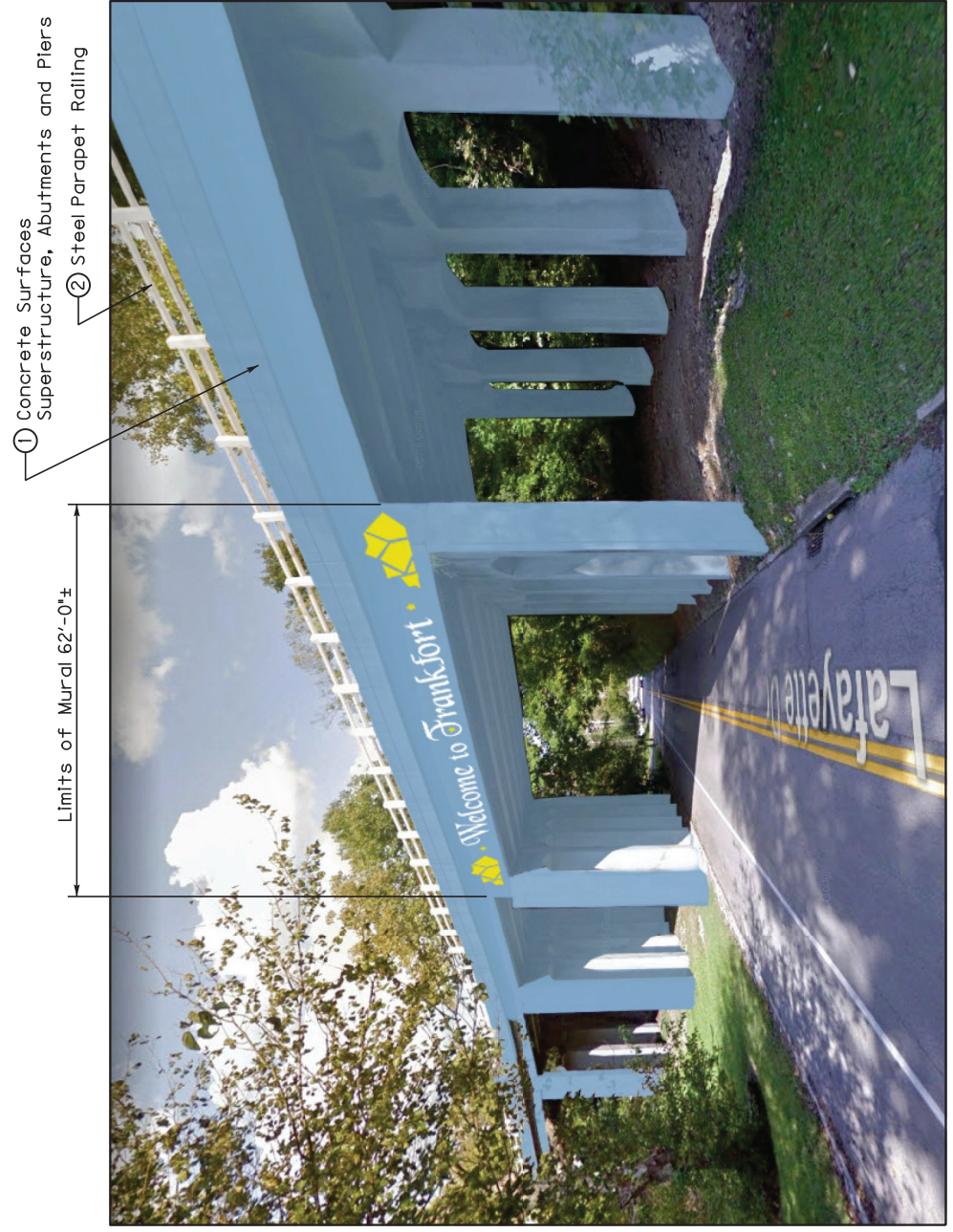

FE02 037 0060 B00016N 07.92

Commonwealth of Kentucky DEPARTMENT OF HIGHWAYS
COUNTY <b>FRANKLIN</b>
<i>MURAL DETAILS</i>
PREPARED BY Division of Maintenance Bridge Preservation Branch

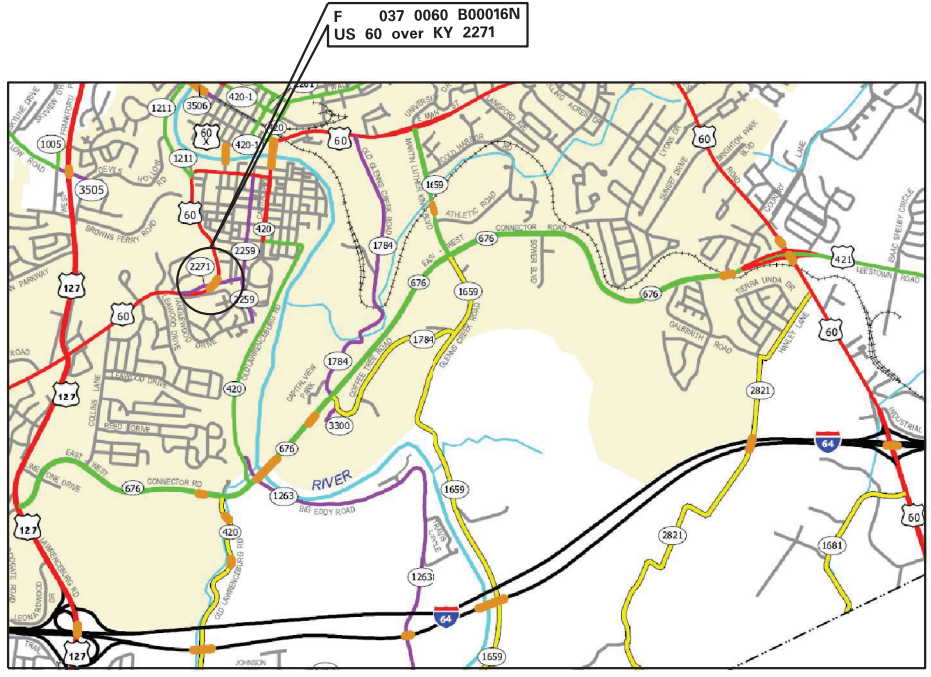

**LOCATION MAP – FRANKLIN COUNTY**

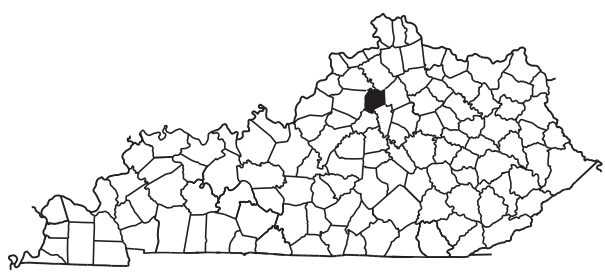

**FE02 037 0060 B00016N 07.92**

Commonwealth of Kentucky DEPARTMENT OF HIGHWAYS
COUNTY <b>FRANKLIN</b>
<i>LOCATION MAP</i>
PREPARED BY Division of Maintenance Bridge Preservation Branch

**PART II**  
**SPECIFICATIONS AND STANDARD DRAWINGS**

### **SPECIFICATIONS REFERENCE**

Any reference in the plans or proposal to previous editions of the *Standard Specifications for Road and Bridge Construction* and *Standard Drawings* are superseded by *Standard Specifications for Road and Bridge Construction, Edition of 2012* and *Standard Drawings, Edition of 2016*.



## **SUPPLEMENTAL SPECIFICATIONS**

The contractor shall use the Supplemental Specifications that are effective at the time of letting.  
The Supplemental Specifications can be found at the following link:

<http://transportation.ky.gov/Construction/Pages/Kentucky-Standard-Specifications.aspx>

**PART III**

**EMPLOYMENT, WAGE AND RECORD REQUIREMENTS**

**TRANSPORTATION CABINET  
DEPARTMENT OF HIGHWAYS**

**LABOR AND WAGE REQUIREMENTS  
APPLICABLE TO OTHER THAN FEDERAL-AID SYSTEM PROJECTS**

- I. Application
- II. Nondiscrimination of Employees (KRS 344)

**I. APPLICATION**

1. These contract provisions shall apply to all work performed on the contract by the contractor with his own organization and with the assistance of workmen under his immediate superintendence and to all work performed on the contract by piecework, station work or by subcontract. The contractor's organization shall be construed to include only workmen employed and paid directly by the contractor and equipment owned or rented by him, with or without operators.

2. The contractor shall insert in each of his subcontracts all of the stipulations contained in these Required Provisions and such other stipulations as may be required.

3. A breach of any of the stipulations contained in these Required Provisions may be grounds for termination of the contract.

3. If the contractor is in control of apprenticeship or other training or retraining, including on-the-job training programs, he shall not discriminate against an individual because of his race, color, religion, national origin, sex, disability or age forty (40) and over, in admission to, or employment in any program established to provide apprenticeship or other training.

4. The contractor will send to each labor union or representative of workers with which he has a collective bargaining agreement or other contract or understanding, a notice to be provided advising the said labor union or workers' representative of the contractor's commitments under this section, and shall post copies of the notice in conspicuous places available to employees and applicants for employment. The contractor will take such action with respect to any subcontract or purchase order as the administrating agency may direct as a means of enforcing such provisions, including sanctions for non-compliance.

Revised: January 25, 2017

**II. NONDISCRIMINATION OF EMPLOYEES**

**AN ACT OF THE KENTUCKY  
GENERAL ASSEMBLY TO PREVENT  
DISCRIMINATION IN EMPLOYMENT  
KRS CHAPTER 344  
EFFECTIVE JUNE 16, 1972**

The contract on this project, in accordance with KRS Chapter 344, provides that during the performance of this contract, the contractor agrees as follows:

1. The contractor shall not fail or refuse to hire, or shall not discharge any individual, or otherwise discriminate against an individual with respect to his compensation, terms, conditions, or privileges of employment, because of such individual's race, color, religion, national origin, sex, disability or age (forty and above); or limit, segregate, or classify his employees in any way which would deprive or tend to deprive an individual of employment opportunities or otherwise adversely affect his status as an employee, because of such individual's race, color, religion, national origin, sex, disability or age forty (40) and over. The contractor agrees to post in conspicuous places, available to employees and applicants for employment, notices to be provided setting forth the provisions of this nondiscrimination clause.

2. The contractor shall not print or publish or cause to be printed or published a notice or advertisement relating to employment by such an employer or membership in or any classification or referral for employment by the employment agency, indicating any preference, limitation, specification, or discrimination, based on race, color, religion, national origin, sex, or age forty (40) and over, or because the person is a qualified individual with a disability, except that such a notice or advertisement may indicate a preference, limitation, or specification based on religion, national origin, sex, or age forty (40) and over, or because the person is a qualified individual with a disability, when religion, national origin, sex, or age forty (40) and over, or because the person is a qualified individual with a disability, is a bona fide occupational qualification for employment.

## EXECUTIVE BRANCH CODE OF ETHICS

In the 1992 regular legislative session, the General Assembly passed and Governor Brereton Jones signed Senate Bill 63 (codified as KRS 11A), the Executive Branch Code of Ethics, which states, in part:

KRS 11A.040 (7) provides:

No present or former public servant shall, within six (6) months following termination of his office or employment, accept employment, compensation, or other economic benefit from any person or business that contracts or does business with, or is regulated by, the state in matters in which he was directly involved during the last thirty-six (36) months of his tenure. This provision shall not prohibit an individual from returning to the same business, firm, occupation, or profession in which he was involved prior to taking office or beginning his term of employment, or for which he received, prior to his state employment, a professional degree or license, provided that, for a period of six (6) months, he personally refrains from working on any matter in which he was directly involved during the last thirty-six (36) months of his tenure in state government. This subsection shall not prohibit the performance of ministerial functions, including but not limited to filing tax returns, filing applications for permits or licenses, or filing incorporation papers, nor shall it prohibit the former officer or public servant from receiving public funds disbursed through entitlement programs.

KRS 11A.040 (9) states:

A former public servant shall not represent a person or business before a state agency in a matter in which the former public servant was directly involved during the last thirty-six (36) months of his tenure, for a period of one (1) year after the latter of:

- a) The date of leaving office or termination of employment; or
- b) The date the term of office expires to which the public servant was elected.

This law is intended to promote public confidence in the integrity of state government and to declare as public policy the idea that state employees should view their work as a public trust and not as a way to obtain private benefits.

If you have worked for the executive branch of state government within the past six months, you may be subject to the law's prohibitions. The law's applicability may be different if you hold elected office or are contemplating representation of another before a state agency.

Also, if you are affiliated with a firm which does business with the state and which employs former state executive-branch employees, you should be aware that the law may apply to them.

In case of doubt, the law permits you to request an advisory opinion from the Executive Branch Ethics Commission, 3 Fountain Place, Frankfort, Kentucky 40601; telephone (502) 564-7954.

Revised: January 27, 2017

### **Kentucky Equal Employment Opportunity Act of 1978**

The requirements of the Kentucky Equal Employment Opportunity Act of 1978 (KRS 45.560-45.640) shall apply to this Contract. The apparent low Bidder will be required to submit EEO forms to the Division of Construction Procurement, which will then forward to the Finance and Administration Cabinet for review and approval. No award will become effective until all forms are submitted and EEO/CC has certified compliance. The required EEO forms are as follows:

- EEO-1: Employer Information Report
- Affidavit of Intent to Comply
- Employee Data Sheet
- Subcontractor Report

These forms are available on the Finance and Administration's web page under ***Vendor Information, Standard Attachments and General Terms*** at the following address:  
**<https://www.eProcurement.ky.gov>**.

Bidders currently certified as being in compliance by the Finance and Administration Cabinet may submit a copy of their approval letter in lieu of the referenced EEO forms.

For questions or assistance please contact the Finance and Administration Cabinet by email at **[finance.contractcompliance@ky.gov](mailto:finance.contractcompliance@ky.gov)** or by phone at 502-564-2874.

# EMPLOYEE RIGHTS UNDER THE FAIR LABOR STANDARDS ACT

THE UNITED STATES DEPARTMENT OF LABOR WAGE AND HOUR DIVISION

## FEDERAL MINIMUM WAGE

# \$7.25

 PER HOUR

BEGINNING JULY 24, 2009

**OVERTIME PAY** At least 1½ times your regular rate of pay for all hours worked over 40 in a workweek.

**CHILD LABOR** An employee must be at least **16** years old to work in most non-farm jobs and at least **18** to work in non-farm jobs declared hazardous by the Secretary of Labor.

Youths **14** and **15** years old may work outside school hours in various non-manufacturing, non-mining, non-hazardous jobs under the following conditions:

**No more than**

- **3** hours on a school day or **18** hours in a school week;
- **8** hours on a non-school day or **40** hours in a non-school week.

Also, work may not begin before **7 a.m.** or end after **7 p.m.**, except from June 1 through Labor Day, when evening hours are extended to **9 p.m.** Different rules apply in agricultural employment.

**TIP CREDIT** Employers of “tipped employees” must pay a cash wage of at least \$2.13 per hour if they claim a tip credit against their minimum wage obligation. If an employee’s tips combined with the employer’s cash wage of at least \$2.13 per hour do not equal the minimum hourly wage, the employer must make up the difference. Certain other conditions must also be met.

**ENFORCEMENT** The Department of Labor may recover back wages either administratively or through court action, for the employees that have been underpaid in violation of the law. Violations may result in civil or criminal action.

Employers may be assessed civil money penalties of up to \$1,100 for each willful or repeated violation of the minimum wage or overtime pay provisions of the law and up to \$11,000 for each employee who is the subject of a violation of the Act’s child labor provisions. In addition, a civil money penalty of up to \$50,000 may be assessed for each child labor violation that causes the death or serious injury of any minor employee, and such assessments may be doubled, up to \$100,000, when the violations are determined to be willful or repeated. The law also prohibits discriminating against or discharging workers who file a complaint or participate in any proceeding under the Act.

### ADDITIONAL INFORMATION

- Certain occupations and establishments are exempt from the minimum wage and/or overtime pay provisions.
- Special provisions apply to workers in American Samoa and the Commonwealth of the Northern Mariana Islands.
- Some state laws provide greater employee protections; employers must comply with both.
- The law requires employers to display this poster where employees can readily see it.
- Employees under 20 years of age may be paid \$4.25 per hour during their first 90 consecutive calendar days of employment with an employer.
- Certain full-time students, student learners, apprentices, and workers with disabilities may be paid less than the minimum wage under special certificates issued by the Department of Labor.

For additional information:



# 1-866-4-USWAGE

(1-866-487-9243) TTY: 1-877-889-5627



# WWW.WAGEHOUR.DOL.GOV

**PART IV**  
**INSURANCE**

## INSURANCE

The Contractor shall procure and maintain the following insurance in addition to the insurance required by law:

- 1) Commercial General Liability-Occurrence form – not less than \$2,000,000 General aggregate, \$2,000,000 Products & Completed Aggregate, \$1,000,000 Personal & Advertising, \$1,000,000 each occurrence.
- 2) Automobile Liability- \$1,000,000 per accident
- 3) Employers Liability:
  - a) \$100,000 Each Accident Bodily Injury
  - b) \$500,000 Policy limit Bodily Injury by Disease
  - c) \$100,000 Each Employee Bodily Injury by Disease
- 4) The insurance required above must be evidenced by a Certificate of Insurance and this Certificate of Insurance must contain one of the following statements:
  - a) "policy contains no deductible clauses."
  - b) "policy contains \_\_\_\_\_ (amount) deductible property damage clause but company will pay claim and collect the deductible from the insured."
- 5) KENTUCKY WORKMEN'S COMPENSATION INSURANCE. The contractor shall furnish evidence of coverage of all his employees or give evidence of self-insurance by submitting a copy of a certificate issued by the Workmen's Compensation Board.

The cost of insurance is incidental to all contract items. All subcontractors must meet the same minimum insurance requirements.



**PART V**  
**BID ITEMS**

### PROPOSAL BID ITEMS

192970

Page 1 of 1

Report Date 4/26/19

#### Section: 0001 - BRIDGES

LINE	BID CODE	ALT	DESCRIPTION	QUANTITY	UNIT	UNIT PRIC	FP	AMOUNT
0010	02650		MAINTAIN & CONTROL TRAFFIC - -037B00016N	1.00	LS		\$	
0020	08434		CLEAN & PAINT STRUCTURAL STEEL - 037B00016N	1.00	LS		\$	
0030	24981EC		BRIDGE CLEANING - 037B00016N	1.00	LS		\$	
0040	24982EC		CONCRETE COATING - 037B00016N	1.00	LS		\$	
0050	25018EC		PAINT MURAL - 037B00016N	1.00	L S		\$	

#### Section: 0002 - DEMOB

LINE	BID CODE	ALT	DESCRIPTION	QUANTITY	UNIT	UNIT PRIC	FP	AMOUNT
0060	02568		MOBILIZATION	1.00	LS		\$	
0070	02569		DEMOBILIZATION	1.00	LS		\$	