



**CALL NO. 320**

**CONTRACT ID. 202902**

**WHITLEY COUNTY**

**FED/STATE PROJECT NUMBER FE02 118 0075 B00063L,R**

**DESCRIPTION I-75 OVER LYNN CAMP CREEK MP 27.92**

**WORK TYPE BRIDGE STEEL REPAIRS**

**PRIMARY COMPLETION DATE 11/15/2020**

**LETTING DATE: February 21,2020**

Sealed Bids will be received electronically through the Bid Express bidding service until 10:00 am EASTERN STANDARD TIME February 21,2020. Bids will be publicly announced at 10:00 am EASTERN STANDARD TIME.

**NO PLANS ASSOCIATED WITH THIS PROJECT.**

**REQUIRED BID PROPOSAL GUARANTY:** Not less than 5% of the total bid.

## TABLE OF CONTENTS

|          |  |
|----------|--|
| PART I   | SCOPE OF WORK  |
|          | <ul style="list-style-type: none"><li>• PROJECT(S), COMPLETION DATE(S), &amp; LIQUIDATED DAMAGES</li><li>• CONTRACT NOTES</li><li>• STATE CONTRACT NOTES</li><li>• SPECIAL NOTE(S) APPLICABLE TO PROJECT</li></ul>                                   |
| PART II  | SPECIFICATIONS AND STANDARD DRAWINGS   |
|          | <ul style="list-style-type: none"><li>• SPECIFICATIONS REFERENCE</li><li>• SUPPLEMENTAL SPECIFICATION</li></ul>  |
| PART III | EMPLOYMENT, WAGE AND RECORD REQUIREMENTS   |
|          | <ul style="list-style-type: none"><li>• LABOR AND WAGE REQUIREMENTS</li><li>• EXECUTIVE BRANCH CODE OF ETHICS</li><li>• KENTUCKY EQUAL EMPLOYMENT OPPORTUNITY ACT OF 1978<br/>LOCALITY / STATE</li><li>• PROJECT WAGE RATES / STATE FUNDED</li></ul> |
| PART IV  | INSURANCE  |
| PART V   | BID ITEMS  |

**PART I**  
**SCOPE OF WORK**

## ADMINISTRATIVE DISTRICT - 11

**CONTRACT ID - 202902**

**FE02 118 0075 B00063L,R**

**COUNTY - WHITLEY**

**PCN - MB11800752001**

**FE02 118 0075 B00063L,R**

INTERSTATE 75 (MP 27.916). LONDON - WILLIAMSBURG ROAD

I-75 OVER LYNN CAMP CREEK.BRIDGE STEEL REPAIRS

GEOGRAPHIC COORDINATES LATITUDE 36:57:51.00 LONGITUDE 84:06:54.00

**COMPLETION DATE(S):**

COMPLETED BY 11/15/2020

APPLIES TO ENTIRE CONTRACT  
SEE MAINTAIN & TRAFFIC NOTE

## **CONTRACT NOTES**

### **PROPOSAL ADDENDA**

All addenda to this proposal must be applied when calculating bid and certified in the bid packet submitted to the Kentucky Department of Highways. Failure to use the correct and most recent addenda may result in the bid being rejected.

### **BID SUBMITTAL**

Bidder must use the Department's electronic bidding software. The Bidder must download the bid file located on the Bid Express website ([www.bidx.com](http://www.bidx.com)) to prepare a bid packet for submission to the Department. The bidder must submit electronically using Bid Express.

### **JOINT VENTURE BIDDING**

Joint venture bidding is permissible. All companies in the joint venture must be prequalified in one of the work types in the Qualifications for Bidders for the project. The bidders must get a vendor ID for the joint venture from the Division of Construction Procurement and register the joint venture as a bidder on the project. Also, the joint venture must obtain a digital ID from Bid Express to submit a bid. A joint bid bond of 5% may be submitted for both companies or each company may submit a separate bond of 5%.

### **UNDERGROUND FACILITY DAMAGE PROTECTION**

The contractor shall make every effort to protect underground facilities from damage as prescribed in the Underground Facility Damage Protection Act of 1994, Kentucky Revised Statute KRS 367.4901 to 367.4917. It is the contractor's responsibility to determine and take steps necessary to be in compliance with federal and state damage prevention directives. When prescribed in said directives, the contractor shall submit Excavation Locate Requests to the Kentucky Contact Center (KY811) via web ticket entry. The submission of this request does not relieve the contractor from the responsibility of contacting non-member facility owners, whom shall be contacted through their individual Protection Notification Center. Non-compliance with these directives can result in the enforcement of penalties.

### **REGISTRATION WITH THE SECRETARY OF STATE BY A FOREIGN ENTITY**

Pursuant to KRS 176.085(1)(b), an agency, department, office, or political subdivision of the Commonwealth of Kentucky shall not award a state contract to a person that is a foreign entity required by [KRS 14A.9-010](#) to obtain a certificate of authority to transact business in the Commonwealth ("certificate") from the Secretary of State under [KRS 14A.9-030](#) unless the person produces the certificate within fourteen (14) days of the bid or proposal opening. If the foreign entity is not required to obtain a certificate as provided in [KRS 14A.9-010](#), the foreign entity should identify the applicable exception. Foreign entity is defined within [KRS 14A.1-070](#).

**For all foreign entities required to obtain a certificate of authority to transact business in the Commonwealth, if a copy of the certificate is not received by the contracting agency within the time frame identified above, the foreign entity's solicitation response shall be deemed non-responsive or the awarded contract shall be cancelled.**

Businesses can register with the Secretary of State at <https://secure.kentucky.gov/sos/ftbr/welcome.aspx>.

### **SPECIAL NOTE FOR PROJECT QUESTIONS DURING ADVERTISEMENT**

Questions about projects during the advertisement should be submitted in writing to the Division of Construction Procurement. This may be done by fax (502) 564-7299 or email to [kytc.projectquestions@ky.gov](mailto:kytc.projectquestions@ky.gov). The Department will attempt to answer all submitted questions. The Department reserves the right not to answer if the question is not pertinent or does not aid in clarifying the project intent.

The deadline for posting answers will be 3:00 pm Eastern Daylight Time, the day preceding the Letting. Questions may be submitted until this deadline with the understanding that the later a question is submitted, the less likely an answer will be able to be provided.

The questions and answers will be posted for each Letting under the heading "Questions & Answers" on the Construction Procurement website ([www.transportation.ky.gov/contract](http://www.transportation.ky.gov/contract)). The answers provided shall be considered part of this Special Note and, in case of a discrepancy, will govern over all other bidding documents.

### **HARDWOOD REMOVAL RESTRICTIONS**

The US Department of Agriculture has imposed a quarantine in Kentucky and several surrounding states, to prevent the spread of an invasive insect, the emerald ash borer. Hardwood cut in conjunction with the project may not be removed from the state. Chipping or burning on site is the preferred method of disposal.

### **INSTRUCTIONS FOR EXCESS MATERIAL SITES AND BORROW SITES**

Identification of excess material sites and borrow sites shall be the responsibility of the Contractor. The Contractor shall be responsible for compliance with all applicable state and federal laws and may wish to consult with the US Fish and Wildlife Service to seek protection under Section 10 of the Endangered Species Act for these activities.

### **ACCESS TO RECORDS**

The contractor, as defined in KRS 45A.030 (9) agrees that the contracting agency, the Finance and Administration Cabinet, the Auditor of Public Accounts, and the Legislative Research Commission, or their duly authorized representatives, shall have access to any books, documents, papers, records, or other evidence, which are directly pertinent to this contract for the purpose of financial audit or program review. Records and other prequalification information confidentially

disclosed as part of the bid process shall not be deemed as directly pertinent to the contract and shall be exempt from disclosure as provided in KRS 61.878(1)(c). The contractor also recognizes that any books, documents, papers, records, or other evidence, received during a financial audit or program review shall be subject to the Kentucky Open Records Act, KRS 61.870 to 61.884.

In the event of a dispute between the contractor and the contracting agency, Attorney General, or the Auditor of Public Accounts over documents that are eligible for production and review, the Finance and Administration Cabinet shall review the dispute and issue a determination, in accordance with Secretary's Order 11-004.

April 30, 2018

## **SPECIAL NOTE FOR RECIPROCAL PREFERENCE**

### **RECIPROCAL PREFERENCE TO BE GIVEN BY PUBLIC AGENCIES TO RESIDENT BIDDERS**

By reference, KRS 45A.490 to 45A.494 are incorporated herein and in compliance regarding the bidders residency. Bidders who want to claim resident bidder status should complete the Affidavit for Claiming Resident Bidder Status along with their bid in the electronic bidding software. Submittal of the Affidavit should be done along the bid in Bid Express.

April 30, 2018



**SPECIAL NOTES  
DISTRICT NO. 11  
BRIDGE STEEL REPAIR  
WHITLEY COUNTY  
CID NO. 202902**

**FE02 118 0075 B00063L 27.92**

I-75 over Lynn Camp Creek

Latitude – 36° 57' 51.00''

Longitude – 084° 06' 54.00''

**Description**

160'-200'-160' WSPG Spans, Existing Drawing Nos. 16849 and 24121

**FE02 118 0075 B00063R 27.92**

I-75 over Lynn Camp Creek

Latitude – 36° 57' 50.00''

Longitude – 084° 06' 52.00''

**Description**

140'-200'-140' WSPG Spans, Existing Drawing Nos. 16848 and 24121

**INDEX**

SPECIAL NOTE FOR STEEL REPAIR

SPECIAL NOTE FOR MAINTAIN AND CONTROL TRAFFIC

## **SPECIAL NOTE FOR STEEL REPAIR**

**1. DESCRIPTION.** Perform all work in accordance with the Kentucky Transportation Cabinet, Department of Highway's Standard Specifications for Road and Bridge Construction and applicable Supplemental Specifications, the Standard Drawings (Current Editions), this Note, and the attached detailed drawings for Stringer Web Repair and Floor Beam Retrofit. Section references are to the Standard Specifications. This work consists of the following: (1) Furnish all labor, materials, tools, and equipment; (2) Maintain and control traffic; (3) Steel Repair; (4) Any other work specified as part of this contract.

**2. MATERIALS**

**A. Paint**

See Section 607.03.23.

**3. CONSTRUCTION.**

**A. Steel Repair**

Complete all repairs as specified in this special note and shown in the attached detailed drawings.

**B. Removal.**

Remove existing steel as shown on the attached detailed drawings. Dispose of all removed material entirely away from the job site. This work shall be incidental to the unit price bid "Each" for "Steel Repair".

**C. Steel Core Repair**

This work shall consist of performing steel coring as a retrofit in the structural steel locations and diameter shown on the plans, or as directed by the Engineer. The Contractor shall provide personnel experience in this type of work in accordance with section 607. Prior to performing coring operations, the Contractor shall layout the location of each core hole in the presence of the Engineer. The area to be cored shall have surface contaminants removed in accordance with section 607. Prior to performing coring operations, the Contractor shall verify that the proposed core will cut and fasteners, welds or other plates. The Contractor shall notify the Engineer if there is a conflict between the proposed core and any of these elements. Cores shall be taken with commercially available magnetic drills. Core diameters shall be as shown on the plans. After each core is complete, the Contractor shall grind the core edges of the core smooth to eliminate imperfections including nicks and gouges from the coring operations. The Contractor shall perform final surface finishing of all cored, ground edges and surfaces with a stone wheel and remove all remaining imperfections with a sand paper "Flapper" wheel with grit roughness not rougher than grade 120 to achieve a smooth surface. All grinding shall be complete parallel to the longitudinal direction of each member. The Contractor shall remove the minimum amount of steel necessary to accomplish this work and shall paint the bare steel exposed by this work. Contrary to section 607 the areas to be painted shall receive the primer coating only.

**D. Weld Repair, Grinding**

The Contractor shall provide personnel experience in this type of work in accordance with section 607. Approximately 178 repairs that include intersection welds are anticipated for repair details as shown on the plans. The Contractor shall measure and confirm the actual locations using a method approved by the Engineer. Location proposed for repair shall be verified by the Engineer. The repair area shall have surface contaminants removed in accordance with section 607. The Contractor shall grind intersection welds to provide a minimum 1/4" in. minimum gap between remaining weld toes exposing the web for 1/4" in. minimum width. The Contractor shall grind all edges and surfaces with a sand paper "Flapper" wheel with grit roughness not rougher than grade 120 to achieve a smooth surface. All grinding shall be complete parallel to the longitudinal direction of each member. The Contractor shall remove the minimum amount of steel necessary to accomplish this work and shall paint the bare steel exposed by this work. Contrary to section 607 the areas to be painted shall receive the primer coating only.

**E. Damage to the structure**

The Contractor shall bear all responsibility and expense for any and all damage to the structure during the repair work, even to the removal and replacement of a fallen span, should the fallen span result from the Contractors actions.

**F. Residual Lead.** Residual lead paint may still be on bridge. The Contractor shall take all necessary protective measures including worker safety and environmental regulations when performing this work. The Department will not consider any claims based on residual lead paint.

**4. MEASUREMENT.**

**Steel Repair ~ Type A or B:** The Department will measure the quantity as "Each for Steel Repair.

**5. PAYMENT.**

**Steel Repair ~ Type A or B (24879EC).** Payment at the contract unit price for "Each" is full compensation for furnishing and installing all material as specified.

## **SPECIAL NOTE FOR MAINTAIN AND CONTROL TRAFFIC**

All lane closures on this project shall be in accordance with **Kentucky Department of Highways Standard Specifications and Standard Drawings Nos. TTC-115, TTC-135 and the FHWA Manual for Uniform Traffic Control Devices (Current Editions)**. At the discretion of the Engineer, lane closures may be restricted on holiday weekends.

### **EMERGENCY REPAIRS**

In the event it becomes necessary to make emergency repairs at this project by state forces or by other outside contractors, the contractor agrees to alter his work pattern as directed by the engineer so as not to interfere with the emergency work.

### **TRAFFIC CONTROL DEVICES**

The contractor will be required to furnish all traffic control devices whenever his operations endanger or interfere with vehicular traffic as determined by the engineer. The contractor shall furnish any additional traffic control devices necessary to protect traffic and his workmen. Any costs associated with the added traffic control devices (including arrow boards) shall be incidental to the contract lump sum amount for "maintain and control traffic." Placement of all devices for lane closures shall start and proceed in the direction of flow of traffic. Removal of devices shall start at the end of the construction area and proceed toward oncoming traffic. The contractor shall provide for the installation of all necessary traffic control devices before beginning work and their immediate removal as soon as work is suspended or completed. During the fully operational periods, when no lane closures are permitted, all equipment shall be totally removed from the job site. Traffic control signs shall be removed or covered (if left in a curb lane).

### **VEHICLES**

The contractor's vehicles shall always move with and not across or against the flow of traffic. Vehicles shall enter or leave work areas in a manner that will not be hazardous to or interfere with normal roadway traffic. Vehicles shall not park or stop except within designated work areas. Personal vehicles will not be permitted to park within the state right-of-way. The contractor's vehicles will be prohibited from crossing the roadway and all pedestrian movement of the contractor's personnel on the roadway will be limited to within the closed work areas.

### **TRUCK MOUNTED ATTENUATOR**

Any lane or shoulder closure will include the use of a Truck Mounted Attenuator placed between oncoming traffic and equipment or vehicles.

## **LAW ENFORCEMENT OFFICER**

Law enforcement officers will be required to be furnished on the project at any time the traffic is reduced to one lane. The contractor will be required to establish an agreement with a local law enforcement agency to provide an officer and police cruiser to be used to warn traffic on lane closures and stopped traffic ahead. The contractor will be responsible to reimburse the agency of the cost for this service. This requirement is solely for the intent of warning traffic of a potential danger ahead and not for the purpose of issuance of traffic violations. The officer should however have the authority to issue citations if necessary and at his discretion. Patrolling for speeding and issuance of double fines citations should be performed by a separate officer and the contractor will not be required to reimburse the agency for that operation. **No direct payment will be made** for the providing of law enforcement officers and will be consider **incidental** to "Maintain and Control Traffic".

## **MISC.**

The Contractor shall reduce the speed limit to **55 MPH** in areas signed for 70 MPH in and approaching the work zones unless otherwise noted.

The use of Double Fine Zones may be used at the Contractor's discretion.

The Engineer may elect to use Variable Message Boards when necessary.

## **118B00063L&R**

Maintain a 12'-0" usable lane each direction on I-75. Single lane closures and shoulder closures may be used. All lane closures will be permitted between the hours 6:00 PM and 7:00 AM. All lane closures must be removed when not working. In addition to Section 108.09 of the KYTC Standard Specification the contractor will be assessed a liquidated damage of **\$1,000.00** per hour and **\$5,000.00** per hour for any hours after the 1<sup>st</sup> hour for any lane closure other than the allowed closure times. No lane closures will be permitted on Nationally Recognized Holidays and Weekends associated with these Holidays. The Project Engineer may also restrict weekend lane closures on Special Events such as Bristol and Kentucky Speedway Race Weekends. The Project Engineer will notify the contractor in writing at least 1 week in advance of any lane closure restrictions.

## **MEASUREMENT.**

**A. Maintain and Control Traffic:** The Department will measure the quantity as "Lump Sum".

**B. Portable Changeable Message Sign:** The Department will measure the quantity for "Each".

## **PAYMENT.**

**A. Maintain and Control Traffic (02650):** Payment of the contract lump sum amount for "maintain and control traffic" shall be full compensation to furnish, install, maintain and remove all items necessary to maintain and control traffic as specified for this contract. All traffic control items shall remain the property of the contractor when the work is complete.

**B. Portable Changeable Message Sign (02671):** Payment at "each" shall be full compensation to furnish, install, maintain and remove all portable changeable message signs as specified.

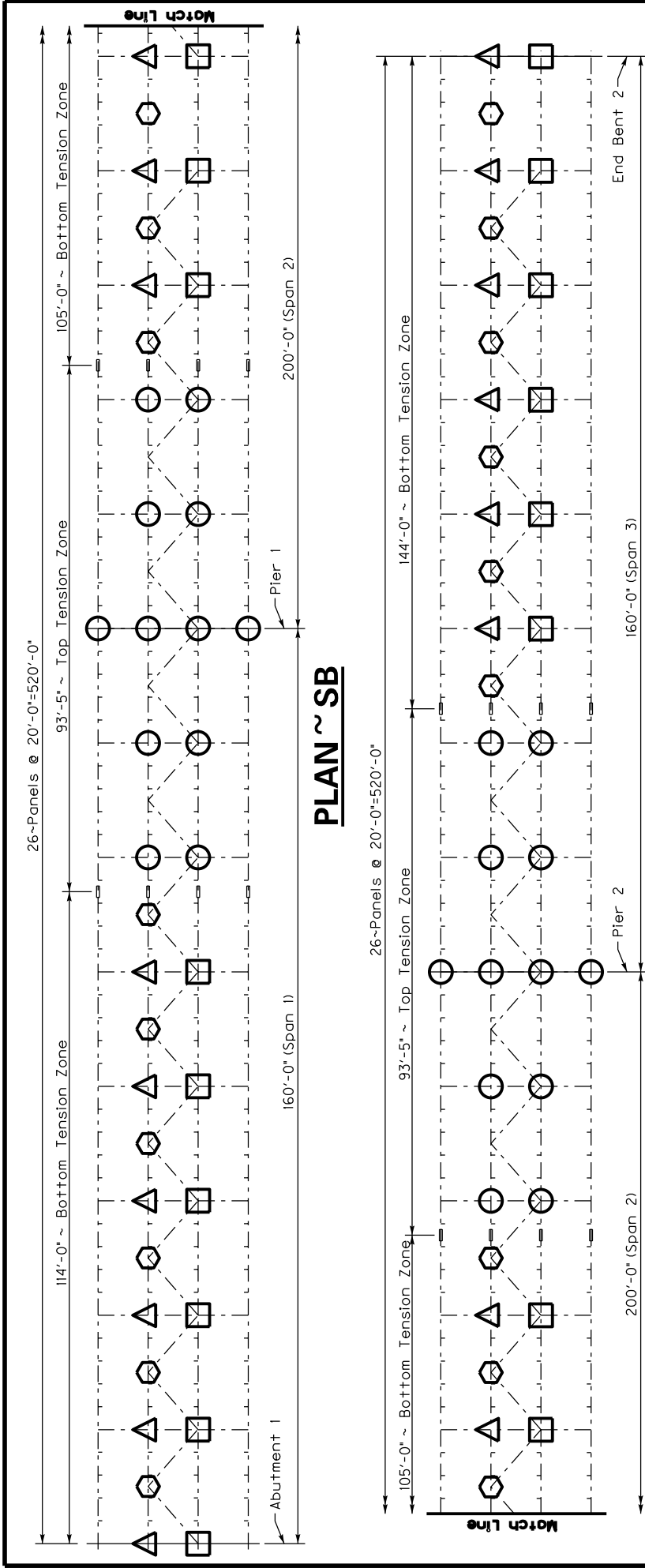

| LEGEND |   |
|--------|---|
| □      | STEEL REPAIR ~ TYPE B on one side of Girder and                   |
| □      | STEEL REPAIR TYPE A on other side of Girder (Bottom Tension Zone) |
| ○      | STEEL REPAIR ~ TYPE B   |
| △      | STEEL REPAIR ~ TYPE A (Bottom Tension Zone)                       |
| ○      | STEEL REPAIR ~ TYPE A (Top Tension Zone)                          |

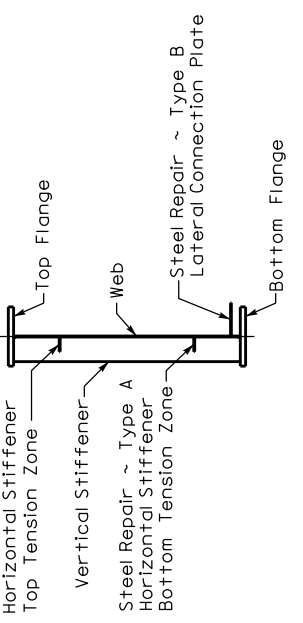

**118B00063L**

|  |  |
|--|--|
| Commonwealth of Kentucky<br>DEPARTMENT OF HIGHWAYS                   |  |
| COUNTY<br><b>WHITLEY</b>   |  |
| <b>SOUTHBOUND STEEL REPAIRS</b>                                      |  |
| PREPARED BY<br>Division of Maintenance<br>Bridge Preservation Branch |  |

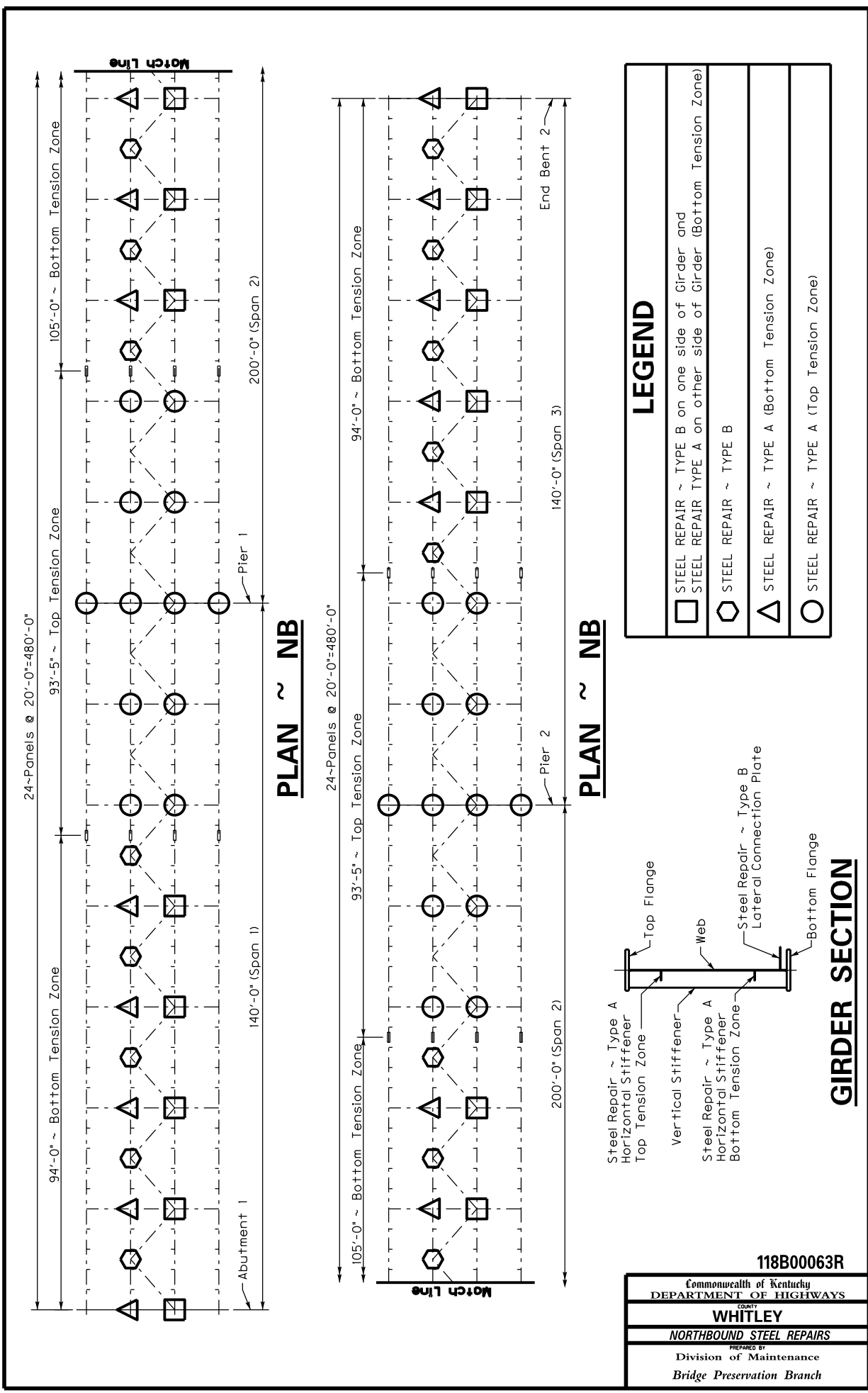

**118B00063R**

Commonwealth of Kentucky  
 DEPARTMENT OF HIGHWAYS

COUNTY  
**WHITLEY**

**NORTHBOUND STEEL REPAIRS**

PREPARED BY  
 Division of Maintenance  
 Bridge Preservation Branch

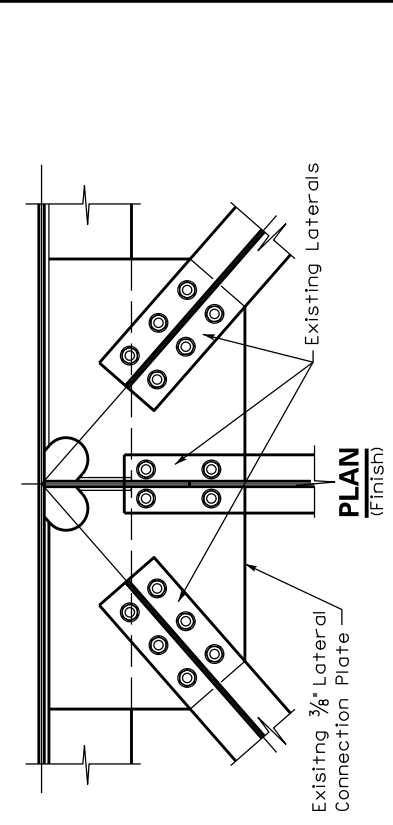
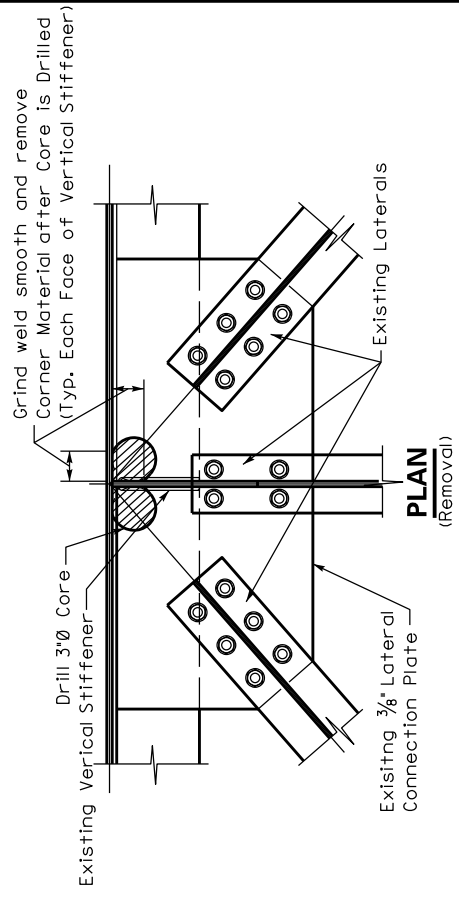

**STEEL REPAIR ~ TYPE B**  
(Lateral Connection)

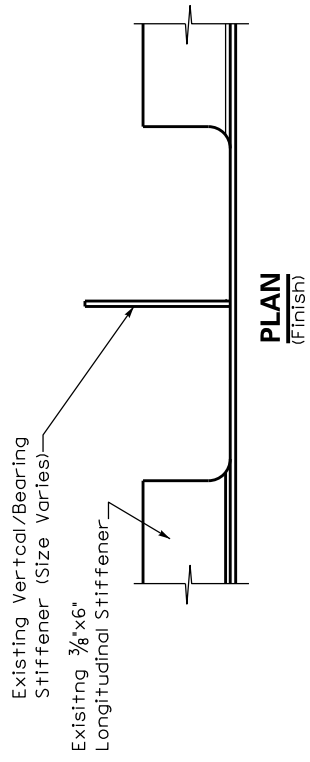
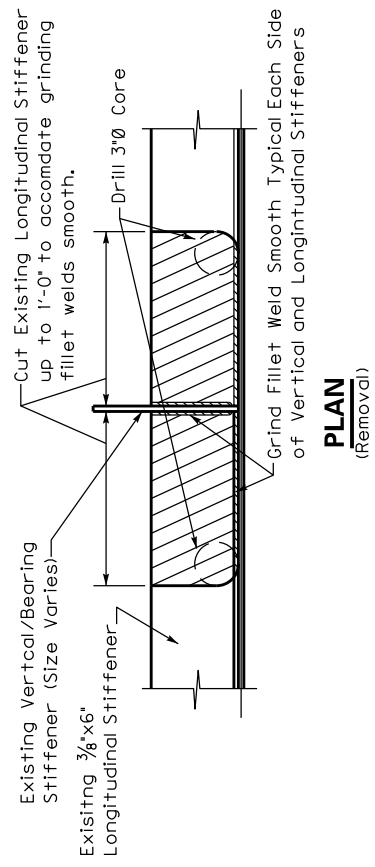

**STEEL REPAIR ~ TYPE A**  
(Typical Bottom and Top Tension Zones)

**QUANTITIES**

|               |                         |                         |
|---------------|-------------------------|-------------------------|
|               | STEEL REPAIR ~ TYPE "A" | STEEL REPAIR ~ TYPE "B" |
| 118B00063L SB | 58                      | 35                      |
| 118B00063R NB | 54                      | 31                      |

118B00063L  
118B00063R

Commonwealth of Kentucky  
DEPARTMENT OF HIGHWAYS  
COUNTY  
**WHITLEY**  
STEEL REPAIR DETAILS  
PREPARED BY  
Division of Maintenance  
Bridge Preservation Branch



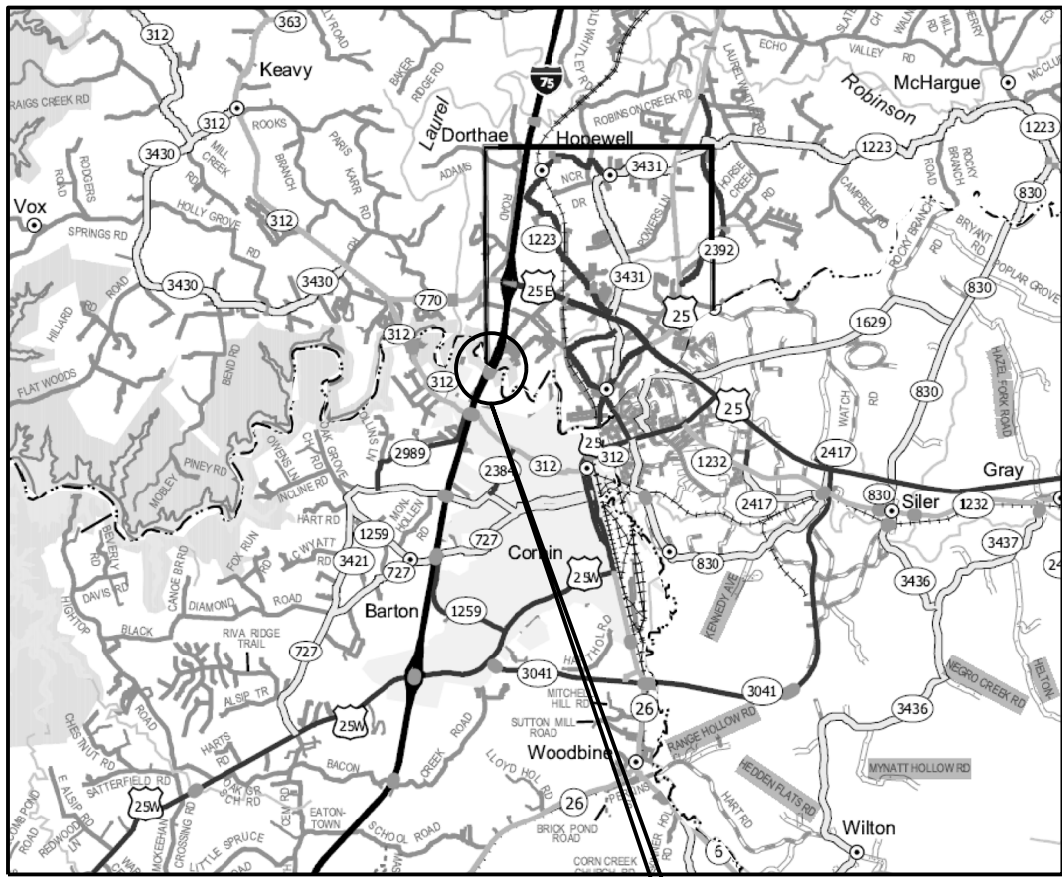

FE02 118 0075 B00063L&R  
I-75 over Lynn Camp Creek

### LOCATION MAP

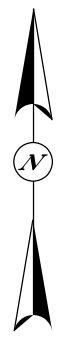
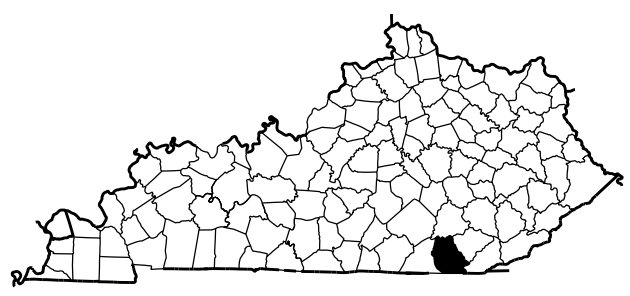

118B00063L  
118B00063R

|  |
|--|
| Commonwealth of Kentucky<br>DEPARTMENT OF HIGHWAYS                   |
| COUNTY<br><b>WHITLEY</b>   |
| <b>LOCATION MAP</b>  |
| PREPARED BY<br>Division of Maintenance<br>Bridge Preservation Branch |

**PART II**  
**SPECIFICATIONS AND STANDARD DRAWINGS**

### **SPECIFICATIONS REFERENCE**

Any reference in the plans or proposal to previous editions of the *Standard Specifications for Road and Bridge Construction* and *Standard Drawings* are superseded by *Standard Specifications for Road and Bridge Construction, Edition of 2019* and *Standard Drawings, Edition of 2016*.

## **SUPPLEMENTAL SPECIFICATIONS**

The contractor shall use the Supplemental Specifications that are effective at the time of letting.  
The Supplemental Specifications can be found at the following link:

<http://transportation.ky.gov/Construction/Pages/Kentucky-Standard-Specifications.aspx>

**PART III**

**EMPLOYMENT, WAGE AND RECORD REQUIREMENTS**

**TRANSPORTATION CABINET  
DEPARTMENT OF HIGHWAYS**

**LABOR AND WAGE REQUIREMENTS  
APPLICABLE TO OTHER THAN FEDERAL-AID SYSTEM PROJECTS**

- I. Application
- II. Nondiscrimination of Employees (KRS 344)

**I. APPLICATION**

1. These contract provisions shall apply to all work performed on the contract by the contractor with his own organization and with the assistance of workmen under his immediate superintendence and to all work performed on the contract by piecework, station work or by subcontract. The contractor's organization shall be construed to include only workmen employed and paid directly by the contractor and equipment owned or rented by him, with or without operators.

2. The contractor shall insert in each of his subcontracts all of the stipulations contained in these Required Provisions and such other stipulations as may be required.

3. A breach of any of the stipulations contained in these Required Provisions may be grounds for termination of the contract.

3. If the contractor is in control of apprenticeship or other training or retraining, including on-the-job training programs, he shall not discriminate against an individual because of his race, color, religion, national origin, sex, disability or age forty (40) and over, in admission to, or employment in any program established to provide apprenticeship or other training.

4. The contractor will send to each labor union or representative of workers with which he has a collective bargaining agreement or other contract or understanding, a notice to be provided advising the said labor union or workers' representative of the contractor's commitments under this section, and shall post copies of the notice in conspicuous places available to employees and applicants for employment. The contractor will take such action with respect to any subcontract or purchase order as the administrating agency may direct as a means of enforcing such provisions, including sanctions for non-compliance.

Revised: January 25, 2017

**II. NONDISCRIMINATION OF EMPLOYEES**

**AN ACT OF THE KENTUCKY  
GENERAL ASSEMBLY TO PREVENT  
DISCRIMINATION IN EMPLOYMENT  
KRS CHAPTER 344  
EFFECTIVE JUNE 16, 1972**

The contract on this project, in accordance with KRS Chapter 344, provides that during the performance of this contract, the contractor agrees as follows:

1. The contractor shall not fail or refuse to hire, or shall not discharge any individual, or otherwise discriminate against an individual with respect to his compensation, terms, conditions, or privileges of employment, because of such individual's race, color, religion, national origin, sex, disability or age (forty and above); or limit, segregate, or classify his employees in any way which would deprive or tend to deprive an individual of employment opportunities or otherwise adversely affect his status as an employee, because of such individual's race, color, religion, national origin, sex, disability or age forty (40) and over. The contractor agrees to post in conspicuous places, available to employees and applicants for employment, notices to be provided setting forth the provisions of this nondiscrimination clause.

2. The contractor shall not print or publish or cause to be printed or published a notice or advertisement relating to employment by such an employer or membership in or any classification or referral for employment by the employment agency, indicating any preference, limitation, specification, or discrimination, based on race, color, religion, national origin, sex, or age forty (40) and over, or because the person is a qualified individual with a disability, except that such a notice or advertisement may indicate a preference, limitation, or specification based on religion, national origin, sex, or age forty (40) and over, or because the person is a qualified individual with a disability, when religion, national origin, sex, or age forty (40) and over, or because the person is a qualified individual with a disability, is a bona fide occupational qualification for employment.

## EXECUTIVE BRANCH CODE OF ETHICS

In the 1992 regular legislative session, the General Assembly passed and Governor Brereton Jones signed Senate Bill 63 (codified as KRS 11A), the Executive Branch Code of Ethics, which states, in part:

KRS 11A.040 (7) provides:

No present or former public servant shall, within six (6) months following termination of his office or employment, accept employment, compensation, or other economic benefit from any person or business that contracts or does business with, or is regulated by, the state in matters in which he was directly involved during the last thirty-six (36) months of his tenure. This provision shall not prohibit an individual from returning to the same business, firm, occupation, or profession in which he was involved prior to taking office or beginning his term of employment, or for which he received, prior to his state employment, a professional degree or license, provided that, for a period of six (6) months, he personally refrains from working on any matter in which he was directly involved during the last thirty-six (36) months of his tenure in state government. This subsection shall not prohibit the performance of ministerial functions, including but not limited to filing tax returns, filing applications for permits or licenses, or filing incorporation papers, nor shall it prohibit the former officer or public servant from receiving public funds disbursed through entitlement programs.

KRS 11A.040 (9) states:

A former public servant shall not represent a person or business before a state agency in a matter in which the former public servant was directly involved during the last thirty-six (36) months of his tenure, for a period of one (1) year after the latter of:

- a) The date of leaving office or termination of employment; or
- b) The date the term of office expires to which the public servant was elected.

This law is intended to promote public confidence in the integrity of state government and to declare as public policy the idea that state employees should view their work as a public trust and not as a way to obtain private benefits.

If you have worked for the executive branch of state government within the past six months, you may be subject to the law's prohibitions. The law's applicability may be different if you hold elected office or are contemplating representation of another before a state agency.

Also, if you are affiliated with a firm which does business with the state and which employs former state executive-branch employees, you should be aware that the law may apply to them.

In case of doubt, the law permits you to request an advisory opinion from the Executive Branch Ethics Commission, 3 Fountain Place, Frankfort, Kentucky 40601; telephone (502) 564-7954.

Revised: January 27, 2017

### **Kentucky Equal Employment Opportunity Act of 1978**

The requirements of the Kentucky Equal Employment Opportunity Act of 1978 (KRS 45.560-45.640) shall apply to this Contract. The apparent low Bidder will be required to submit EEO forms to the Division of Construction Procurement, which will then forward to the Finance and Administration Cabinet for review and approval. No award will become effective until all forms are submitted and EEO/CC has certified compliance. The required EEO forms are as follows:

- EEO-1: Employer Information Report
- Affidavit of Intent to Comply
- Employee Data Sheet
- Subcontractor Report

These forms are available on the Finance and Administration's web page under ***Vendor Information, Standard Attachments and General Terms*** at the following address:  
**<https://www.eProcurement.ky.gov>**.

Bidders currently certified as being in compliance by the Finance and Administration Cabinet may submit a copy of their approval letter in lieu of the referenced EEO forms.

For questions or assistance please contact the Finance and Administration Cabinet by email at **[finance.contractcompliance@ky.gov](mailto:finance.contractcompliance@ky.gov)** or by phone at 502-564-2874.



# EMPLOYEE RIGHTS UNDER THE FAIR LABOR STANDARDS ACT

THE UNITED STATES DEPARTMENT OF LABOR WAGE AND HOUR DIVISION

## FEDERAL MINIMUM WAGE

# \$7.25 PER HOUR

BEGINNING JULY 24, 2009

**OVERTIME PAY** At least 1½ times your regular rate of pay for all hours worked over 40 in a workweek.

**CHILD LABOR** An employee must be at least **16** years old to work in most non-farm jobs and at least **18** to work in non-farm jobs declared hazardous by the Secretary of Labor.

Youths **14** and **15** years old may work outside school hours in various non-manufacturing, non-mining, non-hazardous jobs under the following conditions:

**No more than**

- **3** hours on a school day or **18** hours in a school week;
- **8** hours on a non-school day or **40** hours in a non-school week.

Also, work may not begin before **7 a.m.** or end after **7 p.m.**, except from June 1 through Labor Day, when evening hours are extended to **9 p.m.** Different rules apply in agricultural employment.

**TIP CREDIT** Employers of “tipped employees” must pay a cash wage of at least \$2.13 per hour if they claim a tip credit against their minimum wage obligation. If an employee’s tips combined with the employer’s cash wage of at least \$2.13 per hour do not equal the minimum hourly wage, the employer must make up the difference. Certain other conditions must also be met.

**ENFORCEMENT** The Department of Labor may recover back wages either administratively or through court action, for the employees that have been underpaid in violation of the law. Violations may result in civil or criminal action.

Employers may be assessed civil money penalties of up to \$1,100 for each willful or repeated violation of the minimum wage or overtime pay provisions of the law and up to \$11,000 for each employee who is the subject of a violation of the Act’s child labor provisions. In addition, a civil money penalty of up to \$50,000 may be assessed for each child labor violation that causes the death or serious injury of any minor employee, and such assessments may be doubled, up to \$100,000, when the violations are determined to be willful or repeated. The law also prohibits discriminating against or discharging workers who file a complaint or participate in any proceeding under the Act.

### ADDITIONAL INFORMATION

- Certain occupations and establishments are exempt from the minimum wage and/or overtime pay provisions.
- Special provisions apply to workers in American Samoa and the Commonwealth of the Northern Mariana Islands.
- Some state laws provide greater employee protections; employers must comply with both.
- The law requires employers to display this poster where employees can readily see it.
- Employees under 20 years of age may be paid \$4.25 per hour during their first 90 consecutive calendar days of employment with an employer.
- Certain full-time students, student learners, apprentices, and workers with disabilities may be paid less than the minimum wage under special certificates issued by the Department of Labor.

For additional information:



# 1-866-4-USWAGE

(1-866-487-9243)

TTY: 1-877-889-5627



# WWW.WAGEHOUR.DOL.GOV

**PART IV**  
**INSURANCE**

Refer to  
*Kentucky Standard Specifications for Road and Bridge Construction,*  
current edition

**PART V**  
**BID ITEMS**

### PROPOSAL BID ITEMS

202902

Page 1 of 1

Report Date 1/24/20

#### Section: 0001 - BRIDGE

| LINE | BID CODE | ALT | DESCRIPTION   | QUANTITY | UNIT | UNIT PRIC | FP | AMOUNT |
|------|----------|-----|---|----------|------|-----------|----|--------|
| 0010 | 02650    |     | MAINTAIN & CONTROL TRAFFIC<br>APPLIES TO 118B00063L       | 1.00     | LS   |           | \$ |        |
| 0020 | 02650    |     | MAINTAIN & CONTROL TRAFFIC<br>APPLIES TO 118B00063R       | 1.00     | LS   |           | \$ |        |
| 0030 | 02671    |     | PORTABLE CHANGEABLE MESSAGE SIGN<br>APPLIES TO 118B00063L | 2.00     | EACH |           | \$ |        |
| 0040 | 02671    |     | PORTABLE CHANGEABLE MESSAGE SIGN<br>APPLIES TO 118B00063R | 2.00     | EACH |           | \$ |        |
| 0050 | 24879EC  |     | STEEL REPAIR<br>TYPE A<br>APPLIES TO 118B00063L           | 54.00    | EACH |           | \$ |        |
| 0060 | 24879EC  |     | STEEL REPAIR<br>TYPE A<br>APPLIES TO 118B00063R           | 58.00    | EACH |           | \$ |        |
| 0070 | 24879EC  |     | STEEL REPAIR<br>TYPE B<br>APPLIES TO 118B00063L           | 66.00    | EACH |           | \$ |        |

#### Section: 0002 - DEMOBILIZATION

| LINE | BID CODE | ALT | DESCRIPTION    | QUANTITY | UNIT | UNIT PRIC | FP | AMOUNT |
|------|----------|-----|----------------|----------|------|-----------|----|--------|
| 0080 | 02569    |     | DEMOBILIZATION | 1.00     | LS   |           | \$ |        |