



CALL NO. 302

CONTRACT ID. 191025

HARDIN COUNTY

FED/STATE PROJECT NUMBER JP02 047 0361 000-001

DESCRIPTION CARDINAL DRIVE(KY-361)

WORK TYPE ASPHALT SURFACE WITH GRADE & DRAIN

PRIMARY COMPLETION DATE 7/1/2020

LETTING DATE: May 24,2019

Sealed Bids will be received electronically through the Bid Express bidding service until 10:00 AM EASTERN DAYLIGHT TIME May 24,2019. Bids will be publicly announced at 10:00 AM EASTERN DAYLIGHT TIME.

PLANS AVAILABLE FOR THIS PROJECT.

REQUIRED BID PROPOSAL GUARANTY: Not less than 5% of the total bid.

TABLE OF CONTENTS

PART I	SCOPE OF WORK
	<ul style="list-style-type: none">• PROJECT(S), COMPLETION DATE(S), & LIQUIDATED DAMAGES• CONTRACT NOTES• STATE CONTRACT NOTES• ASPHALT MIXTURE• INCIDENTAL SURFACING• ASPHALT PAVEMENT RIDE QUALITY CAT B• COMPACTION OPTION A• SPECIAL NOTE(S) APPLICABLE TO PROJECT• SPECIAL NOTE FOR PIPELINE INSPECTION• RIGHT OF WAY NOTES• UTILITY IMPACT & RAIL CERTIFICATION NOTES• GENERAL UTILITY NOTES• GAS STANDARD UTILITY BID ITEMS• GASLINE SPECS• SEWER STANDARD UTILITY BID ITEMS• SEWERLINE SPECS• KPDES STORM WATER PERMIT, BMP AND ENOI• COMMUNICATING ALL PROMISES
PART II	SPECIFICATIONS AND STANDARD DRAWINGS
	<ul style="list-style-type: none">• SPECIFICATIONS REFERENCE• SUPPLEMENTAL SPECIFICATION• [SN-1I] PORTABLE CHANGEABLE SIGNS• [SN-11N] LONGITUDINAL PAVEMENT JOINT ADHESIVE
PART III	EMPLOYMENT, WAGE AND RECORD REQUIREMENTS
	<ul style="list-style-type: none">• LABOR AND WAGE REQUIREMENTS• EXECUTIVE BRANCH CODE OF ETHICS• KENTUCKY EQUAL EMPLOYMENT OPPORTUNITY ACT OF 1978 LOCALITY / STATE• PROJECT WAGE RATES / STATE
PART IV	INSURANCE
PART V	BID ITEMS

PART I
SCOPE OF WORK

ADMINISTRATIVE DISTRICT - 04

CONTRACT ID - 191025

JP02 047 0361 000-001

COUNTY - HARDIN

PCN - DE04703611925

JP02 047 0361 000-001

CARDINAL DRIVE(KY-361) RELOCATE INTERSECTION OF WOODLAND DRIVE AT US-31W, A DISTANCE OF 0.46 MILES.ASPHALT SURFACE WITH GRADE & DRAIN SYP NO. 04-07020.00.

GEOGRAPHIC COORDINATES LATITUDE 37:42:30.00 LONGITUDE 85:52:39.00

COMPLETION DATE(S):

COMPLETED BY 07/01/2020

APPLIES TO ENTIRE CONTRACT

CONTRACT NOTES

PROPOSAL ADDENDA

All addenda to this proposal must be applied when calculating bid and certified in the bid packet submitted to the Kentucky Department of Highways. Failure to use the correct and most recent addenda may result in the bid being rejected.

BID SUBMITTAL

Bidder must use the Department's electronic bidding software. The Bidder must download the bid file located on the Bid Express website (www.bidx.com) to prepare a bid packet for submission to the Department. The bidder must submit electronically using Bid Express.

JOINT VENTURE BIDDING

Joint venture bidding is permissible. All companies in the joint venture must be prequalified in one of the work types in the Qualifications for Bidders for the project. The bidders must get a vendor ID for the joint venture from the Division of Construction Procurement and register the joint venture as a bidder on the project. Also, the joint venture must obtain a digital ID from Bid Express to submit a bid. A joint bid bond of 5% may be submitted for both companies or each company may submit a separate bond of 5%.

UNDERGROUND FACILITY DAMAGE PROTECTION

The contractor shall make every effort to protect underground facilities from damage as prescribed in the Underground Facility Damage Protection Act of 1994, Kentucky Revised Statute KRS 367.4901 to 367.4917. It is the contractor's responsibility to determine and take steps necessary to be in compliance with federal and state damage prevention directives. When prescribed in said directives, the contractor shall submit Excavation Locate Requests to the Kentucky Contact Center (KY811) via web ticket entry. The submission of this request does not relieve the contractor from the responsibility of contacting non-member facility owners, whom shall be contacted through their individual Protection Notification Center. Non-compliance with these directives can result in the enforcement of penalties.

REGISTRATION WITH THE SECRETARY OF STATE BY A FOREIGN ENTITY

Pursuant to KRS 176.085(1)(b), an agency, department, office, or political subdivision of the Commonwealth of Kentucky shall not award a state contract to a person that is a foreign entity required by [KRS 14A.9-010](#) to obtain a certificate of authority to transact business in the Commonwealth ("certificate") from the Secretary of State under [KRS 14A.9-030](#) unless the person produces the certificate within fourteen (14) days of the bid or proposal opening. If the foreign entity is not required to obtain a certificate as provided in [KRS 14A.9-010](#), the foreign entity should identify the applicable exception. Foreign entity is defined within [KRS 14A.1-070](#).

For all foreign entities required to obtain a certificate of authority to transact business in the Commonwealth, if a copy of the certificate is not received by the contracting agency within the time frame identified above, the foreign entity's solicitation response shall be deemed non-responsive or the awarded contract shall be cancelled.

Businesses can register with the Secretary of State at <https://secure.kentucky.gov/sos/ftbr/welcome.aspx>.

SPECIAL NOTE FOR PROJECT QUESTIONS DURING ADVERTISEMENT

Questions about projects during the advertisement should be submitted in writing to the Division of Construction Procurement. This may be done by fax (502) 564-7299 or email to kyc.projectquestions@ky.gov. The Department will attempt to answer all submitted questions. The Department reserves the right not to answer if the question is not pertinent or does not aid in clarifying the project intent.

The deadline for posting answers will be 3:00 pm Eastern Daylight Time, the day preceding the Letting. Questions may be submitted until this deadline with the understanding that the later a question is submitted, the less likely an answer will be able to be provided.

The questions and answers will be posted for each Letting under the heading "Questions & Answers" on the Construction Procurement website (www.transportation.ky.gov/contract). The answers provided shall be considered part of this Special Note and, in case of a discrepancy, will govern over all other bidding documents.

HARDWOOD REMOVAL RESTRICTIONS

The US Department of Agriculture has imposed a quarantine in Kentucky and several surrounding states, to prevent the spread of an invasive insect, the emerald ash borer. Hardwood cut in conjunction with the project may not be removed from the state. Chipping or burning on site is the preferred method of disposal.

INSTRUCTIONS FOR EXCESS MATERIAL SITES AND BORROW SITES

Identification of excess material sites and borrow sites shall be the responsibility of the Contractor. The Contractor shall be responsible for compliance with all applicable state and federal laws and may wish to consult with the US Fish and Wildlife Service to seek protection under Section 10 of the Endangered Species Act for these activities.

ACCESS TO RECORDS

The contractor, as defined in KRS 45A.030 (9) agrees that the contracting agency, the Finance and Administration Cabinet, the Auditor of Public Accounts, and the Legislative Research Commission, or their duly authorized representatives, shall have access to any books, documents, papers, records, or other evidence, which are directly pertinent to this contract for the purpose of financial audit or program review. Records and other prequalification information confidentially

disclosed as part of the bid process shall not be deemed as directly pertinent to the contract and shall be exempt from disclosure as provided in KRS 61.878(1)(c). The contractor also recognizes that any books, documents, papers, records, or other evidence, received during a financial audit or program review shall be subject to the Kentucky Open Records Act, KRS 61.870 to 61.884.

In the event of a dispute between the contractor and the contracting agency, Attorney General, or the Auditor of Public Accounts over documents that are eligible for production and review, the Finance and Administration Cabinet shall review the dispute and issue a determination, in accordance with Secretary's Order 11-004.

April 30, 2018

SPECIAL NOTE FOR RECIPROCAL PREFERENCE

RECIPROCAL PREFERENCE TO BE GIVEN BY PUBLIC AGENCIES TO RESIDENT BIDDERS

By reference, KRS 45A.490 to 45A.494 are incorporated herein and in compliance regarding the bidders residency. Bidders who want to claim resident bidder status should complete the Affidavit for Claiming Resident Bidder Status along with their bid in the electronic bidding software. Submittal of the Affidavit should be done along the bid in Bid Express.

April 30, 2018

ASPHALT MIXTURE

Unless otherwise noted, the Department estimates the rate of application for all asphalt mixtures to be 110 lbs/sy per inch of depth.

INCIDENTAL SURFACING

The Department has included in the quantities of asphalt mixtures established in the proposal estimated quantities required for resurfacing or surfacing mailbox turnouts, farm field entrances, residential and commercial entrances, curve widening, ramp gores and tapers, and road and street approaches, as applicable. Pave these areas to the limits as shown on Standard Drawing RPM-110-06 or as directed by the Engineer. In the event signal detectors are present in the intersecting streets or roads, pave the crossroads to the right of way limit or back of the signal detector, whichever is the farthest back of the mainline. Surface or resurface these areas as directed by the Engineer. The Department will not measure placing and compacting for separate payment but shall be incidental to the Contract unit price for the asphalt mixtures.

ASPHALT PAVEMENT RIDE QUALITY CATEGORY B

The Department will apply Pavement Rideability Requirements on this project in accordance with Section 410, Category B.

OPTION A

Be advised that the Department will accept compaction of asphalt mixtures furnished for driving lanes and ramps, at 1 inch (25mm) or greater, on this project according to OPTION A in accordance with Section 402 and Section 403 of the current Standard Specifications. The Department will require joint cores as described in Section 402.03.02 for surface mixtures only. The Department will accept compaction of all other asphalt mixtures according to OPTION B.

SPECIAL NOTE FOR INLAID PAVEMENT MARKERS

I. DESCRIPTION

Except as provided herein, perform all work in accordance with the Department's Standard and Supplemental Specifications and applicable Standard and Sepia Drawings, current editions. Article references are to the Standard Specifications. This work shall consist of:

- (1) Maintain and Control Traffic; and (2) Furnish and install Inlaid Pavement Markers (IPMs) in recessed grooves; and (3) Any other work as specified by these notes and the Contract.

II. MATERIALS

The Department will sample all materials in accordance with the Department's Sampling Manual. Make the materials available for sampling a sufficient time in advance of the use of the materials to allow for the necessary time for testing unless otherwise specified in these Notes.

- A. Maintain and Control Traffic.** See the Traffic Control Plan.
- B. Markers.** Provide reflective lenses with depth control breakaway positioning tabs. Before furnishing the markers, provide to the Engineer the manufacturer's current recommendations for adhesives and installation procedures. Use one brand and design throughout the project. Use markers meeting the specifications in the table below.

SPECIFICATIONS FOR HOUSING AND REFLECTOR	
Material:	Polycarbonate Plastic
Weight:	Housing 2.00 oz.
	Reflector 2.00oz.
Housing Size:	5.00" x 3.00" x 0.70" high
Specific Intensity of Reflectivity at 0.2° Observation Angle	
White:	3.0 at 0°entrance angle
	1.2 at 20°entrance angle
Yellow:	60% of white values
Red:	25% of white values

- C. Adhesives.** Use adhesives that conform to the manufacturer's recommendations.

Inlaid Pavement Markers
Page 2 of 4

III. CONSTRUCTION

- A. Experimental Evaluation.** The University of Kentucky Transportation Center will be evaluating this installation of IPMs. Notify the Engineer a minimum of 14 calendar days prior to beginning work. The Engineer will coordinate the University's activities with the Contractor's work.
- B. Maintain and Control Traffic.** See the Traffic Control Plan.
- C. Installation.** Install IPMs in recessed grooves cut into the final course of asphalt pavement according to the manufacturer's recommendations. Do not cut the grooves until the pavement has cured sufficiently to prevent tearing or raveling. Cut installation grooves using diamond blades on saws that accurately control groove dimensions. Remove all dirt, grease, oil, loose or unsound layers, and any other material from the marker area which would reduce the bond of the adhesive. Maintain pavement surfaces in a clean condition until placing markers.

Prepare the pavement surfaces, and install the markers in the recessed groove according to the drawing below. Use an approved snowplowable epoxy adhesive. Ensure that the adhesive bed area is equal to the bottom area of the marker, and apply adhesive in sufficient quantity to force excess out around the entire perimeter of the marker. Use materials, equipment, and construction procedures that ensure proper adhesion of the markers to the pavement surface according to the manufacturer's recommendations. Remove all excess adhesive from in front of the reflective faces. If any adhesive or foreign matter cannot be removed from the reflective faces, or if any marker fails to properly adhere to the pavement surface, remove and replace the marker at no additional cost to the Department.

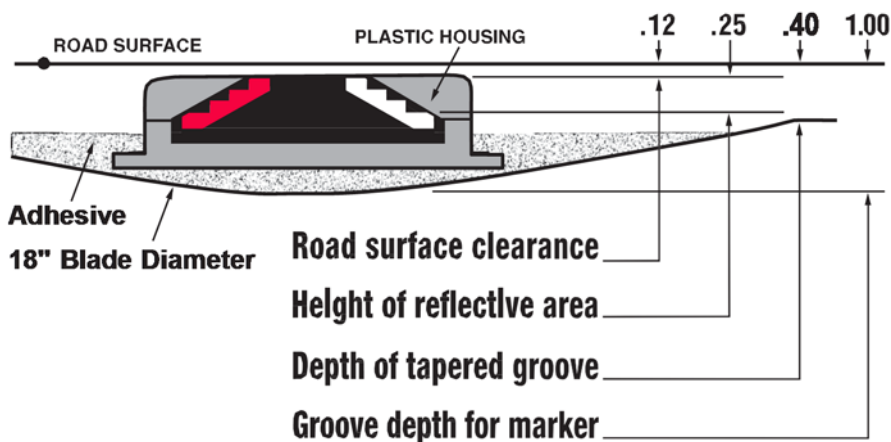

- D. Location and Spacing.** Install the markers in the pattern for high reflectivity with two (2) IPMs per groove. Locate and space markers as shown in the current Standard Drawings or Sepias. (Note: use Inlaid Pavement Markers wherever Type V Pavement

Inlaid Pavement Markers
 Page 3 of 4

Markers are called for.) Do not install markers on bridge decks. Do not install a marker on top of a pavement joint or crack. Offset the recessed groove a minimum of 2 inches from any longitudinal pavement joint or crack and at least one inch from the painted stripe, ensuring that the finished line of markers is straight with minimal lateral deviation. Give preference to maintaining the 2-inch offset between recessed groove and joint as opposed to keeping the line of markers straight.

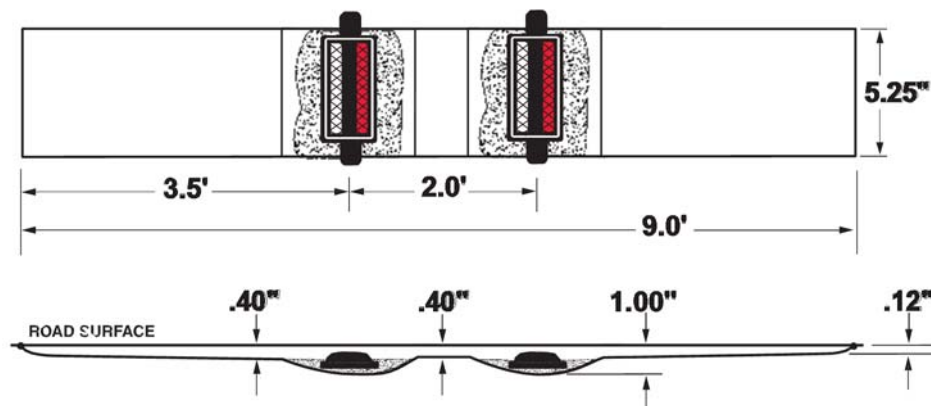

Place inlaid markers as much in line with existing pavement striping as possible. Place markers installed along an edge line or channelizing line so that the near edge of the plastic housing is no more than one inch from the near edge of the line. Place markers installed along a lane line between and in line with the dashes. Do not place markers over the lines except where the lines deviate visibly from their correct alignment, and then only after obtaining the Engineer's prior approval of the location.

If conflicts between recessed groove placement in relation to pavement joint and striping cannot be resolved, obtain the Engineer's approval to eliminate the marker or revise the alignment.

- E. Disposal of Waste.** Dispose of all removed asphalt pavement, debris, and other waste at sites off the right of way obtained by the Contractor at no additional cost to the Department. See the Special Provision for Waste and Borrow Sites.
- F. Restoration.** Be responsible for all damage to public and/or private property resulting from the work. Restore all damaged features in like kind materials and design at no additional cost to the Department.
- G. On-Site Inspection.** Make a thorough inspection of the site prior to submitting a bid and be thoroughly familiar with existing conditions so that the work can be expeditiously performed after a contract is awarded. The Department will consider submission of a bid as evidence of this inspection having been made and will not honor any claims for money or grant Contract time extensions resulting from site conditions.

Inlaid Pavement Markers
Page 4 of 4

- H. Caution.** Do not take information shown on the drawings and in this proposal and the types and quantities of work listed as an accurate or complete evaluation of the material and conditions to be encountered during construction, but consider the types and quantities of work listed as approximate only. The bidder must draw his or her own conclusion as to the conditions encountered. The Department does not give any guarantee as to the accuracy of the data and no claim will be considered for additional compensation or extension of Contract time if the conditions encountered are not in accordance with the information shown.

IV. MEASUREMENT

- A. Maintain and Control Traffic.** See the Traffic Control Plan.
- B. Inlaid Pavement Markers.** The Department shall measure as Each. One (1) installation of "INLAID PAVEMENT MARKER" will consist of grooving the pavement, removing asphalt cuttings and debris, preheating pavement to remove moisture, adhesives, and installation of two (2) markers with all lenses in accordance with this note.

Note: Each pay item of Inlaid Pavement Marker will require two markers.

V. PAYMENT

- A. Maintain and Control Traffic.** See the Traffic Control Plan.
- B. Inlaid Pavement Markers.** The Department will make payment for the completed and accepted quantities of completely installed "INLAID PAVEMENT MARKERS" at the Contract unit price, Each. Accept payment as full compensation for all labor, equipment, materials, and incidentals necessary to accomplish this work to the satisfaction of the Engineer. A system of one (1) groove and two (2) markers shall be paid as one "INLAID PAVEMENT MARKER". The bid item "INLAID PAVEMENT MARKER" shall be used regardless of the color and type of lenses required.

SPECIAL NOTE FOR PIPELINE INSPECTION

1.0 DESCRIPTION. The Department will perform visual inspections on all pipe on the project. A video inspection will be required on projects having more than 250 linear feet of storm sewer and/or culvert pipe and on routes with an ADT of greater than 1,000 vehicles. Conduct video inspections on all pipe located under the roadway and 50 percent of the remaining pipe not under the roadway. Storm sewer runs and outfall pipes not under the roadway take precedence over rural entrance pipes. Contractors performing this item of work must be prequalified with the Department in the work type J51 (Video Pipe Inspection and Cleaning). Deflection testing shall be completed using a mandrel in accordance with the procedure outlined below or by physical measurement for pipes greater than 36 inches in diameter. Mandrel testing for deflection must be completed prior to the video inspection testing. Unless otherwise noted, Section references herein are to the Department's 2012 Standard Specifications for Road and Bridge Construction.

2.0 VIDEO INSPECTION. Ensure pipe is clear of water, debris or obstructions. Complete the video inspection and any necessary measurement prior to placing the final surface over any pipe. When paving will not be delayed, take measurements 30 days or more after the completion of earthwork to within 1 foot of the finished subgrade. Notify the Engineer a minimum of 24 hours in advance of inspection and notify the Engineer immediately if distresses or locations of improper installation are logged.

2.1 INSPECTION FOR DEFECTS AND DISTRESSES

A) Begin at the outlet end and proceed through to the inlet at a speed less than or equal to 30 ft/minute. Remove blockages that will prohibit a continuous operation.

B) Document locations of all observed defects and distresses including but not limited to: cracking, spalling, slabbing, exposed reinforcing steel, sags, joint offsets, joint separations, deflections, improper joints/connections, blockages, leaks, rips, tears, buckling, deviation from line and grade, damaged coatings/paved inverts, and other anomalies not consistent with a properly installed pipe.

C) During the video inspection provide a continuous 360 degree pan of every pipe joint.

D) Identify and measure all cracks greater than 0.1" and joint separations greater than 0.5".

E) Video Inspections are conducted from junction to junction which defines a pipe run. A junction is defined as a headwall, drop box inlet, curb box inlet, manhole, buried junction, or other structure that disturbs the continuity of the pipe. Multiple pipe inspections may be conducted from a single set up location, but each pipe run must be on a separate video file and all locations are to be referenced from nearest junction relative to that pipe run.

F) Record and submit all data on the TC 64-765 and TC 64-766 forms.

3.0 MANDREL TESTING. Mandrel testing will be used for deflection testing. For use on Corrugated Metal Pipe, High Density Polyethylene Pipe, and Polyvinyl Chloride Pipe,

use a mandrel device with an odd number of legs (9 minimum) having a length not less than the outside diameter of the mandrel. The diameter of the mandrel at any point shall not be less than the diameter specified in Section 3.6. Mandrels can be a fixed size or a variable size.

3.1 Use a proving ring or other method recommended by the mandrel manufacturer to verify mandrel diameter prior to inspection. Provide verification documentation for each size mandrel to the Engineer.

3.2 All deflection measurements are to be based off of the AASHTO Nominal Diameters. Refer to the chart in section 3.6.

3.3 Begin by using a mandrel set to the 5.0% deflection limit. Place the mandrel in the inlet end of the pipe and pull through to the outlet end. If resistance is met prior to completing the entire run, record the maximum distance achieved from the inlet side, then remove the mandrel and continue the inspection from the outlet end of the pipe toward the inlet end. Record the maximum distance achieved from the outlet side.

3.4 If no resistance is met at 5.0% then the inspection is complete. If resistance occurred at 5.0% then repeat 3.1 and 3.2 with the mandrel set to the 10.0% deflection limit. If the deflection of entire pipe run cannot be verified with the mandrel then immediately notify the Engineer.

3.5 Care must be taken when using a mandrel in all pipe material types and lining/coating scenarios. Pipe damaged during the mandrel inspection will be video inspected to determine the extent of the damage. If the damaged pipe was video inspected prior to mandrel inspection then a new video inspection is warranted and supersedes the first video inspection. Immediately notify the Engineer of any damages incurred during the mandrel inspection and submit a revised video inspection report.

3.6 AASHTO Nominal Diameters and Maximum Deflection Limits.

Base Pipe Diameter (inches)	AASHTO Nominal Diameter (inches)	Max. Deflection Limit (inches)	
		5.0%	10.0%
15	14.76	14.02	13.28
18	17.72	16.83	15.95
24	23.62	22.44	21.26
30	29.53	28.05	26.58
36	35.43	33.66	31.89
42	41.34	39.27	37.21
48	47.24	44.88	42.52
54	53.15	50.49	47.84
60	59.06	56.11	53.15

4.0 PHYSICAL MEASUREMENT OF PIPE DEFLECTION. Alternate method for deflection testing when there is available access or the pipe is greater than 36 inches in diameter, as per 4.1. Use a contact or non-contact distance instrument. A leveling device is recommended for establishing or verifying vertical and horizontal control.

4.1 Physical measurements may be taken after installation and compared to the AASHTO Nominal Diameter of the pipe as per Section 3.6. When this method is used, determine the smallest interior diameter of the pipe as measured through the center point of the pipe (D2). All measurements are to be taken from the inside crest of the corrugation. Take the D2 measurements at the most deflected portion of the pipe run in question and at intervals no greater than ten (10) feet through the run. Calculate the deflection as follows:

$$\% \text{ Deflection} = [(AASHTO \text{ Nominal Diameter} - D2) / AASHTO \text{ Nominal Diameter}] \times 100\%$$

Note: The Engineer may require that preset monitoring points be established in the culvert prior to backfilling. For these points the pre-installation measured diameter (D1) is measured and recorded. Deflection may then be calculated from the following formula:

$$\% \text{ Deflection} = [(D1 - D2) / D1] (100\%)$$

4.2 Record and submit all data.

5.0 DEDUCTION SCHEDULE. All pipe deductions shall be handled in accordance with the tables shown below.

FLEXIBLE PIPE DEFLECTION	
Amount of Deflection (%)	Payment
0.0 to 5.0	100% of the Unit Bid Price
5.1 to 9.9	50% of the Unit Bid Price ⁽¹⁾
10 or greater	Remove and Replace ⁽²⁾

⁽¹⁾ Provide Structural Analysis for HDPE and metal pipe. Based on the structural analysis, pipe may be allowed to remain in place at the reduced unit price. ⁽²⁾ The Department may allow the pipe to remain in place with no pay to the Contractor in instances where it is in the best interest to the public and where the structural analysis demonstrates that the pipe should function adequately.

RIGID PIPE REMEDIATION TABLE PIPE	
Crack Width (inches)	Payment
• 0.1	100% of the Unit Bid Price
Greater than 0.1	Remediate or Replace ⁽¹⁾

⁽¹⁾ Provide the Department in writing a method for repairing the observed cracking. Do not begin work until the method has been approved.

6.0 PAYMENT. The Department will measure the quantity in linear feet of pipe to inspect. The Department will make payment for the completed and accepted quantities under the following:

<u>Code</u>	<u>Pay Item</u>	<u>Pay Unit</u>
24814EC	Pipeline Inspection	Linear Foot
10065NS	Pipe Deflection Deduction	Dollars

	KENTUCKY TRANSPORTATION CABINET Department of Highways DIVISION OF RIGHT OF WAY & UTILITIES RIGHT OF WAY CERTIFICATION	TC 62-226 Rev. 01/2016 Page 1 of 1
---	--	--

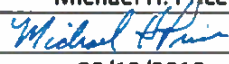
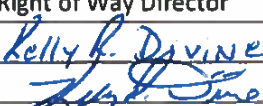
<input checked="" type="checkbox"/>	Original	<input type="checkbox"/>	Re-Certification	RIGHT OF WAY CERTIFICATION	
ITEM #		COUNTY		PROJECT # (STATE)	PROJECT # (FEDERAL)
04-7020		Hardin		13 HC JP02 047 65579 01R	
PROJECT DESCRIPTION					
Relocate Intersection of Woodland Drive at US-31W					
<input type="checkbox"/> No Additional Right of Way Required					
Construction will be within the limits of the existing right of way. The right of way was acquired in accordance to FHWA regulations under the Uniform Relocation Assistance and Real Property Acquisitions Policy Act of 1970, as amended. No additional right of way or relocation assistance were required for this project.					
<input checked="" type="checkbox"/> Condition # 1 (Additional Right of Way Required and Cleared)					
All necessary right of way, including control of access rights when applicable, have been acquired including legal and physical possession. Trial or appeal of cases may be pending in court but legal possession has been obtained. There may be some improvements remaining on the right-of-way, but all occupants have vacated the lands and improvements, and KYTC has physical possession and the rights to remove, salvage, or demolish all improvements and enter on all land. Just Compensation has been paid or deposited with the court. All relocations have been relocated to decent, safe, and sanitary housing or that KYTC has made available to displaced persons adequate replacement housing in accordance with the provisions of the current FHWA directive.					
<input type="checkbox"/> Condition # 2 (Additional Right of Way Required with Exception)					
The right of way has not been fully acquired, the right to occupy and to use all rights-of-way required for the proper execution of the project has been acquired. Some parcels may be pending in court and on other parcels full legal possession has not been obtained, but right of entry has been obtained, the occupants of all lands and improvements have vacated, and KYTC has physical possession and right to remove, salvage, or demolish all improvements. Just Compensation has been paid or deposited with the court for most parcels. Just Compensation for all pending parcels will be paid or deposited with the court prior to AWARD of construction contract					
<input type="checkbox"/> Condition # 3 (Additional Right of Way Required with Exception)					
The acquisition or right of occupancy and use of a few remaining parcels are not complete and/or some parcels still have occupants. All remaining occupants have had replacement housing made available to them in accordance with 49 CFR 24.204. KYTC is hereby requesting authorization to advertise this project for bids and to proceed with bid letting even though the necessary right of way will not be fully acquired, and/or some occupants will not be relocated, and/or the just compensation will not be paid or deposited with the court for some parcels until after bid letting. KYTC will fully meet all the requirements outlined in 23 CFR 635.309(c)(3) and 49 CFR 24.102(j) and will expedite completion of all acquisitions, relocations, and full payments after bid letting and prior to AWARD of the construction contract or force account construction.					
Total Number of Parcels on Project		46	EXCEPTION (S) Parcel #		ANTICIPATED DATE OF POSSESSION WITH EXPLANATION
Number of Parcels That Have Been Acquired					
Signed Deed		46			
Condemnation					
Signed ROE					
Notes/ Comments (Use Additional Sheet if necessary)					
LPA RW Project Manager			Right of Way Supervisor		
Printed Name			Printed Name	Michael H. Price	
Signature			Signature		
Date			Date	09/13/2018	
Asst. Right of Way Director			FHWA		
Printed Name	Kelly B. Davine		Printed Name		
Signature			Signature		
Date	11/15/18		Date		

UTILITIES AND RAIL CERTIFICATION NOTE

**HARDIN COUNTY
FEDERAL PROJECT # 00STP7868001
UNIFIED PROJECT NUMBER JP0213 047 65579
CARDINAL DRIVE/KY 361 EXTENSION
ITEM #4-7020.00**

GENERAL PROJECT NOTE ON UTILITY PROTECTION

N/A

NOTE: DO NOT DISTURB THE FOLLOWING UTILITIES LOCATED WITHIN THE PROJECT DISTURB LIMITS

There are various utility poles in the disturb limits that the highway contractor will have to work around.

The Contractor is fully responsible for protection of all utilities listed above

THE FOLLOWING COMPANIES ARE RELOCATING/ADJUSTING THEIR UTILITIES WITHIN THE PROJECT LIMITS AND WILL BE COMPLETE PRIOR TO CONSTRUCTION

N/A

THE FOLLOWING COMPANIES HAVE FACILITIES TO BE RELOCATED/ADJUSTED BY THE COMPANY OR THE COMPANY'S SUBCONTRACTOR AND IS TO BE COORDINATED WITH THE ROAD CONTRACT

KU, Brandenburg Telephone, Windstream, and Comcast are relocating overhead utilities and will be complete by July 1, 2019.

THE FOLLOWING COMPANIES HAVE FACILITIES TO BE RELOCATED/ADJUSTED BY THE ROAD CONTRACTOR AS INCLUDED IN THIS CONTRACT

The City of Elizabethtown has gas and sewer facilities that are to be relocated by the highway contractor as indicated in the plans.

THE FOLLOWING RAIL COMPANIES HAVE FACILITIES IN CONJUNCTION WITH THIS PROJECT AS NOTED

No Rail Involved Minimal Rail Involved (See Below) Rail Involved (See Below)

UTILITIES AND RAIL CERTIFICATION NOTE

**HARDIN COUNTY
FEDERAL PROJECT # 00STP7868001
UNIFIED PROJECT NUMBER JP0213 047 65579
CARDINAL DRIVE/KY 361 EXTENSION
ITEM #4-7020.00**

UNDERGROUND FACILITY DAMAGE PROTECTION – BEFORE YOU DIG

The contractor shall make every effort to protect underground facilities from damage as prescribed in the Underground Facility Damage Protection Act of 1994, Kentucky Revised Statute KRS 367.4901 to 367.4917. It is the contractor's responsibility to determine and take steps necessary to be in compliance with federal and state damage prevention directives. The contractor is instructed to contact KY 811 for the location of existing underground utilities. Contact shall be made a minimum of two (2) and no more than ten (10) business days prior to excavation.

The contractor shall submit Excavation Locate Requests to the Kentucky Contact Center (KY 811) via web ticket entry. The submission of this request does not relieve the contractor from the responsibility of contacting non-member facility owners, whom are to be contacted through their individual Protection Notification Center. It may be necessary for the contractor to contact the County Court Clerk to determine what utility companies have facilities in the area. Non-compliance with these directives can result in the enforcement of penalties.

SPECIAL CAUTION NOTE – PROTECTION OF UTILITIES

The contractor will be responsible for contacting all utility facility owners on the subject project to coordinate his activities. The contractor will coordinate his activities to minimize and, where possible, avoid conflicts with utility facilities. Due to the nature of the work proposed, it is unlikely to conflict with the existing utilities beyond minor facility adjustments. Where conflicts with utility facilities are unavoidable, the contractor will coordinate any necessary relocation work with the facility owner and Resident Engineer. The Kentucky Transportation Cabinet maintains the right to remove or alter portions of this contract if a utility conflict occurs.

UTILITIES AND RAIL CERTIFICATION NOTE

**HARDIN COUNTY
FEDERAL PROJECT # 00STP7868001
UNIFIED PROJECT NUMBER JP0213 047 65579
CARDINAL DRIVE/KY 361 EXTENSION
ITEM #4-7020.00**

The utility facilities as noted in the previous section(s) have been determined using data garnered by varied means and with varying degrees of accuracy: from the facility owners, a result of S.U.E., field inspections, and/or reviews of record drawings. The facilities defined may not be inclusive of all utilities in the project scope and are not Level A quality, unless specified as such. It is the contractor's responsibility to verify all utilities and their respective locations before excavating.

Please Note: The information presented in this Utility Note is informational in nature and the information contained herein is not guaranteed.

AREA UTILITIES CONTACT LIST

<u>Utility Company/Agency</u>	<u>Contact Name</u>	<u>Contact Information</u>
Windstream	Steve Johnson	859-357-6209
City of Etown Sewer	Michael Page	270-765-6121
City of Etown Gas	Matthew Hobbs	270-765-6121
KU/LG&E	Caroline Justice	502-627-3708
Comcast	Steve Gaddie	270-706-0326
Brandenburg Telephone	Kyle Dalton	270-928-4466
Hardin County Water District #2	Forrest Pollock	270-737-1056

GENERAL UTILITY NOTES AND INSTRUCTIONS APPLICABLE TO ALL UTILITY WORK MADE A PART OF THE ROAD CONSTRUCTION CONTRACT

The contractor should be aware the following utility notes and KYTC Utility Bid Item Descriptions shall supersede, replace and take precedence over any and all conflicting information that may be contained in utility owner supplied specifications contained in the contract, on plans supplied by the utility owner, or any utility owner specifications or information externally referenced in this contract.

Where information may have been omitted from these notes, bid item descriptions, utility owner supplied specifications or plans; the KYTC Standard Specifications for Road and Bridge Construction shall be referenced.

PROTECTION OF EXISTING UTILITIES

The existing utilities shown on the plans are shown as best known at the time the plans were developed and are to be used as a guide only by the Contractor. The Contractor shall use all means at his disposal to accurately locate all existing utilities, whether shown on the plans or not, prior to excavation. The contractor shall protect these utilities during construction. Any damage to existing utilities during construction that are shown or not shown on the plans shall be repaired at the Contractor's expense.

PREQUALIFIED UTILITY CONTRACTORS

Some utility owners may require contractors that perform relocation work on their respective facilities as a part of the road contract be prequalified or preapproved by the utility owner. Those utility owners with a prequalification or preapproval requirement are as follows:

No contractors are required to be prequalified or preapproved by the utility owner(s) to perform utility relocation work under this contract.

The bidding contractor needs to review the above list and choose from the list of approved subcontractors at the end of these general notes as identified above before bidding. When the list of approved subcontractors is provided, only subcontractors shown on the following list(s) will be allowed to work on that utility as a part of this contract.

When the list of approved subcontractors for the utility work is not provided in these general notes, the utility work can be completed by the prime contractor. If the prime contractor chooses to subcontract the work, the subcontractor shall be prequalified with the KYTC Division of Construction Procurement in the

work type of “Utilities” (I33). Those who would like to become prequalified may contact the Division of Construction Procurement at (502) 564-3500. Please note: it could take up to 30 calendar days for prequalification to be approved. The prequalification does not have to be approved prior to the bid, but must be approved before the subcontract will be approved by KYTC and the work can be performed.

CONTRACT ADMINISTRATION RELATIVE TO UTILITY WORK

All utility work is being performed as a part of a contract administered by KYTC; there is not a direct contract between the utility contractor and utility owner. The KYTC Section Engineer is ultimately responsible for the administration of the road contract and any utility work included in the contract.

SUBMITTALS AND CORRESPONDENCE

All submittals and correspondence of any kind relative to utility work included in the road contract shall be directed to the KYTC Section Engineer, a copy of which may also be supplied to the utility owner by the contractor to expedite handling of items like material approvals and shop drawings. All approvals and correspondence generated by the utility owner shall be directed to the KYTC Section Engineer. The KYTC Section Engineer will relay any approvals or correspondence to the utility contractor as appropriate. At no time shall any direct communication between the utility owner and utility contractor without the communication flowing through the KYTC Section Engineer be considered official and binding under the contract.

ENGINEER

Where the word “Engineer” appears in any utility owner specifications included in this proposal, utility owner specifications included as a part of this contract by reference or on the utility relocation plans, it shall be understood the “Engineer” is the Kentucky Transportation Cabinet (KYTC) Section Engineer or designated representative and the utility owner engineer or designated representative jointly. Both engineers must mutually agree upon all decisions made with regard to the utility construction. The Transportation Cabinet, Section Engineer shall make all final decisions in all disputes.

INSPECTOR OR RESIDENT PROJECT REPRESENTATIVE

Where the word “Inspector” or “Resident Project Representative” appears in the utility specifications included in this proposal, utility owner specifications included as a part of this contract by reference or on the utility relocation plans, it shall be understood the “Inspector” or “Resident Project Representative” is the utility owner inspector and KYTC inspector jointly. The Transportation Cabinet, Section Engineer shall make all final decisions in all disputes.

NOTICE TO UTILITY OWNERS OF THE START OF WORK

One month before construction is to start on a utility, the utility contractor shall make notice to the KYTC Section Engineer and the utility owner of when work on a utility is anticipated to start. The utility contractor shall again make confirmation notice to the KYTC Section Engineer and the utility owner one week before utility work is to actually start.

UTILITY SHUTDOWNS

The Contractor shall not shut down any active and in-service mains, utility lines or services for any reason unless specifically given permission to do so by the utility owner. The opening and closing of valves and operating of other active utility facilities for main, utility line or utility service shut downs are to be performed by the utility owner unless specific permission is given to the contractor by the owner to make shutdowns. If and when the utility owner gives the contractor permission to shutdown mains, utility lines or utility services, the contractor shall do so following the rules, procedures and regulations of the utility owner. Any permission given by the utility owner to the contractor to shutdown active and in-service mains, utility lines or services shall be communicated to the KYTC Section Engineer by the utility owner that such permission has been given.

Notice to customers of utility shut downs is sometimes required to be performed by the utility contractor. The contractor may be required; but, is not limited to, making notice to utility customers in a certain minimum amount of time in advance of the shut down and by whatever means of communication specified by the utility owner. The means of communication to the customer may be; but is not limited to, a door hanger, notice by newspaper ad, telephone contact, or any combination of communication methods deemed necessary, customary and appropriate by the utility owner. The contractor should refer to the utility owner specifications for requirements on customer notice.

Any procedure the utility owner may require the contractor to perform by specification or plan note and any expense the contractor may incur to comply with the utility owner's shut down procedure and notice to customers shall be considered an incidental expense to the utility construction.

CUSTOMER SERVICE AND LATERAL ABANDONMENTS When temporary or permanent abandonment of customer water, gas, or sewer services or laterals are necessary during relocation of utilities included in the contract, the utility contractor shall perform these abandonments as part of the contract as incidental work. No separate payment will be made for service line and lateral abandonments. The contractor shall provide all labor, equipment and materials to accomplish the temporary or permanent abandonment in accordance with the plans, specifications and/or as directed by the engineer. Abandonment may include, but is not limited to, digging down on a water or gas main at the tap to turn off the tap valve or corporation stop and/or capping or plugging the tap, digging down on a sewer tap at the main and plugging or capping the tap, digging down on a service line or lateral at a location shown on the plans or agreeable to the engineer and capping or plugging, or performing any other work necessary to abandon the service or lateral to satisfactorily accomplish the final utility relocation.

STATIONS AND DISTANCES

All stations and distances, when indicated for utility placement in utility relocation plans or specifications, are approximate; therefore, some minor adjustment may have to be made during construction to fit actual field conditions. Any changes in excess of 6 inches of plan location shall be reviewed and approved jointly by the KYTC Section Engineer or designated representative and utility owner engineer or designated representative. Changes in location without prior approval shall be remedied by the contractor at his own expense if the unauthorized change creates an unacceptable conflict or condition.

RESTORATION

Temporary and permanent restoration of paved or stone areas due to utility construction shall be considered incidental to the utility work. No separate payment will be made for this work. Temporary restoration shall be as directed by the KYTC Section Engineer. Permanent restoration shall be "in-kind" as existing.

Restoration of seed and sod areas will be measured and paid under the appropriate seeding and sodding bid items established in the contract for roadway work.

BELOW ARE NOTES FOR WHEN "INST" ITEMS ARE IN THE CONTRACT MEANING THE UTILITY COMPANY IS PROVIDING CERTAIN MATERIALS FOR UTILITY RELOCATION

MATERIAL

Contrary to Utility Bid Item Descriptions, those bid items that have the text "**Inst**" at the end of the bid item will have the major components of the bid item provided by the utility owner. No direct payment will be made for the major material component(s) supplied by the utility company. All remaining materials required to construct the bid item as detailed in utility bid item descriptions, in utility specifications and utility plans that are made a part of this contract will be supplied by the contractor. The contractor's bid price should reflect the difference in cost due to the provided materials.

The following utility owners have elected to provide the following materials for work under this contract:

No materials are being supplied by the utility owner(s). All materials are to be supplied by the contractor per bid item descriptions, utility specifications and utility plans.

SECURITY OF SUPPLIED MATERIALS

If any utility materials are to be supplied by the utility owner, it will be the responsibility of the utility contractor to secure all utility owner supplied materials after delivery to the project site. The utility contractor shall coordinate directly with the utility owner and their suppliers for delivery and security of the supplied materials. Any materials supplied by the utility owner and delivered to the construction site that are subsequently stolen, damaged or vandalized and deemed unusable shall be replaced with like materials at the contractor's expense.

Standard Gas Bid Item Descriptions

BOLLARDS This item is for payment for furnishing and installing protective guard posts at above ground utility installations. A bollard may consist of, but not limited to, a steel post set in concrete or any other substantial post material. This item shall include all labor, equipment, and materials needed for complete installation of the bollard as specified by the utility owner specifications and plans. If the Company does not have specifications, KYTC's Specifications shall be referenced. This item shall be paid EACH (EA) when complete.

NOTE: A bid code for this item has been established in standard roadway bid items and shall be used for payment of this item. The bid code is 21341ND.

G DIRECTIONAL BORE Payment under this item is made whenever the plans or specifications specifically show directional boring is to be utilized in order to minimize the impact of open cut for the installation of gas main under streets, creeks, etc. Payment under this item shall include the specified bore pipe, labor, and equipment. No separate payment shall be made for bore pipe installed in the bore whether used as a carrier pipe or an encasement of a separate carrier pipe. Carrier pipe installed within a bore pipe shall be paid separately under pipe items. Payment under this item shall be for all sizes and not be size specific. No separate bid items will be established for size variations. The bore pipe sizes to be included under this item shall be as shown on the plans and/or in the specifications. This bid item shall also include the cost of pre and/or post directional bore gas installation video inspection of adjacent sanitary and storm sewer mains, manholes, and laterals when the utility specifications associated with the contract require such video inspection. Please refer to the Utility Company's Specifications. If the Company does not have specifications, KYTC's Specifications shall be referenced. This item shall be paid LINEAR FEET (LF) when complete.

G ELECTRONIC ID MARKER This bid item is to pay for labor, equipment, computer programming, and installation of an electronic ID marker at the locations shown on the plans or as directed by the engineer. The marker may be in the form of a ball, disk, cylinder, post, or other shape as required by specification and may be buried, at grade, or above grade as specified. Please refer to the Utility Company's Specifications. If the Company does not have specifications, KYTC's Specifications shall be referenced. Paid EACH (EA) when complete.

NOTE: This bid item is not for payment of standard non-electronic markers or monuments. A separate "Line Marker" bid item is established for this purpose.

G ENCASUREMENT STEEL BORED This item shall include the steel encasement pipe size as specified on the plans and in the specifications, casing spacers, end seals, vents, labor, and equipment to bore and install the encasement in accordance with the plans and specifications, complete and ready for use. The size shall be the measured internal diameter of the encasement pipe. The sizes of encasement to be paid under the size ranges specified in the bid items shall be as follows:

- Range 1 = All encasement sizes greater than 2 inches to and including 6 inches
- Range 2 = All encasement sizes greater than 6 inches to and including 10 inches
- Range 3 = All encasement sizes greater than 10 inches to and including 14 inches
- Range 4 = All encasement sizes greater than 14 inches to and including 18 inches
- Range 5 = All encasement sizes greater than 18 inches to and including 24 inches
- Range 6 = All encasement sizes greater than 24 inches

(Encasement sizes of 2 inches internal diameter or less shall not be paid separately; but, shall be considered incidental to the carrier pipe.) Payment under this bid item shall not include the carrier pipe. Carrier pipe shall be paid under a separate bid item. Please refer to the Utility Company's Specifications. If the Company does not have specifications, KYTC's Specifications shall be referenced. This item shall be paid LINEAR FEET (LF) when complete.

G ENCASEMENT STEEL OPEN CUT This item shall include the steel encasement pipe size as specified on the plans and in the specifications, casing spacers, end seals, vents, labor, and equipment to open cut and install the encasement in accordance with the plans and specifications, complete and ready for use. The size shall be the measured internal diameter of the encasement pipe. The size encasement to be paid under the size ranges specified in the bid items shall be as follows:

- Range 1 = All encasement sizes greater than 2 inches to and including 6 inches
- Range 2 = All encasement sizes greater than 6 inches to and including 10 inches
- Range 3 = All encasement sizes greater than 10 inches to and including 14 inches
- Range 4 = All encasement sizes greater than 14 inches to and including 18 inches
- Range 5 = All encasement sizes greater than 18 inches to and including 24 inches
- Range 6 = All encasement sizes greater than 24 inches

(Encasement sizes of 2 inches internal diameter or less shall not be paid separately; but, shall be considered incidental to the carrier pipe.) Payment under this bid item shall not include the carrier pipe. Carrier pipe shall be paid under a separate bid item. Please refer to the Utility Company's Specifications. If the Company does not have specifications, KYTC's Specifications shall be referenced. This item shall be paid LINEAR FEET (LF) when complete.

G FARM TAP AND REGULATOR This item is for the installation of gas service tap and regulator assembly on a gas transmission main. This item shall include excavation, labor, equipment, and all tapping, piping, fittings, and regulator materials to install the farm tap and regulator assembly in accordance with the plans, specifications, and standard drawings complete and ready for use. Only one pay item has been established for Farm Tap and Regulator installations. Payment shall be made under this item regardless of farm tap service and regulator size. No separate pay items will be established for size variation. Please refer to the Utility Company's Specifications. If the Company does not have specifications, KYTC's Specifications shall be referenced. This item shall be paid EACH (EA) when complete.

G LINE MARKER This item is for payment for furnishing and installing a gas utility line marker as specified by the utility owner specifications and plans. A line marker may consist of a post or monument of whatever materials specified and shall include markings and/or signage on same as specified by plans or specifications. This item shall include all labor, equipment, and materials needed for complete installation of the marker. This item shall be paid EACH (EA) when complete.

NOTE: This bid item is not for payment of "Electronic ID Markers". Electronic ID Markers are paid under a separate bid item.

G MAIN ABANDON This bid item is in full payment for all efforts in abandonment of all gas mains and facilities shown to be abandoned on the plans, for removal of any sections of abandoned main that is in conflict with road construction, and for nitrogen purge and plug of any sections of main that are to remain. All work shall be done in accordance with the plans and specifications, and in accordance with

all pipeline safety regulations. This bid item is for all work to abandon and purge gas main in the total project regardless of size or length. No adjustment in the unit bid price will be allowed if the scope of work described in this item should increase in this contract for any reason. Please refer to the Utility Company's Specifications. If the Company does not have specifications, KYTC's Specifications shall be referenced. This item is to be paid LUMP SUM (LS) when complete.

G MAIN POINT RELOCATE This item is intended for payment for horizontal and/or vertical relocation of a short length of an existing main at the locations shown on the plans. This bid item is to be used to relocate an existing gas main at point locations such as to clear a conflict at a proposed drainage structure, pipe or any other similar short relocation situation. All new materials are to be used. The materials provided shall be of the same type and specification as those that exist. Substitution of alternative materials shall be approved by the engineer in advance on a case by case basis. Payment under this item shall be for each location requiring an existing main to be relocated horizontally or vertically regardless of pipe size or relocation length. No separate pay items will be established for pipe size variations or relocation segment length variations. Main Point Relocate shall not be paid on a linear feet basis; but shall be paid EACH (EA) at each location when complete and placed in service. Please refer to the Utility Company's Specifications. If the Company does not have specifications, KYTC's Specifications shall be referenced.

G METER AND REGULATOR This bid item description shall be used for all meter and regulator bid items of every size except those defined as "Special". These pay items are for all labor, equipment, and materials needed for the installation of a service meter and regulator assembly at the locations shown on the plans or as directed by the engineer in accordance with specifications and standard drawings complete and ready for use. Materials to be provided under this bid item shall include, but are not limited to, meter, regulator, piping, fittings, building anchoring brackets, and hardware needed to create and install the assembly. Please refer to the Utility Company's Specifications. If the Company does not have specifications, KYTC's Specifications shall be referenced. This item shall be paid EACH (EA) when complete.

G PIPE This description shall apply to all polyethylene/plastic and steel pipe bid items of every size and type to be used as gas main, except those bid items defined as "Special". This item includes the pipe specified by the plans and specifications, all fittings (including, but not limited to, bends, tees, reducers, plugs, and caps), tracing wire with test boxes (if required by specification), corrosion protective coatings of steel pipe and fittings, labor, equipment, excavation, bedding, restoration, pressure testing, backfill, etc., required to install the specified new pipe and new fittings at the locations shown on the plans, or as directed, in accordance with the specifications and standard drawings complete and ready for use. For steel pipe, this bid item shall include all cathodic protection anodes, lead wire, test boxes or stations, and any accessories. No additional payment will be made for rock excavation. This bid item shall include material and placement of flowable fill under existing and proposed pavement, and wherever else specified on the plans or in the specifications. This bid item shall also include the cost of pre and/or post directional bore gas installation video inspection of adjacent sanitary and storm sewer mains, manholes, and laterals when the utility specifications associated with the contract require such video inspection. Measurement of quantities under this item shall be through valves (including horizontal measurements through above grade valves), fittings, encasements, and directional bores (only when a separate carrier pipe is specified within the directional bore pipe). Measurements shall be further defined to be to the center of tie-in where new pipe contacts existing pipe at the center of connecting fittings, to the outside face of vault or structure walls, or to the point of main termination at dead ends. No separate payment will be made under pipe items when the directional bore pipe is the carrier pipe. Please refer to the Utility

Company's Specifications. If the Company does not have specifications, KYTC's Specifications shall be referenced. This item shall be paid LINEAR FEET (LF) when complete.

G REGULATOR STATION Includes all labor, equipment, materials and restoration, to install a new gas regulator station as indicated on plans and on standard drawings complete and ready for use. Only one pay item has been established for regulator station installations. Payment shall be made under this item regardless of regulator station size. No separate pay items will be established for size variation. Please refer to the Utility Company's Specifications. If the Company does not have specifications, KYTC's Specifications shall be referenced. This item shall be paid EACH (EA) when complete.

NOTE: This item is to be used to pay for regulator stations to reduce the pressure of gas from a higher pressure main to feed a lower pressure main. This item is not to be used to pay for regulators used on individual customer service lines.

G SERVICE LONG SIDE This bid item description shall apply to all service line installations of every size bid up to and including 2 inch inside diameter, except those service bid items defined as "Special". This item includes the specified piping material, main tap, coupling for connecting the new piping to the surviving existing piping, encasement of 2 inches or less internal diameter (if required by plan or specification), labor, equipment, excavation, backfill, testing, and restoration, at the locations shown on the plans or as directed, in accordance with the specifications and standard drawings, complete and ready for use. This bid item is to pay for service installations where the ends of the service connection are on opposite sides of the public roadway and the service line crosses the centerline of the public roadway as shown on the plans. The length of the service line is not to be specified. Payment under this item shall not be restricted by a minimum or maximum length. The contractor shall draw his own conclusions as to the length of piping that may be needed. Payment under this item shall include boring, jacking, or excavating across the public roadway for placement. Placement of a service across a private residential or commercial entrance alone shall not be reason to make payment under this item. Private or commercial entrances shall not be considered a public roadway in defining payment under this item. This pay item does not include installation or relocation of meters. Meters will be paid separately. This bid item shall also include the cost of pre and/or post directional bore gas installation video inspection of adjacent sanitary and storm sewer mains, manholes, and laterals when the utility specifications associated with the contract require such video inspection. No additional payment will be made for rock excavation or for special bedding required in rock excavation. Please refer to the Utility Company's Specifications. If the Company does not have specifications, KYTC's Specifications shall be referenced. This item shall be paid EACH (EA) when complete.

G SERVICE SHORT SIDE This bid item description shall apply to all service line installations of every size up to and including 2 inch internal diameter, except those service bid items defined as "Special". This item includes installation of the specified piping material of the size specified on plans, encasement of 2 inches or less internal diameter (if required by plan or specification), main tap, coupling for connecting the new piping to the surviving existing piping, labor, equipment, excavation, backfill, testing, and restoration, at the locations shown on the plans or as directed, in accordance with the specifications and standard drawings, complete and ready for use. This bid item is to pay for service installations where both ends of the service connection are on the same side of the public roadway, or when an existing service crossing a public roadway will remain and is being extended, reconnected, or relocated with all work on one side of the public roadway centerline as shown on the plans. The length of the service line is not to be specified and shall not be restricted to any minimum or maximum length. Payment shall be made under this item even if the service crosses a private residential or commercial entrance; but, not a public roadway. Private or commercial entrances shall not be considered a public

roadway in defining payment under this item. The contractor shall draw his own conclusions as to the length of piping that may be needed. This pay item does not include installation or relocation of meters. Meters will be paid separately. This bid item shall also include the cost of pre and/or post directional bore gas installation video inspection of adjacent sanitary and storm sewer mains, manholes, and laterals when the utility specifications associated with the contract require such video inspection. No additional payment will be made for rock excavation or for bedding required in rock excavation. Please refer to the Utility Company's Specifications. If the Company does not have specifications, KYTC's Specifications shall be referenced. This item shall be paid EACH (EA) when complete.

G SERVICE RELOCATE This item is for the relocation of an existing gas service line where a meter is not involved, and where an existing service line can easily be adjusted by excavating alongside and moving the line horizontally and/or vertically a short distance without cutting the service line to avoid conflicts with road construction. This item shall include excavation, labor, equipment, bedding, and backfill to relocate the line in accordance with the plans and specifications complete and ready for use. Payment under this item shall be for each location requiring relocation. Payment shall be made under this item regardless of service size or relocation length. No separate pay items will be established for size or length variation. Please refer to the Utility Company's Specifications. If the Company does not have specifications, KYTC's Specifications shall be referenced. This item shall be paid EACH (EA) when complete.

G TIE-IN This bid description shall be used for all polyethylene/plastic or steel gas main tie-in bid items of every size except those that include a temporary bypass or are defined as "Special". This item includes all labor, equipment, excavation, fittings, sleeves, reducers, couplings, restoration, testing and backfill required to make the gas main tie-in as shown on the plans, and in accordance with the specifications complete and ready for use. Pipe for tie-ins shall be paid under separate bid items. No additional payment will be made for rock excavation. This bid item shall also include material and placement of flowable fill backfill under existing and proposed pavement, and wherever else specified on the plans or in the specifications. Please refer to the Utility Company's Specifications. If the Company does not have specifications, KYTC's Specifications shall be referenced. This item shall be paid EACH (EA) when complete.

G TIE-IN W/BYPASS This bid description shall be used for all polyethylene/plastic or steel gas main tie-in bid items that include temporary bypass of every size except those defined as "Special". This item includes all labor, equipment (including tapping, stopple and/or squeeze equipment), excavation, permanent and temporary fittings (including, but not limited to, tees, split tees, bends, reducers, plugs, caps, and couplings), temporary bypass piping, restoration, testing and backfill required to make the gas main tie-in with temporary bypass as shown on the plans, and in accordance with the specifications complete and ready for use. Mainline pipe for tie-ins shall be paid under separate bid items. No additional payment will be made for rock excavation. This bid item shall also include material and placement of flowable fill backfill under existing and proposed pavement, and wherever else specified on the plans or in the specifications. Please refer to the Utility Company's Specifications. If the Company does not have specifications, KYTC's Specifications shall be referenced. This item shall be paid EACH (EA) when complete.

NOTE: The tie-in size reflected in the bid item reflects the nominal internal diameter size of the main gas line being tied-in, not the bypass pipe size.

G VALVE This description shall apply to all buried valves of every size and type required in the plans and specifications except those bid items defined as "Special". Payment under this description is to be

for gas valves being installed with new main. This item includes the valve as specified in the plans and specifications, protective coating and corrosion protection, labor, equipment, excavation, valve box and valve stem extensions, backfill, restoration, testing, and etc., required to install the specified valve at the location shown on the plans in accordance with the specifications and standard drawings complete and ready for use. Please refer to the Utility Company's Specifications. If the Company does not have specifications, KYTC's Specifications shall be referenced. This item shall be paid EACH (EA) when complete.

G VALVE ABOVE GRADE This description shall apply to all above grade valve assemblies of every size and type required in the plans and specifications except those bid items defined as "Special". Payment under this description is to be for above grade gas valves being installed with new main. This item includes the above grade valve, pipe, and fittings as specified in the plans, specifications and standard drawings. This bid items shall also include protective coating and corrosion protection, labor, equipment, excavation, backfill, restoration, testing, etc., required to install the specified above grade valve at the location shown on the plans in accordance with the specifications and standard drawings complete and ready for use. Please refer to the Utility Company's Specifications. If the Company does not have specifications, KYTC's Specifications shall be referenced. This item shall be paid EACH (EA) when complete.

G VALVE BOX ADJUST Includes all labor, equipment, valve box and valve stem extensions (if required), excavation, backfill, concrete pad around valve box (when specified in specifications or plans), restoration, etc. to adjust the top of the box to finished grade complete and ready for use. Please refer to the Utility Company's Specifications. If the Company does not have specifications, KYTC's Specifications shall be referenced. This item shall be paid EACH (EA) when complete.

G WELD X-RAY INSPECTION This description shall apply to all radiographic x-ray inspections of steel pipe joints of every size within the pipe size ranges given in the bid item text. This bid includes all labor, equipment, materials, to assess the acceptability of the weld to comply with specifications and to industry and regulatory standards. Please refer to the Utility Company's Specifications. If the Company does not have specifications, KYTC's Specifications shall be referenced. This item shall be paid EACH (EA) for each pipe joint inspected.

COMPENSATION SCHEDULE AND DESCRIPTION OF WORK

It is the intent of this contract that the "Compensation Schedule and Description of Work" cover the entire work as set forth in the Description of Work.

All pipe and material will be received at Jobsite.

This construction covers the installation of complete distribution main and/or services; and specifically does include all ditch, street, creek and roadway crossings. Also included are hauling and stringing of pipeline materials; ditching, boring and other special excavating; lining, tacking and welding; bending pipe; installing valves and fittings; applying protective coating; laying, cleaning and testing pipe; backfilling; purging; installing welding bonds; insulating and installing special items for cathodic protection; installing valve boxes; installing anchors; removing and, if necessary, replacing gravel, top soil, sod, concrete, asphalt and other surfacing materials; and all other work necessary to effect a complete and serviceable natural gas installation. Also, included is the restoration of right-of-way which entails grading, seeding, and mulching.

The items of work to be completed under our Specifications are as follows:

SPECIFICATIONS AND SPECIAL INSTRUCTIONS TO CONTRACTOR

- A. Contractor will furnish all labor, material, auto and miscellaneous expense in connection with the removal and/or replacement of sidewalks, fences, curbs, gutters, driveways, streets, gravel roads and highways to the satisfaction of property owners and local authorities. Contractor will be reimbursed only for cutting and replacement of pavement as set forth in "Compensation Schedule and Description of Work".
- B. It is further understood and agreed that all creeks, bayous, ditches, public or private highways, roadways or pedestrian-way crossings, sidewalks, city streets and alleys crossed by the gas lines will be included in prices bid on other items and no additional compensation will be allowed unless specifically set up under "Compensation Schedule and Description of Work".
- C. All mains installed under this contract shall have a minimum cover of 40" unless specified otherwise on the plans or as directed by the Field Engineer.
- D. When, in the process of trenching or excavating, the Contractor encounters soil containing rock that precludes hand or machine digging or boring, such additional work involved shall constitute an extra.
- E. **It is the intent of this contract that the unit price will cover all costs in connection with this job.**
- F. **When a project contains extras or any work which is not covered in the "Compensation Schedule and Description of Work", the Contractor must obtain written authorization from the Owner and the price for such extra work must be agreed upon prior to the performance of said extra work, and daily time sheets and invoices shall be furnished.**
- G. If, under this agreement, any extra work is done for which a price has not been established and the Contractor completes said project without having first reached an agreement as to the price to be paid by the Owner for such extra work, the Owner reserves the right to fix the price to be paid to the Contractor or to refuse payment entirely for such extra work.
- H. Welding procedures and welders performing work under this contract must be qualified under API Standard 1104, "Standard for Field Welding of Pipe Lines".
- I. Owner has the right to x-ray any weld of his choosing and at his discretion. All welds selected for testing will be X-rayed by a qualified NDT contractor. Contractor is advised that X-ray crews will be scheduled at the discretion of Owner's Engineer or Inspector. Final tie-ins will be X-rayed.
- J. All coated steel pipe two (2) inches and larger, including field joints, prior to being backfilled will be checked for holidays by

SPECIAL INSTRUCTIONS TO CONTRACTOR

- means of a holiday detector. Detector to be furnished by Contractor and approved by Engineer. Contractor will repair all holidays recorded by the detector with an approved coating material and pipe will again be checked with detector until all holidays are eliminated.
- K. All steel pipe installed by directional drilling will have the joints coated with Tape Coat. All other pipe joints and irregular shaped equipment (valves, TDW fittings, etc.) will be coated with Trenton Wax-Tape Primer and Trenton Wax-Tape.
- L. Per foot units under the "Compensation Schedule and Description of Work" mean horizontal linear footage. This work shall be bid and paid on the same basis.
- M. Contractor is responsible for supplying nitrogen for final testing of the installation. Contractor will provide necessary labor and equipment to conduct the final testing. Final shall be witnessed by Owner and results approved by the project engineer.
- N. All facilities shall be tested as follows.

For 6" High Pressure piping and appurtenances:

Test medium shall be nitrogen.
Test pressure shall be 450 psig.
Test duration shall be 12 hours.

For 2" steel main piping and appurtenances:

Test medium shall be nitrogen.
Test pressure shall be 100 psig.
Test duration shall be 12 hours.

For 1" steel service piping and appurtenances:

Test medium shall be nitrogen.
Test pressure shall be 100 psig.
Test duration shall be 15 minutes.

For Mueller fitting assemblies:

Test medium shall be air or nitrogen.
Test pressure shall be 300 psig.
Test duration shall be 1 hour.

Tie-in joints and / or service tees not pressure tested must be soap tested and inspected for leaks at operating pressure.

- O. A pre-installation leak test shall be performed on all pipe that is installed via directional drilling. Test pressure shall be a minimum of 100 psig for a duration of fifteen minutes. Test medium may be air or nitrogen. Soap test all joints during this test.

SPECIAL INSTRUCTIONS TO CONTRACTOR

- P. Contractor is responsible for clearing the right-of-way, removing and properly disposing of all stumps and debris, and final grading of the right-of-way. Contractor is responsible for final restoration of the right-of-way, which shall include disking, planting grass seed, and mulching. If settling occurs over the pipeline after Contractor has completed work on the project, Contractor shall provide the materials and labor to restore the right-of-way to a satisfactory condition.
- Q. **Contractor is responsible for cleaning up trash and debris from the jobsite on a daily basis.**
- R. **Contractor shall replace any fences cut with new fencing material and install gates in every fence crossed.**
- S. Contractor shall install stopple fittings as shown on the project drawings. Contractor will provide the necessary labor and equipment to operate line tapping and plugging equipment for all taps. Contractor will furnish the tapping and plugging equipment for all taps.
- T. Contractor shall install supports under the Mueller fittings and valves as needed.
- U. Contractor shall secure any bell holes left open overnight by installing barricades, net fencing, or other protection suitable to Owner's Engineer or Inspector. Contractor shall also place flashing lights adjacent to the site.
- V. Prior to testing, Contractor shall run scraper and poly pigs in the steel pipe main as many times as necessary to clean the pipeline to the satisfaction of Owner's Engineer. **Pigs will be provided by Contractor** and shall be approved by Owner's Engineer prior to use.
- W. Contractor is responsible for measuring and tallying all pipe shipments.
- X. Contractor is responsible for making and maintaining all requests to Kentucky One Call related to this project.
- Y. Contractor is responsible for having all of the equipment necessary to install the proposed facilities. No equipment will be provided by the Owner.
- Z. No work shall be performed on the project on Saturdays or Sundays unless previously approved by Owner's Engineer.
- AA. Contractor shall comply with all provisions of the Kentucky Department of Transportation Highway Permits.
- BB. Contractor shall take special care to minimize damage to telephone, water, sewer, or gas service lines. However, if damage occurs, Contractor shall immediately repair any water or sewer line and shall have on-site all materials necessary to make these repairs.

SPECIAL INSTRUCTIONS TO CONTRACTOR

- Contractor shall immediately notify the telephone company of any damage to phone or fiber optic lines.
- CC. Contractor shall restore to their original condition or better any driveways, streets, or other structures, damaged from the construction of the proposed facilities.
- DD. Upon completion of project dress-up, Contractor shall install pipeline markers at all road crossings, creek crossings, and along the right-of-way at locations designated by Engineer.
- KK. Contractor is allowed to clear route along highway right-of-way for the installation of the 8" pipeline. Under no circumstances will debris be placed on private property.
- LL. Contractor will provide Owner with as-built profiles of all directional bores.

SPECIAL INSTRUCTIONS TO CONTRACTOR

CONSTRUCTION SPECIFICATIONS

C-1 FURNISHED BY COMPANY

A. The Company will furnish, without cost to Contractor, the following materials, equipment, and services:

1. All pipe, mill wrapped, unless otherwise stated, or PE.
2. All valves, gaskets, fittings, small pipe, protective coating material, and pipe line accessories.
3. Permits for permanent crossing under railroads, highways, and along highways and railroads.
4. Lines and grades.
5. Right-of-way. The rights obtained by Company will include the right to install, maintain and remove piping and appurtenances, the right of ingress and egress, and the right to clear and keep clear. Company will furnish permits for permanent crossing under railroads, highways, and along highways. Company reserves the right to relocate sections of line on a right-of-way different from that shown on the Drawings.

NOTE: Failure by the Company to furnish drawings, materials, equipment, or service as to reasonably meet the demands of the progress schedule of the work can postpone the date specified for completing the affected portion of the work. Time of completion may be extended for the actual period of such delay. Such period of extensions shall be fixed and determined by Company. Failure of the Company to furnish drawings, materials, and equipment, or services to be furnished by Company hereunder, or the furnishing thereof ahead of schedule, shall not be the basis of any claim by Contractor against Company by reason of any delay occasioned Contractor thereby.

C-2 CONTRACTOR'S FUNCTION

A. The Contractor shall act as an erecting organization and shall furnish all supervision, labor, material, tools,

SPECIAL INSTRUCTIONS TO CONTRACTOR

office, apparatus, equipment and conveyances necessary for pipe line construction, and for receiving, unloading, checking, stringing, assembling, welding, cleaning, coating, and testing the pipeline.

B. The Contractor shall receive, prepare receipt, unload, check and store all material and equipment which arrives after the contract is awarded to him, from points of unloading, such as docks, trucks and trucking terminals, railroad depots, barges or Company's warehouse or storage yard. The Contractor shall examine material and equipment for concealed damage, report any damage to the Engineer for examination by representatives of the manufacturer or common carrier, furnish the Engineer with lists or tally sheets of material and equipment received, erect the material and auxiliary parts or loose pieces in a systematic manner where they can be readily identified and located when needed at a later date.

After the Contractor has received materials and equipment at delivery points as being in proper condition, he shall be responsible for their safety and protection from loss or damage of any nature. In case there is loss of or damage to material after being accepted by the Contractor, the Contractor will be obligated to replace this material with material exactly like the material lost or damaged including manufacturer and brand name. Pipe will be delivered to the Contractor having coating already applied. The Contractor shall repair, at his own expense, all damage to the coating resulting from his storing, handling, and subsequent operations.

C. The Contractor shall pay all demurrage charges and claims for damages to barges and cars and/or adjoining property arising out of his unloading or handling operation.

D. The Contractor shall haul and distribute materials to the points where they are to be incorporated into the gas line. Materials delivered along the line and not required at points of delivery shall be re-hauled to points where needed.

E. The price bid under each item shall include all labor, equipment, materials expenses and cost which are not properly classified under any other item or items, and which may be necessary to completely perform the work to be done under said item in the manner herein set forth and specified. The Contractor shall, without additional compensation therefore,

SPECIAL INSTRUCTIONS TO CONTRACTOR

coordinate and join together all of the various subdivisions of work and produce complete finished gas line ready for continuous operation as outlined under Description of Work.

F. Contractor declares himself fully familiar with the proposed site of work and warrants all work done by him to be completed with the best modern practice for construction of gas lines and in accordance with the Minimum Federal Safety Standards for the Distribution of Natural and Other Gas by Pipelines, notwithstanding any omissions from these specifications and drawings.

G. Company reserves the right to inspect the work, but in no manner obligates itself to supervise the construction. Contractor shall assure himself that the work is being done properly at all times and shall alone be responsible for the efficiency, safety and adequacy of his tools, equipment, employees, organization, appliances and methods.

H. The work shall be carried out in strict accordance with these specifications together with the other requirements of the contract and with the drawings.

C-3 GENERAL

A. The Contractor may establish headquarters and other necessary installations, such as tool room facilities, on the Company's property or right-of-way only at locations designated or approved by Company.

B. The means employed for doing the various classes of work shall be at the option of the Contractor subject to such suggestions or approval by the Engineer as may be necessary to safeguard the character and results of all features of the work.

C. All of the completed work on the construction work in progress, as well as machinery and equipment that may be required for the adequate execution of the work hereunder, shall be protected by the Contractor and such protection shall remain and be maintained until accepted by the Company, or until protection is no longer necessary and its removal is directed by Engineer.

D. In locations where terraces or drainage ditches are traversed by the line, any damage caused by the Contractor

SPECIAL INSTRUCTIONS TO CONTRACTOR

to the terraces and ditches shall be repaired immediately by the Contractor at his own expense. Any other damage, either on or off the right-of-way, including damages to shrubbery, evergreens, valuable trees, etc., shall be Contractor's responsibility. Contractor shall save and protect Company against any and all such damages.

E. Company assumes no responsibility for the conditions or maintenance of any road or structure that may be used by Contractor in performing the work under these specifications, or in transferring materials to and from the site of the work. No payment will be made to Contractor by Company for any work done in constructing, improving, repairing, or maintenance of any road or structure for use in the performance of work under these specifications. Roads subject to obstruction by the work shall be kept open insofar as possible.

F. Company will secure rights of ingress and egress over lands crossed by the right-of-way, but rights of ingress and egress over adjacent lands, where required, shall be secured by Contractor and any damages resulting from the use thereof shall be the Contractor's responsibility.

G. Contractor shall make all necessary provisions and do all work required by his operations under the Contract to prevent any interference with power or communication lines, with their operation or with maintenance or services thereon, all in a manner satisfactory to the Company or operators thereof and to the Engineer, and all cost incidental thereto shall be paid for by the Contractor. Any damage done by the Contractor to communication or power lines shall be the Contractor's responsibility.

H. The Contractor will be required to protect all pipe lines crossed and all adjacent pipe lines, and shall repair or replace any damage done to them. The Contractor shall also be responsible for damage to oil, gas and water lines, sewers, etc. Conflicting substructures will not be cut for the installation of new pipe. The Company will furnish the location of its own substructures and will assist the Contractor in obtaining the location of other substructures insofar as practicable; however, it is fully understood that the Company will in no way be held responsible for the locating of substructures and the Contractor will be fully liable for all loss and damage caused by the Contractor to any and all substructures.

SPECIAL INSTRUCTIONS TO CONTRACTOR

I. All gas lines, when paralleling other substructures, shall be laid a minimum of twelve (18) inches from such substructures and when crossing such substructures, the minimum clearance shall be twelve (18) inches for distribution lines and twelve (18) inches for transmission lines unless otherwise approved by the Engineer.

J. All lines within road, street and highway right-of-way shall be installed in accordance with requirements of county, city or state authorities.

K. Contractor shall furnish, place and maintain proper barricades with warning lights and signs, properly lighted with yellow lights or flares at night at all city streets and alleys, all public or private highways, roadway or pedestrian-way crossings intercepted by the gas line trenches. He shall cause barricades and lights to be placed as soon as the excavation has been made, and shall maintain them until after the pipe has been laid and the trench backfilled and made thoroughly safe for public use. The Contractor shall, in addition, comply in all particulars with any and all requirements of municipal, county, state and federal officials having jurisdiction and with any and all requirements of railroads, pipe lines, relative to methods and requirements to be used in protecting property and the public from injury or damage during his operations.

L. Contractor, after completion of work, shall completely remove and satisfactorily dispose of all temporary works to the extent directed. Contractor agrees at his sole expense to restore all field roads, drain ditches, field bridges, sidewalks, streets, alleys, and culverts or other works damaged by his operation to their original condition and to the satisfaction of the property Company or political subdivision. Contractor shall remove or grade, to the extent directed, all embankments made for construction purposes; shall satisfactorily fill excavations as directed; shall remove all plant and equipment; shall satisfactorily dispose of all rubbish from operations under this contract and shall do all work necessary to restore the right-of-way, streets, and alleys as they were at the beginning of the work under this contract, in order to maintain the "good will" of property owner along the route of the gas line.

C-4 CLEARING OF RIGHT-OF-WAY

SPECIAL INSTRUCTIONS TO CONTRACTOR

A. Gates of a permanent type shall be installed in the fences crossed by the route of the pipeline and shall be maintained to the satisfaction of the landowner and Engineer and so that livestock will be prevented from entering or leaving the property. Before cutting such fences to make these gates, fences shall be braced to prevent damage to them. Gates shall be so constructed that they can be securely closed. Following the completion of the pipeline construction, gates shall be removed and fences restored to their condition prior to the beginning of said construction or if landowners so elect said gates shall be left in place.

B. Clearing operations shall be conducted to comply with all conditions and special provisions included in each of the respective right-of-way agreements secured by Company and shall comply particularly with respect to the limits specified in the Agreement and with the least possible damage to shrubbery, crops, wells, springs, valuable trees, timber and any structures existing thereon.

C. All brush and trees cut shall be disposed of or removed from the rights-of-way. Flammable debris if burned shall be burned at a safe distance from existing pipeline or other hazardous locations. Stumps of trees on said rights-of-way shall not project more than four (4) inches from the normal surface of the ground, and those in the pipeline ditch or trench shall be entirely removed so that in no instance will they come in contact with the pipe. All loose stumps, brush, boulders and other debris shall be removed so that the spoil bank from ditching operations will not fall on any foreign materials that might become mixed with the excavated soil. Merchantable timber and/or pulpwood shall be cut into lengths and neatly piled along the right-of-way for Company's disposition.

D. The right-of-way shall be graded in such manner as to best facilitate the laying of the pipeline and the doing of the Work.

E. In portions of the territory in which ditching, canalling and other similar work will be done, there may be pipelines or facilities owned by others buried beneath the surface of the land or laid under the surface of the water. On maps attached to the Contract Documents, Company has endeavored to indicate as many of these lines and

SPECIAL INSTRUCTIONS TO CONTRACTOR

facilities, if any, as to which it has knowledge and the approximate locations as Company has so far ascertained. Contractor is warned, however, that said maps are not guaranteed to be either accurate or complete in this respect; but on the contrary, are approximate and give only the best information Company now has as to the existence of such lines or other facilities and their locations, and Contractor shall be under the duty to ascertain and protect all hidden or buried pipelines or other facilities in the territory through which Contractor works, and any damage done to such lines or facilities, or any liability incurred in connection therewith shall be solely that of the Contractor. With respect to pipelines of others on the surface, it will be necessary to ditch, trench or canal underneath such lines and to properly protect and support the same, and any damage direct or consequential to such pipelines shall likewise be the sole responsibility and liability of Contractor. The cost of crossing underneath such lines and protecting and supporting same is included in the unit price for the laying of the Company's lines.

F. Where construction parallels an existing pipeline, utmost care shall be taken to prevent damaging the existing pipeline or jeopardizing its operation. In addition, where construction parallels an existing pipeline, the amount of overburden deposited over said line or lines shall be held to a minimum and shall be immediately removed down to original ground level at the request of the Engineer.

C-5 HAULING AND STRINGING ALL MATERIALS

A. This item shall include the receiving, loading, unloading, storing, handling, hauling and stringing of all materials from time of delivery of same to Contractor until the final installation of materials in the job or its return to a designated storage site.

B. Contractor shall obtain from the City, State Highway Commission, the Interstate Commerce Commission, Board of Supervisors and/or other regulatory agencies having jurisdiction, the necessary permits and certificates to permit Contractor to perform under these specifications and Contractor shall at Company's request furnish satisfactory evidence of compliance with all rules and regulations of such agencies.

SPECIAL INSTRUCTIONS TO CONTRACTOR

C. Where it is necessary to cross bridges and culverts in hauling an extra heavy load of materials to job locations, Contractor shall contact and work with representatives of the City, State Highway Department and Board of Supervisors having jurisdiction to prevent damage to such structures.

D. The unloading, hauling and stringing of pipe and other materials required for the completion of the gas line shall be done in such a manner as to prevent damage to same. The beds and bolsters of pipe trucks must be padded if hauling coated pipe, in order to prevent breaking of the insulation on the pipe. Pipe shall be transported to the right-of-way and unloaded as near as possible to the points where it is to be used, and shall not be unloaded and dragged along the right-of-way from central points without the consent of Engineer. Wrapped pipe shall not be dropped or otherwise handled in a manner that would damage the pipe or coating.

E. In distributing pipe and other materials along the route of the line, the workmen shall place the same in a neat and orderly manner, and at such locations as will not obstruct the free and unrestricted use of any highway, city street, roadways, drainage courses, culverts, and the lands along and adjacent to any right-of-way. Contractor shall string the pipe and other materials in such a manner as to cause the least interference with the normal use of the land crossed by the right-of-way. Gaps shall be left at intervals in the pipe as strung to permit the regular use of the land and the passage of equipment across the right-of-way, highway, streets, or alleys.

C-6 RACKING PIPE

A. Should Contractor desire to rack any pipe at the delivery points, or at any other locations, or in the event it becomes necessary to rack any pipe at any locations on account of difficulty in the securing of right-of-way easements or from any other causes, Contractor shall secure the site for such storage. No additional payment shall be made for any expenses in connection with the securing of these sites, the racking of pipe, or extra handling, caused by these operations.

B. Contractor shall rack the pipe in a manner that will prevent damage to same and shall maintain same in a safe and approved manner.

SPECIAL INSTRUCTIONS TO CONTRACTOR

C-7 DITCHING

A. In general, but subject to the terms of the right-of-way easements, and subject to such variations as are necessary or desirable in the opinion of Engineer to safeguard the public or to conform the new work to existing or anticipated improvements along the line, the minimum width of the ditch and the minimum depth of cover over distribution mains shall be as follows:

<u>Size of Pipe</u>	<u>Minimum Width of Ditch</u>	<u>Minimum Depth of Cover</u>
1"	4"	40"
2"	6"	40"
4"	8"	40"
6"	12"	40"
8"	16"	40"
10"	24"	40"
12"	24"	40"

B. Transmission lines shall have a minimum cover of forty (40) inches including installations under drainage ditches, public roads and railroad crossings.

C. Contractor shall carefully preserve all stakes set by Engineer, and Contractor shall be liable for any extra work on the part of Engineer due to his failure to maintain such stakes.

D. Ditch shall be carefully graded by hand where necessary to meet the above specifications and to provide an even bed for the pipe. At over bends and side bends, Contractor shall excavate the ditch as directed by Engineer to allow clearance between the inside bend of the pipe and the bottom or side of the ditch.

E. In instances where the distribution mains and transmission lines cross highways or railroads, the plans require that said crossings be bored instead of trenched. By boring, it is meant the construction of a bored cylindrical hole using dry boring equipment or other types of boring equipment if such equipment has been accepted by the railroad or Highway Department and Company. The hole

SPECIAL INSTRUCTIONS TO CONTRACTOR

that is bored shall be of such size that it will receive the casing with a snug fit.

F. Where necessary, the ditch shall be graded to pass under all pipe lines, road and railroad crossings, streams, trenches, irrigation ditches, or other obstructions as specified by Engineer; but, except at such locations, Contractor shall not excavate the ditch to a greater depth than specified by Engineer. Contractor shall so grade the approaches to these obstructions that excessive depth of cover on these approaches shall be kept to a minimum. On such sections of the line where the use of trenching equipment may result in unnecessary damage to properties crossed by the line, Engineer may require the trench to be excavated by hand.

G. Spoil bank from the ditching operations shall not be placed where drainage will be affected and shall be placed in locations acceptable to property owner.

H. Contractor shall complete the ditch to the line and grade established by Engineer, regardless of the type of soil or rock encountered, and regardless of the depth of excavation necessary. Contractor shall furnish all materials and supplies necessary for the completion and maintenance of the ditch, including water control, shoring, coffer dams, sacking and sheet piling as required.

I. All stumps and roots encountered in the ditch line shall be cut back far enough so that in no instance shall they come in contact with the pipe. No chips or parts of stumps shall be left in the ditch, and where stumps and roots have been cut out of the ditch line, earth shall be thrown into locations so as to cushion the pipe and eliminate any possibility of its coming into contact with stumps and roots.

J. In ditching where drain tile is encountered, the Contractor shall ditch the line below or above the drain tile, as may be necessary or practicable to protect the same as may be required by the property Company and his tenant. If and when any drain tile is damaged, cut or removed, Contractor shall immediately replace such drain tile with like kind and size to the satisfaction of property owner and his tenant so that drain line will or can continue to function properly.

SPECIAL INSTRUCTIONS TO CONTRACTOR

K. Excavation walls higher than four feet must be shored or sloped to eliminate danger of cave-ins before anyone is allowed to enter the excavation. See OSHA Regulations: Department of Labor, Bureau of Labor Standards, Safety and Health Regulations for Construction.

C-8 LINING, TACKING AND WELDING

A. Electric welding will be required on all pipe and fittings larger than 2". Oxy-acetylene welding will be generally used on pipe smaller than 2". Electric welding can be used on service tees if desired. Either electric or oxy-acetylene welding may be used on 2" pipe and fittings.

B. All welding and burning equipment, such as welding machines, beveling machines, acetylene generators, welding rods, welding and cutting torches, regulators, etc., are to be furnished by the Contractor and shall be satisfactory to the Engineer. Any such equipment that is not satisfactory shall be discarded and satisfactory equipment substituted therefore.

C. Cutting and burning supplies such as oxygen, acetylene, carbide, etc., shall be furnished by the Contractor, and these supplies shall be satisfactory to the Engineer. Any material that is not satisfactory shall be discarded and satisfactory material substituted therefore.

D. The Contractor shall use only welders that have been qualified under API Standard 1104 in the particular welding procedure or procedures to be used and who have been approved by Company.

In order to keep welders qualified and to prove the workmanship of each welder, the Engineer will be privileged to require additional or future tests. Any welder doing consistently poor work shall be immediately released by the Contractor.

E. Each weld may be visually inspected by Engineer at the option of the Company and on lines to be operated at high pressure radiographic inspection may be made of each butt weld.

F. No weld shall be acceptable which does not conform to the specifications of API Standard 1104. All welds must be

SPECIAL INSTRUCTIONS TO CONTRACTOR

free of cracks, un-repaired burn-through, and other defects; and must have adequate penetration and present a neat workmanlike appearance. Under-cutting adjacent to the final bead on the outside of the pipe shall not exceed 1/32" in depth or 12½% of the pipe wall thickness, whichever is smaller; and there shall not be more than 2" of under-cutting in any continuous 12" length of weld. At no point shall the crown surface be below the outside surface of the pipe, nor should it be raised above the parent metal by more than 1/16".

G. Welds found to be unacceptable either by visual or radiographic inspection will be removed. Defects, except cracks, in the root and filler beads may be repaired with prior authorization of Company. Defects, except cracks in the cover pass, may be repaired without prior authorization by the Company. Cracks shall not be repaired.

Before repairs are made, injurious defects shall be entirely removed to clean metal. All slag and scale shall be removed by wire brushing.

H. Deflections of up to 3" in the longitudinal axis of two sections of pipe being welded together will be permitted. Any deflection over 3" is considered a miter weld and will not be permitted except in cases where approval of Engineer has been obtained.

I. Special care will be taken to see that welding is not subjected to blowing sands, high winds or stormy weather, and care shall be taken to see that the welds are not subjected to sudden variations of atmospheric temperature during welding. Welding shall not be performed when in the judgment of the Engineer the weather is unsatisfactory.

J. Before tack-welding the joints, the ends of the pipe shall be cleaned with wire brush and filed to remove all foreign matter such as rust, scale, paint, and primer. Bevels which have been produced by flame cutting shall be cleaned of all heavy oxide and slag, but the thin, blue-black oxide coating found on all flame cut surfaces need not be removed. Flame cut ends of all line joints shall be square with the pipe so that correct spacing is obtained after joint alignment.

K. Tack welds shall be sufficient in number, however, to assure proper joint alignment and spacing at all times

SPECIAL INSTRUCTIONS TO CONTRACTOR

during the process of making the weld. Tack welds shall not exceed 3/16 inches thickness and shall be free from pinholes. All welding slag, scale and oxides shall be removed from tack welds before welding. After tack weld has cooled down, the space of any point around the Joint shall be within a maximum of 1/8 inch and a minimum of 1/16 inch.

L. When rolling welds on pipe each bead shall be applied completely around the pipe and shall be thoroughly cleaned with a scale hammer and wire brush of all scale, dirt, coating, slag, etc., prior to the application of the next bead.

M. For position welding, each joint shall be held in alignment with a satisfactory clamp while the pipe is being lined and tacked. The first weld bead must be completed around the pipe, and may be applied by two welders working simultaneously on opposite sides of the pipe. The line up clamp shall be left in position. After removal of clamp, the remainder of first weld bead shall be completed before the welding proceeds to the next joint. Each bead shall be cleaned of all scale, dirt, coating, slag, etc., with a scale hammer and wire brush prior to the application of the next beads.

N. There shall be no artificial cooling applied to welds.

O. The line shall be tested in accordance with instructions given hereinafter. Joints which leak under test shall be repaired or cut out as directed by Engineer.

P. All sections of tacked or welded pipe shall be closed at night to prevent animals or foreign material from entering the pipeline or pipe section.

C-9 JOINING OF MATERIALS OTHER THAN BY WELDING

Piping must be installed so that each joint will sustain any longitudinal pull out or thrust forces caused by contraction or expansion of the piping or by anticipated external of internal loading.

The procedures for making joints by flanged, threaded, or heat fused connections are described below.

SPECIAL INSTRUCTIONS TO CONTRACTOR

FLANGED CONNECTIONS. Before any flange connection is made, the face of the flange must be clean. Use gasket with proper pressure rating, match flange, inserting gasket properly aligned, insert bolts, tighten nuts finger tight or snug. Make sure bolt holes are aligned and begin tightening bolts one quarter to one half turn each bolt, moving to the opposite side of same flange each time a bolt is tightened. Continue tightening in this manner until all bolts are tight.

THREADED JOINT. The following is required to make a gas tight threaded joint connection. Remove all rust or foreign matter from the threads. Apply pipe Joint cement to the male threads. Mate the threaded joints and make up with wrench until tight. Care should be taken not to over tighten. It is important that the proper size wrench be used. A good rule of thumb for selecting proper size wrenches is as follows:

1/2" and 3/4"	10" or 14" Pipe Wrench
3/4" and 1"	14" or 18" Pipe Wrench
1" or 1 1/4"	18" or 24" Pipe Wrench
1 1/4" or 1 1/2"	18" or 24" Pipe Wrench
1 1/2" and 2"	24" or 36" Pipe Wrench

GROUND JOINT UNION INSTALLATION. Each ground joint union comes from the factory as matched halves. When used they should be used in such a way that each half will match the same way as it came from the factory. The face of each half should be clean before assembling. Make sure it is faced and aligned then tighten with proper size wrench.

C-10 PROTECTIVE COATING - GENERAL

A. All pipe, casing, valves, fittings, vent lines, pipeline appurtenances, etc., that are to be installed underground shall be coated with an approved protective coating material.

SPECIAL INSTRUCTIONS TO CONTRACTOR

B. The Contractor shall furnish all enamel kettles, cleaning, priming and coating equipment, brushes, slings, buckets, thermometers, high voltage electric holiday detector (an approved type), fuel and miscellaneous tools necessary for the application and testing of the pipeline protective materials.

C. Before applying primer, the outside of the pipe shall be thoroughly cleaned to the satisfaction of the Engineer, to remove all dirt, mill scale, rust, welding scale, and other foreign materials. When oil or grease is present on the pipe, the oil and grease shall be removed by wiping the surface on the successive pipes with clean rags dipped in coal-tar naphtha, primer thinner or other suitable solvents.

C-11 FIELD COATING PIPE AND PIPE JOINTS WITH APPROVED HOT OR COLD APPLIED TAPE

A. Remove a minimum of 2 inches of Kraft paper or asbestos felt adjacent to the field joints.

B. Clean dirt, mill scale, welding flux, and foreign material from the Joint using a wire brush and rags.

C. Apply one coat of primer to the exposed surface of the pipe including the portion of pipe coating from which the Kraft paper was removed. (NOTE: If the pipe is wet from dew, rain, etc., it shall be allowed to dry by sunlight or heat applied from artificial source.)

D. Hot or cold tape is then applied over the wet surface of primer, being spiral wrapped so as to have a one half-inch lap. The surface of the hot applied tape that will be next to the pipe is heated with a butane torch or a similar source of low temperature heat by passing the flame rapidly over the surface of the coating. The wrapping should be heated only in sufficient area at one time that it will still be sticky when applied to the pipe surface.

E. After the joint is completely wrapped, making sure that there is no exposed pipe, the entire outer surface of hot applied wrapping shall be lightly flashed with the torch to seal the coating.

F. These joints, if 2" and larger, will be inspected for holidays with an approved high voltage holiday detector.

SPECIAL INSTRUCTIONS TO CONTRACTOR

C-12 HOLIDAY INSPECTION

A holiday is a discontinuity of coating that exposes the metal surface to the environment. The inspection of all coated steel pipe 2" and larger in diameter for holidays with an approved holiday detector is required before installation.

The voltage required to adequately detect holidays is dependent on the type of protective coating. The coatings most frequently used are thin-film, X-Tru coat, and Tapecoat CT. Thin-film coating requires 125 volts per mil of coating, and the voltage required for X-Tru coat and Tapecoat CT is approximated from the formula.

$$\text{Voltage} = 1,250 * vT$$

where T is the average coating thickness in mils (0.001 inch).

The following checks should be made on the detector before each use:

1. Check to insure that the detector is OFF.
2. Select the appropriate switch settings for the particular coating. To adjust the HI/LO switch on the SELECTOR, unscrew the protective cap. A screwdriver is required to make this adjustment. The voltage switch setting is adjusted using the same procedure.
3. Connect the ground and high voltage cables to the detector by inserting and turning clockwise.
4. Attach the wand handle to the voltage cable.
5. Attach the electrode to the voltage probe assembly and apply to the pipe. Intimate contact should exist between the pipe and the electrode.

A good ground is necessary to have a reliable inspection. The pipe to be inspected must be grounded to the earth at some point. If an individual joint of pipe is to be inspected it must be grounded. The speed that the detector electrode travels over the pipe should be moderate to allow adequate inspection. Periodically check the operation of the detector by contacting the wand to the edge of the

SPECIAL INSTRUCTIONS TO CONTRACTOR

coating where bare pipe exists. A spark and signal should occur. If no signal occurs the ground return is of high resistance, and it may be necessary to connect the ground wire to the pipe.

The holiday detector and its accessories should be kept clean and dry, especially the electrical contacts. The case can be cleaned with a soft cloth moistened with kerosene and then wiped dry. Do not use solvents (i.e., lacquer thinners, methyl ethyl ketone).

If LOW voltage output occurs check the following:

1. Position of voltage selector switches.
2. Battery charge.
3. Look for "parted" conductor in voltage probe and ground trail.

If NO voltage output occurs check the following:

1. Battery
2. Look for "parted" conductor in voltage probe and ground trail.
3. Battery contacts (be sure they are clean).

The battery should be charged nightly after each use, and ONLY use the battery charger provided. Best results are achieved when recharging is done at temperatures above 45° F. The battery can be recharged in or out of the detector.

Recharging the battery nightly will extend its life. The battery should be stored at room temperature (68° F or 20° C) or below when not in use. Never store the battery in the discharged state, and recharge the battery at least every 30 days when not in use.

If any questions arise regarding the operation of the detector, contact Operating Services.

C-13 LAYING PIPE, SUPPORTS AND ANCHORS

LAYING PIPE

SPECIAL INSTRUCTIONS TO CONTRACTOR

A. The ditch shall be cleaned of clods, skids, and other debris immediately before the pipe is lowered. When the ditch is through rock, gravel, or like material, the bottom of same shall be padded by filling with sufficient earth to form a cushion on the bottom of the ditch before the pipe is lowered or lime dust may be used as the padding.

B. The pipe shall not be lowered into the ditch before the coating has hardened.

C. In general, only belt slings and/or padded tongs shall be used for lowering pipe into the ditch. The use of chains or wire rope shall not be permitted. During the lowering-in process the slope of the pipe from its position on the ditch shall be as gentle as possible. All pipe shall be lowered slowly and carefully, without jerking and special care shall be taken not to damage the coating.

D. The pipe shall be lowered into the ditch without unnecessary strain and so that the pipe rests evenly on the bottom of the ditch. Any sections of pipe not carefully lowered into the ditch shall be inspected for damage to coating. Any damage done shall be repaired by Contractor. The Engineer shall be the sole judge as to the condition of the coating.

E. After lowering, the pipe must be made secure to prevent floating, should water enter the ditch. Ends of sections being lowered shall be capped to prevent water, dirt, or other foreign matter from entering the line. Contractor shall, at his own expense, cut out any extra slack from the line and weld the resulting two ends of the line together.

F. Each field bend in steel pipe must comply with the following:

1. A bend may not impair the serviceability of the pipe.
2. On pipe containing a longitudinal weld, the longitudinal weld must be as near as practicable to the neutral axis of the bend.
3. A bend on pipe that is 12 inches or more in nominal diameter must not deflect the pipe more

SPECIAL INSTRUCTIONS TO CONTRACTOR

than 1-1/2" in any length of pipe equal to the diameter.

4. For pipe more than 4 inches in nominal diameter, the difference between the maximum and minimum diameter at a bend may not be more than 2-1/2 percent of the nominal diameter.

Each bend must have a smooth contour and be free of mechanical damage. Each circumferential weld of steel pipe that is subjected to stress during bending must be nondestructively tested.

Wrinkle bends are not permitted.

G. At stream crossings, or at other locations where it may be necessary to pull or drag sections of pipe into place, the coated pipe shall be protected in such manner as to prevent damage to the coating or to the pipe.

SUPPORTS AND ANCHORS

Each pipeline and its associated equipment must have enough anchors or supports to prevent undue strain on connected equipment and resist longitudinal forces caused by a bend or offset in the pipe.

Each exposed pipeline must have enough supports or anchors to protect the exposed pipe joints from the maximum end force caused by internal pressure and any additional forces caused by temperature expansion or contraction or by the weight of the pipe and its contents.

Each support or anchor on an exposed pipeline must be made of durable, noncombustible material and must be designed and installed as follows:

Free expansion and contraction of the pipeline between supports or anchors may not be restricted.

Movement of the pipeline may not cause disengagement of the support equipment.

Each underground pipeline that is being connected to new branches must have a firm foundation for both the header and the branch to prevent lateral and vertical movement.

SPECIAL INSTRUCTIONS TO CONTRACTOR

C-14 REPAIR ON STEEL PIPE

Each imperfection or damage that impairs the serviceability of a length of steel pipe must be repaired or removed. If a repair is made by grinding, the remaining wall thickness must at least be equal to either:

- (1) The minimum thickness required by the tolerances in the specification to which the pipe was manufactured; or
- (2) The nominal wall thickness required for the design pressure of the pipeline.

The Engineer will provide information on required wall thickness.

A "dent" is a depression that produces a gross disturbance in the curvature of the pipe wall without reducing the pipe wall thickness. The depth of a dent is measured as the gap between the lowest point of the dent and a prolongation of the original contour of the pipe.

Each of the following dents must be removed from steel pipe to be operated at a pressure that produces a hoop stress of 20 percent, or more, of Specified Minimum Yield Strength (SMYS):

- (1) A dent that contains a stress concentrator such as a scratch, gouge, groove, or arc burn.
- (2) A dent that affects the longitudinal weld or a circumferential weld.

A gouge, groove, arc burn, or dent may not be repaired by insert patching or by pounding out.

Each gouge, groove, arc burn, or dent that is removed from a length of pipe must be removed by cutting out the damaged portion as a cylinder.

C-15 MAIN LINE VALVE INSTALLATION

SPECIAL INSTRUCTIONS TO CONTRACTOR

A. All main line valve installations will be made only after the line has been cleaned. Lateral valves may be installed as pipeline is constructed.

B. All lateral valves are to be installed. After installation has been completed and coated with protective coating, the area shall be back-filled, tamped and graded. Care shall be taken not to injure the lines or protective coating.

C-16 INSULATING FLANGES

A. Insulating flanges, for the control of pipeline corrosion, shall be installed in the pipeline at points designated by the Engineer.

B. In general, it is anticipated that the point of installation of these flanges will be designated before backfilling; however, in case additional insulating flanges are designated by Engineer after backfilling has been completed along the affected portion of the line, re-excavation and backfill will be classified and paid for by the Company.

C. Test wires shall be installed on all insulating flanges and insulating compression couplings.

C-17 WELDING PIPE BONDS

A. The Contractor shall connect by the "Cadweld Process", copper bonds and test leads onto the pipe at the locations shown on drawing or as directed by the Engineer. The pipe surface should be thoroughly cleaned to a bright metal finish where each attachment is to be made. Insulation on ends of all bond or lead wire shall be cut back two (2) inches, and the wire thoroughly cleaned.

Nicks, kinks or notches in wire will not be permitted. After attaching wire to pipe, the wire shall be laid along the pipe surface for a distance of 4 to 6 inches, and then sloped away from the pipe. Protective coating shall be repaired around point of attachment, using same type of coating materials specified for the pipe in the particular location, with care being taken to obtain a good, watertight seal around the wire.

SPECIAL INSTRUCTIONS TO CONTRACTOR

B. When backfilling pipe line, care shall be taken to avoid damage to wire. Wires shall be laid in the ground with sufficient slack so that settlement of backfill will cause no damage.

C-18 SERVICE INSTALLATION

A. Services shall be of either coated steel or plastic, unless exceptions are made in individual cases by the Engineer.

B. Steel or plastic services shall be installed according to specifications supplied and/or by special instruction.

C. The length of a service line shall be defined as the maximum length of the service pipe below or following the surface of the earth and shall include that portion of the riser that is vertical or protruding above the earth's surface.

D. Services shall be connected to the top of the main in all instances where a standard service connection is made.

E. The size of the tap shall be as follows:

<u>Service Line Size</u>	<u>Standard Size Tap</u>
3/4"	3/8"
1"	1/2" or 5/8"
1 1/4"	7/8"
2"	1 3/8" or 1 1/2" or 1 3/4"

F. The service riser shall be installed vertically.

1. It shall be installed approximately but not less than twelve (12) inches from the finished wall of the building.
2. Where possible, the riser for a single outside meter shall be located to the left (when facing the building) of the fuel line where it emerges from the building wall. For domestic sets, the distance "to the left" should be approximately eighteen (18) inches.

SPECIAL INSTRUCTIONS TO CONTRACTOR

3. The service riser shall not be brought up under windows unless a fuel line stub-out has already been installed making it necessary to bring up the riser at a location under a window.

G. The stopcock on the outside service riser should be a minimum of fifteen (15) inches above the surroundings finished grade.

H. When a service is connected to a coated main which is eight (8) inches or under in diameter, the main shall be cleaned all the way around and approximately eight (8) inches on each side of the location of the service connection before welding. On tying into coated mains more than eight (8) inches in diameter, it is sufficient to remove a patch ten (10) to twelve (12) inches in diameter to expose the pipe for making the service connection.

I. If the main is bare, that is, if it either has no coating or its original coating has so deteriorated as to be of no value, and a steel service is laid, the same coating as on main or the coating specified by Engineer for field joints shall be applied for a distance of approximately twelve (12) inches on each side of the service connection. Any bare portion of a coated main and service (including the service connection) shall be protected as specified by Engineer from main to service riser before the installation is ready for backfilling.

J. That portion of a service that parallels a building wall should not be installed closer than twelve (12) inches to the building foundations. Wherever possible when it is necessary to install the service closer to the building foundation, the depth of the excavation shall not exceed eighteen (18) inches or the depth of the building foundation.

K. Unless local ordinances provide otherwise, that portion of a service which extends between the curb lines of a street shall at no point be less than eighteen (18) inches below the flow line of the gutter under which it passes, except when the location of sub-structures in the street prevents it. That portion of the service line which extends under unpaved roadside ditches shall not be less than twenty-four (24) inches below the flow line of the ditch. That portion of the service which is laid on

SPECIAL INSTRUCTIONS TO CONTRACTOR

private property shall be at least eighteen (18) inches below the finished grade of the property.

L. That portion of a service between the main and the street property line shall be installed at right angles to the street property line. That part laid on private property shall be installed parallel to the building walls except, in extraordinary circumstances.

M. A complete service installation will include pneumatic tamping whenever and wherever required.

N. Each service line must be properly supported on undisturbed or well-compacted soil, and material used for backfill must be free of materials that could damage the pipe or its coating.

O. Where condensate in the gas might cause interruption in the gas supply to the customer, the service line must be graded so as to drain into the main or into drips at the low points in the service line.

P. Each service line must be installed so as to minimize anticipated piping strain and external loading.

Q. A plastic protective sleeve, not less than twelve (12) inches in length, shall be installed over a juncture of a plastic service line and plastic tapping tee or steel valve tee. The sleeve should cover as much of the tee outlet as possible and should fit snugly. If necessary, the tee outlet may be wrapped with tape to achieve a snug fit.

C-19 BACKFILLING

A. Before backfilling, the line shall be inspected to make sure that no skids, brush, stumps, or other debris are in the ditch, and no such materials or debris shall be permitted to be backfilled into the ditch. Backfilling shall be so conducted that the ditch shall be neatly backfilled and all of the material excavated either placed in the ditch or bermed over the ditch. Rock, gravel, boulders, or like materials shall not be backfilled directly onto the pipe where such materials are encountered. Contractor shall provide, and shall haul if necessary, sufficient earth or sand to be first backfilled around and over the pipe to form a protective padding or

SPECIAL INSTRUCTIONS TO CONTRACTOR

cushion between the pipe and the rock, gravel, boulders or other such materials in the bottom and sides of the ditch and to a depth of six (6) inches over the top of the pipe. Such earth cushion shall be thoroughly tamped before further backfilling.

B. In all cases where the pipe line crosses public or private highway, roadway, street, alley, or pedestrian-way, the workmen shall, immediately after the pipe is laid, backfill the crossing, so that its use by the public will not be hindered or restricted. Unless subject to special requirements the backfill at all crossings of city streets and alleys, public or private highways, private roadways or pedestrian-ways, shall be deposited in layers not more than six (6) inches in thickness, each such layer being thoroughly tamped before the next layer is deposited, up to a level of approximately six (6) inches below the finished grade of the roadway. The upper, or surface, layer shall be carefully filled with material similar and equal to the original surfacing material removed, and thoroughly tamped. The backfill in all such crossings shall be maintained until the final acceptance, keeping the surface of the backfill smooth and flush with the original road or ground surface on each side of the trench.

C-20 CITY STREETS AND ALLEYS

A. At points where the route of the gas lines follows or crosses city streets and alleys, the depth to which the trench is to be excavated and the methods used in excavating and backfilling shall be subject to the requirements of city ordinances, the city engineer or other authorized representatives of the city.

B. The Contractor shall assume full responsibility and accept all liabilities for blocking roadways and driveways both public and private and must notify and obtain permission from the city engineer or other authorized representatives and the city fire department before ditching on each or any of the city's streets or alleys and shall comply with all local and state regulations regarding such matters.

C. Insofar as is practicable, service lines and distribution lines that cross paved city streets shall be

SPECIAL INSTRUCTIONS TO CONTRACTOR

bored. Paving may be broken only at the direction of the Engineer.

C-21 PAVED HIGHWAY AND RAILROAD CROSSINGS

- A. At points where the pipeline crosses under or along paved highways or railroad tracks, Contractor shall be governed in all his operations by the requirements of the proper officials of the Federal and State Highway Departments and/or of the railroad company as to methods used in making the excavations for and installing the pipeline. These requirements shall be furnished by the Engineer.
- B. The Engineer shall obtain all permits from the Highway Commission and/or railroad company.
- C. In instances where distribution mains and transmission lines cross highways or railroads, such crossings shall be bored instead of trenched. By boring, it is meant the construction of a bored cylindrical hole using dry boring equipment or other types of boring equipment if such equipment has been accepted by the railroad or Highway Department and Company. The hole which is bored shall be of such size that it will receive casing or carrier pipe with a snug fit.
- D. Where required at highway and railroad crossings, pipe shall be laid in coated casing, the diameter and length of which shall be specified by the Engineer in conjunction with the above mentioned officials. The sections of vent extending above the ground surface will be coated with two coats of aluminum paint.
- E. Contractor shall notify the proper authorities as required before starting this work so that their representatives can be present, if necessary. Care shall be taken not to block traffic while such crossings are being installed. The end of casing shall be vented and plugged. All pipe laid in casing shall not have a change in direction or angle within the limits of the ends of the casing. Precaution must be taken and methods pursued during the installation of the pipeline in the casing to avoid damaging the coating of the pipeline. If the coating of the pipeline is damaged during its installation in the

SPECIAL INSTRUCTIONS TO CONTRACTOR

casing, it shall be removed and the damaged coating repaired.

C-22 CROSSINGS UNDER CANALS AND OTHER WATERWAYS

A. Should the line cross various rivers, swamps, creeks, bayous, canals, and other waterways, the following instructions shall apply:

B. The installation of lines at those crossings shall conform strictly with all laws and regulations applicable thereto of any governmental body, state, county, agency, etc., having jurisdiction. The Company will furnish copies of permits for these crossings, and both the completed work and the methods used in the construction of the same shall conform strictly to the conditions of such permits.

C. The work contemplated across these sections shall not be considered completed, as completion of the work contemplated is otherwise contractually provided for, until the authorized representative of such governmental bodies, agencies, engineers, etc., having jurisdiction shall have certified approval of such work in writing in accordance with the permits above described and in accordance with the present existing laws and regulations which govern.

D. Crossings on waterways not under the jurisdiction of any governmental body shall be completed as shown on the drawings and as directed by Engineer. The excavation across these streams shall be completed to the grade shown on drawings. On crossings, it is necessary to bury the line beneath the bottom and it must lie evenly in the trench for the entire distance and shall not lie across stumps, logs, shell, mud, or sand banks. In no case shall a line be suspended across channels or holes.

E. Crossings not enumerated in the Description of Work shall be constructed as a part of the general pipeline construction and under the terms and conditions applicable thereto.

C-23 TESTING, CLEANING, PURGING

SPECIAL INSTRUCTIONS TO CONTRACTOR

A. All new or replacement mains, services and other pressure-containing structures shall be tested before being placed in service to substantiate proposed maximum allowable operating pressure and to locate and eliminate leaks. Test procedures will be prescribed by the Company in accordance with the Minimum Federal Safety Standards.

B. All pipe, including that used in above ground structures and that used in tying-in new mains, must be tested. Where it is not practicable to test these sections of pipe with the main, they shall be given a pre-installation test at the same pressure as the main. Each weld used to tie-in a section of pipeline or main is exempted from the test requirements; however, these welds shall be soap tested after being put in service and before they are wrapped in the protective coating.

C. All mains, services, and structures shall be absolutely clean before final tests are started. Pipeline scrapers shall be used when necessary to remove foreign matter. At least two (2) scraper runs will be made in all mains four (4) inches and larger in size. Lines smaller than four (4) inches will be scraped and swabbed as needed for cleaning or when other circumstances make it advisable. Lines should be scraped prior to installing valves and other fittings that would not allow the passage of a pipeline scraper. All necessary valves, fittings, etc., for a complete job shall be installed after scrapers have been run in the line and prior to final testing. The Contractor shall furnish scrapers or "pigs" of a type acceptable to the Engineer.

D. Contractor will furnish equipment, labor, etc., for installation of service tees, blow-offs, test nipples, purging nipples, valves, blind flanges, gauge connections, bull plugs, etc., necessary to provide for the required testing and purging of facilities installed under this contract.

E. Test shall be made with air or nitrogen unless specified otherwise by Engineer.

F. Mains that will operate at pressures of one hundred (100) psig or less will be tested at one hundred (100) psig. Testing instructions for mains that will operate at higher pressure will be

SPECIAL INSTRUCTIONS TO CONTRACTOR

specified by the Engineer. The duration of the test, unless otherwise specified by the Engineer, shall be twenty-four (24) hours with no loss in pressure, due consideration being given to temperature change.

G. Service lines constructed from new mains may be tested along with the mains. Service lines over two (2) inches in size shall be tested in accordance with the requirements for testing mains. Steel service lines two (2) inches and smaller to operate at pressures up to one hundred (100) psig or plastic service lines to operate up to sixty (60) psig shall be given a stand-up air pressure test of not less than one hundred (100) psig for at least five (5) minutes before being placed in service. Steel service lines to operate at no more than forty (40) psig or plastic service lines to operate at not more than thirty three (33) psig may be tested at a pressure of not less than fifty (50) psig for at least five (5) minutes before being placed in service. These services will be specifically designated by the Engineer. Service lines to operate at pressures more than one hundred (100) psig shall be tested in accordance with instructions from the Engineer.

H. Each existing service line operating at a pressure in excess of one (1) psig that is taken out of service for any reason must be tested in the same manner as a new service line before being returned to service. Each existing service line operating at less than one (1) psig that is taken out of service for any reason shall be tested as required by the Engineer before being returned to service.

I. In each test, the Contractor shall provide the necessary blow-offs and will isolate sections of the mains where necessary for blowing and purging with gas. Contractor will reconnect the lines after the test.

J. The ends of the section being tested, whether the complete job or a portion of the job shall be closed by valves, bull plugs, or other devices approved by the Engineer. After the line has been tested according to instructions and no pressure loss or leakage has occurred the pressure may be blown down.

K. If the line or structure being tested should fail to hold the test pressure, the cause of leakage should immediately be located and removed or replaced as

SPECIAL INSTRUCTIONS TO CONTRACTOR

instructed by the Engineer in accordance with these Specifications. After necessary repairs have been made a new pressure test will be made according to the same instructions as for the first test. As many of these tests will be run and repairs made as is necessary to complete a satisfactory test.

L. The Engineer shall witness the test results on all lines to operate at more than one hundred (100) psig. On lines to operate at one hundred (100) psig or less, the Contractor shall, at the discretion of the Engineer, certify in writing that the test results were satisfactory.

M. After the completion of satisfactory tests, the line shall be purged and placed in service. As required by Engineer, Contractor shall uncover and prepare line for blowing and shall, after completion, reconnect and backfill the line in the locations where it has been blown. Company will furnish a reasonable amount of gas for blowing the line, but Company will not furnish gas to blow water or other unnecessary foreign matter out of the line.

N. Where one or more sections of line were tested separately and these sections are then connected for placing the line in service, all welds, valves, fittings, joints, and connections that were not subjected to the pressure test shall be tested in accordance with paragraph "B" of this section.

O. Sections of pipe extending across streams, bayous, canals, other waterways, or swamps, and sections of pipe extending beneath highways, roads or railways and ally section of pipe, where in the opinion of Engineer a failure in the pipe welds or connections would be dangerous to the public or would be difficult and expensive to repair after installation, will at the option of the Engineer be given a preliminary air pressure test prior to installation. Such sections shall be plugged and tested with air pressure of one hundred (100) psig and, while this pressure is maintained, all welds and connections shall be tested with soapsuds. Defects found during this test shall be repaired by Contractor, and the sections tested again until a satisfactory test is secured. All line stopper fittings shall be subjected to a pressure of one hundred (100) psig or a pressure approved by the Engineer and tested with soapsuds prior to drilling the pipeline.

SPECIAL INSTRUCTIONS TO CONTRACTOR

The making of any preliminary tests will in no way relieve Contractor from again testing these sections as required in the final test.

P. All purging operations will be done under the supervision of Engineer and/or according to Engineer's directions and instructions, and during regular company working hours.

C-24 OPERATIONS INVOLVING NATURAL GAS UNDER PRESSURE

All operations involving natural gas under pressure will be handled under the direction of Company's representative. Contractor will furnish line stopping equipment. Contractor will furnish necessary labor and equipment for operation of line stopping equipment. All operations involving natural gas under pressure and the use of line stopping equipment or other types of equipment involved in natural gas under pressure, where in the opinion of the Engineer, Company's personnel should be involved, will be performed on a regular company working day during regular working hours.

C-25 INSTALLATION OF PLASTIC PIPE

A. Plastic pipe and tubing shall be installed in accordance with the following Specifications in addition to the applicable Specifications under the various other Articles of the Construction Specifications.

B. Care shall be exercised to avoid rough handling of plastic pipe and tubing. It shall not be pushed or pulled over sharp projections, dropped, or have other objects dropped upon it. Caution shall be taken to prevent kinking or buckling, and any kinks or buckles which occur shall be removed by cutting out as a cylinder.

C. Care shall be exercised to protect the plastic pipe from fire, excessive heat, and harmful chemicals.

D. Plastic pipe shall not be installed above ground.

E. Plastic pipe shall be laid on undisturbed or well-compacted soil. If plastic pipe is to be laid in soils which may damage it, the pipe shall be protected by suitable rock-free materials before backfilling is

SPECIAL INSTRUCTIONS TO CONTRACTOR

completed. Plastic pipe shall not be supported by blocking. Well-tamped earth or other continuous support shall be used.

F. The pipe should be installed with sufficient slack to provide for possible contraction. Cooling may be necessary before the last joint is made, under extremely high temperature conditions.

G. When long sections of pipe that have been assembled alongside the ditch are lowered in, care shall be exercised to avoid any strains which may overstress or buckle the pipe or impose excessive stress on the joints.

H. Plastic pipe joints shall be made by heat fusion and the use of socket or butt fused couplings. Socket or butt fused tees shall be used in all cold laterals tie-ins. A socket or butt fused cap shall be used on the end of each extension.

I. Plastic mains shall be joined to steel mains through the use of either compression couplings or transition fittings. If a compression coupling is used, a metal stiffener shall be inserted in the end of the plastic main and the coupling shall be bonded to the steel main. All plastic to steel joints shall be wrapped with cold applied tape.

J. A tracer wire SHALL NOT be installed around plastic mains and service lines to facilitate location with a pipe locator. The wire shall be laid parallel.

K. Changes in direction of plastic pipe may be made with bends, tees, or elbows under the following limitations:

1. Plastic pipe and tubing may be deflected to a radius not less than the minimum recommended by the manufacturer for the kind, type, grade, wall thickness, and diameter of the particular plastic used. This dimension for a particular pipe size shall be specified by the Engineer.
2. The bends shall be free of buckles, cracks, or other evidence of damage.

SPECIAL INSTRUCTIONS TO CONTRACTOR

3. Changes in direction that cannot be made in accordance with (1) above shall be made with elbow type fittings.
4. Miter bends are not permitted.

L. Injurious gouges or grooves in plastic pipe shall be removed by cutting out the damaged section as a cylinder and replacing it with a good section.

M. Backfilling shall be performed in a manner to provide firm support around the pipe. The material used for backfilling shall be free of large rocks or pieces of pavement, or any other materials that might cause damage to the pipe. Backfilling, using heavy equipment, shall not be done until the pipe has twenty-four (24) inches of cover and is under a pressure of fifteen (15) psi.

N. The minimum depth of cover over plastic mains shall be as specified on page 14.

C-26 INTENT OF SPECIFICATIONS

It is the spirit and intent of these Specifications, and any drawings accompanying them and forming a part of the contract, to provide for the complete installation of the transmission or distribution piping system described in the Agreement for the transmission or distribution of natural gas in accordance with the best modern practice for construction of these lines and in accordance with the Minimum Federal Safety Standards for the transmission of natural and other gas by pipe lines. In the case of details which it is not possible to specify fully, or of inadvertent omissions from the Specifications, or of inadvertent inclusions therein, it is understood that their intent and purpose, regardless of such error, must be carried out in all respects, and the performance of the work shall be in accordance with the best recognized practice and to the satisfaction of the Engineer.

C-27 GUARANTEE

SPECIAL INSTRUCTIONS TO CONTRACTOR

It is understood that the Contractor unconditionally guarantees his labor, welding, and other workmanship and materials furnished by him for a period of twelve (12) months following final acceptance of the work. Any defects that appear during this time shall be remedied within a reasonable time after notification of the Contractor by the Company and at no expense to Company.

WORK SITE SAFETY AND SECURITY

A. SAFETY

1. CONTRACTOR agrees that any safety-related assistance or initiatives undertaken by COMPANY will not relieve CONTRACTOR from responsibility for the implementation of, and compliance with, safe working practices, as developed from their own experience, or as imposed by law or regulation, and will not in any way, affect the responsibilities resting with CONTRACTOR under the provisions of this Agreement and to meet all safety requirements as specified by the Occupational Safety & Health Administration (OSHA), the Department of Transportation (DOT), and any other applicable state or federal safety and health laws or regulations.
2. In the event that a material safety data sheet (hereinafter "MSDS"), warning label, or other documentation concerning the use of hazardous chemicals at the Work Site, applies to any materials or equipment provided by CONTRACTOR as an aspect of the Work, such documentation will be provided by CONTRACTOR to COMPANY's Contract Coordinator prior to the commencement of any such Work.
3. CONTRACTOR will provide information to COMPANY regarding hazardous chemicals and/or consumable products that contain constituents listed in 40 CFR §372.65 used at COMPANY Work site. CONTRACTOR will report the amount of such material carried on and off the site, the amount actually used and the manner of use. CONTRACTOR will provide the maximum quantity of the material stored on site at any one time and if a waste material was collected, where it was disposed of (location name and address).

SPECIAL INSTRUCTIONS TO CONTRACTOR

4. CONTRACTOR will provide for the duration of this Agreement, at its sole expense, adequate first-aid facilities for members of CONTRACTOR Group.
5. CONTRACTOR acknowledges and agrees that, except as otherwise expressly authorized in writing by COMPANY's designated safety representative, appropriate protective equipment will be worn by any member of CONTRACTOR Group while on the Work Site. In addition, when any member of CONTRACTOR Group is performing Work which may expose that person to potential hazards, CONTRACTOR acknowledges and agrees that such person will wear appropriate clothing specific to and adequate for that exposure.
6. CONTRACTOR will take all reasonable precautions to prevent any accident in connection with the performance of Work, including, but not limited to, putting up and maintaining sufficient barriers and lights.
7. CONTRACTOR will report to COMPANY all accidents involving personal injuries (including death) and damage to property occurring directly or indirectly as a result of the Work performed by CONTRACTOR hereunder immediately, but in no event, no later than twenty-four (24) hours after the occurrence of any such accident.

B. SECURITY

1. COMPANY may supply such site security as it deems necessary and may specify to CONTRACTOR such additional security precautions and procedures at the Work Site as, in COMPANY's opinion, are reasonably necessary for the safety and security of COMPANY's personnel and property.

Work Site security by COMPANY, if any, will not provide personal policing of the materials, tools and equipment of CONTRACTOR Group. CONTRACTOR will assume sole responsibility for safeguarding such materials, tools and equipment.

2. It will be the affirmative duty of CONTRACTOR to ensure that CONTRACTOR Group assists in carrying out all security measures, to include reporting all information or knowledge of matters adversely affecting security to COMPANY's designated security personnel.

SPECIAL INSTRUCTIONS TO CONTRACTOR

3. COMPANY reserves the right to exclude any of CONTRACTOR's employees from the Work Site by denial of access, suspension or revocation of access authorization, preemptory expulsion, or by any other means, without notice or cause. Former COMPANY employees, and any of CONTRACTOR's employees who previously have been excluded from any Work Site, may be brought onto COMPANY property or facilities only if prior approval from COMPANY's Contract Coordinator is obtained.

4. COMPANY measures may also include investigations, whether by COMPANY or law enforcement officials. CONTRACTOR agrees to cooperate in such investigations and understands that COMPANY reserves the right to require anyone in CONTRACTOR Group to authorize appropriate agencies to release his or her criminal records to CONTRACTOR as a condition of either initial or continued permission for access to COMPANY property or facilities. Investigations may include searches of CONTRACTOR Group. Such searches may include searches of facilities assigned to CONTRACTOR Group, search of all Work Site areas and property at such Work Site area, searches of including, but not limited to, offices, lockers, desks, lunch boxes, packages and motor vehicles (regardless of ownership).

CONTRACTOR agrees to instruct its employees in the details of COMPANY's Work Site security policies and measures, both as specified in the Agreement and as hereinafter provided by COMPANY to CONTRACTOR.

Hardin County
No federal number available
JP02 047 6557901U
City of Elizabethtown Gas

Commonwealth of Kentucky
Transportation Cabinet
Department of Highways
District Seven Permits

Pavement Restoration

TC 99-13
Rev. 8/2014



GENERAL NOTES:

1. Fill extends to bottom of pavement structure.
2. Replace pavement and materials with existing type.
3. Fill material must be agitated during transportation and waiting.
4. If the sawed joints are less than 6' from an existing joint or break in pavement, remove entire slab to break or joint.
5. Dimensions X and Y are the excavation width and depth, respectively.
6. Dimension T is the thickness of the material.
7. The thickness of new pavement shall match the existing thickness over the excavation area.
8. Seal any joints with approved material.
9. Any disturbed traffic control markings (arrows, bike lane symbols, striping, etc.) shall be replaced to match existing conditions as per KYTC specifications.

CONCRETE PAVING

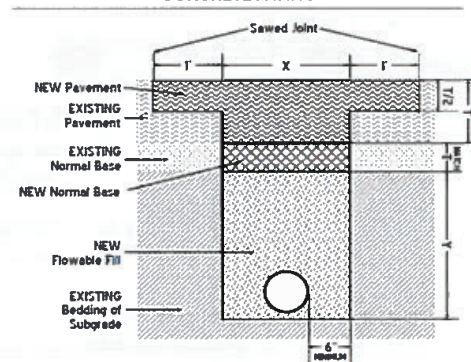

BITUMINOUS PAVING

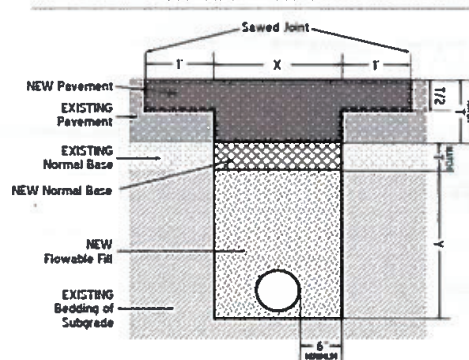

BITUMINOUS PAVING LESS THAN 2"

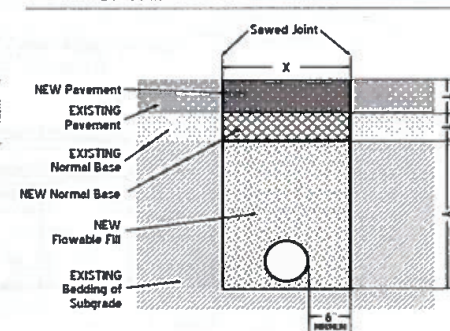

FLOWABLE FILL SPECIFICATIONS:

Flowable fill ingredients must meet the requirements of the Kentucky Department of Highways as set forth in the manual of standard specifications.

Proportioned as follows per cubic yard batch:

Cement	30 Pounds
Fly Ash, Class F	300 Pounds
Sand (SSD)	3,000 Pounds
Water (max)	550 Pounds

NOTES:

1. The proposed mixture shall be proportioned to obtain a minimum flow of 8 inches when tested with a 3 inch by 6 inch open ended cylinder modified flow test and meets acceptable strength requirements.
2. The mixture shall bleed freely within 10 minutes.
3. The mixture shall support a 150 pound person within 3 hours.
4. Flowable fill shall be in place for 2 hours prior to addition and compaction of cover material.

Standard Sanitary Sewer Bid Item Descriptions

S BYPASS PUMPING This item shall include all labor, equipment, and materials needed to complete a bypass pumping and/or hauling operation for diversion of sewage during sanitary sewer construction. Examples of such operations when bypass pumping and/or hauling may be necessary is during force main tie-ins, manhole invert reconstruction, insertion of new manholes into existing mains, or other similar construction. There may be more than one bypass pumping/hauling operation on a project. This item shall be paid for each separate bypass pumping/hauling operation occurrence as called out on the plans or directed by the engineer and actually performed. There will be no separate bid items defined for length, duration, or volume of sewage pumped or hauled in each occurrence. If a bypass pumping/hauling operation is called out on the plans; but, conditions are such that the bypass pumping/hauling operation is not needed or utilized, no payment will be made under this item. The contractor shall draw his own conclusions as to what labor, equipment, and materials may be needed for each bypass pumping/hauling occurrence. The contractor should be prepared to handle the maximum volume of the sewer being bypassed, even during a storm event. This item shall not be paid separately, but shall be considered incidental, when bypass pumping and/or hauling is needed during cast-in-place-pipe (CIPP) and/or point repair operations. Please refer to the Utility Company's Specifications. If the Company does not have specifications, KYTC's Specifications shall be referenced. This item shall be paid EACH (EA).

S CIPP LATERAL SERVICE INVESTIGATION This item shall include all equipment, materials, labor and incidentals necessary to enter the sewer in compliance with all safety/confined space requirements and perform the identification, assessment and pre-measurement of all existing and abandoned laterals for the placement of Cured-In-Place-Pipe lining. This item shall be in payment for all lateral service investigation for all sewer segments to be lined as a part of this contract. This bid item shall include bypass pumping when required. Please refer to the Utility Company's Specifications. If the Company does not have specifications, KYTC's Specifications shall be referenced. Payment for this item shall be LUMP SUM (LS).

S CIPP LATERAL REINSTATEMENT This item is to pay for installing a Cured-In-Place-Pipe liner in service laterals and service/mainline connections to stabilize structural defects and construction inadequacies. This bid item shall include all labor, equipment, materials and incidentals necessary to perform the service lateral reinstatement in accordance with the plans and specifications. Work under this item shall include bypass pumping, sewer flow control, pre-installation cleaning, sealing connections to existing sewer main, pre- and post- construction CCTV inspection and final testing of the CIPP system. This item shall also include the "top hat" required by the specifications. All CIPP lateral reinstatements shall be paid under this item regardless of the size or length of reinstatement. No separate bid items of varying sizes or length of CIPP lateral reinstatement will be provided in the contract. Please refer to the Utility Company's Specifications. If the Company does not have specifications, KYTC's Specifications shall be referenced. Payment for this item shall be EACH (EA) for each CIPP lateral reinstatement complete and ready for use.

S CIPP LINER This bid Item is to pay for rehabilitation of existing sanitary sewers using the Cured-In-Place-Pipe method. This bid item description applies to all CIPP sizes included in the contract.

All CIPP Liner items of all varying sizes shall include all labor, materials, customer notification, testing, necessary permits, ingress and egress procedures, bypass pumping, pre-construction video, sediment and root removal, dewatering, traffic control, erosion and sediment control, excavation pits, removal and replacement of manhole frames and covers as necessary to facilitate the lining work, sealing at manholes and service connections, clearing and grubbing, pipeline cleaning, re-cleaning and video inspection as many times as necessary, debris collection and disposal, root removal, pre- and post-construction video inspection, all digital inspection footage, final report preparation and approval, the cost of potable water from the Owner, required compliance tests, site restoration, site cleanup, sealing of liner at manholes, acceptance testing and all other rehabilitation work and incidentals not included under other pay items necessary to complete the rehabilitation per the plans and specifications. There will be no separate payment for acceptance testing of the lined pipe; but shall be considered incidental to this item. Pay under this item shall be by each size bid in the contract. Pay measurement shall be from center of manhole to center of manhole. Please refer to the Utility Company's Specifications. If the Company does not have specifications, KYTC's Specifications shall be referenced. This item shall be paid LINEAR FEET (LF).

S CIPP PROTRUDING LATERAL REMOVAL This item includes all equipment, materials, labor and incidentals necessary to enter the sewer in compliance with all safety/confined space requirements, remove a sufficient amount of the protruding tap to insure a proper and safe Cured-In-Place-Pipe lining insertion and perform pre-installation CCTV. This bid item shall include bypass pumping when required. Please refer to the Utility Company's Specifications. If the Company does not have specifications, KYTC's Specifications shall be referenced. Payment for this item shall be EACH (EA) for each protruding lateral removed.

S CONCRETE PIPE ANCHOR This item shall be constructed on the sewer pipe at the locations shown on the plans in accordance with sanitary sewer specifications and standard drawings. Payment for concrete anchors will be made at the contract unit price each in place complete and ready for use. Each concrete anchor of sewer pipe or force main shall be paid under one bid item per contract regardless of the sizes of carrier pipe being anchored in the contract. No separate bid items will be established for size variations. Please refer to the Utility Company's Specifications. If the Company does not have specifications, KYTC's Specifications shall be referenced. This item shall be paid EACH (EA) when complete.

S DIRECTIONAL BORE Payment under this item is made whenever the plans or specifications specifically show directional boring is to be utilized in order to minimize the impact of open cut for the installation of force main or gravity sewer under streets, creeks, and etc. Payment under this item shall include the specified bore pipe, labor, and equipment. No separate payment shall be made for bore pipe installed in the bore whether used as a carrier pipe or an encasement of a separate carrier pipe. This item shall also include pipe anchors at each end of the bore when specified to prevent the creep or contraction of the bore pipe. Carrier pipe installed within a bore pipe shall be paid separately under pipe items. Payment under this item shall not be size specific and no separate bid items will be established for size variations. The bore pipe sizes to be included under this item shall be as shown on the plans and/or in the specifications. Any and all directional bores in each contract shall be paid under one directional bore bid item included in the contract regardless of size. Please refer to the Utility Company's Specifications. If the Company does not have specifications, KYTC's Specifications shall be referenced. This item shall be paid LINEAR FEET (LF).

S ENCASEMENT CONCRETE Includes all labor, equipment, excavation, concrete, reinforcing

steel, backfill, restoration, and etc., to construct the concrete encasement of the sewer or force main as shown on the plans, and in accordance with the specifications and standard drawings. Payment under this item shall be in addition to the carrier pipe as paid under separate bid items. Carrier pipe is not included in this bid item. Any and all concrete encasement shall be paid under one bid item included in the contract regardless of the size of the carrier pipe or the volume of concrete or steel reinforcement as specified in the plans and specifications. No separate bid items will be established for size variations. Measurement of pay quantity shall be from end of concrete to end of concrete. Please refer to the Utility Company's Specifications. If the Company does not have specifications, KYTC's Specifications shall be referenced. This item shall be paid LINEAR FEET (LF) when complete.

S ENCASEMENT STEEL BORED This item shall include the steel encasement pipe size as specified on the plans and in the specifications, casing spacers, end seals, labor, and equipment to bore and install the encasement in accordance with the plans and specifications, complete and ready for use. The size shall be the measured internal diameter of the encasement pipe. The sizes of encasement to be paid under the size ranges specified in the bid items shall be as follows:

- Range 1 = All encasement sizes greater than 2 inches to and including 6 inches
- Range 2 = All encasement sizes greater than 6 inches to and including 10 inches
- Range 3 = All encasement sizes greater than 10 inches to and including 14 inches
- Range 4 = All encasement sizes greater than 14 inches to and including 18 inches
- Range 5 = All encasement sizes greater than 18 inches to and including 24 inches
- Range 6 = All encasement sizes greater than 24 inches

(Encasement sizes of 2 inches internal diameter or less shall not be paid separately; but, shall be considered incidental to the carrier pipe.) Payment under this bid item shall not include the carrier pipe. Carrier pipe shall be paid under a separate bid item. Please refer to the Utility Company's Specifications. If the Company does not have specifications, KYTC's Specifications shall be referenced. This item shall be paid LINEAR FEET (LF).

S ENCASEMENT STEEL OPEN CUT This item shall include the steel encasement pipe size as specified on the plans and in the specifications, casing spacers, end seals, labor, and equipment to open cut install the encasement in accordance with the plans and specifications, complete and ready for use. The size shall be the measured internal diameter of the encasement pipe. The size encasement to be paid under the size ranges specified in the bid items shall be as follows:

- Range 1 = All encasement sizes greater than 2 inches to and including 6 inches
- Range 2 = All encasement sizes greater than 6 inches to and including 10 inches
- Range 3 = All encasement sizes greater than 10 inches to and including 14 inches
- Range 4 = All encasement sizes greater than 14 inches to and including 18 inches
- Range 5 = All encasement sizes greater than 18 inches to and including 24 inches
- Range 6 = All encasement sizes greater than 24 inches

(Encasement sizes of 2 inches internal diameter or less shall not be paid separately; but, shall be considered incidental to the carrier pipe.) Payment under this bid item shall not include the carrier pipe. Carrier pipe shall be paid under a separate bid item. Please refer to the Utility Company's Specifications. If the Company does not have specifications, KYTC's Specifications shall be referenced. This item shall be paid LINEAR FEET (LF).

S FORCE MAIN This description shall apply to all PVC and ductile iron and polyethylene/plastic pipe bid items of every size and type, except those bid items defined as "Special". This item includes the pipe specified by the plans and specifications, all fittings (including, but not limited to, bends, tees, reducers, plugs, and caps), tracing wire with test boxes (if required by specification), polyethylene wrap (when specified), labor, equipment, excavation, bedding, restoration, testing, backfill, and etc., required to install the specified new pipe and new fittings at the locations shown on the plans, or as directed, in accordance with the specifications and standard drawings complete and ready for use. No additional payment will be made for rock excavation. This bid item includes material and placement of flowable fill under existing and proposed pavement, and wherever else specified on the plans or in the specifications. This item shall also include pipe anchors on polyethylene pipe runs as shown on the plans or required by the specifications to prevent the creep or contraction of the pipe. Measurement of quantities under this item shall be through fittings, encasements, and directional bores (only when a separate carrier pipe is specified within the directional bore pipe). No separate payment will be made under pipe items when the directional bore pipe is the carrier pipe. Measurements shall be further defined to be to the center of tie-in where new pipe contacts existing pipe at the center of connecting fittings, to the outside face of vault or structure walls, or to the point of main termination at dead ends. Please refer to the Utility Company's Specifications. If the Company does not have specifications, KYTC's Specifications shall be referenced. This item shall be paid LINEAR FEET (LF).

S FORCE MAIN AIR RLS/VAC VLV This bid item description shall apply to all force main air release/vacuum valve installations of every size except those defined as "Special". This item shall include the air release/vacuum valve, main to valve connecting line or piping, manhole/vault/structure, access casting or doors, tapping the main, labor, equipment, excavation, proper backfill and restoration required to install the air release/vacuum valve at the location shown on the plans or as directed in accordance with the specifications and standard drawings complete and ready for use. All air release/vacuum valves on a project shall be paid under one bid item regardless of size. No separate pay items will be established for size variations. Only in the case of the uniqueness of a particular air release/vacuum valve would a separate bid item be established. Please refer to the Utility Company's Specifications. If the Company does not have specifications, KYTC's Specifications shall be referenced. This item shall be paid EACH (EA) when complete.

S FORCE MAIN DIRECTIONAL BORE Payment under this item is made whenever the plans or specifications specifically show directional boring is to be utilized in order to minimize the impact of open cut for the installation of sewer or force main under streets, buildings, creeks, and etc. Payment under this item shall include the specified bore pipe, labor, and equipment. No separate payment shall be made for bore pipe installed in the bore whether used as a carrier pipe or an encasement of a separate carrier pipe. This item shall also include pipe anchors at each end of the bore when specified to prevent the creep or contraction of the bore pipe. Carrier pipe installed within a bore pipe shall be paid separately under pipe items. Payment under this item shall not be size specific and no separate bid items will be established for size variations. The bore pipe sizes to be included under this item shall be as shown on the plans and/or in the specifications. Any and all directional bores in each contract shall be paid under one directional bore bid item included in the contract regardless of size. Please refer to the Utility Company's Specifications. If the Company does not have specifications, KYTC's Specifications shall be referenced. This item shall be paid LINEAR FEET (LF).

S FORCE MAIN POINT RELOCATE This item is intended for payment for horizontal and/or vertical relocation of a short length of an existing main at the locations shown on the plans. This bid item is to be used to relocate an existing force main at point locations such as to clear a conflict at a

proposed drainage structure, pipe or any other similar short relocation situation, and where the existing pipe material is to be reused. The contractor shall provide any additional pipe or fitting material needed to complete the work as shown on the plans and specifications. The materials provided shall be of the same type and specification as those that exist. Substitution of alternative materials shall be approved by the engineer in advance on a case by case basis. New polyethylene wrap is to be provided (if wrap exists or is specified in the specifications to be used). If it is necessary that the pipe be disassembled for relay, payment under this item shall also include replacement of joint gaskets as needed. Bedding and backfill shall be provided and performed the same as with any other pipe installation as detailed in the plans and specifications. Payment under this item shall be for each location requiring an existing main to be relocated horizontally or vertically regardless of pipe size or relocation length. No separate pay items will be established for pipe size variations or relocation segment length variations. Force Main Relocate shall not be paid on a linear feet basis; but shall be shall be paid EACH (EA) at each location when complete and placed in service. Please refer to the Utility Company's Specifications. If the Company does not have specifications, KYTC's Specifications shall be referenced.

S FORCE MAIN TAP SLEVE/VALVE RANGE 1 OR 2 This item shall include the specified tapping sleeve, valve, valve box, concrete pad around valve box (when required in specifications or plans), labor, and equipment to install the specified tapping sleeve and valve, complete and ready for use in accordance with the plans and specifications. The size shall be the measured internal diameter of the live pipe to be tapped. The size tapping sleeve and valve to be paid under sizes 1 or 2 shall be as follows:

- Range 1 = All live tapped main sizes up to and including 8 inches
- Range 2 = All live tapped main sizes greater than 8 inches

Please refer to the Utility Company's Specifications. If the Company does not have specifications, KYTC's Specifications shall be referenced. This item shall be paid EACH (EA) when complete.

S FORCE MAIN TIE-IN This bid description shall be used for all force main tie-in bid items of every size except those defined as "Special". This item includes all labor, equipment, excavation, fittings, sleeves, reducers, couplings, blocking, anchoring, restoration, testing and backfill required to make the force main tie-in as shown on the plans and in accordance with the specifications complete and ready for use. This bid item shall include purge and sanitary disposal of any sewage from any abandoned segments of force main. Pipe for tie-ins shall be paid under separate bid items. Please refer to the Utility Company's Specifications. If the Company does not have specifications, KYTC's Specifications shall be referenced. This item shall be paid EACH (EA) when complete.

S FORCE MAIN VALVE This description shall apply to all force main valves of every size required in the plans and specifications, except those bid items defined as "Special". Payment under this description is to be for gate or butterfly force main valves being installed with new force main. This item includes the valve as specified in the plans and specifications, polyethylene wrap (if required by specification), labor, equipment, excavation, anchoring (if any), valve box and valve stem extensions, backfill, concrete pad around valve box (if required by specification), restoration, testing, and etc., required to install the specified valve at the location shown on the plans in accordance with the specifications and standard drawings complete and ready for use. If required on plans and/or proposed adjoining DIP is restrained, force main valves shall be restrained. Force main valve restraint shall be considered incidental to the force main valve and adjoining pipe. Please refer to the Utility Company's Specifications. If the Company does not have specifications, KYTC's Specifications shall be

referenced. This item shall be paid EACH (EA) when complete.

S FORCE MAIN VALVE BOX ADJUST Includes all labor, equipment, valve box and valve stem extensions (if required), excavation, backfill, concrete pad around valve box (when specified in specifications or plans), restoration, and etc., to adjust the top of the force main valve box to finished grade complete and ready for use. Please refer to the Utility Company's Specifications. If the Company does not have specifications, KYTC's Specifications shall be referenced. This item shall be paid EACH (EA) when complete.

S LATERAL CLEANOUT This item shall be for payment for installation of a cleanout in a service lateral line. This item shall include furnishing and installation of a tee, vertical pipe of whatever length required, and threaded cap. The cleanout shall extend from the lateral to final grade elevation. The size of the cleanout shall be equivalent to the size of the lateral. The cleanout materials shall meet the same specification as those for the lateral. The cleanout shall be installed at the locations shown on the plans or as directed by the engineer. Only one pay item shall be established for cleanout installation. No separate pay items shall be established for size or height variances. Please refer to the Utility Company's Specifications. If the Company does not have specifications, KYTC's Specifications shall be referenced. This item shall be paid EACH (EA) when complete.

S LATERAL LOCATE This bid item is to pay for all labor, equipment, and materials needed in locating an existing sanitary sewer service lateral for tie-in of the lateral to new mainline sewers and/or for the relocation of a lateral. This bid item shall be inclusive of any and all methods and efforts required to locate the lateral for tie-in or relocation of the lateral. Locating methods to be included under this items shall include, but are not limited to, those efforts employing the use of video cameras from within an existing sanitary sewer main or lateral, electronic locating beacons and/or tracers inserted into the sanitary sewer main or lateral, careful excavation as a separate operation from mainline sewer or lateral excavation, the use of dyes to trace the flow of a lateral, or any combination of methods required to accurately locate the lateral. Please refer to the Utility Company's Specifications. If the Company does not have specifications, KYTC's Specifications shall be referenced. This item shall be paid EACH (EA).

S LATERAL LONG SIDE This bid item description shall apply to all service lateral installations of every size up to and including 6 inch internal diameter, except those lateral bid items defined as "Special". This item includes the specified piping material, main tap, bends, clean outs, labor, equipment, excavation, backfill, testing, and restoration, at the locations shown on the plans or as directed, in accordance with the specifications and standard drawings, complete and ready for use. This bid item is to pay for service lateral installations where the ends of the lateral connection are on opposite sides of the public roadway. The new lateral must cross the centerline of the public roadway to qualify for payment as a long side lateral. The length of the service lateral is not to be specified. Payment under this item shall not be restricted by a minimum or maximum length. The contractor shall draw his own conclusions as to the length of piping that may be needed. Payment under this item shall include boring, jacking, or excavating across the public roadway for placement. Placement of a service lateral across a private residential or commercial entrance alone shall not be reason to make payment under this item. Private or commercial entrances shall not be considered a public roadway in defining payment under this item. No additional payment will be made for rock excavation or for bedding required in rock excavation. Please refer to the Utility Company's Specifications. If the Company does not have specifications, KYTC's Specifications shall be referenced. This item shall be paid EACH (EA) when complete.

S LATERAL SHORT SIDE This bid item description shall apply to all service lateral installations of every size up to and including 6 inch, except those lateral bid items defined as “Special”. This item includes the specified piping material, main tap tee, bends, clean outs, labor, equipment, excavation, backfill, testing, and restoration, at the locations shown on the plans or as directed, in accordance with the specifications and standard drawings, complete and ready for use. This bid item is to pay for lateral installations where both ends of the lateral connection are on the same side of the public roadway, or when an existing lateral crossing a public roadway will remain and is being extended, reconnected, or relocated with all work on one side of the public roadway centerline as shown on the plans. The length of the service lateral is not to be specified and shall not be restricted to any minimum or maximum length. Payment shall be made under this item even if the lateral crosses a private residential or commercial entrance; but, not a public roadway. Private or commercial entrances shall not be considered a public roadway in defining payment under this item. The contractor shall draw his own conclusions as to the length of piping that may be needed. No additional payment will be made for rock excavation or for bedding required in rock excavation. Please refer to the Utility Company’s Specifications. If the Company does not have specifications, KYTC’s Specifications shall be referenced. This item shall be paid EACH (EA) when complete.

S LINE MARKER This item is for payment for furnishing and installing a sewer utility line marker as specified by the utility owner specifications and plans. A line marker may consist of a post or monument of whatever materials specified and shall include markings and/or signage on same as specified by plans or specifications. This item shall include all labor, equipment, and materials needed for complete installation of the marker. This item shall be paid EACH (EA) when complete.

S MANHOLE Payment under this item is for the installation of new 4 foot interior diameter sanitary sewer manhole. Payment for manholes will be made at the contract unit price each in place complete and ready for use at the locations shown on plans in accordance with specifications and standard drawings. Manholes shall include concrete base, barrel sections, cone section or slab top, steps, excavation, backfilling, air testing, restoration, and cleanup in accordance with the specifications and standard drawings. Payment shall be made under this item regardless of whether the base is to be precast or cast-in-place (doghouse). All materials, except casting, shall be new and unused. An existing casting from an existing abandoned or removed manhole is to be reused and shall be considered incidental to this item. When a new casting is specified, or an existing casting is unavailable, it shall be paid as a separate bid item. Anchoring of casting, new or used, shall be considered incidental to this bid item. No additional compensation will be paid for manhole height variations. No additional payment will be made for rock excavation. Please refer to the Utility Company’s Specifications. If the Company does not have specifications, KYTC’s Specifications shall be referenced. This item shall be paid EACH (EA) when complete.

S MANHOLE ABANDON/REMOVE Payment under this item is for the partial removal and/or filling of any sanitary sewer manhole regardless of size or depth that no longer serves any purpose. Payment shall be made regardless of whether the manhole is or is not in conflict with other work. Any manhole requiring partial removal, but not total removal, in order to clear a conflict with other work shall be paid under this item. All manholes partially removed shall be removed to a point at least one foot below final grade, one foot below roadway subgrade, or one foot clear of any other underground infrastructure, whichever is lowest. If partial removal of an abandoned manhole is elected by the contractor, the remaining manhole structure shall be refilled with flowable fill. Payment for disposal of a sanitary sewer manhole will be made under this item only. Please refer to the Utility Company’s

Specifications. If the Company does not have specifications, KYTC's Specifications shall be referenced. This item shall be paid EACH (EA) when complete.

S MANHOLE ADJUST TO GRADE Payment under this item is for the adjustment of sanitary sewer casting elevation on all sizes of existing sanitary manholes. This work shall be performed in accordance with the sanitary sewer specifications. Payment shall be made under this bid item regardless of the amount of adjustment necessary to a sanitary sewer manhole casting or diameter of the manhole. Work under this pay item may be as simple as placing a bed of mortar under a casting; but, shall also be inclusive of installation of adjusting rings, and /or addition, removal, or replacement of barrel sections. The existing casting is to be reused unless a new casting is specified on the plans. New casting, when specified, shall be paid as a separate bid item. Anchoring of the casting shall be incidental to this item. Please refer to the Utility Company's Specifications. If the Company does not have specifications, KYTC's Specifications shall be referenced. This item shall be paid EACH (EA) when complete.

S MANHOLE CASTING STANDARD Payment under this bid items is for furnishing of a new standard traffic baring casting for sanitary manholes meeting the requirements of the sanitary sewer specifications and standard drawings. Please refer to the Utility Company's Specifications. If the Company does not have specifications, KYTC's Specifications shall be referenced. This item shall be paid EACH (EA) when installed.

S MANHOLE CASTING WATERTIGHT Payment under this bid item is for furnishing of a new watertight traffic baring casting for sanitary manholes meeting the requirements of the sanitary sewer specifications and standard drawings. Please refer to the Utility Company's Specifications. If the Company does not have specifications, KYTC's Specifications shall be referenced. This item shall be paid EACH (EA) when installed.

S MANHOLE RECONSTRUCT INVERT This bid item is to pay for all labor, equipment, and material for rework of the manhole bench to redirect or eliminate flow, such as when the flow of a pipe or pipes are being removed or redirected. This work will be as specified in the plans, specifications, or directed by the engineer. This work may consist of, but is not limited to, removal of concrete and/or placement of concrete in elimination or redirect of flow. This item shall also include providing and placement of a rubber seal or boot as required by utility specification, standard drawing or plan. The contractor shall draw his own conclusions as to the effort and scope of work needed to comply with the specifications, standard drawings, and plans. No payment shall be made under this bid when MANHOLE TAP EXISTING, or MANHOLE TAP EXISTING ADD DROP are being paid at the same location, as this type of work is included in those items. Please refer to the Utility Company's Specifications. If the Company does not have specifications, KYTC's Specifications shall be referenced. This item shall be paid EACH (EA) when complete.

S MANHOLE TAP EXISTING This bid item is to pay for all labor, equipment, and material for coring one opening in an existing manhole base, addition of a rubber seal as specified, and rework of the manhole bench to direct the additional pipe flow. The bid item shall be paid for each core opening added to a single manhole. This bid item shall also include any rework of the existing manhole bench due to the elimination of other existing pipes and flow. This work will be as specified in the plans, specifications, or directed by the engineer. This work may consist of, but is not limited to, removal of concrete and/or placement of concrete in the addition, elimination, or redirect of flow. The contractor shall draw his own conclusions as to the effort and scope of work needed to comply with the

specifications, standard drawings, and plans. Please refer to the Utility Company's Specifications. If the Company does not have specifications, KYTC's Specifications shall be referenced. This item shall be paid EACH (EA) when complete.

S MANHOLE TAP EXISTING ADD DROP This bid item is to pay for all labor, equipment, and material for coring one opening in an existing manhole base, addition of a rubber seal as specified, addition of a vertical drop pipe to the outside of the manhole, placement of reinforcing steel and concrete to encase vertical pipe, and rework of the manhole bench to direct the additional pipe flow. The bid item shall be paid for each drop added to a single manhole. This bid item shall also include any rework of the existing manhole bench due to the elimination of other existing pipes and flow. This work will be as specified in the plans, specifications, or directed by the engineer. This work may consist of, but is not limited to, removal of concrete and/or placement of concrete in the addition, elimination, or redirect of flow. The contractor shall draw his own conclusions as to the effort and scope of work needed to comply with the specifications, standard drawings, and plans. Please refer to the Utility Company's Specifications. If the Company does not have specifications, KYTC's Specifications shall be referenced. This item shall be paid EACH (EA) when complete.

S MANHOLE WITH DROP Payment under this item is for the installation of new 4 foot interior diameter sanitary sewer manhole with drop. Payment for drop manholes will be made at the contract unit price each in place complete and ready for use at the locations shown on plans in accordance with specifications and standard drawings. Drop manholes shall include concrete base, barrel sections, drop materials, cone section or slab top, steps, excavation, backfilling, air testing, restoration, and cleanup. Payment shall be made under this item regardless of whether the base is to be precast or cast-in-place (doghouse). All materials, except casting, shall be new and unused. An existing casting from an existing abandoned or removed manhole is to be reused and shall be considered incidental to this item. When a new casting is specified, or an existing casting is unavailable, it shall be paid as a separate bid item. Anchoring of casting, new or used, shall be considered incidental to this bid item. No additional compensation will be paid for manhole height variations. No additional payment will be made for rock excavation. Please refer to the Utility Company's Specifications. If the Company does not have specifications, KYTC's Specifications shall be referenced. This item shall be paid EACH (EA) when complete.

S MANHOLE WITH LINING Payment under this item is for the installation of new 4 foot interior diameter sanitary sewer manhole with corrosion resistant lining. Payment for manholes will be made at the contract unit price each in place complete and ready for use at the locations shown on plans in accordance with specifications and standard drawings. Manholes shall include concrete base, barrel sections, cone section or slab top, steps, lining, excavation, backfilling, air testing, restoration, and cleanup in accordance with the standard drawings. Payment shall be made under this item regardless of whether the base is to be precast or cast-in-place (doghouse). All materials, except casting, shall be new and unused. An existing casting from an existing abandoned or removed manhole is to be reused and shall be considered incidental to this item. When a new casting is specified, or an existing casting is unavailable, it shall be paid as a separate bid item. Anchoring of casting, new or used, shall be considered incidental to this bid item. No additional compensation will be paid for manhole height variations. No additional payment will be made for rock excavation. Please refer to the Utility Company's Specifications. If the Company does not have specifications, KYTC's Specifications shall be referenced. This item shall be paid EACH (EA) when complete.

S MANHOLE WITH TRAP Payment under this item is for the installation of a new manhole with

trap. Payment for trap manholes will be made at the contract unit price each in place complete and ready for use at the locations shown on plans in accordance with specifications and standard drawings. Trap manholes shall include concrete base, manhole structure and trap materials, cone section or slab top, steps, excavation, backfilling, air testing, restoration, and cleanup. All materials, except casting, shall be new and unused. Payment shall be made under this item regardless of whether the base is to be precast or cast-in-place (doghouse). An existing casting from an existing abandoned or removed manhole is to be reused and shall be considered incidental to this item. When a new casting is specified, or an existing casting is unavailable, it shall be paid as a separate bid item. Anchoring of casting, new or used, shall be considered incidental to this bid item. No additional compensation will be paid for manhole height variations. No additional payment will be made for rock excavation. Please refer to the Utility Company's Specifications. If the Company does not have specifications, KYTC's Specifications shall be referenced. This item shall be paid EACH (EA) when complete.

S PIPE This description shall apply to all PVC and ductile iron gravity sewer pipe bid items of every size and type 8 inches internal diameter and larger, except those bid items defined as "Special". This item includes the pipe specified by the plans and specifications, all fittings (including, but not limited to, tap tees and couplings for joining to existing similar or dissimilar pipes), polyethylene wrap (if required by specification), labor, equipment, excavation, bedding, restoration, pressure or vacuum testing, temporary testing materials, video inspection, backfill, and etc., required to install the specified new pipe and new fittings at the locations shown on the plans, or as directed, in accordance with the specifications and standard drawings complete and ready for use. This bid item shall include material and placement of flowable fill under existing and proposed pavement, and wherever specified on the plans or in the specifications. No additional payment will be made for rock excavation. Measurement of quantities under this item shall be through fittings and encasements to a point at the outside face of manhole barrels, or to the point of main termination at dead ends or lamp holes. Carrier pipe placed within an encasement shall be paid under this item and shall include casing spacers and end seals. Please refer to the Utility Company's Specifications. If the Company does not have specifications, KYTC's Specifications shall be referenced. This item shall be paid LINEAR FEET (LF).

S PIPE POINT REPAIR This item is to be used to pay for repair of short lengths of existing sanitary sewer pipe that, through prior video inspection or other means, are known to have pre-existing failure. Pipe Point Repair may be needed in preparation for installation of cured-in-place-pipe (CIPP) lining or other instances where failure is known and repair is prudent. The size of pipe shall not be defined in separate bid items. All diameter sizes of point repair shall be paid under this one item. The materials to be used to make the repair shall be as defined on the plans or in the specifications. This bid item shall include all excavation, pipe materials, joining materials to connect old and new pipe, bedding, and backfill to complete the repair at the locations shown on the plans or as directed by the engineer, complete and ready for use. This bid item shall include bypass pumping when required. Measurement shall be from contact point to contact point of old and new pipe. Please refer to the Utility Company's Specifications. If the Company does not have specifications, KYTC's Specifications shall be referenced. This item shall be paid LINEAR FEET (LF).

S PUMP STATION This item is for payment for installation of sanitary pump stations including above or below ground structure for housing of the pumps. This item shall include all pumps, piping, fittings, valves, electrical components, building materials, concrete, any other appurtenances, labor, equipment, excavation, and backfill, to complete the pump station installation as required by the plans, standard drawings, and specifications, complete and ready for use. Please refer to the Utility Company's Specifications. If the Company does not have specifications, KYTC's Specifications shall

be referenced. This item shall be paid LUMP SUM (LS) for each when complete.

S STRUCTURE ABANDON This item is to be used to pay for abandonment of larger above or below ground sewer structures such as air release/vacuum valve vaults, pump stations, tanks, etc. Payment under this time shall not be limited to size or scope; however structures with connecting pipes of 2 inches or less shall not be paid under this item; but, shall be considered incidental to sewer construction, (i.e., abandonment of standard air release/vacuum valves up to and including 2 inches would not be paid under this item). Payment under this item shall include all labor, equipment, and compacted fill or flowable fill for abandonment of the structure in place and restoration complete. No separate bid items will be established for size or structure variations. Please refer to the Utility Company's Specifications. If the Company does not have specifications, KYTC's Specifications shall be referenced. This item shall be paid EACH (EA) when complete.

S STRUCTURE REMOVAL This item is to be used to pay for removal of larger above or below ground sewer structures such as air release/vacuum valve vaults, pump stations, tanks, and etc. Payment under this time shall not be limited to size or scope; however, structures with connecting pipes of 2 inches or less shall not be paid under this item; but, shall be considered incidental to sewer construction, (i.e., removal of standard air release/vacuum valves and their structure up to and including 2 inches would not be paid under this item). Payment under this item shall include all labor, equipment, and compacted backfill for removal of the structure and restoration complete. No separate bid items will be established for size or structure variations. Please refer to the Utility Company's Specifications. If the Company does not have specifications, KYTC's Specifications shall be referenced. This item shall be paid EACH (EA) when complete.

Cardinal Drive KY 361
Item 4-7020
Sanitary Sewer Specifications

SANITARY SEWER INSTALLATION TECHNICAL SPECIFICATIONS

All pipe and accessories supplied for the City of Elizabethtown's sanitary sewer system shall be as specified herein. Where referenced specifications (ASTM, AWWA, etc.) are mentioned, these standards are deemed to be the minimum standard of quality of materials or methods for the installation of the materials.

All pipe and fittings installed for the sanitary sewer systems shall be Polyvinyl-Chloride (PVC). The pipe installed shall meet the following requirements. Other materials for specific applications must be approved by the City Engineer.

1. MATERIALS

PVC pipe 4 inch through 15 inch diameter shall be type PSM Polyvinyl Chloride (PVC) Sewer Pipe as specified per ASTM D 3034-81. The pipe shall be made of PVC plastic having a cell classification of 12454-B or 12454-C as defined in ASTM D 1784-81 and shall be homogeneous throughout, free of cracks, holes, foreign inclusions or other defects. The pipe shall be uniform in color, wall thickness, density and other physical properties. The maximum laying length for all PVC pipe supplied shall be 13.0± feet. Wall thickness shall be SDR-35 per ASTM D 3034-81 or wall thickness T-1 per ASTM F 679-80. Marking and identification of pipe shall be per ASTM D 3034-81 or ASTM F 679-80 as applicable.

PVC fittings supplied shall meet all physical and quality requirements as hereinbefore specified for PVC pipe. PVC fittings shall be those as manufactured by or supplied by the manufacturer of the pipe. PVC fittings for 4 inch through 15 inch diameter pipe shall meet the dimensional requirements of the tables as shown in ASTM D 3034-81 except that saddle-type wyes or tee branches shall not be allowed for use on new sewer mains.

Joints for PVC pipe and fittings for sanitary sewer lines shall be the "Push-On-Type" composed of elastomeric ring gaskets compressed in the annular space between a bell end or socket and spigot end of the pipe. All surfaces of the bell, socket or spigot end of the pipe against which the ring gasket may bear shall be smooth, free of cracks or other imperfections that could adversely affect the sealing capacity of the joint. Lubricant for use in assembling joint shall be supplied with the pipe or be of the specific manufacturer as recommended by the pipe manufacturer for use with the specified pipe supplied. The lubricant shall not cause deterioration of either the elastomeric ring gasket or pipe material. Where PVC pipe and fittings are connected to piping of other materials, the manufacturer's standard adapters or transition pieces shall be used.

Manholes shall be precast reinforced concrete risers and tops and shall meet the requirements of the Standard Drawings and ASTM C-478-80. All basic materials

Cardinal Drive KY 361
Item 4-7020
Sanitary Sewer Specifications

specified herein shall be tested and inspected by an approved commercial testing laboratory prior to delivery to the site, and all materials which fail to conform to these specifications shall be rejected. After delivery to the site, all materials that have been damaged in transit, or are otherwise unsuitable for use in the work, shall be rejected and removed from the site. The commercial testing laboratory shall be engaged and paid for by the Contractor. All joints in new manholes shall be constructed using 3/8" thick minimum flexible neoprene boots meeting the requirements of ASTM C443. The boot assembly shall include a properly formed boot of neoprene or equal and shall include internal and external bands of 304 stainless steel per ASTM A167, and an internal bank of anodized aluminum 6061-T6, T-651. Gasket type sealant to fill tongue and groove joints at top of precast manhole bases and between barrel sections shall be preformed, flexible, watertight, designed for specific joint requirements and meet Federal Specifications SS-S-00210 and AASHTO M-198.

Manhole frames and covers shall be made of cast iron construction to the minimum requirements of Federal Specification WW-1-652 or to Class 30, Serial Designation AO48 of the American Society for Testing Materials, for "Gray Iron Castings", unless otherwise directed by the City Engineer. All castings shall be made accurately to the required dimensions and shall be sound, smooth, clean, and free from blisters and other defects. Defective castings, which have been plugged or otherwise treated to remedy defects, shall be rejected. Contact surfaces of frames and covers shall be machined so that covers rest securely in the frame with no rocking and with covers in contact surfaces. All castings shall be thoroughly cleaned subsequent to machining and, before rusting begins, shall be painted with a bituminous coating so as to present a smooth finish, tough and tenacious when cold but not tacky with any tendency to scale. Each casting shall have its actual weight in pounds stenciled or painted thereon with white paint by the manufacturer, thereof.

Manhole castings shall be **prior approved by the City of Elizabethtown Engineering Department** and shall, typically, consist of 22 3/4 inch diameter cover, having a weight of 125 pounds or greater for the cover and 180 pounds or greater for the frame. Watertight manhole lids may be required in certain applications as indicated on the Standard Details.

Manhole ladder bars shall be hot dip galvanized in accordance with ASTM A-153, Class B or polypropylene plastic encapsulated steel as manufactured by M.A. Industries or approved equal.

Manhole Adjusting Rings shall be interlocking rings with level or sloped edge in thickness and diameter matching manhole frame and cover. Include sealant recommended by ring manufacturer.

Manhole Grade Rings shall be reinforced-concrete rings, 6 to 9 inch total thickness, to match diameter of manhole frame and cover.

Drop manholes shall be used where the difference in the invert elevation of two or more sewers intersecting in one manhole is 2 feet or more and shall be constructed in the manner shown on Standard Details. The drop manhole shall be similar in construction to the standard manhole except that a drop connection of pipe and fitting of the proper size and material shall be constructed outside the manhole and supported by 3000 psi concrete as indicated on the Standard Details.

Manhole inverts shall be constructed of 3000 psi concrete to the approximate cross section of the sewer connected thereto. Necessary changes in cross section shall be made gradually from side to side of the manhole. Changes in direction of flow of the sewers shall be made to a true curve of as large a radius as is permitted by the size of the manhole.

3. INSTALLATION

Proper procedures shall be used during the **installation** of the sanitary sewer pipes. The Engineering Department shall be contacted prior to the installation of any new sanitary sewer system. The installation shall be as follows:

- a) Before sewer pipe is placed in position in the trench, the bottom and sides of the trench shall be carefully prepared and any necessary bracing and sheeting installed as provided in these specifications.
- b) Water shall not be allowed to run or stand in the trench while pipe is being laid, before the joint has completely set, or before the trench has been backfilled. The Contractor shall not open at any time more trench than his available pumping facilities are able to dewater.
- c) Trench bottoms shall be brought to exact line and grade with compacted crushed stone (K.D.O.T. #9 or other stone as approved) as directed by the Engineer.
- d) Each piece of pipe and special fitting shall be carefully inspected before it is placed, and no defective pipe shall be laid in the trench. Pipe laying shall proceed up grade starting at the lower end of the grade and with the bells up grade.
- e) Wyes and tee branches shall be installed in the sanitary sewer lines to properly serve each lot facing or abutting on the street or alley in which the sewer is being laid, and at such other locations as may be designated by the Engineer. Such branches shall be closed with plugs adequately braced to withstand test pressure. All tees and wyes shall be adequately marked so that they may easily be found prior to future excavation.
- f) The interior of the pipe in place shall be thoroughly inspected and cleaned prior to installation. Prior to testing, all piping shall be inspected, and all earth, trash, rags, and other foreign matter removed from the interior.

Cardinal Drive KY 361
Item 4-7020
Sanitary Sewer Specifications

- g) Backfilling around the pipe shall be accomplished using compacted crushed stone (K.D.O.T. #9 or other stone as approved) to a depth of 12" above the top of the pipe. The rest of the trench shall be backfilled using native trench materials. Trenches for all pipes under pavement shall be provided with full depth compacted stone backfill.
- h) Where sewers mains cross water mains and have less than 18 inches of separation, the sewer pipe for ten feet (10') each side of the crossing shall have a watertight carrier pipe or full pipe concrete encasement.
- i) Sewer service connections shall be marked with a 2" PVC pipe from the top of the service connection cap to two feet above finished grade. PVC pipe above grade shall be painted green.
- j) Sewer pipes, which when completed have less than 30 inches of cover, shall be provided with concrete protection as required by the Ten State Standards.
- k) Set tops of frames and covers flush with finished surfaces that occur in pavements.

The following procedures shall be used when **connecting to existing sanitary sewer** systems. Connections shall be made by removing a section of the sewer from the existing line and inserting in the space, a wye branch of proper size, or by construction of a manhole. If a sewer is 8 inches or larger, the connection to an existing sewer pipe shall be made with a standard "doghouse" style manhole. Connections to existing manholes, or inlets, shall be made by core drilling a hole in the wall of existing structure and installing a kor-n-seal boot into the hole in accordance with manufacturer's recommendation. The bottom of all existing manholes shall be shaped or reshaped as necessary to fit the invert of the new and existing sewer pipes.

4. TESTING SANITARY SEWER AND MANHOLES

All sanitary sewer pipes and manholes shall be tested in the presence of the City of Elizabethtown Engineering Department. Manholes shall be tested in accordance with ASTM C 1244-93 – Standard Test Method for Concrete Sewer Manholes by the Negative Air Pressure (Vacuum) Test. PVC sewer pipes shall be tested in accordance with ASTM F 1417-92 0 Standard Test Method for Installation Acceptance of Plastic Gravity Sewer Lines Using Low-Pressure Air. The Contractor will furnish all equipment and facilities and all personnel for conducting the tests.

An **air test** and a deflection test will be made after all service tee wyes have been installed and backfilling has been completed and compacted. The backfilling must be completed for a minimum of thirty (30) days prior to the deflection test being conducted. All taps and end of sewer services shall be plugged with flexible joint plugs or caps securely fastened to withstand the internal test pressures. Such plugs or caps shall be

readily suitable for making a flexible jointed connections or extension. Prior to air testing, the pipe shall be checked to see that it is clean. If not, it shall be cleaned by passing through the pipe a full gauge squeegee. It shall be the Contractor's responsibility to have the pipe clean. Immediately following this check or cleaning, the pipe installation shall be tested with low-pressure air. If the pipe installation fails to meet these requirements, the Contractor shall determine, at their expense, the source or sources of leakage, and they shall repair or replace all defective materials or workmanship. The complete pipe installation shall meet the requirements of this test before being considered acceptable.

Plugs used to close the sewer pipe for the air test must be securely braced to prevent the unintentional release of a plug, which can become a high velocity projectile. Gages, air piping manifolds, and valves shall be located at the top of the ground. No one shall be permitted to enter a manhole where a plugged pipe is under pressure. Four pounds (gauge) air pressure develops a force against the plug in a 12-inch diameter pipe of approximately 450 pounds. A safety release device set to release at 10 pounds per square inch is to be provided between the air supply and the sewer under test. Regardless of outcome of any tests, any noticeable leak shall be repaired.

A **deflection test** shall be performed on all flexible pipes. The test shall be conducted after the final backfill has been in place at least 30 days. No pipe shall exceed a deflection of 5%. If the test is run using a rigid ball or mandrel, it shall have a diameter equal to 95% of the inside diameter of the pipe. The test shall be performed without mechanical pulling devices.

5. SAFELOADING/ABDONMENT OF SANITARY SEWER AND MANHOLES

Safeloading shall consist of completely filling the designated areas with grout in such a manner to make them safe from collapse or at the Contractor's option, safeloading may be done by filling the designated area with free-flowing concrete, grout or other approved free flowing material. Appreciable deposits of debris shall be removed from other structures prior to safeloading. The ends shall be plugged by use of bulkheads containing small openings at the tops through which the safeloading material may be pumped at a minimum pressure of 15 pounds per square inch.

Manhole structures to be abandoned in place shall be completed by removing structure frames, covers, grates, mechanically locking internal chimney seals and similar items. All pipes shall be bulkheaded. Walls shall be lowered to a minimum of 2 feet below final grade if in earth or to 12 inches below subgrade in pavement (if plan indicated). The remaining manhole volume shall be filled with safeloading material as previously specified to the satisfaction of the City of Elizabethtown's Public Works or project assigned field representative.

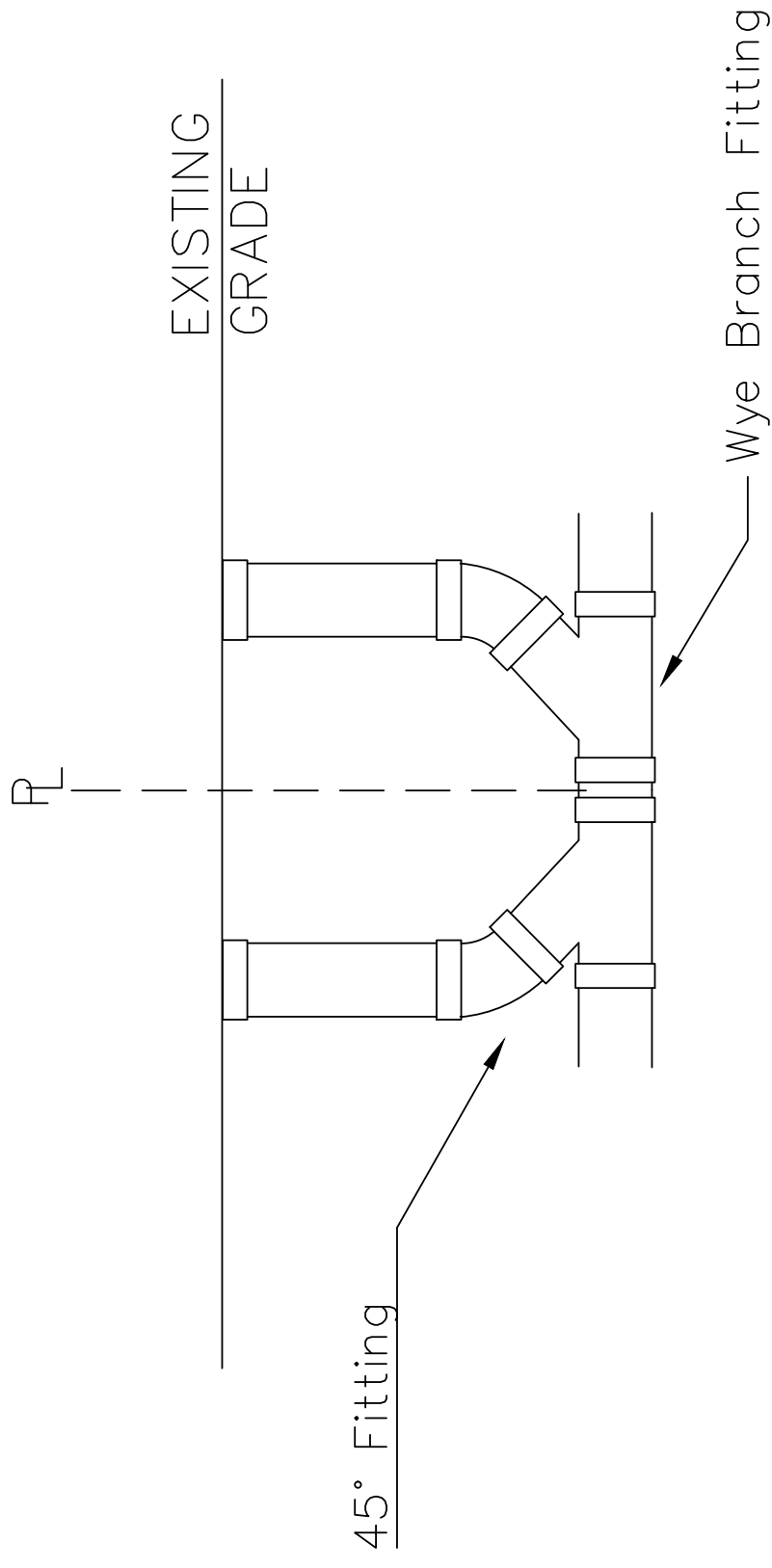

1. SHALL BE SCHEDULE 40 PVC
2. JOINTS GLUED OR GASKET
3. 6" MIN #9 CRUSHED STONE EMBEDMENT

TYPICAL CLEANOUT DETAIL
DRAWN BY: M. PAGE
DATE: 11/06/17



NOTE: STONE FOR BEDDING & BACKFILL, 6" THRU 16"
 PIPE SHALL BE #9 CRUSHED STONE UNLESS
 OTHERWISE DIRECTED BY THE ENGINEER

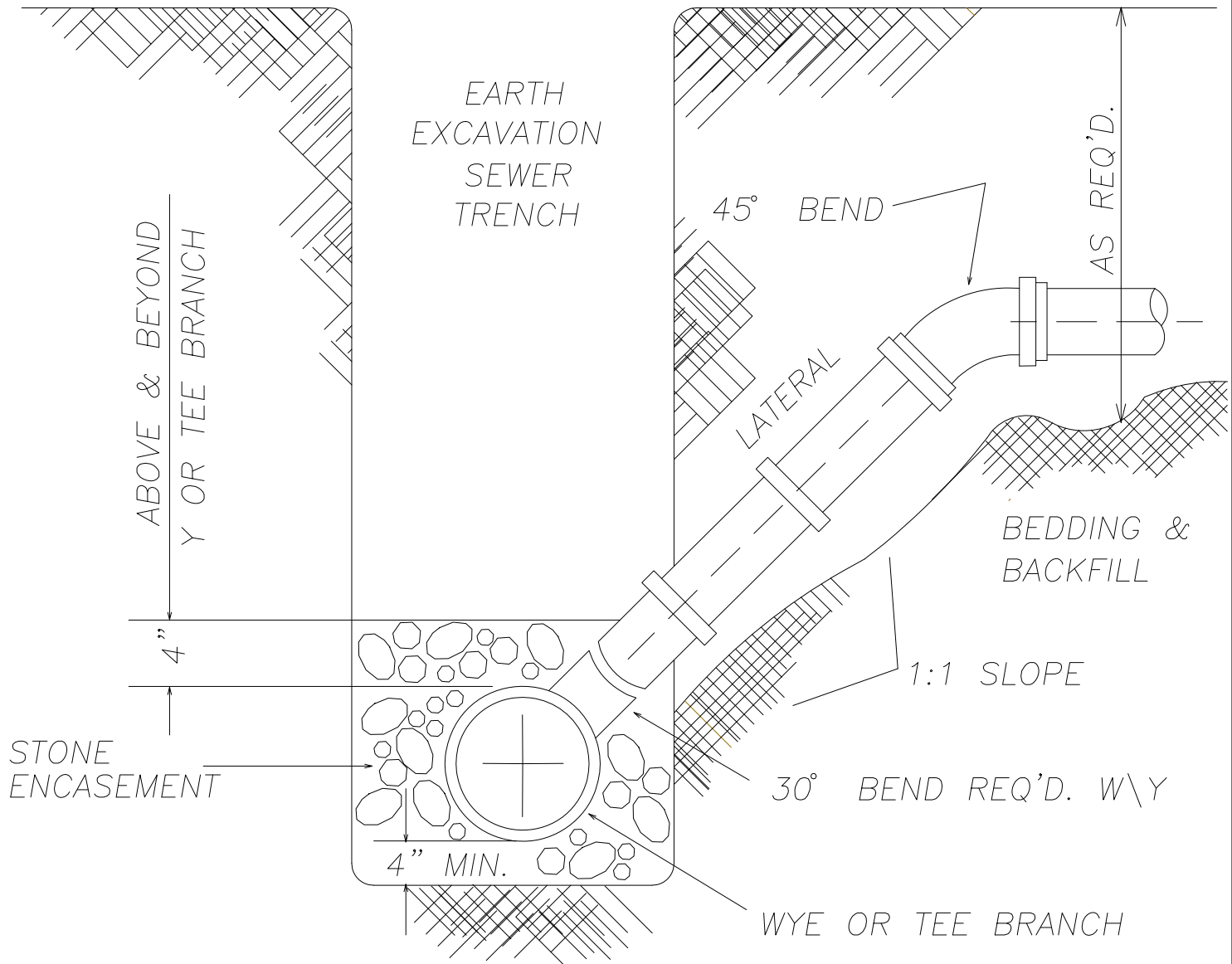

C:\p\scott\Desktop\details\sewer\DAT_TREN.dwg, Layout1, zizzz2006 1:34:54 PM, A0006 PDF

<small> Aerial photography and digital mapping prepared by Photo Science, Inc. of Lexington, KY. Aerial photography flown April 13, 2001. Horizontal control based on North American datum of 1983. Vertical control based on North American Vertical datum of 1988. The City of Elizabethtown accepts no liability for the accuracy of this </small>	Drawn: MSR	Date:
	Checked:	Rev.:
	Approved:	Rev.:
NO SCALE		

**TYPICAL DETAIL SEWER
 LATERALS IN DEEP TRENCHES
 ELIZABETHTOWN, KY**

City of
ELIZABETHTOWN
 Engineering Department

NOTE:

PLACE "TAR MASTIC" ON
 INSIDE LIP OF PRECAST
 BARRELL SECTION AND
 A WATERSTOP GASKET
 AROUND OUTSIDE OF PIPE
 WHERE IT PENETRATES
 THE MANHOLE.

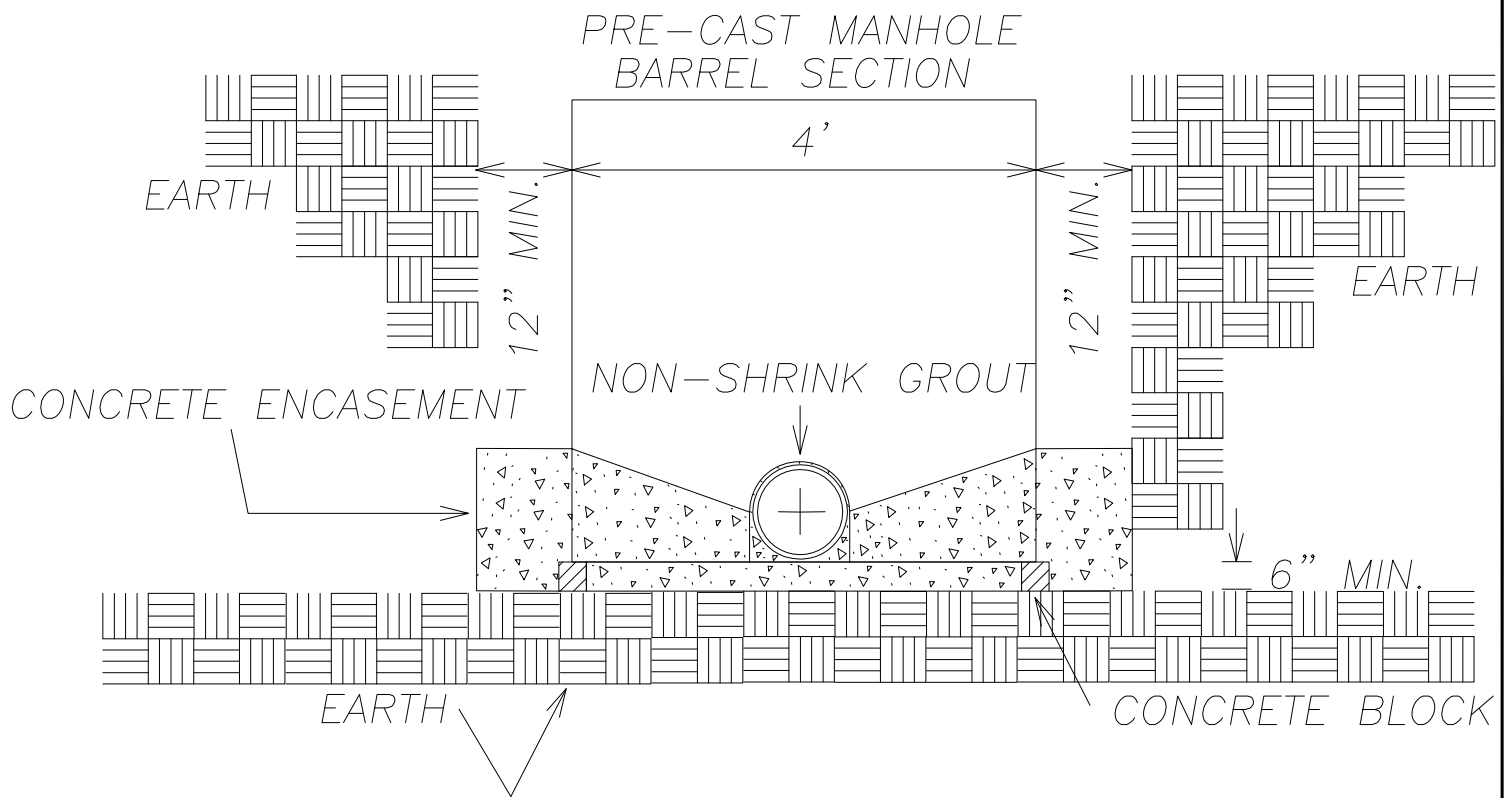

NOT TO SCALE

C:\scott\Desktop\details\sewer\MH_EX.LIN.dwg - Layout1 - 2/22/2008 1:52:20 PM - Adobe PDF

Aerial photography and
 digital mapping prepared
 by Photo Science, Inc.,
 Lexington, KY. Aerial
 photography flown April
 2001. Horizontal
 control based on North
 American datum of 1983.
 Vertical control based on
 North American Vertical
 datum of 1988. The
 City of Elizabethtown
 accepts no liability for
 the accuracy of this
 document.

Drawn: MSR	Date:
Checked:	Rev.:
Approved:	Rev.:
NO SCALE	

**TYPICAL DETAIL SEWER
 MANHOLE SET ON EXISTING
 LINE
 ELIZABETHTOWN, KY**

City of
ELIZABETHTOWN
 Engineering Department

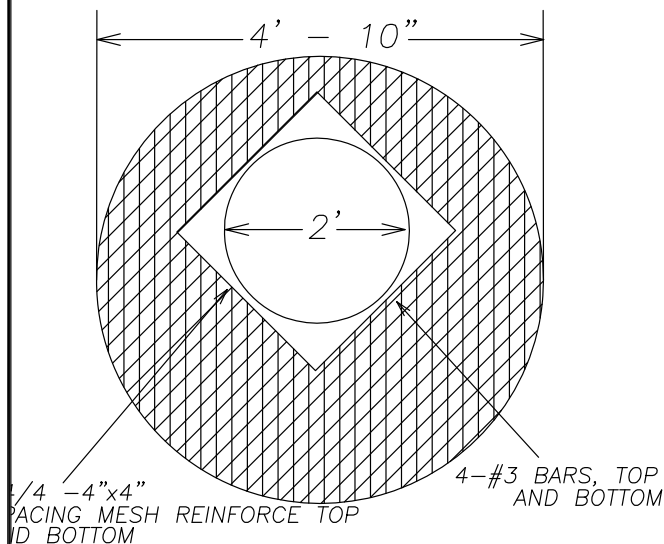

CONCRETE TOP SLAB
FOR SHALLOW MANHOLE

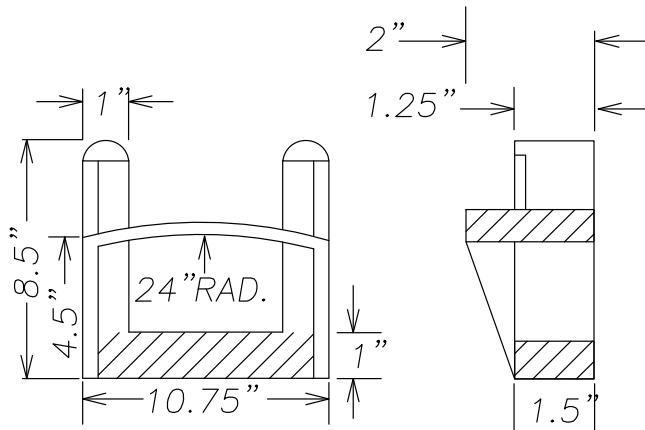

MANHOLE
STEPS

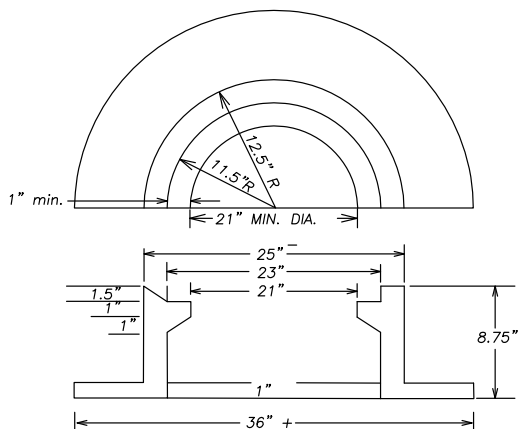

FRAME

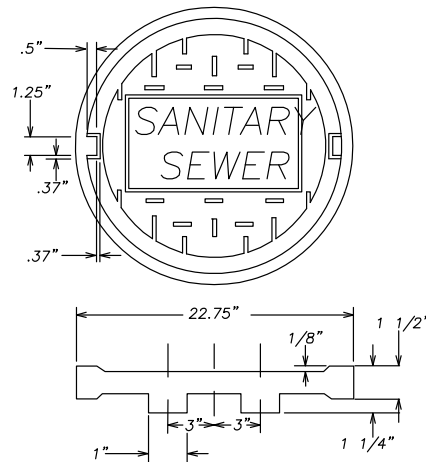

COVER

MANHOLE FRAME AND COVER— MIN. WT.— 325 LBS FOR
NON TRAFFIC OR 425 LBS FOR TRAFFIC

Aerial photography and digital mapping prepared by Photo Science, Inc. of Lexington, KY. Aerial photography flown March 27, 1991. Horizontal control based on North American datum of 1983. Vertical control based on National Geodetic datum of 1927. The City of Elizabethtown accepts no liability for the accuracy of this document.

Drawn: MSR	Date:
Checked:	Rev.:
Approved:	Rev.:
Scale: NONE	

TYPICAL MANHOLE FRAME
AND COVER DETAIL
ELIZABETHTOWN, KY



NO ROCK ALLOWED
 OUTSIDE PAVED AREAS

NOTE: SEE BACKFILL
 REQUIREMENTS
 BELOW

8" OF #9 STONE
 (6" THRU 15" PIPE)
 12" OF #9 STONE
 (18" PIPE AND UP)

4" MIN. BELOW
 BARREL & BELL

STONE BEDDING
 & BACKFILL-SHALL BE
 #9 CRUSHED STONE

BACKFILL REQUIREMENTS:

- 1) EARTH BACKFILL WITH NO ROCK
 COMPACTED TO 95% IN GRASS AREAS
- 2) FULL-DEPTH DENSE GRADE AGGREGATE (DGA)
 FULLY COMPACTED UNDER ALL PARKING LOTS
 AND DRIVING SURFACES (ASPHALT, CONCRETE, ETC)

Aerial photography and
 digital mapping prepared by
 Photo Science, Inc. of
 Lexington, KY. Aerial
 photography flown March
 13, 2007. Horizontal
 control based on North
 American datum of 1983.
 Vertical control based on
 North American Vertical
 datum of 1988. The City of
 Elizabethtown accepts no
 liability for the accuracy of
 this document.

Drawn: A. CRUSE Date: 3/16/95
 Checked: MSR Rev.: 7/30/10
 Approved: Rev.:

Scale: NONE

TYPICAL PIPE BEDDING ON
 EARTH



City of
ELIZABETHTOWN
 Engineering Department

NOT TO SCALE

SEE TECHNICAL SPECIFICATIONS

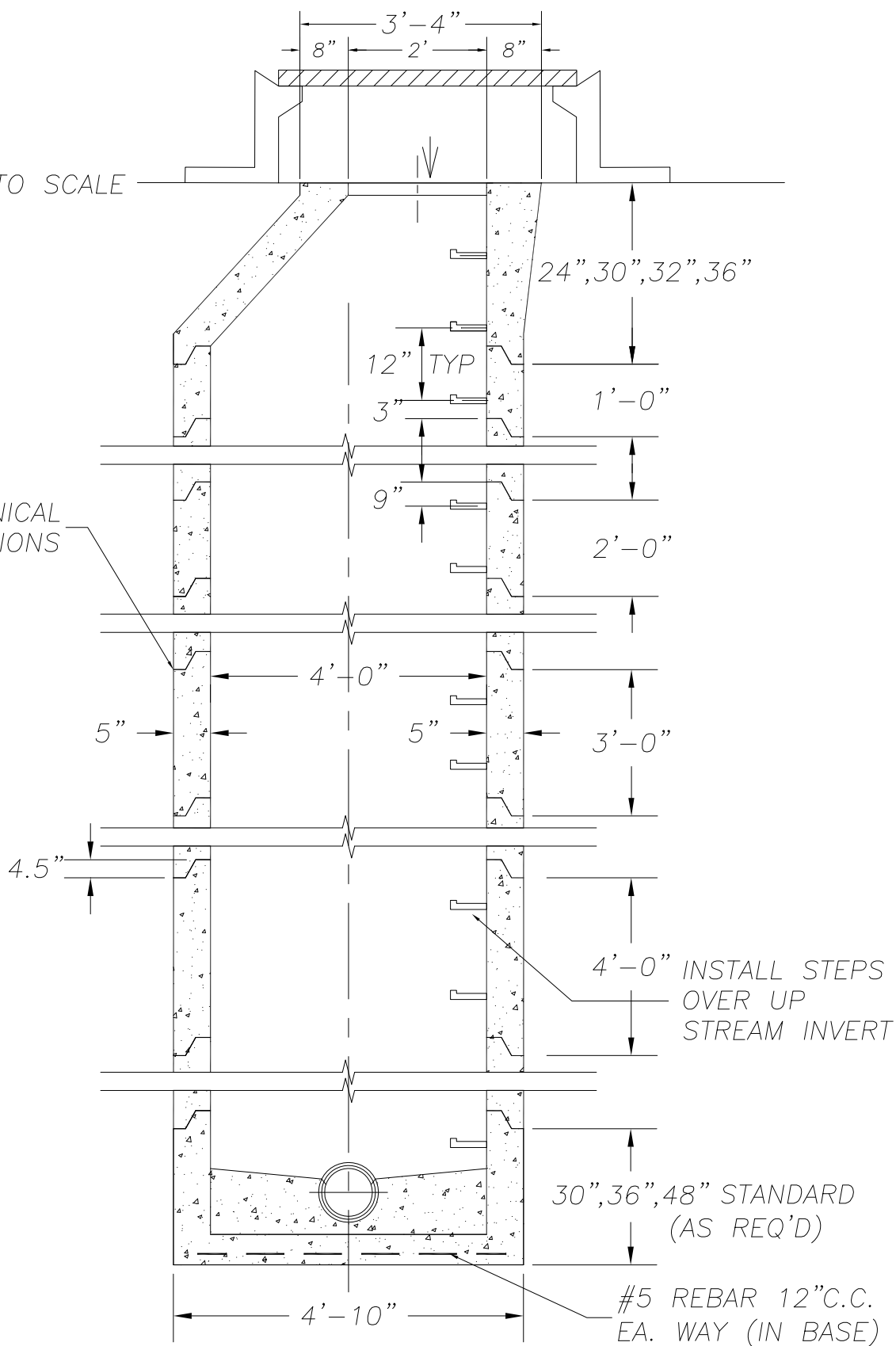

gs scott/Desktop/details/sewer/TYP_MH.dwg - Layout 1, 2/22/2008 1:50:06 PM, Adobe PDF

Aerial photography and digital mapping prepared by Photo Science, Inc., Lexington, KY. Aerial photography flown April 2001. Horizontal control based on North American datum of 1983. Vertical control based on North American Vertical datum of 1988. The City of Elizabethtown accepts no liability for the accuracy of this document.

Drawn: MSR	Date:
Checked:	Rev.:
Approved:	Rev.:
NO SCALE	

**TYPICAL MANHOLE
ELIZABETHTOWN, KY**

City of
ELIZABETHTOWN
Engineering Department

KyTC BMP Plan for Project CID ## - #####



Kentucky Transportation Cabinet

Highway District __ (1)

And

_____ (2), Construction

**Kentucky Pollutant Discharge Elimination System
Permit KYR10
Best Management Practices (BMP) plan**

Groundwater protection plan

For Highway Construction Activities

For

**Relocate Intersection of Woodland Drive at US
31W**

Project: CID ## - #####

KyTC BMP Plan for Project CID ## -

Project information

Note – (1) = Design (2) = Construction (3) = Contractor

1. Owner – Kentucky Transportation Cabinet, District __ (1)
2. Resident Engineer: (2)
3. Contractor name: (2)
Address: (2)

Phone number: (2)
Contact: (2)
Contractors agent responsible for compliance with the KPDES permit requirements (3):
4. Project Control Number (2)
5. Route (Address) (1)
Woodland Drive
Elizabethtown, KY
6. Latitude/Longitude (project mid-point) dd/mm/ss, dd/mm/ss (1)
37dd 42mm 35ss
-85dd 52 mm 56ss
7. County (project mid-point) (1)
Hardin
8. Project start date (date work will begin): (2)
9. Projected completion date: (2)

KyTC BMP Plan for Project CID ## - #####

A. Site description:

1. Nature of Construction Activity (from letting project description) (1)
Relocate Intersection of Woodland Drive at US 31W
2. Order of major soil disturbing activities (2) and (3)
3. Projected volume of material to be moved (1)
8700 CU YD
4. Estimate of total project area (acres) (1)
6.3 Acres
5. Estimate of area to be disturbed (acres) (1)
6.3 Acres
6. Post construction runoff coefficient will be included in the project drainage folder. Persons needing information pertaining to the runoff coefficient will contact the resident engineer to request this information(1)
7. Data describing existing soil condition (1) & (2)

Soil Group	Soil Symbol	Hydrologic Soil Group	Erosion Hazard
Bedford Silt Loam	Br	C/D	Moderate
Crider Silt Loam	Cr	B	Moderate
Nolin Silt Loam	No	B	Slight
Vertrees Silt Loam	Vr	C	Severe
Vertrees Silty Clay Loam	Vt	C	Severe

8. Data describing existing discharge water quality (if any) (1) & (2)
None
9. Receiving water name (1)
10. TMDLs and Pollutants of Concern in Receiving Waters: (1 DEA)
No TMDLs developed for either stream

KyTC BMP Plan for Project CID ## -

11. Site map – Project layout sheet plus the erosion control sheets in the project plans that depict Disturbed Drainage Areas (DDAs) and related information. These sheets depict the existing project conditions with areas delineated by DDA (drainage area bounded by watershed breaks and right of way limits), the storm water discharge locations (either as a point discharge or as overland flow) and the areas that drain to each discharge point. These plans define the limits of areas to be disturbed and the location of control measures. Controls will be either site specific as designated by the designer or will be annotated by the contractor and resident engineer before disturbance commences. The project layout sheet shows the surface waters and wetlands.

12. Potential sources of pollutants:

The primary source of pollutants is solids that are mobilized during storm events. Other sources of pollutants include oil/fuel/grease from servicing and operating construction equipment, concrete washout water, sanitary wastes and trash/debris. (3)

B. Sediment and Erosion Control Measures:

1. Plans for highway construction projects will include erosion control sheets that depict Disturbed Drainage Areas (DDAs) and related information. These plan sheets will show the existing project conditions with areas delineated by DDA within the right of way limits, the discharge points and the areas that drain to each discharge point. Project managers and designers will analyze the DDAs and identify Best Management Practices (BMPs) that are site specific. The balance of the BMPs for the project will be listed in the bid documents for selection and use by the contractor on the project with approval by the resident engineer.

Projects that do not have DDAs annotated on the erosion control sheets will employ the same concepts for development and managing BMP plans.

2. Following award of the contract, the contractor and resident engineer will annotate the erosion control sheets showing location and type of BMPs for each of the DDAs that will be disturbed at the outset of the project. This annotation will be accompanied by an order of work that reflects the order or sequence of major soil moving activities. The remaining DDAs are to be designated as “Do Not Disturb” until the contractor and resident engineer prepare the plan for BMPs to be employed. The initial BMP’s

KyTC BMP Plan for Project CID ## -

shall be for the first phase (generally Clearing and Grubbing) and shall be modified as needed as the project changes phases. The BMP Plan will be modified to reflect disturbance in additional DDA's as the work progresses. All DDA's will have adequate BMP's in place before being disturbed.

3. As DDAs are prepared for construction, the following will be addressed for the project as a whole or for each DDA as appropriate:

- Construction Access – This is the first land-disturbing activity. As soon as construction begins, bare areas will be stabilized with gravel and temporary mulch and/or vegetation.
- At the beginning of the project, all DDAs for the project will be inspected for areas that are a source of storm water pollutants. Areas that are a source of pollutants will receive appropriate cover or BMPs to arrest the introduction of pollutants into storm water. Areas that have not been opened by the contractor will be inspected periodically (once per month) to determine if there is a need to employ BMPs to keep pollutants from entering storm water.
- Clearing and Grubbing – The following BMP's will be considered and used where appropriate.
 - Leaving areas undisturbed when possible.
 - Silt basins to provide silt volume for large areas.
 - Silt Traps Type A for small areas.
 - Silt Traps Type C in front of existing and drop inlets which are to be saved
 - Diversion ditches to catch sheet runoff and carry it to basins or traps or to divert it around areas to be disturbed.
 - Brush and/or other barriers to slow and/or divert runoff.
 - Silt fences to catch sheet runoff on short slopes. For longer slopes, multiple rows of silt fence may be considered.
 - Temporary Mulch for areas which are not feasible for the fore mentioned types of protections.
 - Non-standard or innovative methods.
- Cut & Fill and placement of drainage structures - The BMP Plan will be modified to show additional BMP's such as:
 - Silt Traps Type B in ditches and/or drainways as they are completed
 - Silt Traps Type C in front of pipes after they are placed
 - Channel Lining
 - Erosion Control Blanket
 - Temporary mulch and/or seeding for areas where construction activities will be ceased for 21 days or more.
 - Non-standard or innovative methods

KyTC BMP Plan for Project CID ## -

- Profile and X-Section in place – The BMP Plan will be modified to show elimination of BMP's which had to be removed and the addition of new BMP's as the roadway was shaped. Probably changes include:
 - Silt Trap Type A, Brush and/or other barriers, Temporary Mulch, and any other BMP which had to be removed for final grading to take place.
 - Additional Silt Traps Type B and Type C to be placed as final drainage patterns are put in place.
 - Additional Channel Lining and/or Erosion Control Blanket.
 - Temporary Mulch for areas where Permanent Seeding and Protection cannot be done within 21 days.
 - Special BMP's such as Karst Policy
- Finish Work (Paving, Seeding, Protect, etc.) – A final BMP Plan will result from modifications during this phase of construction. Probably changes include:
 - Removal of Silt Traps Type B from ditches and drainways if they are protected with other BMP's which are sufficient to control erosion, i.e. Erosion Control Blanket or Permanent Seeding and Protection on moderate grades.
 - Permanent Seeding and Protection
 - Placing Sod
 - Planting trees and/or shrubs where they are included in the project
- BMP's including Storm Water Management Devices such as velocity dissipation devices and Karst policy BMP's to be installed during construction to control the pollutants in storm water discharges that will occur after construction has been completed are : (1)

C. Other Control Measures

1. No solid materials, including building materials, shall be discharged to waters of the commonwealth, except as authorized by a Section 404 permit.
2. Waste Materials

All waste materials that may leach pollutants (paint and paint containers, caulk tubes, oil/grease containers, liquids of any kind, soluble materials, etc.) will be collected and stored in appropriate covered waste containers. Waste containers shall be removed from the project site on a sufficiently frequent basis as to not allow wastes to become a source of pollution. All personnel will be instructed regarding the correct procedure for waste disposal. Wastes

KyTC BMP Plan for Project CID ## -

will be disposed in accordance with appropriate regulations. Notices stating these practices will be posted in the office.

3. Hazardous Waste

All hazardous waste materials will be managed and disposed of in the manner specified by local or state regulation. The contractor shall notify the Section Engineer if there any hazardous wastes being generated at the project site and how these wastes are being managed. Site personnel will be instructed with regard to proper storage and handling of hazardous wastes when required. The Transportation Cabinet will file for generator, registration when appropriate, with the Division of Waste Management and advise the contractor regarding waste management requirements.

4. Spill Prevention

The following material management practices will be used to reduce the risk of spills or other exposure of materials and substances to the weather and/or runoff.

➤ **Good Housekeeping:**

The following good housekeeping practices will be followed onsite during the construction project.

- An effort will be made to store only enough product required to do the job
- All materials stored onsite will be stored in a neat, orderly manner in their appropriate containers and, if possible, under a roof or other enclosure
- Products will be kept in their original containers with the original manufacturer's label
- Substances will not be mixed with one another unless recommended by the manufacturer
- Whenever possible, all of the product will be used up before disposing of the container
- Manufacturers' recommendations for proper use and disposal will be followed
- The site contractor will inspect daily to ensure proper use and disposal of materials onsite

➤ **Hazardous Products:**

These practices will be used to reduce the risks associated with any and all hazardous materials.

KyTC BMP Plan for Project CID ## -

- Products will be kept in original containers unless they are not resealable
- Original labels and material safety data sheets (MSDS) will be reviewed and retained
- Contractor will follow procedures recommended by the manufacturer when handling hazardous materials
- If surplus product must be disposed of, manufacturers' or state/local recommended methods for proper disposal will be followed

The following product-specific practices will be followed onsite:

➤ **Petroleum Products:**

Vehicles and equipment that are fueled and maintained on site will be monitored for leaks, and receive regular preventative maintenance to reduce the chance of leakage. Petroleum products onsite will be stored in tightly sealed containers, which are clearly labeled and will be protected from exposure to weather.

The contractor shall prepare an Oil Pollution Spill Prevention Control and Countermeasure plan when the project that involves the storage of petroleum products in 55 gallon or larger containers with a total combined storage capacity of 1,320 gallons. This is a requirement of 40 CFR 112.

This project (will / will not) (3) have over 1,320 gallons of petroleum products with a total capacity, sum of all containers 55 gallon capacity and larger.

➤ **Fertilizers:**

Fertilizers will be applied at rates prescribed by the contract, standard specifications or as directed by the resident engineer. Once applied, fertilizer will be covered with mulch or blankets or worked into the soil to limit exposure to storm water. Storage will be in a covered shed. The contents of any partially used bags of fertilizer will be transferred to a sealable plastic bin to avoid spills.

➤ **Paints:**

All containers will be tightly sealed and stored indoors or under roof when not being used. Excess paint or paint wash water will not be discharged to the drainage or storm sewer system but will be properly disposed of according to manufacturers' instructions or state and local regulations.

➤ **Concrete Truck Washout:**

Concrete truck mixers and chutes will not be washed on pavement, near storm drain inlets, or within 75 feet of any ditch, stream, wetland, lake, or sinkhole. Where possible, excess concrete and wash water will be discharged to areas

KyTC BMP Plan for Project CID ## -

prepared for pouring new concrete, flat areas to be paved that are away from ditches or drainage system features, or other locations that will not drain off site. Where this approach is not possible, a shallow earthen wash basin will be excavated away from ditches to receive the wash water

➤ **Spill Control Practices**

In addition to the good housekeeping and material management practices discussed in the previous sections of this plan, the following practices will be followed for spill prevention and cleanup:

- Manufacturers' recommended methods for spill cleanup will be clearly posted. All personnel will be made aware of procedures and the location of the information and cleanup supplies.
- Materials and equipment necessary for spill cleanup will be kept in the material storage area. Equipment and materials will include as appropriate, brooms, dust pans, mops, rags, gloves, oil absorbents, sand, sawdust, and plastic and metal trash containers.
- All spills will be cleaned up immediately after discovery.
- The spill area will be kept well ventilated and personnel will wear appropriate protective clothing to prevent injury from contact with a hazardous substance.
- Spills of toxic or hazardous material will be reported to the appropriate state/local agency as required by KRS 224 and applicable federal law.
- The spill prevention plan will be adjusted as needed to prevent spills from reoccurring and improve spill response and cleanup.
- Spills of products will be cleaned up promptly. Wastes from spill clean up will be disposed in accordance with appropriate regulations.

D. Other State and Local Plans

This BMP plan shall include any requirements specified in sediment and erosion control plans, storm water management plans or permits that have been approved by other state or local officials. Upon submittal of the NOI, other requirements for surface water protection are incorporated by reference into and are enforceable under this permit (even if they are not specifically included in this BMP plan). This provision does not apply to master or comprehensive plans, non-enforceable guidelines or technical guidance documents that are not identified in a specific plan or permit issued for the construction site by state or local officials. (1)

KyTC BMP Plan for Project CID ## -

E. Maintenance

1. The BMP plan shall include a clear description of the maintenance procedures necessary to keep the control measures in good and effective operating condition.
- Maintenance of BMPs during construction shall be a result of weekly and post rain event inspections with action being taken by the contractor to correct deficiencies.
 - Post Construction maintenance will be a function of normal highway maintenance operations. Following final project acceptance by the cabinet, district highway crews will be responsible for identification and correction of deficiencies regarding ground cover and cleaning of storm water BMPs. The project manager shall identify any BMPs that will be for the purpose of post construction storm water management with specific guidance for any non-routine maintenance. (1)

F. Inspections

Inspection and maintenance practices that will be used to maintain erosion and sediment controls:

- All erosion prevention and sediment control measures will be inspected at least once each week and following any rain of one-half inch or more.
- Inspections will be conducted by individuals that have successfully completed the KEPSC-RI course as required by Section 213.02.02 of the Standard Specifications for Road and Bridge Construction, current edition.
- Inspection reports will be written, signed, dated, and kept on file.
- Areas at final grade will be seeded and mulched within 14 days.
- Areas that are not at final grade where construction has ceased for a period of 21 days or longer and soil stock piles shall receive temporary mulch no later than 14 days from the last construction activity in that area.
- All measures will be maintained in good working order; if a repair is necessary, it will be initiated within 24 hours of being reported.
- Built-up sediment will be removed from behind the silt fence before it has reached halfway up the height of the fence.
- Silt fences will be inspected for bypassing, overtopping, undercutting, depth of sediment, tears, and to ensure attachment to secure posts.

KyTC BMP Plan for Project CID ## -

- Sediment basins will be inspected for depth of sediment, and built-up sediment will be removed when it reaches 50 percent of the design capacity and at the end of the job.
- Diversion dikes and berms will be inspected and any breaches promptly repaired. Areas that are eroding or scouring will be repaired and re-seeded / mulched as needed.
- Temporary and permanent seeding and mulching will be inspected for bare spots, washouts, and healthy growth. Bare or eroded areas will be repaired as needed.
- All material storage and equipment servicing areas that involve the management of bulk liquids, fuels, and bulk solids will be inspected weekly for conditions that represent a release or possible release of pollutants to the environment.

G. Non – Storm Water discharges

It is expected that non-storm water discharges may occur from the site during the construction period. Examples of non-storm water discharges include:

- Water from water line flushings.
- Water from cleaning concrete trucks and equipment.
- Pavement wash waters (where no spills or leaks of toxic or hazardous materials have occurred).
- Uncontaminated groundwater and rain water (from dewatering during excavation).

All non-storm water discharges will be directed to the sediment basin or to a filter fence enclosure in a flat vegetated infiltration area or be filtered via another approved commercial product.

H. Groundwater Protection Plan (3)

This plan serves as the groundwater protection plan as required by 401 KAR 5:037.

- Contractors statement: (3)

The following activities, as enumerated by 401 KAR 5:037 Section 2 that require the preparation and implementation of a groundwater protection plan, will or may be may be conducted as part of this construction project:

KyTC BMP Plan for Project CID ## -

_____ 2. (e) land treatment or land disposal of a pollutant;

_____ 2. (f) Storing, ..., or related handling of hazardous waste, solid waste or special waste, ..., in tanks, drums, or other containers, or in piles, (This does not include wastes managed in a container placed for collection and removal of municipal solid waste for disposal off site);

_____ 2. (g) Handling of materials in bulk quantities (equal or greater than 55 gallons or 100 pounds net dry weight transported held in an individual container) that, if released to the environment, would be a pollutant;

_____ 2. (j) Storing or related handling of road oils, dust suppressants,, at a central location;

_____ 2. (k) Application or related handling of road oils, dust suppressants or deicing materials, (does not include use of chloride-based deicing materials applied to roads or parking lots);

_____ 2. (m) Installation, construction, operation, or abandonment of wells, bore holes, or core holes, (this does not include bore holes for the purpose of explosive demolition);

Or, check the following only if there are no qualifying activities

_____ There are no activities for this project as listed in 401 KAR 5:037 Section 2 that require the preparation and implementation of a groundwater protection plan.

The contractor is responsible for the preparation of a plan that addresses the

401 KAR 5:037 Section 3. (3) Elements of site specific groundwater protection plan:

- (a) General information about this project is covered in the Project information;
- (b) Activities that require a groundwater protection plan have been identified above;
- (c) Practices that will protect groundwater from pollution are addressed in section C. Other control measures.
- (d) Implementation schedule – all practices required to prevent pollution of groundwater are to be in place prior to conducting the activity;
- (e) Training is required as a part of the ground water protection plan. All employees of the contractor, sub-contractor and resident engineer personnel will be trained to understand the nature and requirements of this plan as they pertain to their job

KyTC BMP Plan for Project CID ## -

function(s). Training will be accomplished within one week of employment and annually thereafter. A record of training will be maintained by the contractor with a copy provide to the resident engineer.

- (f) Areas of the project and groundwater plan activities will be inspected as part of the weekly sediment and erosion control inspections
- (g) Certification (see signature page.)

KyTC BMP Plan for Project CID ## - #####

Sub-Contractor Certification

The following sub-contractor shall be made aware of the BMP plan and responsible for implementation of BMPs identified in this plan as follows:

Subcontractor

Name:
Address:
Address:

Phone:

The part of BMP plan this subcontractor is responsible to implement is:

I certify under penalty of law that I understand the terms and conditions of the general Kentucky Pollutant Discharge Elimination System permit that authorizes the storm water discharges, the BMP plan that has been developed to manage the quality of water to be discharged as a result of storm events associated with the construction site activity and management of non-storm water pollutant sources identified as part of this certification.

Signed _____ title _____, _____
Typed or printed name¹ signature

1. Sub Contractor Note: to be signed by a person who is the owner, a responsible corporate officer, a general partner or the proprietor or a person designated to have the authority to sign reports by such a person in accordance with 401 KAR 5:060 Section 9. This delegation shall be in writing to: Manager, KPDES Branch, Division of Water, 14 Reilly Road, Frankfort Kentucky 40601. Reference the Project Control Number (PCN) and KPDES number when one has been issued.

SPECIAL NOTE

Filing of eNOI for KPDES Construction Stormwater Permit

County: Hardin

Route: KY 361

Item No.: 4-7020

KDOW Submittal ID: 60cef493-ed6b-44be-8d97-
e26cc4c2ec98

Project Description: Relocate Intersection of Woodland Drive at US 31W

A Notice of Intent for obtaining coverage under the Kentucky Pollutant Discharge Elimination System (KPDES) General Permit for Stormwater Discharges Associated with Construction Activities (KYR10) has been drafted, copy of which is attached. Upon award, the Contractor will be identified in Section III of the form as the “Building Contractor” and it will be submitted for approval to the Kentucky Division of Water. The Contractor shall be responsible for advancing the work in a manner that is compliant with all applicable and appropriate KYTC specifications for sediment and erosion control as well as meeting the requirements of the KYR10 permit and the KDOW.

If there are any questions regarding this note, please contact David Waldner, Director, Division of Environmental Analysis, TCOB, 200 Mero Street, Frankfort, KY 40622, Phone: (502) 564-7250.

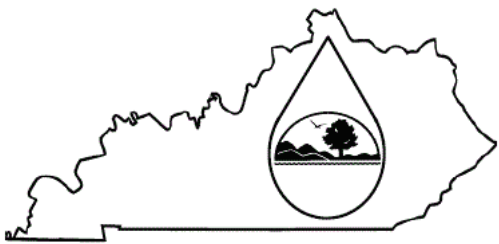
	<h2 style="margin: 0;">KENTUCKY POLLUTION DISCHARGE ELIMINATION SYSTEM (KPDES)</h2> <p style="margin: 5px 0;">Notice of Intent (NOI) for coverage of Storm Water Discharge Associated with Construction Activities Under the KPDES Storm Water General Permit KYR100000</p> <p style="margin: 5px 0;">Click here for Instructions (Controls/KPDES_FormKYR10_Instructions.htm)</p> <p style="margin: 5px 0;">Click here to obtain information and a copy of the KPDES General Permit. (http://dep.ky.gov/formslibrary/Documents/KYR10PermitPage.pdf)</p> <p style="margin: 5px 0; font-size: small;">(*) indicates a required field; (✓) indicates a field may be required based on user input or is an optionally required field</p>
---	---

Reason for Submittal:(*) <input type="text" value="Application for New Permit Coverage"/>	Agency Interest ID: <input type="text" value="Agency Interest ID"/>	Permit Number:(✓) <input type="text" value="KPDES Permit Number"/>
--	--	---

If change to existing permit coverage is requested, describe the changes for which modification of coverage is being sought:(✓)

ELIGIBILITY:
Stormwater discharges associated with construction activities disturbing individually one (1) acre or more, including, in the case of a common plan of development, contiguous construction activities that cumulatively equal one (1) acre or more of disturbance.

EXCLUSIONS:
The following are excluded from coverage under this general permit:

- 1) Are conducted at or on properties that have obtained an individual KPDES permit for the discharge of other wastewaters which requires the development and implementation of a Best Management Practices (BMP) plan;
- 2) Any operation that the DOW determines an individual permit would better address the discharges from that operation;
- 3) Any project that discharges to an Impaired Water listed in the most recent Integrated Report, §305(b) as impaired for sediment and for which an approved TMDL has been developed.

SECTION I -- FACILITY OPERATOR INFORMATION (PERMITTEE)

Company Name:(✓) <input type="text" value="KYTC District 4"/>	First Name:(✓) <input type="text" value="Paul"/>	M.I.: <input type="text" value="MI"/>	Last Name:(✓) <input type="text" value="Sanders"/>
Mailing Address:(*) <input type="text" value="634 East Dixie Ave"/>	City:(*) <input type="text" value="Elizabethtown"/>	State:(*) <input type="text" value="Kentucky"/>	Zip:(*) <input type="text" value="42701"/>
eMail Address:(*) <input type="text" value="Paul.Sanders@ky.gov"/>	Business Phone:(*) <input type="text" value="2707665066"/>	Alternate Phone: <input type="text" value="Phone"/>	

SECTION II -- GENERAL SITE LOCATION INFORMATION

Project Name:(*) <input type="text" value="4-7020"/>	Status of Owner/Operator(*) <input type="text" value="State Government"/>	SIC Code(*) <input type="text" value="1611 Highway and Street Const"/>
Company Name:(✓) <input type="text" value="KYTC Department of Highways District 4"/>	First Name:(✓) <input type="text" value="Paul"/>	M.I.: <input type="text" value="MI"/>
Last Name:(✓) <input type="text" value="Sanders"/>		
Site Physical Address:(*) <input type="text" value="KY 361 @ US 31W"/>		
City:(*) <input type="text" value="Elizabethtown"/>	State:(*) <input type="text" value="Kentucky"/>	Zip:(*) <input type="text" value="42701"/>
County:(*) <input type="text" value="Hardin"/>	Latitude(decimal degrees)(*)DMS to DD Converter (https://www.fcc.gov/media/radio/dms-decimal) <input type="text" value="37.709722"/>	Longitude(decimal degrees)(*) <input type="text" value="-85.882222"/>

SECTION III -- SPECIFIC SITE ACTIVITY INFORMATION

Project Description:(*)

a. For single projects provide the following information

Total Number of Acres in Project:(√) <input style="width:95%;" type="text" value="6.3"/>	Total Number of Acres Disturbed:(√) <input style="width:95%;" type="text" value="6.3"/>
Anticipated Start Date:(√) <input style="width:95%;" type="text"/>	Anticipated Completion Date:(√) <input style="width:95%;" type="text"/>

b. For common plans of development provide the following information

Total Number of Acres in Project:(√) <input style="width:95%;" type="text" value="# Acre(s)"/>	Total Number of Acres Disturbed:(√) <input style="width:95%;" type="text" value="# Acre(s)"/>
Number of individual lots in development, if applicable:(√) <input style="width:95%;" type="text" value="# lot(s)"/>	Number of lots in development:(√) <input style="width:95%;" type="text" value="# lot(s)"/>
Total acreage of lots intended to be developed:(√) <input style="width:95%;" type="text" value="Project Acres"/>	Number of acres intended to be disturbed at any one time:(√) <input style="width:95%;" type="text" value="Disturbed Acres"/>
Anticipated Start Date:(√) <input style="width:95%;" type="text"/>	Anticipated Completion Date:(√) <input style="width:95%;" type="text"/>

List Building Contractor(s) at the time of Application:(*)

	Company Name		
+			

SECTION IV -- IF THE PERMITTED SITE DISCHARGES TO A WATER BODY THE FOLLOWING INFORMATION IS REQUIRED ?

Discharge Point(s):

	Unnamed Tributary?	Latitude	Longitude	Receiving Water Name	
1	Yes	37.70981	-85.882049	Shaw Creek	Delete
2	Yes	37.709549	-85.880931	Shaw Creek	Delete
3	Yes	37.709362	-85.882206	Shaw Creek	Delete
4	Yes	37.708927	-85.881108	Freeman Creek	Delete
5	Yes	37.708485	-85.880218	Freeman Creek	Delete
6	Yes	37.709296	-85.879525	Freeman Creek	Delete
7	Yes	37.709531	-85.876841	Freeman Creek	Delete
8	Yes	37.709189	-85.8763	Freeman Creek	Delete
9	Yes	37.708724	-85.874314	Freeman Creek	Delete
10	Yes	37.707941	-85.875019	Freeman Creek	Delete

SECTION V -- IF THE PERMITTED SITE DISCHARGES TO A MS4 THE FOLLOWING INFORMATION IS REQUIRED ?

Name of MS4:

Date of application/notification to the MS4 for construction site permit coverage:

Discharge Point(s):(*)

	Latitude	Longitude	
3	37.709296	-85.879525	Delete
4	37.709531	-85.876841	Delete
5	37.709189	-85.8763	Delete
6	37.708724	-85.874314	Delete
7	37.707941	-85.875019	Delete
8	37.70765	-85.87551	Delete
9	37.707226	-85.873436	Delete
10	37.70981	-85.882049	Delete
11	37.709549	-85.880931	Delete
12	37.709362	-85.882206	Delete

SECTION VI -- WILL THE PROJECT REQUIRE CONSTRUCTION ACTIVITIES IN A WATER BODY OR THE RIPARIAN ZONE?

Will the project require construction activities in a water body or the riparian zone?: (*)	<input style="width:95%;" type="text" value="No"/>
If Yes, describe scope of activity: (√)	<input style="width:95%;" type="text" value="describe scope of activity"/>
Is a Clean Water Act 404 permit required?:(*)	<input style="width:95%;" type="text" value="No"/>

Is a Clean Water Act 401 Water Quality Certification required?:(*)	No
--	----

SECTION VII -- NOI PREPARER INFORMATION			
First Name:(*) Joseph	M.I.: M	Last Name:(*) Ferguson	Company Name:(*) KYTC Department of Highways District 4
Mailing Address:(*) 634 East Dixie Ave	City:(*) Elizabethtown	State:(*) Kentucky	Zip:(*) 42701
eMail Address:(*) joseph.ferguson@ky.gov	Business Phone:(*) 2707665066	Alternate Phone: Phone	

SECTION VIII -- ATTACHMENTS	
Facility Location Map:(*)	<input type="button" value="Upload file"/>
Supplemental Information:	<input type="button" value="Upload file"/>

SECTION IX -- CERTIFICATION			
I certify under penalty of law that this document and all attachments were prepared under my direction or supervision in accordance with a system designed to assure that qualified personnel properly gather and evaluate the information submitted. Based on my inquiry of the person or persons who manage the system, or those persons directly responsible for gathering the information submitted is, to the best of my knowledge and belief, true, accurate, and complete. I am aware that there are significant penalties for submitting false information, including the possibility of fine and imprisonment for knowing violations.			
Signature:(*) Signature		Title:(*) Title	
First Name:(*) First Name	M.I.: MI	Last Name:(*) Last Name	
eMail Address:(*) eMail Address	Business Phone:(*) Phone	Alternate Phone: Phone	Signature Date:(*) Date

<input type="button" value="Click to Save Values for Future Retrieval"/>	<input type="button" value="Click to Submit to EEC"/>
--	---

4-7020 - KY 361 KPDES Map

Id	Latitude	Longitude
1	37.70981	-85.882049
2	37.709549	-85.880931
3	37.709362	-85.882206
4	37.708927	-85.881108
5	37.708485	-85.880218
6	37.709296	-85.879525
7	37.709531	-85.876841
8	37.709189	-85.8763
9	37.708724	-85.874314
10	37.707941	-85.875019
11	37.70765	-85.873551
12	37.707226	-85.873436

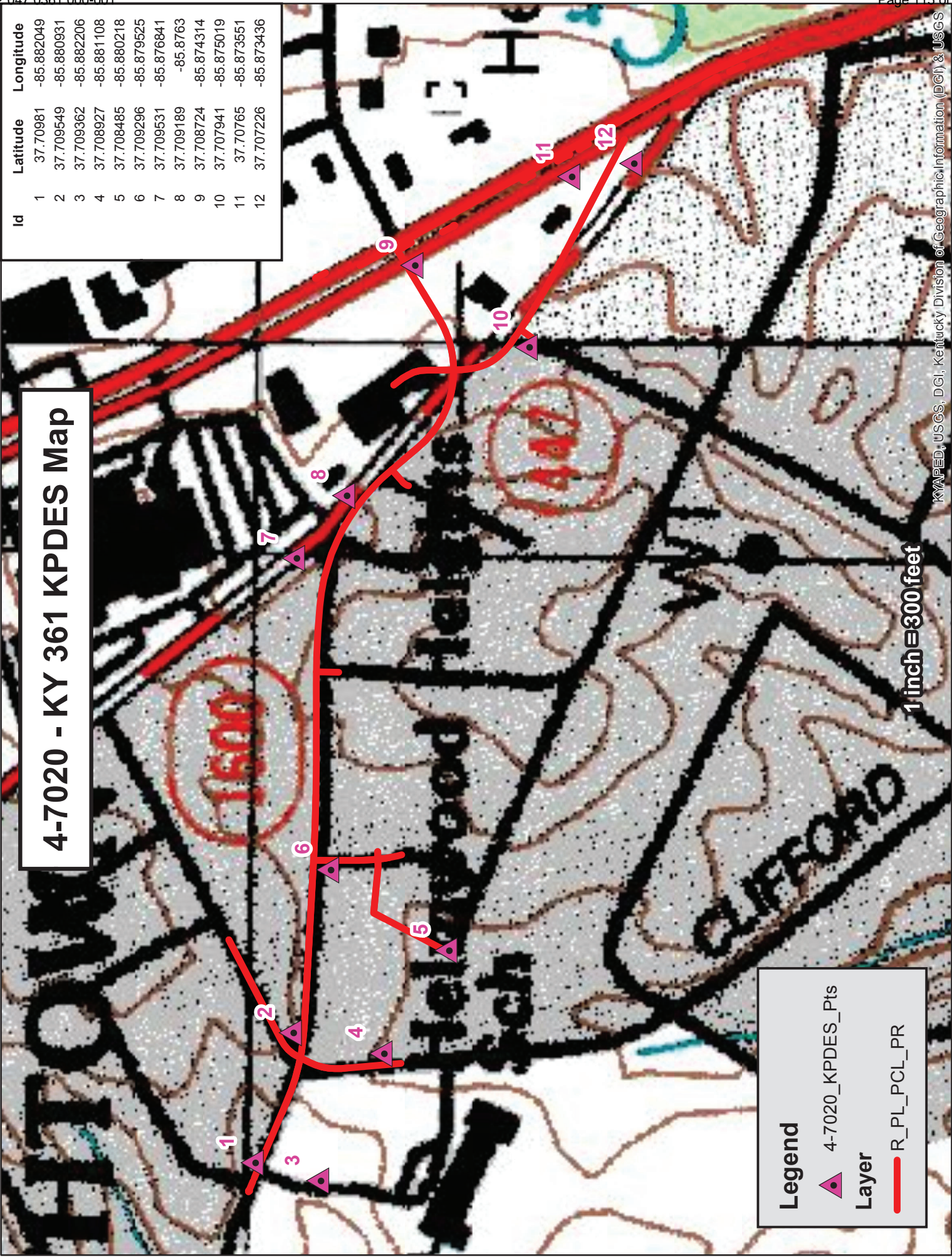

Legend

- 4-7020_KPDES_Pts
- Layer**
- R_PL_PCL_PR

1 inch = 300 feet



Item Number: 04-7020.00 **Contract ID:** Unavailable **County:** HARDIN
Letting Date: 05/24/2019 **Project Manager:** kytc\Bradley.Bottoms
Description:
 RELOCATE INTERSECTION OF WOODLAND DRIVE AT US-31W. (98CCN)(06CCR)(REMAINING FUNDS FOR AGREEMENT)(12CCR)
 (LET BY KYTC)

Info: Welcome to the Clear View Production site. All changes here will affect Production SYP.

Search Project Reports

- Milestones
- Funding
- CAP
- Evaluations
- Details

Open CAP Report

#	Requestor	Location	Request Date	CAP Description	Modified By	Modified
1	John Kelley Mouser	Parcel 18	05/15/2018	Contractor shall remove 36" Ash tree at 23+70.18. Should roots of other trees outside of the proposed Right of Way and Easement be disturbed, contractor shall remove those trees, provided the property owner allows access by consent, and dress and sow the disturbed area.	ky\bradley.bottoms	06/05/2018
2	Diane Logsdon	Parcel 21	10/13/2017	Contractor shall take reasonable precautions as necessary to prevent disturbance to 36" Hickory Tree and 24" Shag Bark Hickory. However, if roots are damaged contractor shall contact owner and remove trees and stumps and has permission to work outside of temporary easement per consent release, if necessary for removal of tree. Contractor shall contact property owner prior to asphalt work on driveway.	ky\bradley.bottoms	08/31/2018

New

PART II
SPECIFICATIONS AND STANDARD DRAWINGS

SPECIFICATIONS REFERENCE

Any reference in the plans or proposal to previous editions of the *Standard Specifications for Road and Bridge Construction* and *Standard Drawings* are superseded by *Standard Specifications for Road and Bridge Construction, Edition of 2012* and *Standard Drawings, Edition of 2016*.

SUPPLEMENTAL SPECIFICATIONS

The contractor shall use the Supplemental Specifications that are effective at the time of letting.
The Supplemental Specifications can be found at the following link:

<http://transportation.ky.gov/Construction/Pages/Kentucky-Standard-Specifications.aspx>

SPECIAL NOTE FOR PORTABLE CHANGEABLE MESSAGE SIGNS

This Special Note will apply when indicated on the plans or in the proposal.

1.0 DESCRIPTION. Furnish, install, operate, and maintain variable message signs at the locations shown on the plans or designated by the Engineer. Remove and retain possession of variable message signs when they are no longer needed on the project.

2.0 MATERIALS.

2.1 General. Use LED Variable Message Signs Class I, II, or III, as appropriate, from the Department's List of Approved Materials.

Unclassified signs may be submitted for approval by the Engineer. The Engineer may require a daytime and nighttime demonstration. The Engineer will make a final decision within 30 days after all required information is received.

2.2 Sign and Controls. All signs must:

- 1) Provide 3-line messages with each line being 8 characters long and at least 18 inches tall. Each character comprises 35 pixels.
- 2) Provide at least 40 preprogrammed messages available for use at any time. Provide for quick and easy change of the displayed message; editing of the message; and additions of new messages.
- 3) Provide a controller consisting of:
 - a) Keyboard or keypad.
 - b) Readout that mimics the actual sign display. (When LCD or LCD type readout is used, include backlighting and heating or otherwise arrange for viewing in cold temperatures.)
 - c) Non-volatile memory or suitable memory with battery backup for storing pre-programmed messages.
 - d) Logic circuitry to control the sequence of messages and flash rate.
- 4) Provide a serial interface that is capable of supporting complete remote control ability through land line and cellular telephone operation. Include communication software capable of immediately updating the message, providing complete sign status, and allowing message library queries and updates.
- 5) Allow a single person easily to raise the sign to a satisfactory height above the pavement during use, and lower the sign during travel.
- 6) Be Highway Orange on all exterior surfaces of the trailer, supports, and controller cabinet.
- 7) Provide operation in ambient temperatures from -30 to + 120 degrees Fahrenheit during snow, rain and other inclement weather.
- 8) Provide the driver board as part of a module. All modules are interchangeable, and have plug and socket arrangements for disconnection and reconnection. Printed circuit boards associated with driver boards have a conformable coating to protect against moisture.
- 9) Provide a sign case sealed against rain, snow, dust, insects, etc. The lens is UV stabilized clear plastic (polycarbonate, acrylic, or other approved material) angled to prevent glare.
- 10) Provide a flat black UV protected coating on the sign hardware, character PCB, and appropriate lens areas.
- 11) Provide a photocell control to provide automatic dimming.

- 12) Allow an on-off flashing sequence at an adjustable rate.
- 13) Provide a sight to aim the message.
- 14) Provide a LED display color of approximately 590 nm amber.
- 15) Provide a controller that is password protected.
- 16) Provide a security device that prevents unauthorized individuals from accessing the controller.
- 17) Provide the following 3-line messages preprogrammed and available for use when the sign unit begins operation:

/KEEP/RIGHT/=>=>=>/	/MIN/SPEED/**MPH/
/KEEP/LEFT/<=<=<=</	/ICY/BRIDGE/AHEAD/ /ONE
/LOOSE/GRAVEL/AHEAD/	LANE/BRIDGE/AHEAD/
/RD WORK/NEXT/**MILES/	/ROUGH/ROAD/AHEAD/
/TWO WAY/TRAFFIC/AHEAD/	/MERGING/TRAFFIC/AHEAD/
/PAINT/CREW/AHEAD/	/NEXT/***/MILES/
/REDUCE/SPEED/**MPH/	/HEAVY/TRAFFIC/AHEAD/
/BRIDGE/WORK/***0 FT/	/SPEED/LIMIT/**MPH/
/MAX/SPEED/**MPH/	/BUMP/AHEAD/
/SURVEY/PARTY/AHEAD/	/TWO/WAY/TRAFFIC/

*Insert numerals as directed by the Engineer.
Add other messages during the project when required by the Engineer.

2.3 Power.

- 1) Design solar panels to yield 10 percent or greater additional charge than sign consumption. Provide direct wiring for operation of the sign or arrow board from an external power source to provide energy backup for 21 days without sunlight and an on-board system charger with the ability to recharge completely discharged batteries in 24 hours.

3.0 CONSTRUCTION. Furnish and operate the variable message signs as designated on the plans or by the Engineer. Ensure the bottom of the message panel is a minimum of 7 feet above the roadway in urban areas and 5 feet above in rural areas when operating. Use Class I, II, or III signs on roads with a speed limit less than 55 mph. Use Class I or II signs on roads with speed limits 55 mph or greater.

Maintain the sign in proper working order, including repair of any damage done by others, until completion of the project. When the sign becomes inoperative, immediately repair or replace the sign. Repetitive problems with the same unit will be cause for rejection and replacement.

Use only project related messages and messages directed by the Engineer, unnecessary messages lessen the impact of the sign. Ensure the message is displayed in either one or 2 phases with each phase having no more than 3 lines of text. When no message is needed, but it is necessary to know if the sign is operable, flash only a pixel.

When the sign is not needed, move it outside the clear zone or where the Engineer directs. Variable Message Signs are the property of the Contractor and shall be removed from the project when no longer needed. The Department will not assume ownership of these signs.

4.0 MEASUREMENT. The final quantity of Variable Message Sign will be

11

the actual number of individual signs acceptably furnished and operated during the project. The Department will not measure signs replaced due to damage or rejection.

5.0 PAYMENT. The Department will pay for the Variable Message Signs at the unit price each. The Department will not pay for signs replaced due to damage or rejection. Payment is full compensation for furnishing all materials, labor, equipment, and service necessary to, operate, move, repair, and maintain or replace the variable message signs. The Department will make payment for the completed and accepted quantities under the following:

<u>Code</u>	<u>Pay Item</u>	<u>Pay Unit</u>
02671	Portable Changeable Message Sign	Each

Effective June 15, 2012

SPECIAL NOTE FOR LONGITUDINAL PAVEMENT JOINT ADHESIVE

1. DESCRIPTION. This specification covers the requirements and practices for applying an asphalt adhesive material to the longitudinal joint of the surface course of an asphalt pavement. Apply the adhesive to the face of longitudinal joint between driving lanes for the first lane paved. Then, place and compact the adjacent lane against the treated face to produce a strong, durable, waterproof longitudinal joint.
2. MATERIALS, EQUIPMENT, AND PERSONNEL.

2.1 Joint Adhesive. Provide material conforming to Subsection 2.1.1.

2.1.1 Provide an adhesive conforming to the following requirements:

Property	Specification	Test Procedure
Viscosity, 400 ° F (Pa·s)	4.0 – 10.0	ASTM D 4402
Cone Penetration, 77 ° F	60 – 100	ASTM D 5329
Flow, 140 ° F (mm)	5.0 max.	ASTM D 5329
Resilience, 77 ° F (%)	30 min.	ASTM D 5329
Ductility, 77 ° F (cm)	30.0 min.	ASTM D 113
Ductility, 39 ° F (cm)	30.0 min.	ASTM D 113
Tensile Adhesion, 77 ° F (%)	500 min.	ASTM D 5329, Type II
Softening Point, ° F	171 min.	AASHTO T 53
Asphalt Compatibility	Pass	ASTM D 5329

Ensure the temperature of the pavement joint adhesive is between 380 and 410 °F when the material is extruded in a 0.125-inch-thick band over the entire face of the longitudinal joint.

2.2. Equipment.

2.2.1 Melter Kettle. Provide an oil-jacketed, double-boiler, melter kettle equipped with any needed agitation and recirculating systems.

2.2.2 Applicator System. Provide a pressure-feed-wand applicator system with an applicator shoe attached.

2.3 Personnel. Ensure a technical representative from the manufacturer of the pavement joint adhesive is present during the initial construction activities and available upon the request of the Engineer.

3. CONSTRUCTION.

3.1 Surface Preparation. Prior to the application of the pavement joint adhesive, ensure the face of the longitudinal joint is thoroughly dry and free from dust or any other debris that would inhibit adhesion. Clean the joint face by the use of compressed air.

11N

Ensure this preparation process occurs shortly before application to prevent the return of debris on the joint face.

3.2 Pavement Joint Adhesive Application. Ensure the ambient temperature is a minimum of 40 ° F during the application of the pavement joint adhesive. Prior to applying the adhesive, demonstrate competence in applying the adhesive according to this note to the satisfaction of the Engineer. Heat the adhesive in the melter kettle to the specified temperature range. Pump the adhesive from the melter kettle through the wand onto the vertical face of the cold joint. Apply the adhesive in a continuous band over the entire face of the longitudinal joint. Do not use excessive material in either thickness or location. Ensure the edge of the extruded adhesive material is flush with the surface of the pavement. Then, place and compact the adjacent lane against the joint face. Remove any excessive material extruded from the joint after compaction (a small line of material may remain).

3.3 Pavement Joint Adhesive Certification. Furnish the joint adhesive's certification to the Engineer stating the material conforms to all requirements herein prior to use.

3.4 Sampling and Testing. The Department will require a random sample of pavement joint adhesive from each manufacturer's lot of material. Extrude two 5 lb. samples of the heated material and forward the sample to the Division of Materials for testing. Reynolds oven bags, turkey size, placed inside small cardboard boxes or cement cylinder molds have been found suitable. Ensure the product temperature is 400°F or below at the time of sampling.

4. MEASUREMENT. The Department will measure the quantity of Pavement Joint Adhesive in linear feet. The Department will not measure for payment any extra materials, labor, methods, equipment, or construction techniques used to satisfy the requirements of this note. The Department will not measure for payment any trial applications of Pavement Joint Adhesive, the cleaning of the joint face, or furnishing and placing the adhesive. The Department will consider all such items incidental to the Pavement Joint Adhesive.
5. PAYMENT. The Department will pay for the Pavement Joint Adhesive at the Contract unit bid price and apply an adjustment for each manufacturer's lot of material based on the degree of compliance as defined in the following schedule. When a sample fails on two or more tests, the Department may add the deductions, but the total deduction will not exceed 100 percent.

11N

Pavement Joint Adhesive Price Adjustment Schedule						
Test	Specification	100% Pay	90% Pay	80% Pay	50% Pay	0% Pay
Joint Adhesive Referenced in Subsection 2.1.1						
Viscosity, 400 ° F (Pa•s) ASTM D 3236	4.0-10.0	3.5-10.5	3.0-3.4 10.6-11.0	2.5-2.9 11.1-11.5	2.0-2.4 11.6-12.0	≤1.9 ≥ 12.1
Cone Penetration, 77 ° F ASTM D 5329	60-100	57-103	54-56 104-106	51-53 107-109	48-50 110-112	≤ 47 ≥ 113
Flow, 140 ° F (mm) ASTM D 5329	≤ 5.0	≤ 5.5	5.6-6.0	6.1-6.5	6.6-7.0	≥ 7.1
Resilience, 77 ° F (%) ASTM D 5329	≥ 30	≥ 28	26-27	24-25	22-23	≤ 21
Tensile Adhesion, 77 ° F (%) ASTM D 5329	≥ 500	≥ 490	480-489	470-479	460-469	≤ 459
Softening Point, ° F AASHTO T 53	≥ 171	≥ 169	166-168	163-165	160-162	≤ 159
Ductility, 77 ° F (cm) ASTM D 113	≥ 30.0	≥ 29.0	28.0-28.9	27.0-27.9	26.0-26.9	≤ 25.9
Ductility, 39 ° F (cm) ASTM D 113	≥ 30.0	≥ 29.0	28.0-28.9	27.0-27.9	26.0-26.9	≤ 25.9

Code
20071EC

Pay Item
Joint Adhesive

Pay Unit
Linear Foot

May 7, 2014

PART III

EMPLOYMENT, WAGE AND RECORD REQUIREMENTS

**TRANSPORTATION CABINET
DEPARTMENT OF HIGHWAYS**

**LABOR AND WAGE REQUIREMENTS
APPLICABLE TO OTHER THAN FEDERAL-AID SYSTEM PROJECTS**

- I. Application
- II. Nondiscrimination of Employees (KRS 344)

I. APPLICATION

1. These contract provisions shall apply to all work performed on the contract by the contractor with his own organization and with the assistance of workmen under his immediate superintendence and to all work performed on the contract by piecework, station work or by subcontract. The contractor's organization shall be construed to include only workmen employed and paid directly by the contractor and equipment owned or rented by him, with or without operators.

2. The contractor shall insert in each of his subcontracts all of the stipulations contained in these Required Provisions and such other stipulations as may be required.

3. A breach of any of the stipulations contained in these Required Provisions may be grounds for termination of the contract.

3. If the contractor is in control of apprenticeship or other training or retraining, including on-the-job training programs, he shall not discriminate against an individual because of his race, color, religion, national origin, sex, disability or age forty (40) and over, in admission to, or employment in any program established to provide apprenticeship or other training.

4. The contractor will send to each labor union or representative of workers with which he has a collective bargaining agreement or other contract or understanding, a notice to be provided advising the said labor union or workers' representative of the contractor's commitments under this section, and shall post copies of the notice in conspicuous places available to employees and applicants for employment. The contractor will take such action with respect to any subcontract or purchase order as the administrating agency may direct as a means of enforcing such provisions, including sanctions for non-compliance.

Revised: January 25, 2017

II. NONDISCRIMINATION OF EMPLOYEES

**AN ACT OF THE KENTUCKY
GENERAL ASSEMBLY TO PREVENT
DISCRIMINATION IN EMPLOYMENT
KRS CHAPTER 344
EFFECTIVE JUNE 16, 1972**

The contract on this project, in accordance with KRS Chapter 344, provides that during the performance of this contract, the contractor agrees as follows:

1. The contractor shall not fail or refuse to hire, or shall not discharge any individual, or otherwise discriminate against an individual with respect to his compensation, terms, conditions, or privileges of employment, because of such individual's race, color, religion, national origin, sex, disability or age (forty and above); or limit, segregate, or classify his employees in any way which would deprive or tend to deprive an individual of employment opportunities or otherwise adversely affect his status as an employee, because of such individual's race, color, religion, national origin, sex, disability or age forty (40) and over. The contractor agrees to post in conspicuous places, available to employees and applicants for employment, notices to be provided setting forth the provisions of this nondiscrimination clause.

2. The contractor shall not print or publish or cause to be printed or published a notice or advertisement relating to employment by such an employer or membership in or any classification or referral for employment by the employment agency, indicating any preference, limitation, specification, or discrimination, based on race, color, religion, national origin, sex, or age forty (40) and over, or because the person is a qualified individual with a disability, except that such a notice or advertisement may indicate a preference, limitation, or specification based on religion, national origin, sex, or age forty (40) and over, or because the person is a qualified individual with a disability, when religion, national origin, sex, or age forty (40) and over, or because the person is a qualified individual with a disability, is a bona fide occupational qualification for employment.

EXECUTIVE BRANCH CODE OF ETHICS

In the 1992 regular legislative session, the General Assembly passed and Governor Brereton Jones signed Senate Bill 63 (codified as KRS 11A), the Executive Branch Code of Ethics, which states, in part:

KRS 11A.040 (7) provides:

No present or former public servant shall, within six (6) months following termination of his office or employment, accept employment, compensation, or other economic benefit from any person or business that contracts or does business with, or is regulated by, the state in matters in which he was directly involved during the last thirty-six (36) months of his tenure. This provision shall not prohibit an individual from returning to the same business, firm, occupation, or profession in which he was involved prior to taking office or beginning his term of employment, or for which he received, prior to his state employment, a professional degree or license, provided that, for a period of six (6) months, he personally refrains from working on any matter in which he was directly involved during the last thirty-six (36) months of his tenure in state government. This subsection shall not prohibit the performance of ministerial functions, including but not limited to filing tax returns, filing applications for permits or licenses, or filing incorporation papers, nor shall it prohibit the former officer or public servant from receiving public funds disbursed through entitlement programs.

KRS 11A.040 (9) states:

A former public servant shall not represent a person or business before a state agency in a matter in which the former public servant was directly involved during the last thirty-six (36) months of his tenure, for a period of one (1) year after the latter of:

- a) The date of leaving office or termination of employment; or
- b) The date the term of office expires to which the public servant was elected.

This law is intended to promote public confidence in the integrity of state government and to declare as public policy the idea that state employees should view their work as a public trust and not as a way to obtain private benefits.

If you have worked for the executive branch of state government within the past six months, you may be subject to the law's prohibitions. The law's applicability may be different if you hold elected office or are contemplating representation of another before a state agency.

Also, if you are affiliated with a firm which does business with the state and which employs former state executive-branch employees, you should be aware that the law may apply to them.

In case of doubt, the law permits you to request an advisory opinion from the Executive Branch Ethics Commission, 3 Fountain Place, Frankfort, Kentucky 40601; telephone (502) 564-7954.

Revised: January 27, 2017

Kentucky Equal Employment Opportunity Act of 1978

The requirements of the Kentucky Equal Employment Opportunity Act of 1978 (KRS 45.560-45.640) shall apply to this Contract. The apparent low Bidder will be required to submit EEO forms to the Division of Construction Procurement, which will then forward to the Finance and Administration Cabinet for review and approval. No award will become effective until all forms are submitted and EEO/CC has certified compliance. The required EEO forms are as follows:

- EEO-1: Employer Information Report
- Affidavit of Intent to Comply
- Employee Data Sheet
- Subcontractor Report

These forms are available on the Finance and Administration's web page under ***Vendor Information, Standard Attachments and General Terms*** at the following address:
<https://www.eProcurement.ky.gov>.

Bidders currently certified as being in compliance by the Finance and Administration Cabinet may submit a copy of their approval letter in lieu of the referenced EEO forms.

For questions or assistance please contact the Finance and Administration Cabinet by email at **finance.contractcompliance@ky.gov** or by phone at 502-564-2874.

EMPLOYEE RIGHTS UNDER THE FAIR LABOR STANDARDS ACT

THE UNITED STATES DEPARTMENT OF LABOR WAGE AND HOUR DIVISION

FEDERAL MINIMUM WAGE

\$7.25 PER HOUR

BEGINNING JULY 24, 2009

OVERTIME PAY At least 1½ times your regular rate of pay for all hours worked over 40 in a workweek.

CHILD LABOR An employee must be at least **16** years old to work in most non-farm jobs and at least **18** to work in non-farm jobs declared hazardous by the Secretary of Labor.

Youths **14** and **15** years old may work outside school hours in various non-manufacturing, non-mining, non-hazardous jobs under the following conditions:

No more than

- **3** hours on a school day or **18** hours in a school week;
- **8** hours on a non-school day or **40** hours in a non-school week.

Also, work may not begin before **7 a.m.** or end after **7 p.m.**, except from June 1 through Labor Day, when evening hours are extended to **9 p.m.** Different rules apply in agricultural employment.

TIP CREDIT Employers of “tipped employees” must pay a cash wage of at least \$2.13 per hour if they claim a tip credit against their minimum wage obligation. If an employee’s tips combined with the employer’s cash wage of at least \$2.13 per hour do not equal the minimum hourly wage, the employer must make up the difference. Certain other conditions must also be met.

ENFORCEMENT The Department of Labor may recover back wages either administratively or through court action, for the employees that have been underpaid in violation of the law. Violations may result in civil or criminal action.

Employers may be assessed civil money penalties of up to \$1,100 for each willful or repeated violation of the minimum wage or overtime pay provisions of the law and up to \$11,000 for each employee who is the subject of a violation of the Act’s child labor provisions. In addition, a civil money penalty of up to \$50,000 may be assessed for each child labor violation that causes the death or serious injury of any minor employee, and such assessments may be doubled, up to \$100,000, when the violations are determined to be willful or repeated. The law also prohibits discriminating against or discharging workers who file a complaint or participate in any proceeding under the Act.

ADDITIONAL INFORMATION

- Certain occupations and establishments are exempt from the minimum wage and/or overtime pay provisions.
- Special provisions apply to workers in American Samoa and the Commonwealth of the Northern Mariana Islands.
- Some state laws provide greater employee protections; employers must comply with both.
- The law requires employers to display this poster where employees can readily see it.
- Employees under 20 years of age may be paid \$4.25 per hour during their first 90 consecutive calendar days of employment with an employer.
- Certain full-time students, student learners, apprentices, and workers with disabilities may be paid less than the minimum wage under special certificates issued by the Department of Labor.

For additional information:



1-866-4-USWAGE

(1-866-487-9243) TTY: 1-877-889-5627



WWW.WAGEHOUR.DOL.GOV

PART IV
INSURANCE

INSURANCE

The Contractor shall procure and maintain the following insurance in addition to the insurance required by law:

- 1) Commercial General Liability-Occurrence form – not less than \$2,000,000 General aggregate, \$2,000,000 Products & Completed Aggregate, \$1,000,000 Personal & Advertising, \$1,000,000 each occurrence.
- 2) Automobile Liability- \$1,000,000 per accident
- 3) Employers Liability:
 - a) \$100,000 Each Accident Bodily Injury
 - b) \$500,000 Policy limit Bodily Injury by Disease
 - c) \$100,000 Each Employee Bodily Injury by Disease
- 4) The insurance required above must be evidenced by a Certificate of Insurance and this Certificate of Insurance must contain one of the following statements:
 - a) "policy contains no deductible clauses."
 - b) "policy contains _____ (amount) deductible property damage clause but company will pay claim and collect the deductible from the insured."
- 5) **KENTUCKY WORKMEN'S COMPENSATION INSURANCE.** The contractor shall furnish evidence of coverage of all his employees or give evidence of self-insurance by submitting a copy of a certificate issued by the Workmen's Compensation Board.

The cost of insurance is incidental to all contract items. All subcontractors must meet the same minimum insurance requirements.

PART V
BID ITEMS

PROPOSAL BID ITEMS

191025

Page 1 of 3

Report Date 4/26/19

Section: 0001 - PAVING

LINE	BID CODE	ALT	DESCRIPTION	QUANTITY	UNIT	UNIT PRIC	FP	AMOUNT
0010	00003		CRUSHED STONE BASE	6,352.00	TON		\$	
0020	00190		LEVELING & WEDGING PG64-22	79.00	TON		\$	
0030	00212		CL2 ASPH BASE 1.00D PG64-22	4,007.00	TON		\$	
0040	00307		CL2 ASPH SURF 0.38B PG64-22	1,328.00	TON		\$	
0050	00356		ASPHALT MATERIAL FOR TACK	9.50	TON		\$	
0060	02084		JPC PAVEMENT-8 IN	301.00	SQYD		\$	
0070	02101		CEM CONC ENT PAVEMENT-8 IN	1,277.00	SQYD		\$	

Section: 0002 - ROADWAY

LINE	BID CODE	ALT	DESCRIPTION	QUANTITY	UNIT	UNIT PRIC	FP	AMOUNT
0080	01000		PERFORATED PIPE-4 IN	5,465.00	LF		\$	
0090	01015		INSPECT & CERTIFY EDGE DRAIN SYSTEM	1.00	LS		\$	
0100	01310		REMOVE PIPE	477.00	LF		\$	
0110	01585		REMOVE DROP BOX INLET	5.00	EACH		\$	
0120	01705		REMOVE CURB & GUTTER BOX INLET	4.00	EACH		\$	
0130	01740		CORED HOLE DRAINAGE BOX CON-4 IN	52.00	EACH		\$	
0140	01810		STANDARD CURB AND GUTTER	6,203.00	LF		\$	
0150	01812		REMOVE CURB AND GUTTER	857.00	LF		\$	
0160	01875		STANDARD HEADER CURB	792.00	LF		\$	
0170	02014		BARRICADE-TYPE III	6.00	EACH		\$	
0180	02016		REMOVE CONCRETE ISLAND	17.00	SQYD		\$	
0190	02091		REMOVE PAVEMENT	1,134.00	SQYD		\$	
0200	02159		TEMP DITCH	1,901.00	LF		\$	
0210	02160		CLEAN TEMP DITCH	951.00	LF		\$	
0220	02200		ROADWAY EXCAVATION	8,725.00	CUYD		\$	
0230	02203		STRUCTURE EXCAV-UNCLASSIFIED	55.00	CUYD		\$	
0240	02242		WATER	100.00	MGAL		\$	
0250	02429		RIGHT-OF-WAY MONUMENT TYPE 1	32.00	EACH		\$	
0260	02432		WITNESS POST	3.00	EACH		\$	
0270	02460		REMOVE TREES OR STUMPS	2.00	EACH		\$	
0280	02545		CLEARING AND GRUBBING .6.3 ACRES	1.00	LS		\$	
0290	02555		CONCRETE-CLASS B	58.00	CUYD		\$	
0300	02562		TEMPORARY SIGNS	93.00	SQFT		\$	
0310	02585		EDGE KEY	298.00	LF		\$	
0320	02611		HANDRAIL-TYPE A-1	99.00	LF		\$	
0330	02650		MAINTAIN & CONTROL TRAFFIC	1.00	LS		\$	
0340	02671		PORTABLE CHANGEABLE MESSAGE SIGN	2.00	EACH		\$	
0350	02676		MOBILIZATION FOR MILL & TEXT	1.00	LS		\$	
0360	02690		SAFELOADING	13.00	CUYD		\$	
0370	02701		TEMP SILT FENCE	1,901.00	LF		\$	
0380	02703		SILT TRAP TYPE A	11.00	EACH		\$	
0390	02704		SILT TRAP TYPE B	11.00	EACH		\$	
0400	02705		SILT TRAP TYPE C	11.00	EACH		\$	
0410	02706		CLEAN SILT TRAP TYPE A	11.00	EACH		\$	

PROPOSAL BID ITEMS

191025

Page 2 of 3

Report Date 4/26/19

LINE	BID CODE	ALT	DESCRIPTION	QUANTITY	UNIT	UNIT PRIC	FP	AMOUNT
0420	02707		CLEAN SILT TRAP TYPE B	11.00	EACH		\$	
0430	02708		CLEAN SILT TRAP TYPE C	11.00	EACH		\$	
0440	02720		SIDEWALK-4 IN CONCRETE	2,275.00	SQYD		\$	
0450	02726		STAKING	1.00	LS		\$	
0460	02998		MASONRY COATING	77.00	SQYD		\$	
0470	05950		EROSION CONTROL BLANKET	531.00	SQYD		\$	
0480	05952		TEMP MULCH	32,396.00	SQYD		\$	
0490	05953		TEMP SEEDING AND PROTECTION	24,297.00	SQYD		\$	
0500	05963		INITIAL FERTILIZER	1.00	TON		\$	
0510	05964		MAINTENANCE FERTILIZER	1.00	TON		\$	
0520	05985		SEEDING AND PROTECTION	2,922.00	SQYD		\$	
0530	05990		SODDING	6,808.00	SQYD		\$	
0540	05992		AGRICULTURAL LIMESTONE	7.00	TON		\$	
0550	06510		PAVE STRIPING-TEMP PAINT-4 IN	20,612.00	LF		\$	
0560	06514		PAVE STRIPING-PERM PAINT-4 IN	6,987.00	LF		\$	
0570	06565		PAVE MARKING-THERMO X-WALK-6 IN	379.00	LF		\$	
0580	06568		PAVE MARKING-THERMO STOP BAR-24IN	131.00	LF		\$	
0590	06569		PAVE MARKING-THERMO CROSS-HATCH	164.00	SQFT		\$	
0600	06574		PAVE MARKING-THERMO CURV ARROW	18.00	EACH		\$	
0610	06575		PAVE MARKING-THERMO COMB ARROW	3.00	EACH		\$	
0620	10020NS		FUEL ADJUSTMENT	9,329.00	DOLL	\$1.00	\$	\$9,329.00
0630	10030NS		ASPHALT ADJUSTMENT	18,516.00	DOLL	\$1.00	\$	\$18,516.00
0640	21289ED		LONGITUDINAL EDGE KEY	2,589.00	LF		\$	
0650	23158ES505		DETECTABLE WARNINGS	536.00	SQFT		\$	
0660	24489EC		INLAID PAVEMENT MARKER	119.00	EACH		\$	
0670	24814EC		PIPELINE INSPECTION	1,500.00	LF		\$	

Section: 0003 - DRAINAGE

LINE	BID CODE	ALT	DESCRIPTION	QUANTITY	UNIT	UNIT PRIC	FP	AMOUNT
0680	00440		ENTRANCE PIPE-15 IN	84.00	LF		\$	
0690	00443		ENTRANCE PIPE-24 IN	75.00	LF		\$	
0700	00521		STORM SEWER PIPE-15 IN	179.00	LF		\$	
0710	00522		STORM SEWER PIPE-18 IN	1,820.00	LF		\$	
0720	00524		STORM SEWER PIPE-24 IN	492.00	LF		\$	
0730	00526		STORM SEWER PIPE-30 IN	233.00	LF		\$	
0740	00981		SLOTTED DRAIN PIPE-15 IN	10.00	LF		\$	
0750	01210		PIPE CULVERT HEADWALL-30 IN	1.00	EACH		\$	
0760	01432		SLOPED BOX OUTLET TYPE 1-15 IN	1.00	EACH		\$	
0770	01456		CURB BOX INLET TYPE A	27.00	EACH		\$	
0780	01487		CURB BOX INLET TYPE F	5.00	EACH		\$	
0790	01493		DROP BOX INLET TYPE 2	2.00	EACH		\$	
0800	01496		DROP BOX INLET TYPE 3	2.00	EACH		\$	
0810	01529		DROP BOX INLET TYPE 6D	3.00	EACH		\$	
0820	01544		DROP BOX INLET TYPE 11	1.00	EACH		\$	
0830	01559		DROP BOX INLET TYPE 13G	2.00	EACH		\$	
0840	01577		DROP BOX INLET TYPE 14	1.00	EACH		\$	
0850	01581		DROP BOX INLET TYPE 16G	1.00	EACH		\$	

PROPOSAL BID ITEMS

191025

Page 3 of 3

Report Date 4/26/19

LINE	BID CODE	ALT	DESCRIPTION	QUANTITY	UNIT	UNIT PRIC	FP	AMOUNT
0860	01642		JUNCTION BOX-18 IN	1.00	EACH		\$	
0870	01650		JUNCTION BOX	1.00	EACH		\$	
0880	01756		MANHOLE TYPE A	3.00	EACH		\$	
0890	01761		MANHOLE TYPE B	1.00	EACH		\$	
0900	02600		FABRIC GEOTEXTILE TY IV FOR PIPE	7,505.00	SQYD	\$2.00	\$	\$15,010.00

Section: 0004 - UTILITY-GAS

LINE	BID CODE	ALT	DESCRIPTION	QUANTITY	UNIT	UNIT PRIC	FP	AMOUNT
0910	16023		G PIPE STEEL 02 INCH	1,175.00	LF		\$	
0920	16026		G PIPE STEEL 06 INCH	103.00	LF		\$	
0930	16031		G SERVICE LONG SIDE 1 OR 1-1/4 INCH	9.00	EACH		\$	
0940	16036		G SERVICE SHORT SIDE 1 OR 1-1/4 INCH	14.00	EACH		\$	
0950	16057		G VALVE STEEL 02 INCH	20.00	EACH		\$	
0960	16068		G MAIN ABANDON CARDINAL DR.	1.00	LS		\$	
0970	16068		G MAIN ABANDON CLIFFORD DR.	1.00	LS		\$	
0980	16077		G TIE-IN STEEL 02 INCH	7.00	EACH		\$	
0990	16080		G TIE-IN STEEL 06 INCH	2.00	EACH		\$	

Section: 0005 - SEWER

LINE	BID CODE	ALT	DESCRIPTION	QUANTITY	UNIT	UNIT PRIC	FP	AMOUNT
1000	02690		SAFELOADING	1.00	CUYD		\$	
1010	15086		S LATERAL CLEANOUT	10.00	EACH		\$	
1020	15087		S LATERAL LONG SIDE 04 INCH	5.00	EACH		\$	
1030	15088		S LATERAL LONG SIDE 06 INCH	2.00	EACH		\$	
1040	15093		S MANHOLE ABANDON/REMOVE	1.00	EACH		\$	
1050	15094		S MANHOLE ADJUST TO GRADE	8.00	EACH		\$	

Section: 0006 - DEMOBILIZATION &/OR MOBILIZATION

LINE	BID CODE	ALT	DESCRIPTION	QUANTITY	UNIT	UNIT PRIC	FP	AMOUNT
1060	02568		MOBILIZATION	1.00	LS		\$	
1070	02569		DEMOBILIZATION	1.00	LS		\$	