



**CALL NO. 300**

**CONTRACT ID. 191035**

**BULLITT COUNTY**

**FED/STATE PROJECT NUMBER FD04 015 0044 021-022**

**DESCRIPTION KY-44**

**WORK TYPE SLIDE REPAIR**

**PRIMARY COMPLETION DATE 12/15/2019**

**LETTING DATE: August 23,2019**

Sealed Bids will be received electronically through the Bid Express bidding service until 10:00 AM EASTERN DAYLIGHT TIME August 23,2019. Bids will be publicly announced at 10:00 AM EASTERN DAYLIGHT TIME.

**NO PLANS ASSOCIATED WITH THIS PROJECT.**

**REQUIRED BID PROPOSAL GUARANTY:** Not less than 5% of the total bid.

## TABLE OF CONTENTS

PART I	SCOPE OF WORK
	<ul style="list-style-type: none"><li>• PROJECT(S), COMPLETION DATE(S), &amp; LIQUIDATED DAMAGES</li><li>• CONTRACT NOTES</li><li>• STATE CONTRACT NOTES</li><li>• ASPHALT MIXTURE</li><li>• INCIDENTAL SURFACING</li><li>• COMPACTION OPTION B</li><li>• SPECIAL NOTE(S) APPLICABLE TO PROJECT</li><li>• TREE REMOVAL</li><li>• RIGHT OF WAY NOTES</li><li>• UTILITY IMPACT &amp; RAIL CERTIFICATION NOTES</li><li>• GENERAL UTILITY NOTES</li><li>• SEWER STANDARD UTILITY BID ITEMS</li><li>• SEWERLINE SPECS</li><li>• KPDES STORM WATER PERMIT, BMP AND ENOI</li></ul>
PART II	SPECIFICATIONS AND STANDARD DRAWINGS
	<ul style="list-style-type: none"><li>• SPECIFICATIONS REFERENCE</li><li>• SUPPLEMENTAL SPECIFICATION</li></ul>
PART III	EMPLOYMENT, WAGE AND RECORD REQUIREMENTS
	<ul style="list-style-type: none"><li>• LABOR AND WAGE REQUIREMENTS</li><li>• EXECUTIVE BRANCH CODE OF ETHICS</li><li>• KENTUCKY EQUAL EMPLOYMENT OPPORTUNITY ACT OF 1978 LOCALITY / STATE</li><li>• PROJECT WAGE RATES / STATE</li></ul>
PART IV	INSURANCE
PART V	BID ITEMS

**PART I**  
**SCOPE OF WORK**

## ADMINISTRATIVE DISTRICT - 05

**CONTRACT ID - 191035**

**FD04 015 0044 021-022**

**COUNTY - BULLITT**

**PCN - DE01500441935**

**FD04 015 0044 021-022**

KY-44 (MP 21.31) EMBANKMENT REPAIR ON KY-44 FROM MP 21.31 TO MP 21.36 IN BULLITT COUNTY (MP 21.36),  
A DISTANCE OF 0.05 MILES.SLIDE REPAIR

GEOGRAPHIC COORDINATES LATITUDE 37:57:00.00 LONGITUDE 85:40:00.00

**COMPLETION DATE(S):**

COMPLETED BY 12/15/2019

APPLIES TO ENTIRE CONTRACT

## **CONTRACT NOTES**

### **PROPOSAL ADDENDA**

All addenda to this proposal must be applied when calculating bid and certified in the bid packet submitted to the Kentucky Department of Highways. Failure to use the correct and most recent addenda may result in the bid being rejected.

### **BID SUBMITTAL**

Bidder must use the Department's electronic bidding software. The Bidder must download the bid file located on the Bid Express website ([www.bidx.com](http://www.bidx.com)) to prepare a bid packet for submission to the Department. The bidder must submit electronically using Bid Express.

### **JOINT VENTURE BIDDING**

Joint venture bidding is permissible. All companies in the joint venture must be prequalified in one of the work types in the Qualifications for Bidders for the project. The bidders must get a vendor ID for the joint venture from the Division of Construction Procurement and register the joint venture as a bidder on the project. Also, the joint venture must obtain a digital ID from Bid Express to submit a bid. A joint bid bond of 5% may be submitted for both companies or each company may submit a separate bond of 5%.

### **UNDERGROUND FACILITY DAMAGE PROTECTION**

The contractor shall make every effort to protect underground facilities from damage as prescribed in the Underground Facility Damage Protection Act of 1994, Kentucky Revised Statute KRS 367.4901 to 367.4917. It is the contractor's responsibility to determine and take steps necessary to be in compliance with federal and state damage prevention directives. When prescribed in said directives, the contractor shall submit Excavation Locate Requests to the Kentucky Contact Center (KY811) via web ticket entry. The submission of this request does not relieve the contractor from the responsibility of contacting non-member facility owners, whom shall be contacted through their individual Protection Notification Center. Non-compliance with these directives can result in the enforcement of penalties.

### **REGISTRATION WITH THE SECRETARY OF STATE BY A FOREIGN ENTITY**

Pursuant to KRS 176.085(1)(b), an agency, department, office, or political subdivision of the Commonwealth of Kentucky shall not award a state contract to a person that is a foreign entity required by [KRS 14A.9-010](#) to obtain a certificate of authority to transact business in the Commonwealth ("certificate") from the Secretary of State under [KRS 14A.9-030](#) unless the person produces the certificate within fourteen (14) days of the bid or proposal opening. If the foreign entity is not required to obtain a certificate as provided in [KRS 14A.9-010](#), the foreign entity should identify the applicable exception. Foreign entity is defined within [KRS 14A.1-070](#).

**For all foreign entities required to obtain a certificate of authority to transact business in the Commonwealth, if a copy of the certificate is not received by the contracting agency within the time frame identified above, the foreign entity's solicitation response shall be deemed non-responsive or the awarded contract shall be cancelled.**

Businesses can register with the Secretary of State at <https://secure.kentucky.gov/sos/ftbr/welcome.aspx>.

#### **SPECIAL NOTE FOR PROJECT QUESTIONS DURING ADVERTISEMENT**

Questions about projects during the advertisement should be submitted in writing to the Division of Construction Procurement. This may be done by fax (502) 564-7299 or email to [kytc.projectquestions@ky.gov](mailto:kytc.projectquestions@ky.gov). The Department will attempt to answer all submitted questions. The Department reserves the right not to answer if the question is not pertinent or does not aid in clarifying the project intent.

The deadline for posting answers will be 3:00 pm Eastern Daylight Time, the day preceding the Letting. Questions may be submitted until this deadline with the understanding that the later a question is submitted, the less likely an answer will be able to be provided.

The questions and answers will be posted for each Letting under the heading "Questions & Answers" on the Construction Procurement website ([www.transportation.ky.gov/contract](http://www.transportation.ky.gov/contract)). The answers provided shall be considered part of this Special Note and, in case of a discrepancy, will govern over all other bidding documents.

#### **HARDWOOD REMOVAL RESTRICTIONS**

The US Department of Agriculture has imposed a quarantine in Kentucky and several surrounding states, to prevent the spread of an invasive insect, the emerald ash borer. Hardwood cut in conjunction with the project may not be removed from the state. Chipping or burning on site is the preferred method of disposal.

#### **INSTRUCTIONS FOR EXCESS MATERIAL SITES AND BORROW SITES**

Identification of excess material sites and borrow sites shall be the responsibility of the Contractor. The Contractor shall be responsible for compliance with all applicable state and federal laws and may wish to consult with the US Fish and Wildlife Service to seek protection under Section 10 of the Endangered Species Act for these activities.

#### **ACCESS TO RECORDS**

The contractor, as defined in KRS 45A.030 (9) agrees that the contracting agency, the Finance and Administration Cabinet, the Auditor of Public Accounts, and the Legislative Research Commission, or their duly authorized representatives, shall have access to any books, documents, papers, records, or other evidence, which are directly pertinent to this contract for the purpose of financial audit or program review. Records and other prequalification information confidentially

disclosed as part of the bid process shall not be deemed as directly pertinent to the contract and shall be exempt from disclosure as provided in KRS 61.878(1)(c). The contractor also recognizes that any books, documents, papers, records, or other evidence, received during a financial audit or program review shall be subject to the Kentucky Open Records Act, KRS 61.870 to 61.884.

In the event of a dispute between the contractor and the contracting agency, Attorney General, or the Auditor of Public Accounts over documents that are eligible for production and review, the Finance and Administration Cabinet shall review the dispute and issue a determination, in accordance with Secretary's Order 11-004.

April 30, 2018

## **SPECIAL NOTE FOR RECIPROCAL PREFERENCE**

### **RECIPROCAL PREFERENCE TO BE GIVEN BY PUBLIC AGENCIES TO RESIDENT BIDDERS**

By reference, KRS 45A.490 to 45A.494 are incorporated herein and in compliance regarding the bidders residency. Bidders who want to claim resident bidder status should complete the Affidavit for Claiming Resident Bidder Status along with their bid in the electronic bidding software. Submittal of the Affidavit should be done along the bid in Bid Express.

April 30, 2018



### **ASPHALT MIXTURE**

Unless otherwise noted, the Department estimates the rate of application for all asphalt mixtures to be 110 lbs/sy per inch of depth.

### **INCIDENTAL SURFACING**

The Department has included in the quantities of asphalt mixtures established in the proposal estimated quantities required for resurfacing or surfacing mailbox turnouts, farm field entrances, residential and commercial entrances, curve widening, ramp gores and tapers, and road and street approaches, as applicable. Pave these areas to the limits as shown on Standard Drawing RPM-110-06 or as directed by the Engineer. In the event signal detectors are present in the intersecting streets or roads, pave the crossroads to the right of way limit or back of the signal detector, whichever is the farthest back of the mainline. Surface or resurface these areas as directed by the Engineer. The Department will not measure placing and compacting for separate payment but shall be incidental to the Contract unit price for the asphalt mixtures.

### **OPTION B**

Be advised that the Department will control and accept compaction of asphalt mixtures furnished on this project under OPTION B in accordance with Sections 402 and 403.

# BULLITT COUNTY

## KY 44 Embankment Repair

### 5-000.00

#### TABLE OF CONTENTS

DESCRIPTION	PAGE NO.
Project Location Map	2
Project Description	3
General Notes	4-5
Special Notes	6-9
Standard Drawings	10
Traffic Control Plan	11-15
Layout Sheet	16
Summary of Quantities/Typical Section	17
General & Temporary Traffic Control Notes	18
Plan & Profile	19
Right of Way Summary	20
Right of Way Strip Map	21
Modified Junction Box Detail Sheet	22
Pipe Drainage Sheet	23
Utility Relocation Plans (Sanitary Sewer)	24
Cross Sections	25-29

RECOMMENDED BY:  <hr style="width: 80%; margin-left: 0;"/> PROJECT MANAGER      DATE  PLAN APPROVED BY:  <hr style="width: 80%; margin-left: 0;"/> STATE HWY ENGINEER      DATE	PROPOSAL BY  KENTUCKY TRANSPORTATION CABINET  DEPARTMENT OF HIGHWAYS	PROPOSED TURN LANE EXTENSION  <table style="width: 100%; border-collapse: collapse;"> <tr> <td style="width: 50%; border-bottom: 1px solid black;"><u>ROUTE NAME:</u> KY 44</td> <td style="width: 50%; border-bottom: 1px solid black;"><u>LENGTH OF PROJECT:</u> 284.23 ft.</td> </tr> <tr> <td style="border-bottom: 1px solid black;"><u>COUNTY OF:</u> BULLITT</td> <td style="border-bottom: 1px solid black;"><u>STATE OF:</u> KENTUCKY</td> </tr> <tr> <td style="border-bottom: 1px solid black;"><u>MILE POINT:</u> 21.31 – 21.36</td> <td style="border-bottom: 1px solid black;"><u>ITEM NO.:</u> 5-000.00</td> </tr> <tr> <td></td> <td style="border-bottom: 1px solid black;"><u>SHEET NO.:</u> 1 of 29</td> </tr> </table>	<u>ROUTE NAME:</u> KY 44	<u>LENGTH OF PROJECT:</u> 284.23 ft.	<u>COUNTY OF:</u> BULLITT	<u>STATE OF:</u> KENTUCKY	<u>MILE POINT:</u> 21.31 – 21.36	<u>ITEM NO.:</u> 5-000.00		<u>SHEET NO.:</u> 1 of 29
<u>ROUTE NAME:</u> KY 44	<u>LENGTH OF PROJECT:</u> 284.23 ft.									
<u>COUNTY OF:</u> BULLITT	<u>STATE OF:</u> KENTUCKY									
<u>MILE POINT:</u> 21.31 – 21.36	<u>ITEM NO.:</u> 5-000.00									
	<u>SHEET NO.:</u> 1 of 29									

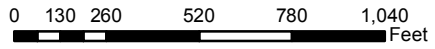
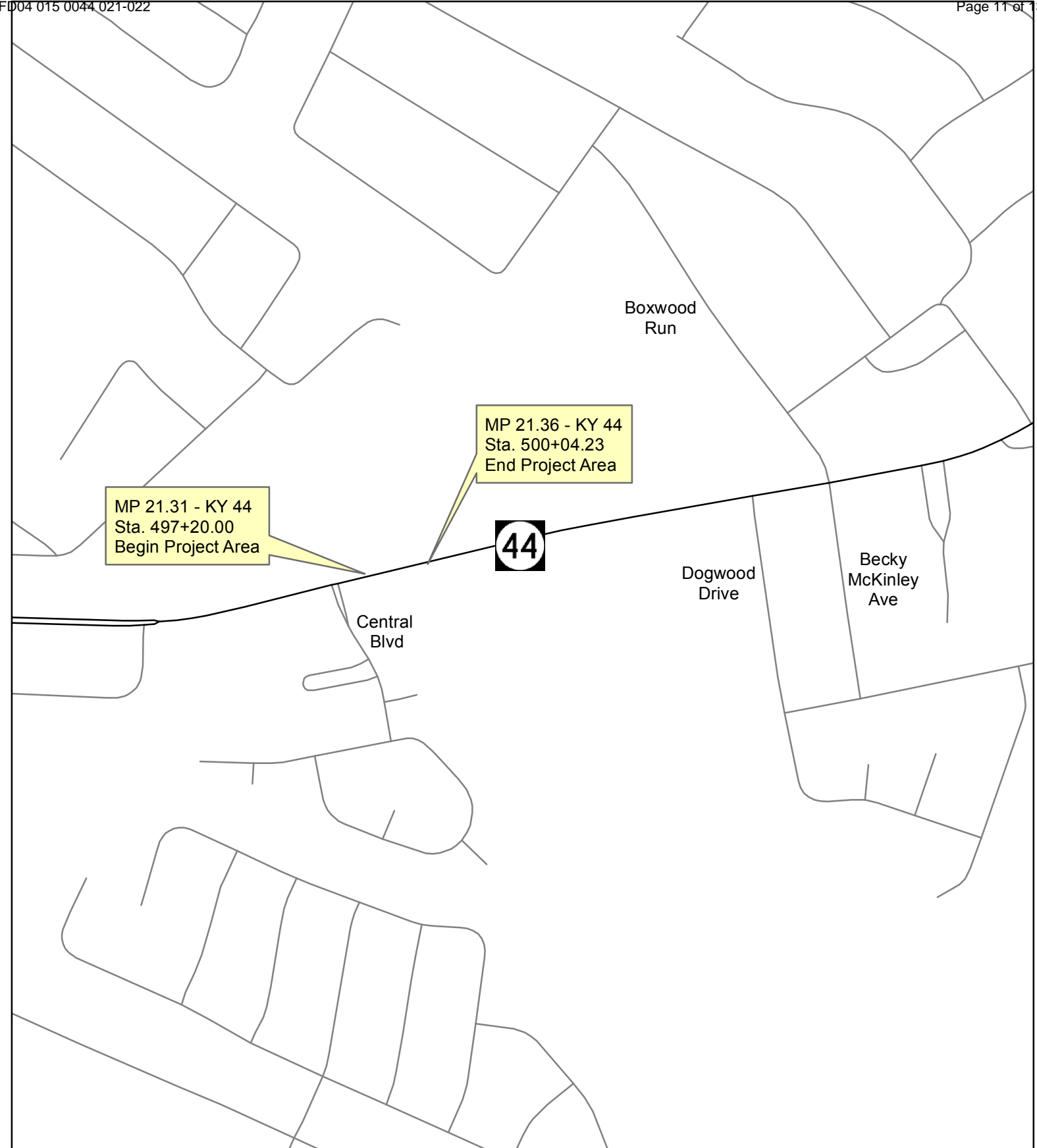

BULLITT COUNTY  
ITEM NO. 5-000.00  
EMBANKMENT REPAIR & DRAINAGE IMPROVEMENTS  
KY 44 (OLD MILL ROAD)

## **PROJECT DESCRIPTION**

Bullitt County  
Old Mill Road (KY 44) Embankment Repair

EMARS#9472801C  
Item No.  
N/A

### **SECTION ONE:**

The purpose of this project is to fix embankment issues currently experienced on the south side of Old Mill Road (KY 44) near Central Blvd. The project involves drainage improvements connecting to an existing 4' x 3' RCBC that outlets into a tributary to McCullough Run. The foreslopes of the embankment are proposed to be improved to where guardrail is no longer needed. Class II channel lining is proposed at the outlet of the proposed RCHEP headwall in the 8' flat bottom ditch as well as in the 2' flat bottom ditch where slopes are near 2:1. Turf reinforcement mat is proposed in the 2' flat bottom ditch accommodating flow from the 15" entrance pipe and special "v" ditch.

In addition, the following will also be required:

- Entrance pipe install and asphalt entrance repair for Parcel 2 according to plans.
- Full depth pavement repair according to limits shown on the plans.
- Replacement of existing dual drop box inlet grates to the north with Type I grates to improve positive drainage in the area due to repeated clogging issues.
- Sewer line relocation as shown in the utility relocation plans.
- Special attention should be made to LG&E provided notes for work near and around the existing active gas main. These notes are located on plan sheet R3.

## **GENERAL NOTES**

### **PROJECT COORDINATES:**

The coordinates for the center of the project are:

Northing: 38°2'15"N

Easting: 85°33'54"W

### **TRAFFIC VOLUME**

The ADT for this project was obtained from a Year 2016 computer estimate, and is as follows:

- 2016 ADT – 17,686

### **SURFACING AREAS**

Full depth pavement repair construction is estimated at 5 ft wide.

Total area to be surfaced is estimated to be 1,377 square feet.

The full depth shoulder construction is to be 1 ft wide.

Total shoulder area to be surfaced is estimated to be 162 square feet.

### **UNDERGROUND UTILITIES**

The contractor shall use all possible care in his operations to avoid damaging existing pipes and any underground existing utilities. He shall be responsible for any damages to the above mentioned items and shall repair or restore at his own expense any items damaged as the result of his operations. \* See LG&E provided notes on plan sheet R3

### **OVERHEAD UTILITIES**

The minimum vertical clearance of existing overhead utilities should be 18 feet on state roads and 24 feet when crossing interstate or other limited access highway roadways and ramps. Clearance must also adhere to the requirements of the National Electric Safety Code, American Standards Institute, and Institute of Electrical and Electronic Engineers, Inc. Any questions concerning working around the existing facilities in the area can be addressed at the preconstruction meeting.

### **UTILITIES (HAZARDOUS OR FLAMMABLE MATERIAL)**

The contractor is advised to exercise caution in his operations in areas of gas line or other lines carrying hazardous material. \* See LG&E provided notes on plan sheet R3

### **CONSTRUCTION MATERIAL DISPOSAL**

All pavement, asphalt material, and any other material that is required to be removed shall be disposed of off the Right-of-Way at sites acquired by the contractor and approved by the engineer, at no additional cost to the department, per section 204.03.08 of current KYTC Standard Specifications.

### **EXISTING SIGNS**

It is the contractor's responsibility to reset any signs inside the project limits that are affected by the project. This includes moving signs, adjusting the height, etc. This work will be directed by the engineer and considered incidental to the project.

### **AVOIDANCE OF UNDERGROUND TRAFFIC DEVICES (if applicable)**

It is the contractor's responsibility to coordinate with District Office traffic through the engineer to determine where underground traffic control devices are located for the project. Locations of existing traffic devices may not be accurately reflected on the plans and should be addressed before beginning construction. The contractor shall be responsible for any damages to the above mentioned items and shall repair or restore at their own expense any items damaged as a result of his operations.

### **OPTION B (if applicable)**

The Contractor is advised that the compaction of asphalt mixtures furnished to this project will be accepted by OPTION B in accordance with Section 402 and Section 403 of the current *Standard Specification*.

### **EROSION CONTROL**

The contractor and resident engineer shall develop the BMP according to section 213.03.01 of the Standard Specifications for Road and Bridge Construction, and the supplemental specs effective with the October, 2004 letting.

Erosion control measures shall be in place and functioning prior to any excavation or disturbance within a drainage area.

The contractor shall be required to clean out (remove sediment from) silt traps and silt fences whenever they become one-half full and properly dispose of the material at sites approved by the resident engineer.

Erosion control measures employed by the contractor will be unique to the project and work conditions and shall be approved by the resident engineer. The development and utilization of these measures will be recorded as part of the BMP, kept on site, and available for public inspection.

### **BEFORE YOU DIG**

THE CONTRACTOR IS INSTRUCTED TO CALL 1-800-752-6007 TO REACH KY 811, THE ONE-CALL SYSTEM FOR INFORMATION ON THE LOCATION OF EXISTING UNDERGROUND UTILITIES. THE CALL IS TO BE PLACED A MINIMUM OF TWO (2) AND NO MORE THAN TEN (10) BUSINESS DAYS PRIOR TO EXCAVATION. THE CONTRACTOR SHOULD BE AWARE THAT OWNERS OF UNDERGROUND FACILITIES ARE NOT REQUIRED TO BE MEMBERS OF THE KY 811 ONE-CALL BEFORE-U-DIG (BUD) SERVICE. THE CONTRACTOR MUST COORDINATE EXCAVATION WITH THE UTILITY OWNERS, INCLUDING THOSE WHOM DO NOT SUBSCRIBE TO KY 811. IT MAY BE NECESSARY FOR THE CONTRACTOR TO CONTACT THE COUNTY COURT CLERK TO DETERMINE WHAT UTILITY COMPANIES HAVE FACILITIES IN THE AREA.

***SPECIAL NOTE***

**For Tree Removal**

**Bullitt County  
KY-44 Embankment Repair  
Item No. n/a**

NO CLEARING OF TREES 5 INCHES OR GREATER  
(DIAMETER BREST HEIGHT) FROM JUNE 1 TO JULY 31.

**If there are any questions regarding this note, please contact  
Division of Environmental Analysis, 200 Mero Street, Frankfort, KY 40601,  
Phone: (502) 564-7250.**

## **SPECIAL NOTE FOR TURF REINFORCING MAT**

**1.0 DESCRIPTION.** Install turf reinforcement mat at locations specified in the Contract or as the Engineer directs. Section references herein are to the Department's 2012 Standard Specifications for Road and Bridge Construction.

### **2.0 MATERIALS.**

**2.1 Turf Reinforcement Mat (TRM).** Use a Turf Reinforcement Mat defined as permanent rolled erosion control product composed of non-degradable synthetic fibers, filaments, nets, wire mesh and/or other elements, processed into a three-dimensional matrix of sufficient thickness and from the Department's List of Approved Materials. Mats must be 100% UV stabilized materials. For TRMs containing degradable components, all physical property values must be obtained on the non-degradable portion of the matting exclusively. Ensure product labels clearly show the manufacturer or supplier name, style name, and roll number. Ensure labeling, shipment and storage follows ASTM D-4873. The Department will require manufacturer to provide TRMs that are machine constructed web of mechanically or melt bonded nondegradable fibers entangled to form a three dimensional matrix. The Department will require all long term performance property values in table below to be based on non degradable portion of the matting alone. Approved methods include polymer welding, thermal or polymer fusion, or placement of fibers between two high strength biaxially oriented nets mechanically bound by parallel stitching with polyolefin thread. Ensure that mats designated in the plans as Type 4 mats, are not to be manufactured from discontinuous or loosely held together by stitching or glued netting or composites. Type 4 mats shall be composed of geosynthetic matrix that exhibits a very high interlock and reinforcement capacities with both soil and root systems and with high tensile modulus. The Department will require manufacturer to use materials chemically and biologically inert to the natural soil environments conditions. Ensure the blanket is smolder resistant without the use of chemical additives. When stored, maintain the protective wrapping and elevate the mats off the ground to protect them from damage. The Department will not specify these materials for use in heavily acidic coal seam areas or other areas with soil problems that would severally limit vegetation growth.

- A) Dimensions. Ensure TRMs are furnished in strips with a minimum width of 4 feet and length of 50 feet.
- B) Weight. Ensure that all mat types have a minimum mass per unit area of 7 ounces per square yard according to ASTM D 6566.
- C) Performance Testing: The Department will require AASHTO's NTPEP index testing. The Department will also require the manufacturer to perform internal MARV testing at a Geosynthetic Accreditation Institute – Laboratory Accreditation Program (GAI-LAP) accredited laboratory for tensile strength, tensile elongation, mass per unit area, and thickness once every 24,000 yds of production or whatever rate is required to ensure 97.7% confidence under ASTM D4439& 4354. The Department will require Full scale testing for slope and channel applications shear stress shall be done under ASTM D 6459, ASTM D 6460-07 procedures.

### **2.2 Classifications**

The basis for selection of the type of mat required will be based on the long term shear stress level of the mat of the channel in question or the degree of slope to protect and will be designated in the contract. The Type 4 mats are to be used at structural backfills protecting critical



structures, utility cuts, areas where vehicles may be expected to traverse the mat, channels with large heavy drift, and where higher factors of safety, very steep slopes and/or durability concerns are needed as determined by project team and designer and will be specified in the plans by designer.

Turf Reinforcement Matting					
Properties <sup>1</sup>	Type 1	Type 2	Type 3	Type 4	Test Method
Minimum tensile Strength lbs/ft	125	150	175	3000 by 1500	ASTM D6818 <sup>2</sup>
UV stability (minimum % tensile retention)	80	80	80	90	ASTM D4355 <sup>3</sup> (1000-hr exposure)
Minimum thickness (inches)	0.25	0.25	0.25	0.40	ASTM D6525
Slopes applications	2H:1V or flatter	1.5H:1V or flatter	1H:1V or flatter	1 H: 1V or greater	
Shear stress lbs/ft <sup>2</sup> Channel applications	6.0 <sup>4</sup>	8.0 <sup>4</sup>	10.0 <sup>4</sup>	12.0 <sup>4</sup>	ASTM D6459 ASTM D6460-07

<sup>1</sup> For TRMs containing degradable components, all physical property values must be obtained on the non-degradable portion of the matting alone.

<sup>2</sup>Minimum Average Roll Values for tensile strength of sample material machine direction.

<sup>3</sup>Tensile Strength percentage retained after stated 1000 hr duration of exposure under ASTM D4355 testing. Based on nondegradable components exclusively.

<sup>4</sup>Maximum permissible shear design values based on short-term (0.5 hr) vegetated data obtained by full scale flume testing ASTM D6459, D6460-07. Based on nondegradable components exclusively. Testing will be done at Independent Hydraulics Facility such as Colorado State University hydraulics laboratory, Utah State University hydraulics laboratory, Texas Transportation Institute (TTI) hydraulics and erosion control laboratory.

### 2.3 Quality Assurance Sampling, Testing, and Acceptance

- A) Provide TRM listed on the Department’s List of Approved Materials. Prior to inclusion on the LAM, the manufacturer of TRM must meet the physical and performance criteria as outlined in the specification and submit a Letter Certifying compliance of the product under the above ASTM testing procedures and including a copy of report from Full Scale Independent Hydraulics Facility that Fully Vegetated Shear Stress meets shear stress requirements tested under D6459 and D6460-07.
- B) Contractors will provide a Letter of Certification from Manufacturer stating the product name, manufacturer, and that the product MARV product unit testing results meets Department criteria. Provide Letters once per project and for each product.
- C) Acceptance shall be in accordance with ASTM D-4759 based on testing performed by a Geosynthetic Accreditation Institute – Laboratory Accreditation Program (GAI-LAP) accredited laboratory using Procedure A of ASTM D-4354.

Current mats meeting the above criteria are shown on the Department’s List of Approved Materials.

**2.4 Fasteners.** When the mat manufacturer does not specify a specific fastener, use steel wire U-shaped staples with a minimum diameter of 0.09 inches (11 gauge), a minimum width of one inch and a minimum length of 12 inches. Use a heavier gauge when working in rocky or clay soils and longer lengths in sandy soils as directed by Engineer or Manufacturer’s Representative. Provide staples with colored tops when requested by the Engineer.

**3.0 CONSTRUCTION.** When requested by the Engineer, provide a Manufacturer’s Representative on-site to oversee and approve the initial installation of the mat. When requested by the Engineer, provide a letter from the Manufacturer approving the installation. When there is a conflict between the Department’s criteria and the Manufacturer’s criteria, construct using the more restrictive. The Engineer and Manufacturer’s Representative must approve all alternate installation methods prior to execution. Construct according to the Manufacturer’s recommendations and the following as minimum installation technique:

**3.1 Site Preparation.** Grade areas to be treated with matting and compact. Remove large rocks, soil clods, vegetation, roots, and other sharp objects that could keep the mat from intimate contact with subgrade. Prepare seedbed by loosening the top 2 to 3 inch of soil.

**3.2 Installation.** Install mats according to Standard Drawing Sepias “Turf Mat Channel Installation” and “Turf Mat Slope Installation.” Install mats at the specified elevation and alignment. Anchor the mats with staples with a minimum length of 12 inches. Use longer anchors for installations in sandy, loose, or wet soils as directed by the Engineer or Manufacturer’s Representative. The mat should be in direct contact with the soil surface.

**4.0 MEASUREMENT.** The Department will measure the quantity of Turf Reinforcement Mat by the square yard of surface covered. The Department will not measure preparation of the bed, providing a Manufacturer’s Representative, topsoil, or seeding for payment and will consider them incidental to the Turf Reinforcement Mat. The Department will not measure any reworking of slopes or channels for payment as it is considered corrective work and incidental to the Turf Reinforcement Mat. Seeding and protection will be an incidental item.

**5.0 PAYMENT.** The Department will make payment for the completed and accepted quantities under the following:

<u>Code</u>	<u>Pay Item</u>	<u>Pay Unit</u>
23274EN11F	Turf Reinforcement Mat 1	Square Yard
23275EN11F	Turf Reinforcement Mat 2	Square Yard
23276EN11F	Turf Reinforcement Mat 3	Square Yard
23277EN11F	Turf Reinforcement Mat 4	Square Yard

June 15, 2012

## STANDARD DRAWINGS

RDB-001-12	DROP BOX INLET TYPE 1
RDD-040-05	CHANNEL LINING CLASS II AND III
RDI-001-10	CULVERT, ENTRANCE & STORM SEWER PIPE TYPES & COVER HEIGHTS
RDI-011-03	CULVERT, ENTRANCE & STORM SEWER PIPE TYPES & COVER HEIGHTS
RDI-016-03	NON-CIRCULAR PIPE ALTERNATES
RDI-020-09	PIPE BEDDING FOR CULVERTS, ENTRANCE AND STORM SEWER PIPE
RDI-021-01	PIPE BEDDING FOR CULVERTS, ENTRANCE AND STORM SEWER REINFORCED CONC. PIPE
RDI-025-05	PIPE BEDDING TRENCH CONDITION
RDI-026-01	PIPE BEDDING TRENCH CONDITION REINFORCED CONC. PIPE
RDI-035-02	COATINGS, LININGS AND PAVINGS FOR NON-STRUCTURAL PLATE PIPE
RDI-040-01	EROSION CONTROL BLANKET SLOPE INSTALLATION
RDX-001-06	JUNCTION BOX
RDX-002-04	JUNCTION BOX (DIMENSIONS & QUANTITIES)
RDX-210-03	TEMPORARY SILT FENCE
RDX-215-01	TEMPORARY SILT FENCE WITH WOVEN WIRE FENCE FABRIC
RDX-220-05	SILT TRAP TYPE A
RDX-225-01	SILT TRAP TYPE B
RDX-230-01	SILT TRAP TYPE C
RPM-110-07	APPROACHES, ENTRANCES AND MAIL BOX TURNOUT
TTC-100-04	LANE CLOSURE TWO-LANE HIGHWAY
TTC-135-02	SHOULDER CLOSURE

## **TRAFFIC CONTROL PLAN**

One lane of traffic will remain open on KY 44 at all times. A lane closure is anticipated on KY 44 eastbound during full depth pavement repairs. The contractor is to utilize a single lane closure with a 10' minimum travel lane during this work. Lane closures will only be allowed during hours of low traffic volumes unless permission is otherwise granted by the engineer. Work along the roadside edge shall be signed for a right shoulder closure. All lane and shoulder closures shall be in conformance with the current MUTCD & KYTC Standard Drawings.

In addition, lane closures will not be allowed during the following days:

September 2<sup>nd</sup>, 2019 – Labor Day

November 11<sup>th</sup>, 2019 – Veterans Day

November 28<sup>th</sup>, 2019 – December 1<sup>st</sup>, 2019 – Thanksgiving Weekend

At the discretion of the Engineer, additional days and hours may be added when lane closures will not be allowed.

Night work is allowed on this project.

### **TRAFFIC CONTROL GENERAL:**

Except as provided herein, maintain and control traffic in accordance with the current Standard Specifications and Standard Drawings, current editions. Except for the roadway and traffic control bid items listed, all items of work necessary to maintain and control traffic will be paid at the lump sum bid price to “Maintain and Control Traffic.”

Contrary to Section 106.01, traffic control devices used on this project may be new or used in like-new condition, at the beginning of work and maintained in like new condition until completion of the work.

The speed limit in the work area may be reduced by 10 MPH from the posted speed. The extent of these areas within the project limits will be restricted to the proximity of actual work areas as determined by the engineer.

Traffic control devices should follow the MUTCD and the standard drawings and must be approved by the engineer before placement. Lane closures will include signing present in MUTCD TA-10. Shoulder work and work beyond the shoulder will include signing present in MUTCD TA-1, TA-3 or TA-6 when applicable. Signing is not limited to these guidelines and should be placed only with the approval from the engineer so as not to block sight distance. All lane closures shall be in conformance with the current MUTCD & KYTC Standard Drawings. The minimum clear lane width shall be 10 ft (this may include a portion of the adjacent shoulder). If traffic should be stopped due to construction operations and a school bus or emergency vehicle on an official run arrives on the scene, make provisions for the passage of the bus as quickly as possible.

At the discretion of the engineer, additional days and hours may be specified when lane closures will not be allowed.

Once work begins at a site, promptly complete all work at that site. Maintain at least one access point to each parcel at all times. Keep the traveled way clear of mud and debris at all times during construction. Do not allow non-construction equipment, vehicles, or office trailers at work sites. Leave the right of way clear of all equipment, materials, and vehicles during non-working hours.

Take these restrictions into account when preparing bid. The Department will not consider any claims or allow additional payment for any delays to the Contractor as a result of these restrictions.

### **PROJECT PHASING AND CONSTRUCTION PROCEDURES:**

Traffic shall utilize existing lanes. Work along the roadside edge shall be signed for a right shoulder closure. Refer to Std. Dwg. TTC-135 "Shoulder Closure" for applicable signs, cones and placement. Pavement repair work shall be signed for a single lane closure during hours of low traffic volumes. Refer to Std. Dwg. TTC-100-04 "Lane Closure Two-Lane Highway" for applicable signs, cones and placement. The speed limit shall be reduced to 35 MPH in the work zone. 35 MPH signs (W13-1P) shall be installed Eastbound with sign W21-5b (see detail example on R2A).

If embankment grading along the shoulder edge will not allow for a two lane traveled way with minimum lane widths of 10 feet, utilize a single lane closure during hours of low traffic volumes. Refer top Std. Dwg. TTC-100-04 "Lane Closure Two-Lane Highway" for applicable signs, drums and placement.

Note: The existing guardrail shall not be removed until embankment grading is completed or the contractor has foreslopes at a 3:1 or flatter from the shoulder. Slopes steeper that 3:1 are proposed in certain areas where embankment fill height is minimal and a barrier is not required. See cross sections for slopes.

Lane closures will only be allowed during hours of low traffic volume unless permission is otherwise given by the engineer.

#### Hours of Low Traffic Volume

**Monday - Friday**      9:00 A.M. – 2:30 P.M.  
                                 8:00 P.M. – 6:00 A.M.

**Weekends**              8:00 P.M. Friday – 6:00 A.M. Monday

The specified completion date for this project is **December 15<sup>th</sup>, 2019**.

### **PROJECT DISCRETION:**

Refer to Section 108.09 of the current edition of the KENTUCKY STANDARD SPECIFICATIONS FOR ROAD CONSTRUCTION for the schedule of agreed liquidated damages should construction continue beyond the specified completion date.

In addition, Contrary to Section 108.09, Liquidated Damages shall be assessed for the following:

The contractor shall work in a continuous manner once temporary traffic control is in place. If the contractor stops work in an area for more than two calendar days, without the engineers approval, the liquidated damages will be assessed at the contract rate for every day until work resumes.

**LANE CLOSURES:**

Do not leave lane closures in place during non-working hours.

**SIGNS:**

The engineer may require additional traffic control signs in addition to normal lane closure signing detailed on the Standard Drawings.

Replacements for damaged signs directed by the engineer to be replaced due to poor condition or reflectivity will not be measured for payment.

**BARRICADES:**

Barricades used in lieu of barrels and cones for channelization or delineation shall be incidental to Maintain and Control Traffic according to Section 112.04.01. Barricades used to protect pavement removal areas will be paid as each according to Section 112.04.04.

**VARIABLE MESSAGE SIGNS:**

If deemed necessary by the engineer, variable message signs will be installed, operated and maintained by the Department.

**TRAFFIC COORDINATOR:**

Designate an employee to be traffic coordinator during any work period when shoulder and/or lane closure is in place, the traffic coordinator shall arrange for personnel to be present on the project at all times to inspect the traffic control (at least once every two hours during active operations and at any time a lane closure is in effect) and to maintain the signing and devices. The personnel shall have access to on the project to a radio or telephone to be used in case of emergencies or accidents. The traffic coordinator shall report all incidents throughout the work zone to the engineer. Furnish the engineer with the name and telephone number where the traffic coordinator can be contacted at all times.

**PAVEMENT EDGE DROP-OFFS:**

Pavement edge drop offs must be designated with channelizing devices (warning light optional) every 15' or eliminated with a DGA taper at the end of each work period.

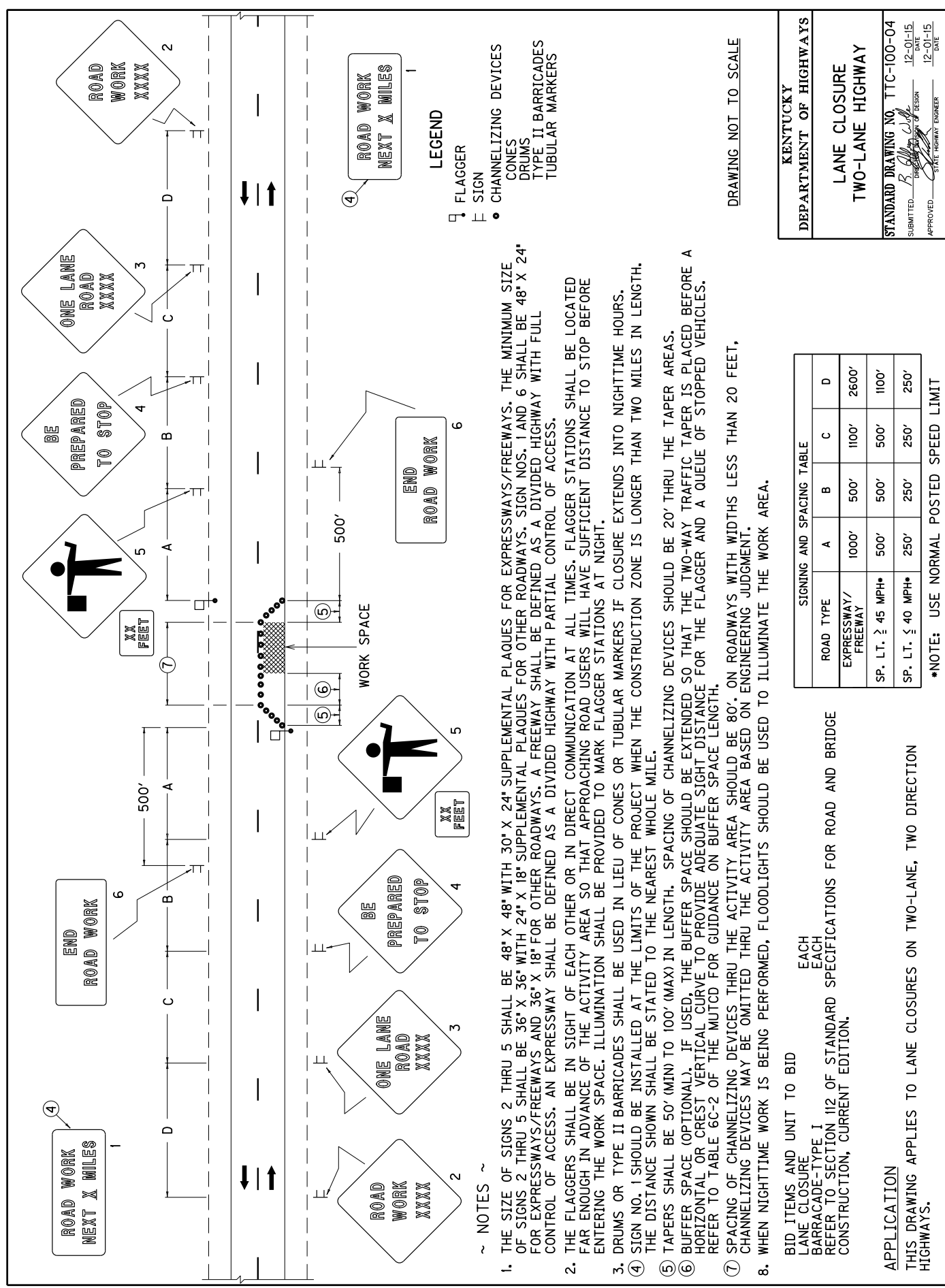

~ NOTES ~

1. THE SIZE OF SIGNS 2 THRU 5 SHALL BE 48" X 48" WITH 30" X 24" SUPPLEMENTAL PLAQUES FOR EXPRESSWAYS/FREEWAYS. THE MINIMUM SIZE OF SIGNS 2 THRU 5 SHALL BE 36" X 36" WITH 24" X 18" SUPPLEMENTAL PLAQUES FOR OTHER ROADWAYS. SIGN NOS. 1 AND 6 SHALL BE 48" X 24" FOR EXPRESSWAYS/FREEWAYS AND 36" X 18" FOR OTHER ROADWAYS. A FREEWAY SHALL BE DEFINED AS A DIVIDED HIGHWAY WITH FULL CONTROL OF ACCESS. AN EXPRESSWAY SHALL BE DEFINED AS A DIVIDED HIGHWAY WITH PARTIAL CONTROL OF ACCESS.
2. THE FLAGGERS SHALL BE IN SIGHT OF EACH OTHER OR IN DIRECT COMMUNICATION AT ALL TIMES. FLAGGER STATIONS SHALL BE LOCATED FAR ENOUGH IN ADVANCE OF THE ACTIVITY AREA SO THAT APPROACHING ROAD USERS WILL HAVE SUFFICIENT DISTANCE TO STOP BEFORE ENTERING THE WORK SPACE. ILLUMINATION SHALL BE PROVIDED TO MARK FLAGGER STATIONS AT NIGHT.
3. DRUMS OR TYPE II BARRICADES SHALL BE USED IN LIEU OF CONES OR TUBULAR MARKERS IF CLOSURE EXTENDS INTO NIGHTTIME HOURS.
4. SIGN NO. 1 SHOULD BE INSTALLED AT THE LIMITS OF THE PROJECT WHEN THE CONSTRUCTION ZONE IS LONGER THAN TWO MILES IN LENGTH. THE DISTANCE SHOWN SHALL BE STATED TO THE NEAREST WHOLE MILE.
5. TAPERS SHALL BE 50' (MIN) TO 100' (MAX) IN LENGTH. SPACING OF CHANNELIZING DEVICES SHOULD BE 20' THRU THE TAPER AREAS.
6. BUFFER SPACE (OPTIONAL). IF USED, THE BUFFER SPACE SHOULD BE EXTENDED SO THAT THE TWO-WAY TRAFFIC TAPER IS PLACED BEFORE A HORIZONTAL OR CREST VERTICAL CURVE TO PROVIDE ADEQUATE SIGHT DISTANCE FOR THE FLAGGER AND A QUEUE OF STOPPED VEHICLES. REFER TO TABLE 6C-2 OF THE MUTCD FOR GUIDANCE ON BUFFER SPACE LENGTH.
7. SPACING OF CHANNELIZING DEVICES THRU THE ACTIVITY AREA SHOULD BE 80'. ON ROADWAYS WITH WIDTHS LESS THAN 20 FEET, CHANNELIZING DEVICES MAY BE OMITTED THRU THE ACTIVITY AREA BASED ON ENGINEERING JUDGMENT.
8. WHEN NIGHTTIME WORK IS BEING PERFORMED, FLOODLIGHTS SHOULD BE USED TO ILLUMINATE THE WORK AREA.

BID ITEMS AND UNIT TO BID  
 EACH  
 LANE CLOSURE  
 EACH  
 BARRICADE-TYPE I  
 REFER TO SECTION 112 OF STANDARD SPECIFICATIONS FOR ROAD AND BRIDGE  
 CONSTRUCTION, CURRENT EDITION.

SIGNING AND SPACING TABLE				
ROAD TYPE	A	B	C	D
EXPRESSWAY/ FREEWAY	1000'	500'	1100'	2600'
SP. LT. ≥ 45 MPH*	500'	500'	500'	1100'
SP. LT. ≤ 40 MPH*	250'	250'	250'	250'

\*NOTE: USE NORMAL POSTED SPEED LIMIT

APPLICATION

THIS DRAWING APPLIES TO LANE CLOSURES ON TWO-LANE, TWO DIRECTION HIGHWAYS.

**KENTUCKY**  
**DEPARTMENT OF HIGHWAYS**

**LANE CLOSURE**  
**TWO-LANE HIGHWAY**

STANDARD DRAWING NO. TTC-100-04  
 SUBMITTED: *B. Allen* DATE: 12-01-15  
 DESIGNED BY: *B. Allen* DATE: 12-01-15  
 APPROVED: \_\_\_\_\_ DATE: 12-01-15  
STATE HIGHWAY ENGINEER

DRAWING NOT TO SCALE

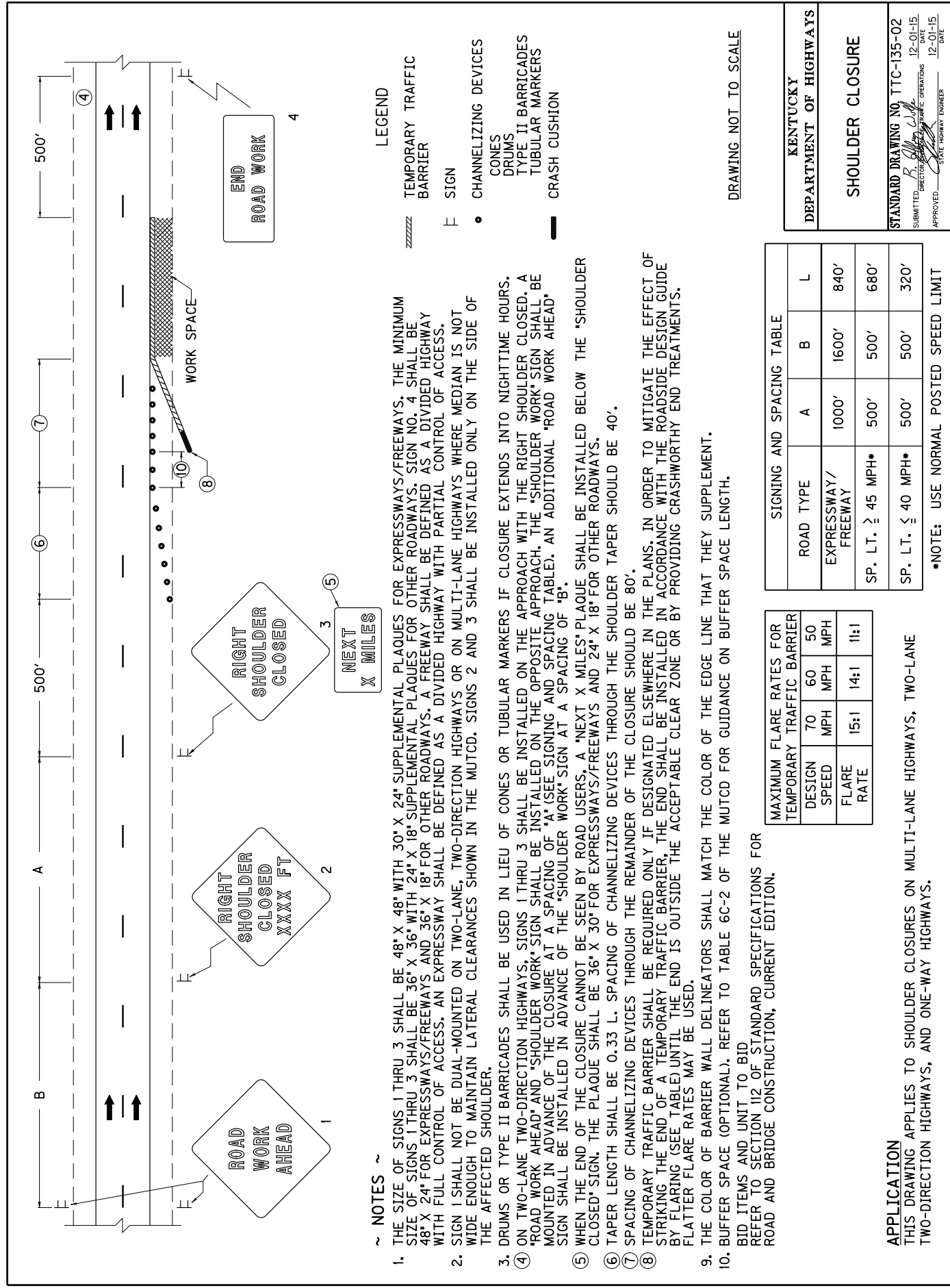

~ NOTES ~

1. THE SIZE OF SIGNS 1 THRU 3 SHALL BE 48" X 48" WITH 30" X 24" SUPPLEMENTAL PLAQUES FOR EXPRESSWAYS/FREEWAYS. THE MINIMUM SIZE OF SIGNS 1 THRU 3 SHALL BE 36" X 36" WITH 24" X 18" SUPPLEMENTAL PLAQUES FOR OTHER ROADWAYS. SIGN NO. 4 SHALL BE 48" X 24" FOR EXPRESSWAYS/FREEWAYS AND 36" X 18" FOR OTHER ROADWAYS. A FREEWAY SHALL BE DEFINED AS A DIVIDED HIGHWAY WITH FULL CONTROL OF ACCESS. AN EXPRESSWAY SHALL BE DEFINED AS A DIVIDED HIGHWAY WITH PARTIAL CONTROL OF ACCESS.
2. SIGN 1 SHALL NOT BE DUAL-MOUNTED ON TWO-LANE, TWO-DIRECTION HIGHWAYS OR ON MULTI-LANE HIGHWAYS WHERE MEDIAN IS NOT WIDE ENOUGH TO MAINTAIN LATERAL CLEARANCES SHOWN IN THE MUTCD. SIGNS 2 AND 3 SHALL BE INSTALLED ONLY ON THE SIDE OF THE AFFECTED SHOULDER.
3. DRUMS OR TYPE II BARRICADES SHALL BE USED IN LIEU OF CONES OR TUBULAR MARKERS IF CLOSURE EXTENDS INTO NIGHTTIME HOURS.
4. ON TWO-LANE TWO-DIRECTION HIGHWAYS, SIGNS 1 THRU 3 SHALL BE INSTALLED ON THE APPROACH WITH THE RIGHT SHOULDER CLOSED. A "ROAD WORK AHEAD" AND "SHOULDER WORK" SIGN SHALL BE INSTALLED ON THE OPPOSITE APPROACH. THE "SHOULDER WORK" SIGN SHALL BE MOUNTED IN ADVANCE OF THE CLOSURE AT A SPACING OF "A" (SEE SIGNING AND SPACING TABLE). AN ADDITIONAL "ROAD WORK AHEAD" SIGN SHALL BE INSTALLED IN ADVANCE OF THE "SHOULDER WORK" SIGN AT A SPACING OF "B".
5. WHEN THE END OF THE CLOSURE CANNOT BE SEEN BY ROAD USERS, A "NEXT X MILES" PLAQUE SHALL BE INSTALLED BELOW THE "SHOULDER CLOSED" SIGN. THE PLAQUE SHALL BE 36" X 30" FOR EXPRESSWAYS/FREEWAYS AND 24" X 18" FOR OTHER ROADWAYS.
6. TAPER LENGTH SHALL BE 0.33 L. SPACING OF CHANNELIZING DEVICES THROUGH THE SHOULDER TAPER SHOULD BE 40'.
7. SPACING OF CHANNELIZING DEVICES THROUGH THE REMAINDER OF THE CLOSURE SHOULD BE 80'.
8. TEMPORARY TRAFFIC BARRIER SHALL BE REQUIRED ONLY IF DESIGNATED ELSEWHERE IN THE PLANS. IN ORDER TO MITIGATE THE EFFECT OF STRIKING THE END OF A TEMPORARY TRAFFIC BARRIER, THE END SHALL BE INSTALLED IN ACCORDANCE WITH THE ROADSIDE DESIGN GUIDE BY FLARING (SEE TABLE) UNTIL THE END IS OUTSIDE THE ACCEPTABLE CLEAR ZONE OR BY PROVIDING CRASHWORTHY END TREATMENTS. FLATTER FLARE RATES MAY BE USED.
9. THE COLOR OF BARRIER WALL DELINEATORS SHALL MATCH THE COLOR OF THE EDGE LINE THAT THEY SUPPLEMENT.
10. BUFFER SPACE (OPTIONAL). REFER TO TABLE 6C-2 OF THE MUTCD FOR GUIDANCE ON BUFFER SPACE LENGTH.

BID ITEMS AND UNIT TO BID  
REFER TO SECTION 112 OF STANDARD SPECIFICATIONS FOR ROAD AND BRIDGE CONSTRUCTION, CURRENT EDITION.

DRAWING NOT TO SCALE

MAXIMUM FLARE RATES FOR TEMPORARY TRAFFIC BARRIER		
DESIGN SPEED	70 MPH	60 MPH
FLARE RATE	15:1	14:1

SIGNING AND SPACING TABLE			
ROAD TYPE	A	B	L
EXPRESSWAY/FREEWAY	1000'	1600'	840'
SP. LT. ≥ 45 MPH*	500'	500'	680'
SP. LT. ≤ 40 MPH*	500'	500'	320'

\*NOTE: USE NORMAL POSTED SPEED LIMIT

APPLICATION  
THIS DRAWING APPLIES TO SHOULDER CLOSURES ON MULTI-LANE HIGHWAYS, TWO-LANE TWO-DIRECTION HIGHWAYS, AND ONE-WAY HIGHWAYS.

**KENTUCKY**  
**DEPARTMENT OF HIGHWAYS**

**SHOULDER CLOSURE**

STANDARD DRAWING NO. TTC-135-02  
SUBMITTED BY: *R. Allen Clark*  
DIRECTOR OF TRAFFIC OPERATIONS  
APPROVED BY: *[Signature]*  
STATE HIGHWAY ENGINEER  
DATE: 12-01-15



COUNTY OF	BULLITT	ITEM NO.	5-000.00	SHEET	022
				OF	101

# Commonwealth of Kentucky DEPARTMENT OF HIGHWAYS

## PLANS OF PROPOSED PROJECT BULLITT COUNTY OLD MILL ROAD (KY 44) EMBANKMENT REPAIR & DRAINAGE IMPROVEMENTS FD04 015 0044 021-022



INDEX OF SHEETS	
SHEET NO.	DESCRIPTION
R1	LAYOUT SHEET
R2	PLAN AND PROFILE SUMMARY OF QUANTITIES
R3	RIGHT OF WAY SUMMARY SHEETS
R4	MODIFIED JUNCTION BOX DETAIL SHEET
R5	PIPE DRAINAGE SHEETS
U1	UTILITY RELOCATION PLANS (SANITARY, SEWER)
X1-45	CROSS SECTION SHEETS

STANDARD DRAWINGS	
NUMBER	DESCRIPTION
800-001-12	ADT PRESENT (1, 2016) 17.686
800-001-13	ADT FUTURE (1, 2016) 17.686
800-001-14	DIV. 1, 640
800-001-15	DIV. 1, 7, 572
800-001-16	DIV. 1, 7, 572
800-001-17	DIV. 1, 7, 572
800-001-18	DIV. 1, 7, 572
800-001-19	DIV. 1, 7, 572
800-001-20	DIV. 1, 7, 572
800-001-21	DIV. 1, 7, 572
800-001-22	DIV. 1, 7, 572
800-001-23	DIV. 1, 7, 572
800-001-24	DIV. 1, 7, 572
800-001-25	DIV. 1, 7, 572
800-001-26	DIV. 1, 7, 572
800-001-27	DIV. 1, 7, 572
800-001-28	DIV. 1, 7, 572
800-001-29	DIV. 1, 7, 572
800-001-30	DIV. 1, 7, 572
800-001-31	DIV. 1, 7, 572
800-001-32	DIV. 1, 7, 572
800-001-33	DIV. 1, 7, 572
800-001-34	DIV. 1, 7, 572
800-001-35	DIV. 1, 7, 572
800-001-36	DIV. 1, 7, 572
800-001-37	DIV. 1, 7, 572
800-001-38	DIV. 1, 7, 572
800-001-39	DIV. 1, 7, 572
800-001-40	DIV. 1, 7, 572
800-001-41	DIV. 1, 7, 572
800-001-42	DIV. 1, 7, 572
800-001-43	DIV. 1, 7, 572
800-001-44	DIV. 1, 7, 572
800-001-45	DIV. 1, 7, 572
800-001-46	DIV. 1, 7, 572
800-001-47	DIV. 1, 7, 572
800-001-48	DIV. 1, 7, 572
800-001-49	DIV. 1, 7, 572
800-001-50	DIV. 1, 7, 572
800-001-51	DIV. 1, 7, 572
800-001-52	DIV. 1, 7, 572
800-001-53	DIV. 1, 7, 572
800-001-54	DIV. 1, 7, 572
800-001-55	DIV. 1, 7, 572
800-001-56	DIV. 1, 7, 572
800-001-57	DIV. 1, 7, 572
800-001-58	DIV. 1, 7, 572
800-001-59	DIV. 1, 7, 572
800-001-60	DIV. 1, 7, 572
800-001-61	DIV. 1, 7, 572
800-001-62	DIV. 1, 7, 572
800-001-63	DIV. 1, 7, 572
800-001-64	DIV. 1, 7, 572
800-001-65	DIV. 1, 7, 572
800-001-66	DIV. 1, 7, 572
800-001-67	DIV. 1, 7, 572
800-001-68	DIV. 1, 7, 572
800-001-69	DIV. 1, 7, 572
800-001-70	DIV. 1, 7, 572
800-001-71	DIV. 1, 7, 572
800-001-72	DIV. 1, 7, 572
800-001-73	DIV. 1, 7, 572
800-001-74	DIV. 1, 7, 572
800-001-75	DIV. 1, 7, 572
800-001-76	DIV. 1, 7, 572
800-001-77	DIV. 1, 7, 572
800-001-78	DIV. 1, 7, 572
800-001-79	DIV. 1, 7, 572
800-001-80	DIV. 1, 7, 572
800-001-81	DIV. 1, 7, 572
800-001-82	DIV. 1, 7, 572
800-001-83	DIV. 1, 7, 572
800-001-84	DIV. 1, 7, 572
800-001-85	DIV. 1, 7, 572
800-001-86	DIV. 1, 7, 572
800-001-87	DIV. 1, 7, 572
800-001-88	DIV. 1, 7, 572
800-001-89	DIV. 1, 7, 572
800-001-90	DIV. 1, 7, 572
800-001-91	DIV. 1, 7, 572
800-001-92	DIV. 1, 7, 572
800-001-93	DIV. 1, 7, 572
800-001-94	DIV. 1, 7, 572
800-001-95	DIV. 1, 7, 572
800-001-96	DIV. 1, 7, 572
800-001-97	DIV. 1, 7, 572
800-001-98	DIV. 1, 7, 572
800-001-99	DIV. 1, 7, 572
800-001-100	DIV. 1, 7, 572



### LAYOUT MAP

THIS PROJECT IS OFF THE NH SYSTEM

DESIGN CRITERIA	
CLASS OF HIGHWAY	URBAN ARTERIAL
TYPE OF TERRAIN	ROLLING
DESIGN SPEED	55
REQUIRED PAVEMENT	495
REQUIRED PCSI	1985
LEVEL OF SERVICE	
ADT PRESENT (1, 2016)	17,686
ADT FUTURE (1, 2016)	
DIV.	1, 640
D %	
T %	7, 572
F %	7, 572

GEOGRAPHIC COORDINATES	
LATITUDE	38 DEGREES 2 MINUTES 16 SECONDS NORTH
LONGITUDE	85 DEGREES 32 MINUTES 54 SECONDS WEST
<b>DESIGNED</b>	
% RESTRICTED SO	
LEVEL OF SERVICE	
MAX. DISTANCE W/O PASSING	

LENGTH	284.23	UN. FT.	0.554	MILES	LENGTH	UN. FT.	MILES	LENGTH	UN. FT.	MILES	LENGTH	UN. FT.	MILES
FOR EQUALITIES INCLUDED					FOR EQUALITIES INCLUDED			FOR EQUALITIES INCLUDED			FOR EQUALITIES INCLUDED		
FOR EQUALITIES NOT INCLUDED					FOR EQUALITIES NOT INCLUDED			FOR EQUALITIES NOT INCLUDED			FOR EQUALITIES NOT INCLUDED		
RAILROAD CROSSINGS NO.					RAILROAD CROSSINGS NO.			RAILROAD CROSSINGS NO.			RAILROAD CROSSINGS NO.		
BRIDGES					BRIDGES			BRIDGES			BRIDGES		

**Commonwealth of Kentucky  
DEPARTMENT OF HIGHWAYS  
COUNTY OF  
BULLITT**

ITEM NO. 5-000.00  
PROJECT NUMBER: FD04 015 0044 021-022  
LETTING DATE: \_\_\_\_\_  
RECOMMENDED BY: \_\_\_\_\_ PROJECT MANAGER: \_\_\_\_\_ DATE: \_\_\_\_\_  
DISTRICT 5 DESIGN  
PLAN APPROVED BY: \_\_\_\_\_ STATE PROJECT ENGINEER: \_\_\_\_\_ DATE: \_\_\_\_\_



COUNTY OF	ITEM NO.	SHEET
BULLITT	5-000.00	022

**GENERAL SUMMARY**

ITEM	DESCRIPTION	UNIT	OLD MILL RD	TOTAL PROJECT
440	ENTRANCE PIPE - 15 IN	LF	134	134
489	CULVERT PIPE - 48 IN EQUIV	LF	37	37
1217	PIPE CULVERT HEADWALL-48 IN EQUIV	EA	1	1
1310	REMOVE PIPE	EA	63	63
1650	JUNCTION BOX	EA	1	1
2014	BARRICADE-TYPE III	EA	2	2
2159	TEMP DITCH	LF	140	140
2230	EMBANKMENT IN PLACE	CY	802	802
2381	REMOVE GUARDRAIL	CY	250	250
2403	REMOVE CONCRETE MASONRY	CY	1	1
2483	CHANNEL LINING CLASS II	TON	59	59
2645	CLEARING AND CRIBBING	LS	1	1
2562	TEMPORARY SIGNS	SP	106	106
2569	DEMOLITIZATION	LS	1	1
2585	EDGE KEY	LF	12	12
2596	FABRIC-GEOTEXTILE TYPE I	SY	93	93
2599	FABRIC-GEOTEXTILE TYPE IV	SY	144	144
2600	FABRIC-GEOTEXTILE TYPE IV FOR PIPE	SY	342	342
2625	REMOVE HEADWALL	EA	1	1
2650	MAINTAIN AND CONTROL TRAFFIC	LS	1	1
2701	TEMPORARY SILT FENCE	LF	336	336
2703	SILT TRAP TYPE A	EA	1	1
2704	SILT TRAP TYPE B	EA	3	3
2705	SILT TRAP TYPE C	EA	4	4
2706	CLEAN SILT TRAP TYPE A	EA	1	1
2707	CLEAN SILT TRAP TYPE B	EA	3	3
2708	CLEAN SILT TRAP TYPE C	EA	4	4
2726	STAKING	LS	1	1
5950	EROSION CONTROL BLANKET	TON	600	600
5963	INITIAL FERTILIZER	TON	.01	.01
5964	20-10-10 FERTILIZER	TON	.05	.05
5985	SEEDING AND PROTECTION	SY	1,000	1,000
5982	AGRICULTURAL LIMESTONE	TON	.62	.62
6514	PAVE STRIPING-PERMI PAINT-4 IN	LF	800	800
2128BD	LONGITUDINAL EDGE KEY	EA	160	160
20366N	REPLACE GRATE	EA	2	2
23274ENIF	TURF REINFORCEMENT MAT I	SY	28	28

**PAVING SUMMARY**

ITEM CODE	ITEM	UNIT	OLD MILL RD	TOTAL PROJECT
3	CRUSHED STONE BASE	TONS	29	38
78	CRUSHED AGGREGATE NO. 2 (ROCK ROADBED)	TONS	75	75
214	CL3 ASPH BASE 1.000 PG64-22	TONS	83	86
22906ES403	CL3 ASPH SURF 0.38A PG64-22	TONS	9	2
356	ASPHALT MATERIAL FOR TACK	TONS	.15	.16

**PAVING AREAS**

ITEM	UNIT	OLD MILL RD	TOTAL PROJECT
CRUSHED STONE BASE	TONS	125	152
CRUSHED AGGREGATE NO. 2 (ROCK ROADBED)	TONS	125	125
CL3 ASPH BASE 1.000 PG64-22	TONS	116	143
CL3 ASPH SURF 0.38A PG64-22	TONS	126	153
ASPHALT MATERIAL FOR TACK	TONS	126	153

**NOTES**

- ALL ASPHALT MIXTURES SHALL BE ESTIMATED AT 140 LBS PER SQ. YD. PER INCH OF DEPTH, UNLESS NOTED OTHERWISE.
- ESTIMATED AT 115 LBS. PER SQ. YD. PER INCH OF DEPTH.
- ESTIMATED AT 100 LBS. PER SQ. YD. PER INCH OF DEPTH.
- ESTIMATED AT 95 LBS. PER SQ. YD. PER INCH OF DEPTH.
- ESTIMATED AT 0.84 LBS PER SQ. YD.
- EXCAVATION AND PAVEMENT REMOVAL IS INCIDENTAL TO EMBANKMENT IN PLACE.
- INCLUDES EASEMENT AREAS, AND REMOVAL OF ALL UNSUITABLE MATERIAL AS THE ENGINEER DIRECTS. APPROX. 0.27 ACRE.
- PAVEMENT SAWCUT IS INCIDENTAL TO LONGITUDINAL EDGE KEY.
- REPLACE WITH TYPE I GRATE. NEEDED TO MINIMIZE CLOGGING. TO BE APPROVED BY THE ENGINEER.
- AFTER REMOVAL, GUARDRAIL IS TO BE HAULED AND STORED AT THE BULLITT COUNTY MAINTENANCE FACILITY.
- FOR SLOPES STEEPER THAN 4:1
- FOR USE UNDER CHANNEL LINING CLASS II

EMBANKMENT	801.60 CU YD TOTAL EMB.
EXCAVATION	141.05 CU YD TOTAL EXC.

ESTIMATE FOR EARTHWORK CALCULATIONS FOR DESIGN AND INFORMATION ONLY. ASSUMPTIONS FOR SHRINKAGE AND SWELL FACTORS ARE THE CONTRACTORS RESPONSIBILITY.

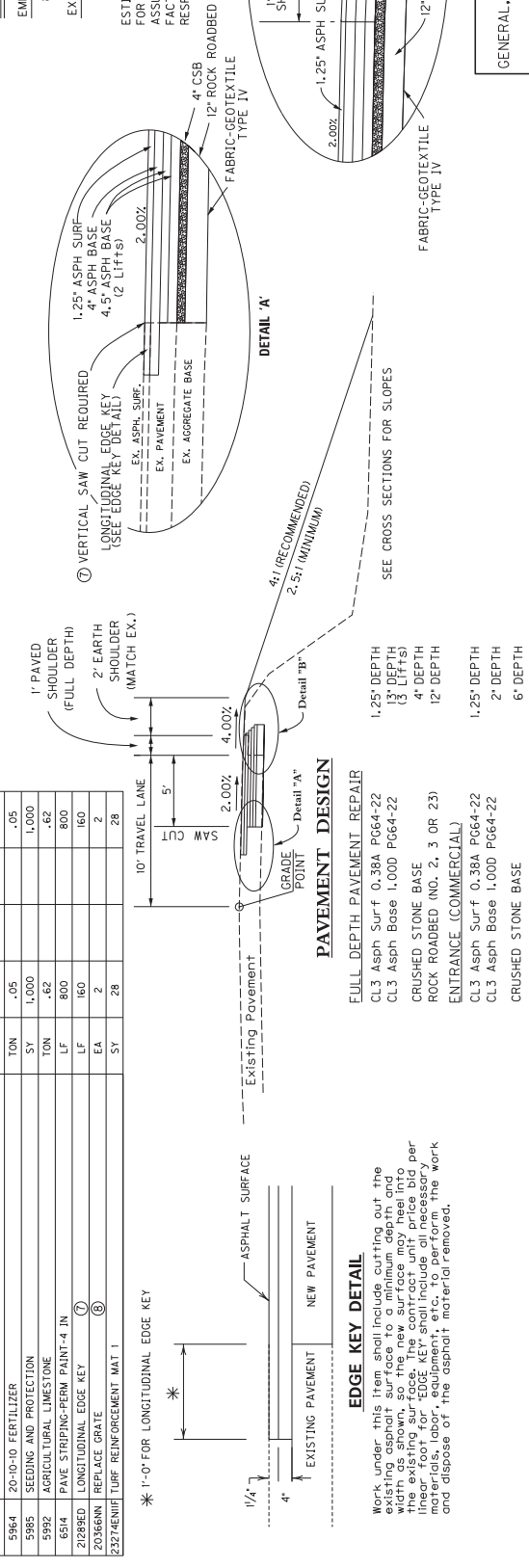







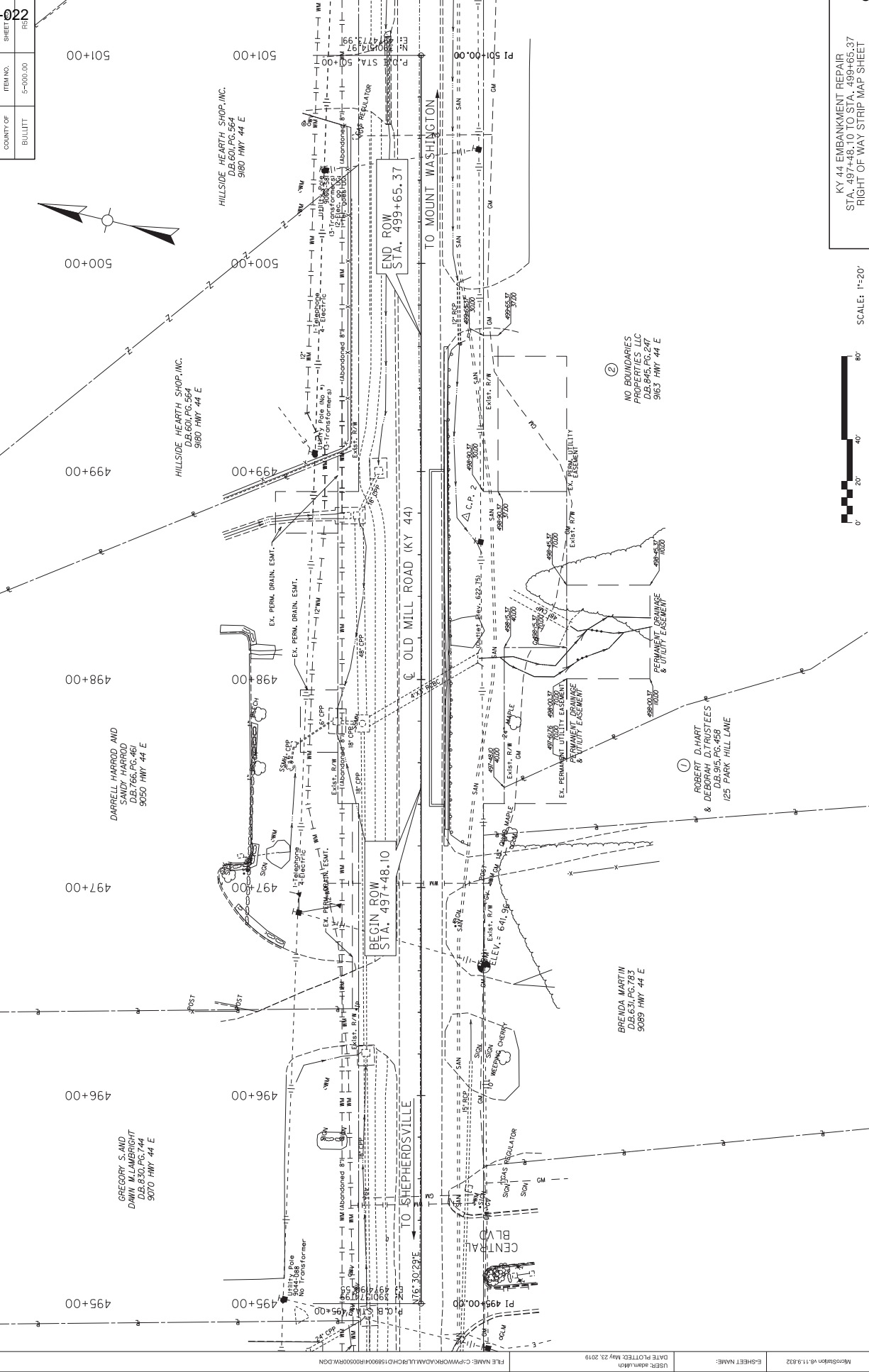

SHEET NO.	5-000.00
BULLITT COUNTY	

495+00  
 496+00  
 497+00  
 498+00  
 499+00  
 500+00  
 501+00

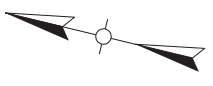

SCALE: 1"=20'

KY 44 EMBANKMENT REPAIR  
 STA. 497+48.10 TO STA. 499+65.37  
 RIGHT OF WAY STRIP MAP SHEET

DRAWING SCALE:  
SCALE: 1/5"=1'-0"

~ NOTES ~

- BID ITEM AND UNIT TO BID  
EACH  
JUNCTION BOX
1. THE CONTRACT UNIT PRICE EACH SHALL INCLUDE PAYMENT IN FULL FOR ALL MATERIALS, EXCAVATION, LABOR AND INCIDENTALS NECESSARY TO COMPLETE THE WORK.
  2. STEEL REINFORCEMENT IN THE TOP AND BOTTOM SHALL BE NO. 5 BARS PLACED 6" O.C. STEEL REINFORCEMENT IN THE SIDEWALL SHALL BE NO. 4 BARS PLACED 5" O.C.
  3. THE BOX FROM FINAL GRADE TO FLOW LINE OF THE PIPE HAS BEEN SPECIFICALLY DESIGNED FOR A DEPTH OF 17'-5".
  4. SEE THIS SHEET FOR DIMENSIONS AND QUANTITIES.
  5. TO ELIMINATE FORM REMOVAL, THE TOP SHALL BE PRECAST.
  6. QUANTITY DEDUCTIONS HAVE BEEN MADE FOR PIPE AND CULVERT.
  7. REMOVE EXISTING CULVERT PARAPET. CLEAN AND EXPOSE EXISTING CULVERT PARAPET REINFORCEMENT AND INCORPORATE IT INTO THE NEW CONCRETE.
  8. DRILL AND EPOXY DOWELS INTO EXISTING SIDEWALLS AND BOTTOM SLAB OF CULVERT. DOWELS SHALL BE NO. 5 BARS PLACED 6" O.C.

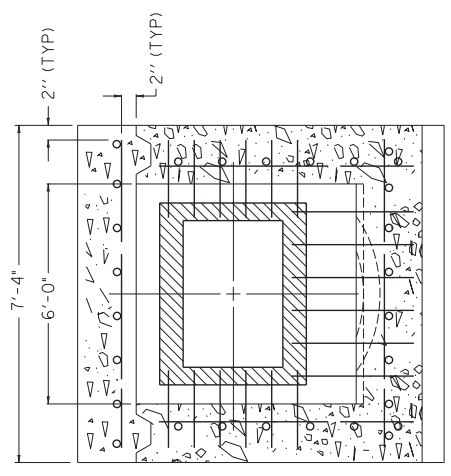
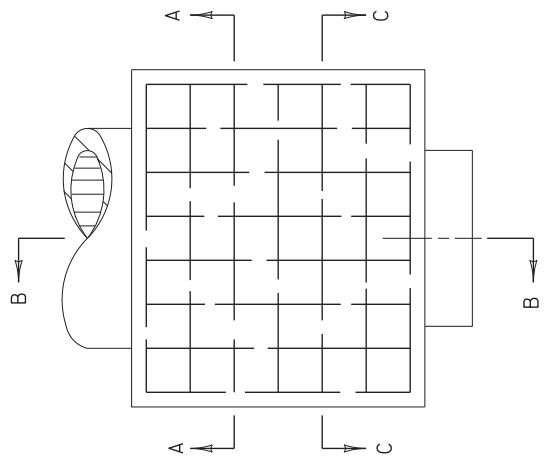

SECTION C-C

ESTIMATE OF QUANTITIES:  
CONCRETE = 4.7 CUBIC YARDS  
REINF. STEEL = 797 LBS

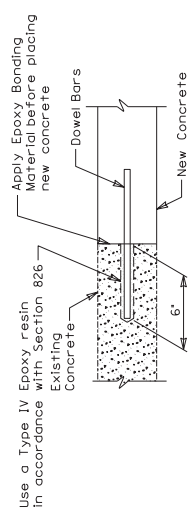

DOWEL DETAILS

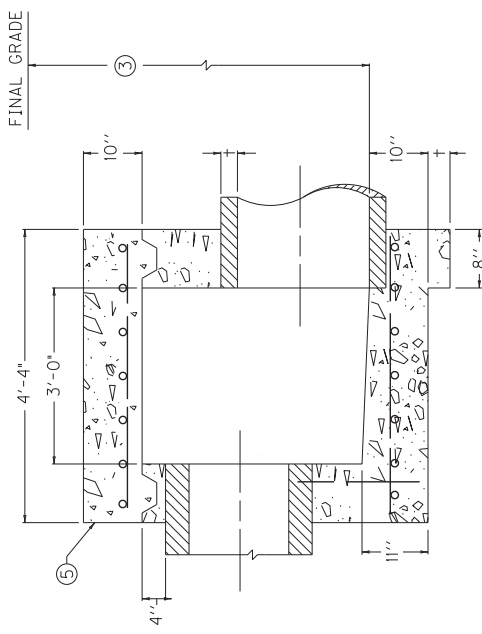

SECTION B-B

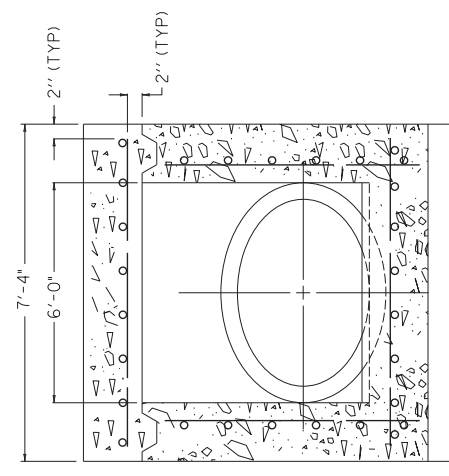

SECTION A-A

KENTUCKY  
DEPARTMENT OF HIGHWAYS  
MODIFIED JUNCTION BOX

DATE: 1-3-97  
DRAWN: D.H. MCALISTER  
CHECKED: D.H. MCALISTER  
RECOMMENDED: 6-97  
APPROVED: F.H.W. A.

METRIC R.O.M. FEB. 14, 1994  
ENGLISH DHM 12-11-98  
UPDATED: J. LALL 6-2015







SHEET NO.	COUNTY OF	ITEM NO.	ROCK		EMB.	COM	GRAN. EMB.	REFILL	ROCK BED	ROCK EXC	DT LT	DT RT
			BULLITT	EXC								
XL		5-000.00										

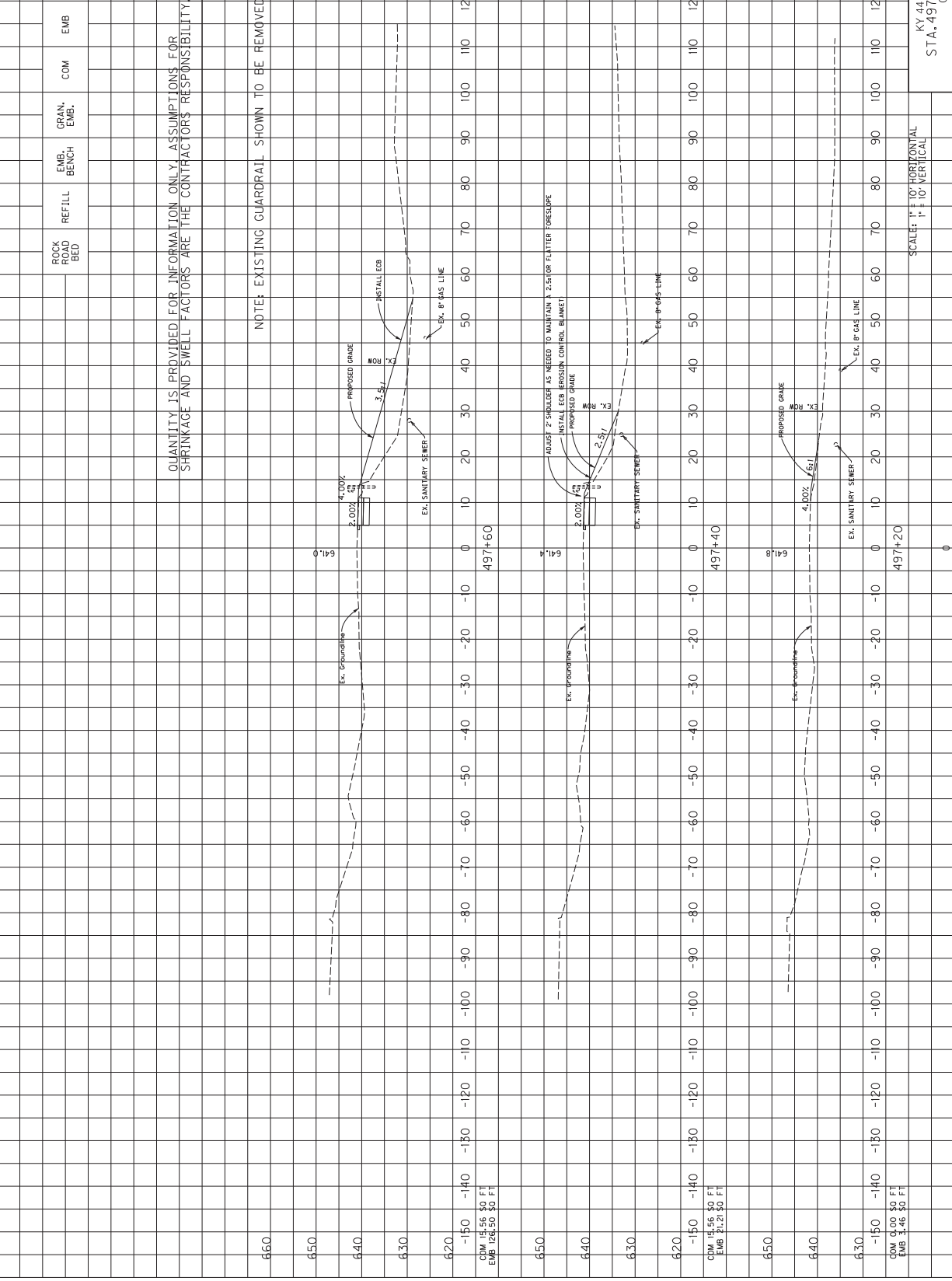

QUANTITY IS PROVIDED FOR INFORMATION ONLY. ASSUMPTIONS FOR SHRINKAGE AND SWELL FACTORS ARE THE CONTRACTOR'S RESPONSIBILITY.

NOTE: EXISTING GUARDRAIL SHOWN TO BE REMOVED

SCALE: 1" = 10' HORIZONTAL  
1" = 10' VERTICAL

KY 44 EMBANKMENT REPAIR  
STA. 497+20 TO STA. 497+60  
CROSS SECTIONS

660												
650												
640												
630												
620												
615	15.56	30 FT										
610	126.50	50 FT										
650												
640												
630												
620												
615	15.56	30 FT										
610	126.50	50 FT										
650												
640												
630												
620												
615	15.56	30 FT										
610	126.50	50 FT										

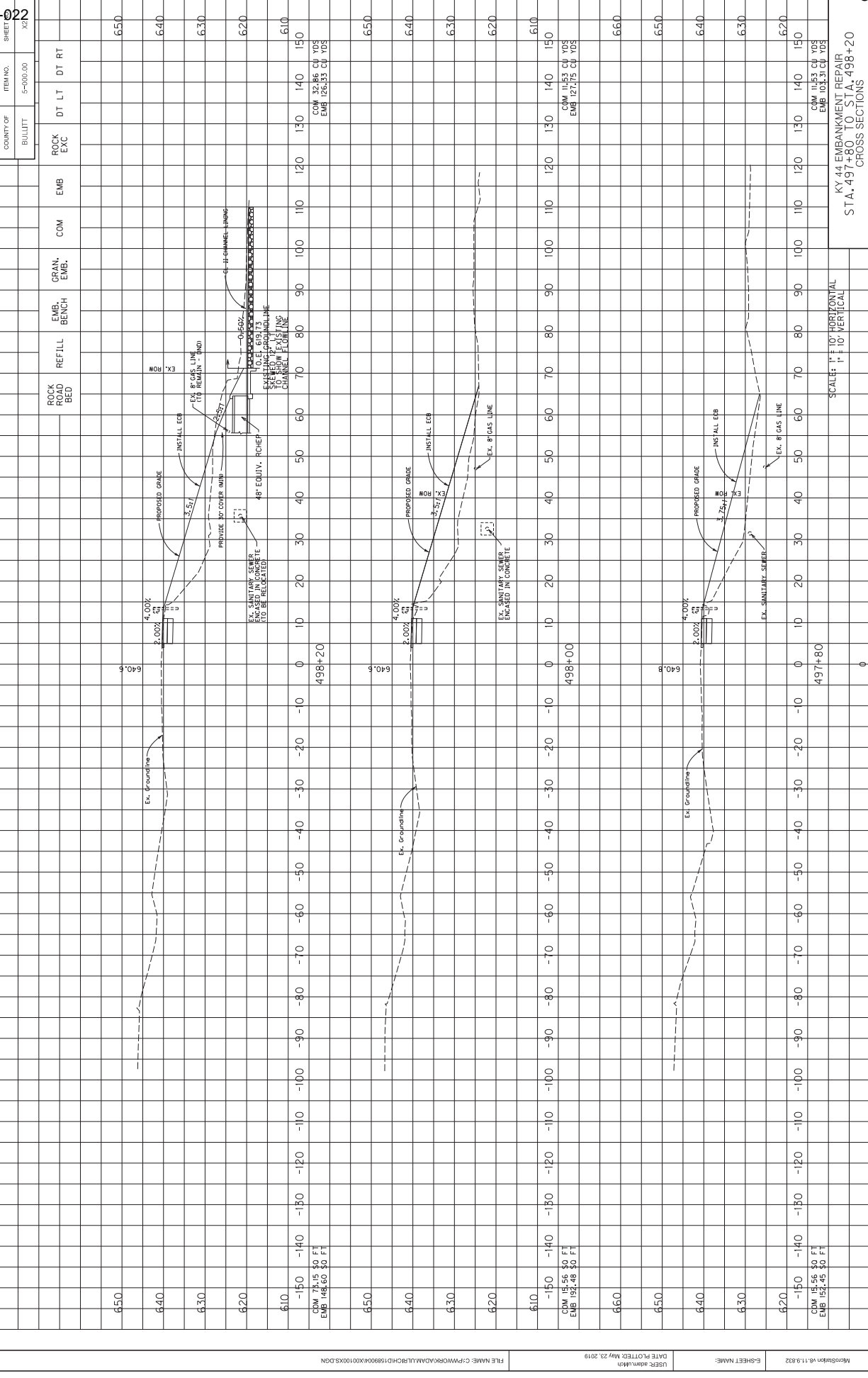

ITEM NO.	COUNTY OF	ITEM NO.	SHEET
5-000.00	BULLITT	5-000.00	22

ROCK BED	REFILL	EMB. BENCH	GRAN. EMB.	COM	EMB	ROCK EXC	DT LT	DT RT
650								
640								
630								
620								
610								
150							140	150
CDM 148.56 30 FT							COM 32.86 CU YDS	
EMB 148.60 50 FT							EMB 126.33 CU YDS	
650								
640								
630								
620								
610								
150							140	150
CDM 151.56 30 FT							COM 11.53 CU YDS	
EMB 152.48 50 FT							EMB 127.75 CU YDS	
660								
650								
640								
630								
620								
150							140	150
CDM 151.56 30 FT							COM 11.53 CU YDS	
EMB 152.45 50 FT							EMB 103.31 CU YDS	

SCALE: 1" = 10' HORIZONTAL  
1" = 10' VERTICAL

KY 44 EMBANKMENT REPAIR  
STA. 497+80 TO STA. 498+20  
CROSS SECTIONS

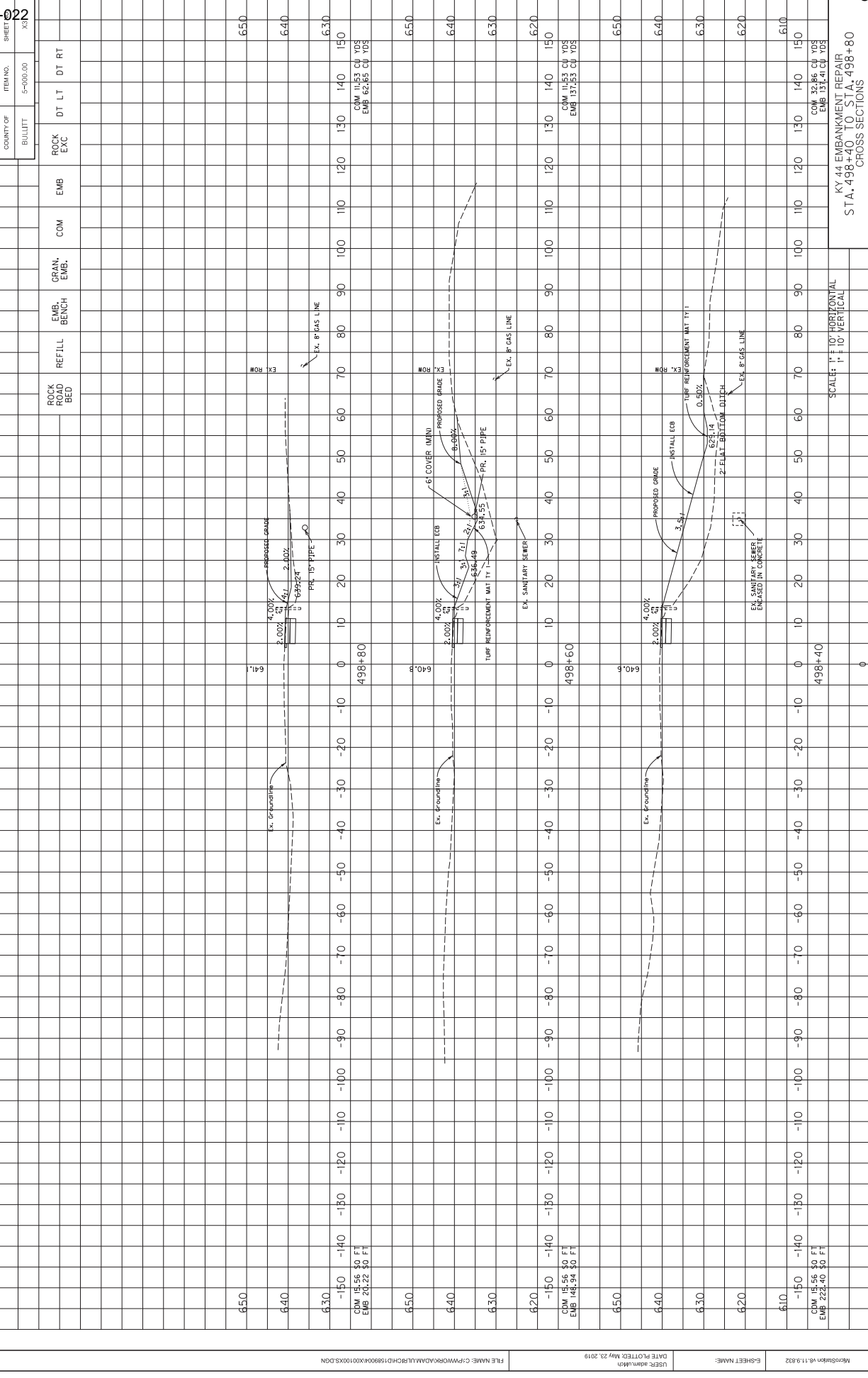

ITEM NO.	COUNTY OF	SHEET
5-000.00	BULLITT	33

ITEM NO.	DESCRIPTION	QUANTITY	UNIT	PRICE	TOTAL
11.53	CU YDS	11.53	CU YDS		11.53
62.85	CU YDS	62.85	CU YDS		62.85
137.53	CU YDS	137.53	CU YDS		137.53
11.53	CU YDS	11.53	CU YDS		11.53
32.86	CU YDS	32.86	CU YDS		32.86
137.41	CU YDS	137.41	CU YDS		137.41

ITEM NO.	DESCRIPTION	QUANTITY	UNIT	PRICE	TOTAL
11.53	CU YDS	11.53	CU YDS		11.53
62.86	CU YDS	62.86	CU YDS		62.86
137.53	CU YDS	137.53	CU YDS		137.53

ITEM NO.	DESCRIPTION	QUANTITY	UNIT	PRICE	TOTAL
11.53	CU YDS	11.53	CU YDS		11.53
32.86	CU YDS	32.86	CU YDS		32.86
137.41	CU YDS	137.41	CU YDS		137.41

ITEM NO.	DESCRIPTION	QUANTITY	UNIT	PRICE	TOTAL
11.53	CU YDS	11.53	CU YDS		11.53
32.86	CU YDS	32.86	CU YDS		32.86
137.41	CU YDS	137.41	CU YDS		137.41

  

ITEM NO.	DESCRIPTION	QUANTITY	UNIT	PRICE	TOTAL
11.53	CU YDS	11.53	CU YDS		11.53
32.86	CU YDS	32.86	CU YDS		32.86
137.41	CU YDS	137.41	CU YDS		137.41

Scale: 1" = 10' HORIZONTAL  
1" = 1' VERTICAL

KY 44 EMBANKMENT REPAIR  
STA. 498+40 TO STA. 498+80  
CROSS SECTIONS



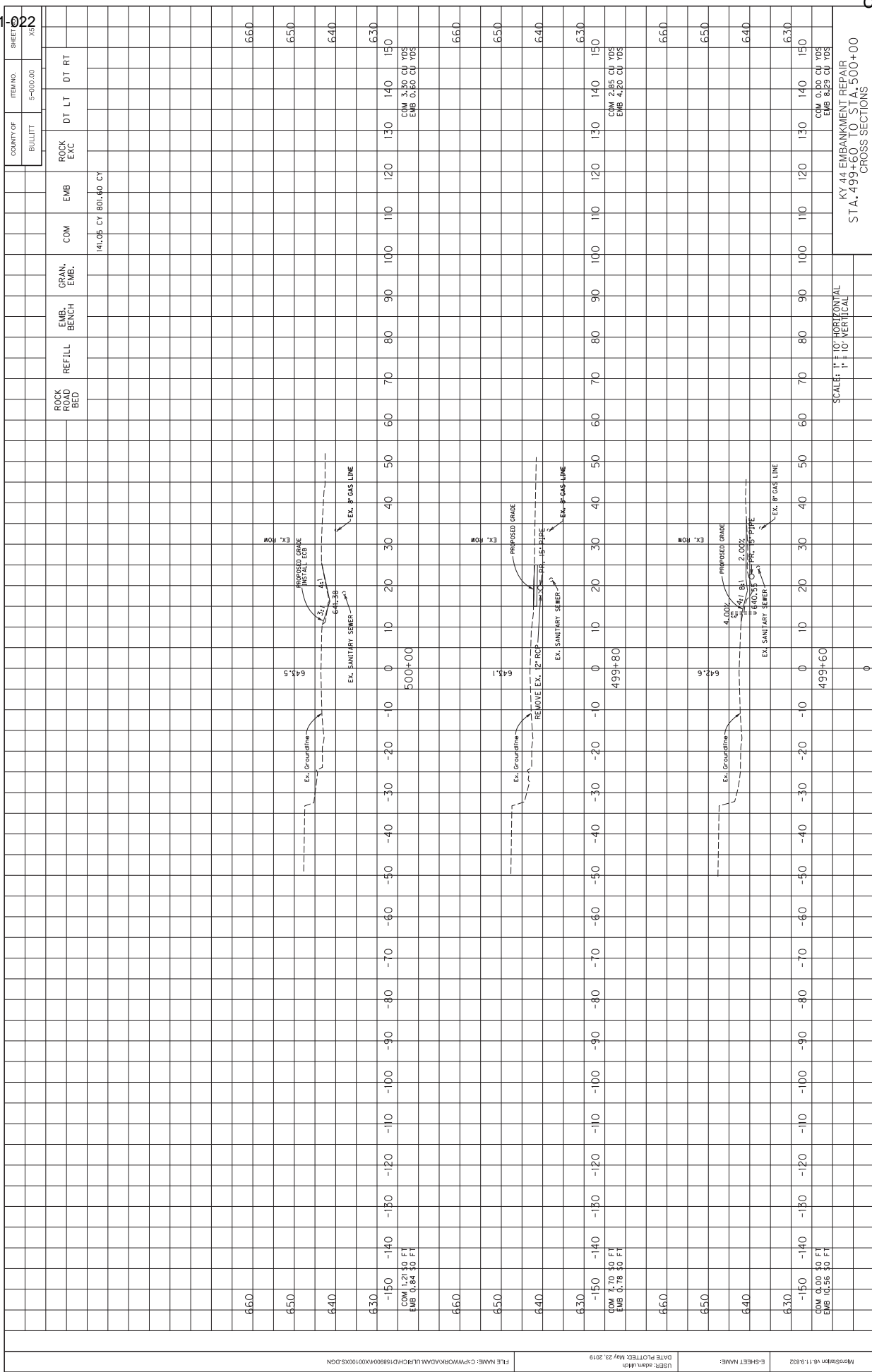

ITEM NO.	COUNTY OF	SHEET
5-000.00	BULLITT	38

ITEM NO.	DESCRIPTION	QUANTITY	UNIT
660	COM 2.85 CU YDS	141.05	CY
650	EMB 4.80 CU YDS	801.60	CY
640	COM 3.30 CU YDS		
630	EMB 0.80 CU YDS		

STATION	ROCK BED	REFILL	EMB. BENCH	GRAN. EMB.	COM	EMB	DT	LT	DT	RT
500+00										
499+80										

STATION	COM	EMB
-150	1.70 CU YDS	0.78 CU YDS
-140	1.21 CU YDS	0.84 CU YDS
499+60	0.00 CU YDS	0.56 CU YDS

SCALE: 1" = 10' HORIZONTAL  
1" = 10' VERTICAL

KY 44 EMBANKMENT REPAIR  
STA. 499+60 TO STA. 500+00  
CROSS SECTIONS

***SPECIAL NOTE***

**For Tree Removal**

**Bullitt County  
KY-44 Embankment Repair  
Item No. n/a**

NO CLEARING OF TREES 5 INCHES OR GREATER  
(DIAMETER BREST HEIGHT) FROM JUNE 1 TO JULY 31.



**If there are any questions regarding this note, please contact  
Division of Environmental Analysis, 200 Mero Street, Frankfort, KY 40601,  
Phone: (502) 564-7250.**



KENTUCKY TRANSPORTATION CABINET  
Department of Highways  
**DIVISION OF RIGHT OF WAY & UTILITIES**

**RIGHT OF WAY CERTIFICATION**

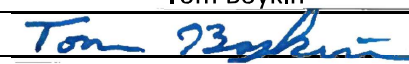
TC 62-226  
Rev. 01/2016  
Page 1 of 1

<input checked="" type="checkbox"/>	<b>Original</b>	<input type="checkbox"/>	<b>Re-Certification</b>	<b>RIGHT OF WAY CERTIFICATION</b>			
<b>ITEM #</b>		<b>COUNTY</b>		<b>PROJECT # (STATE)</b>		<b>PROJECT # (FEDERAL)</b>	
5-452.00		Bullitt		1100 FD04 015 9472801R			
<b>PROJECT DESCRIPTION</b>							
repair slide on KY 44 0.052 mile east of Central Blvd (MP 21.328)							
<input type="checkbox"/> <b>No Additional Right of Way Required</b>							
Construction will be within the limits of the existing right of way. The right of way was acquired in accordance to FHWA regulations under the Uniform Relocation Assistance and Real Property Acquisitions Policy Act of 1970, as amended. No additional right of way or relocation assistance were required for this project.							
<input checked="" type="checkbox"/> <b>Condition # 1 (Additional Right of Way Required and Cleared)</b>							
All necessary right of way, including control of access rights when applicable, have been acquired including legal and physical possession. Trial or appeal of cases may be pending in court but legal possession has been obtained. There may be some improvements remaining on the right-of-way, but all occupants have vacated the lands and improvements, and KYTC has physical possession and the rights to remove, salvage, or demolish all improvements and enter on all land. Just Compensation has been paid or deposited with the court. All relocations have been relocated to decent, safe, and sanitary housing or that KYTC has made available to displaced persons adequate replacement housing in accordance with the provisions of the current FHWA directive.							
<input type="checkbox"/> <b>Condition # 2 (Additional Right of Way Required with Exception)</b>							
The right of way has not been fully acquired, the right to occupy and to use all rights-of-way required for the proper execution of the project has been acquired. Some parcels may be pending in court and on other parcels full legal possession has not been obtained, but right of entry has been obtained, the occupants of all lands and improvements have vacated, and KYTC has physical possession and right to remove, salvage, or demolish all improvements. Just Compensation has been paid or deposited with the court for most parcels. Just Compensation for all pending parcels will be paid or deposited with the court prior to AWARD of construction contract							
<input type="checkbox"/> <b>Condition # 3 (Additional Right of Way Required with Exception)</b>							
The acquisition or right of occupancy and use of a few remaining parcels are not complete and/or some parcels still have occupants. All remaining occupants have had replacement housing made available to them in accordance with 49 CFR 24.204. KYTC is hereby requesting authorization to advertise this project for bids and to proceed with bid letting even though the necessary right of way will not be fully acquired, and/or some occupants will not be relocated, and/or the just compensation will not be paid or deposited with the court for some parcels until after bid letting. KYTC will fully meet all the requirements outlined in 23 CFR 635.309(c)(3) and 49 CFR 24.102(j) and will expedite completion of all acquisitions, relocations, and full payments after bid letting and prior to AWARD of the construction contract or force account construction.							
Total Number of Parcels on Project		1	EXCEPTION (S) Parcel #		ANTICIPATED DATE OF POSSESSION WITH EXPLANATION		
Number of Parcels That Have Been Acquired							
Signed Deed		1					
Condemnation							
Signed ROE							
<b>Notes/ Comments (Use Additional Sheet if necessary)</b>							
LPA RW Project Manager				Right of Way Supervisor			
Printed Name				Printed Name		Tom Boykin	
Signature				Signature			
Date				Date		4/3/2019	
Right of Way Director				FHWA			
Printed Name		Digitally signed by DM Loy Date: 2019.04.03 14:29:50 -04'00'		Printed Name			
Signature				Signature			
Date				Date			



## UTILITIES AND RAIL CERTIFICATION NOTE

**Bullitt County**  
**FD04 015 94728 01C**  
**Repair Slide on KY 44 0.052 Mile East of Central Blvd**  
**ITEM NUMBER: 5-0900.OTH**

### PROJECT NOTES ON UTILITIES

Please Note: The information presented in this Utility Note is informational in nature and the information contained herein is not guaranteed.

The contractor will be responsible for contacting all utility facility owners on the subject project to coordinate his activities. The contractor will coordinate his activities to minimize and, where possible, avoid conflicts with utility facilities. Due to the nature of the work proposed, it is unlikely to conflict with the existing utilities beyond minor facility adjustments. Where conflicts with utility facilities are unavoidable, the contractor will coordinate any necessary relocation work with the facility owner and Resident Engineer. The Kentucky Transportation Cabinet maintains the right to remove or alter portions of this contract if a utility conflict occurs. The utility facilities as noted in the previous section(s) have been determined using data garnered by varied means and with varying degrees of accuracy: from the facility owners, a result of S.U.E., field inspections, and/or reviews of record drawings. The facilities defined may not be inclusive of all utilities in the project scope and are not Level A quality, unless specified as such. It is the contractor's responsibility to verify all utilities and their respective locations before excavating.

The contractor shall make every effort to protect underground facilities from damage as prescribed in the Underground Facility Damage Protection Act of 1994, Kentucky Revised Statute KRS 367.4901 to 367.4917. It is the contractor's responsibility to determine and take steps necessary to be in compliance with federal and state damage prevention directives. The contractor is instructed to contact KY 811 for the location of existing underground utilities. Contact shall be made a minimum of two (2) and no more than ten (10) business days prior to excavation. The contractor shall submit Excavation Locate Requests to the Kentucky Contact Center (KY 811) via web ticket entry. The submission of this request does not relieve the contractor from the responsibility of contacting non-member facility owners, whom are to be contacted through their individual Protection Notification Center. It may be necessary for the contractor to contact the County Court Clerk to determine what utility companies have facilities in the area. Non-compliance with these directives can result in the enforcement of penalties.

## UTILITIES AND RAIL CERTIFICATION NOTE

**Bullitt County**  
**FD04 015 94728 01C**  
**Repair Slide on KY 44 0.052 Mile East of Central Blvd**  
**ITEM NUMBER: 5-0900.OTH**

**NOTE: DO NOT DISTURB THE FOLLOWING FACILITIES LOCATED WITHIN THE PROJECT DISTURB LIMITS**

**Mt. Washington Sewer & Water Commission – Sewer** has facilities that require relocation. Please see the notes below pertaining to their relocations.

**Louisville Gas and Electric Company - Natural Gas** has an existing 8” high pressure gas main that runs the length of the project. See the bullets below regarding construction around this gas main. **These facilities are not to be disturbed and will remain in place.**

- The high pressure gas main in this area is a critical feed to the natural gas distribution systems in Bullitt and Nelson Counties. The utmost care is to be taken to protect and prevent damage to the gas main and its coating. This gas main cannot be repaired if damaged.
- The contractor shall contact LG&E two (2) weeks prior to construction to discuss the schedule for pipe excavation and install around the active gas main. The contractor and LG&E representative shall discuss plans for safety, staging, and construction before project begins. A list of all equipment, including manufacturer and model, with a gross weight greater than 10,000 lbs. shall be submitted to LG&E two (2) weeks prior to construction. LG&E shall review the stresses imposed on the pipe by the equipment crossing. LG&E reserves the right to restrict equipment crossings to prevent damage to underground facilities.
- An LG&E representative shall be on site during work around the existing utility. No work shall be performed within 5 ft. in all directions of the gas main without an LG&E representative on site. As directed by LG&E, manufactured sand shall be used around the existing gas main with a minimum thickness of 6” in all directions. Low strength diggable flowable fill may then be used for maintenance, accessibility, and protection. All other sections of pipe will be backfilled according to KYTC standard drawings. This additional effort will be incidental to drainage pipe installation.
- The LG&E representative reserves the right to halt work at any time to prevent unsafe working conditions and protect company facilities.
- All personnel working around LG&E’s gas main must be confirmed by the onsite LG&E representative daily to have been instructed of the extreme hazards associated with working near the exposed gas main.

**\*The Contractor is fully responsible for protection of all utilities listed above\***

## UTILITIES AND RAIL CERTIFICATION NOTE

<p style="text-align: center;"><b>Bullitt County</b> <b>FD04 015 94728 01C</b> <b>Repair Slide on KY 44 0.052 Mile East of Central Blvd</b> <b>ITEM NUMBER: 5-0900.OTH</b></p>
--

**THE FOLLOWING FACILITY OWNERS ARE RELOCATING/ADJUSTING THEIR FACILITIES WITHIN THE PROJECT LIMITS AND WILL BE COMPLETE PRIOR TO CONSTRUCTION**

Not Applicable

**THE FOLLOWING FACILITY OWNERS HAVE FACILITIES TO BE RELOCATED/ADJUSTED BY THE OWNER OR THEIR SUBCONTRACTOR AND IS TO BE COORDINATED WITH THE ROAD CONTRACT**

Not Applicable

**THE FOLLOWING FACILITY OWNERS HAVE FACILITIES TO BE RELOCATED/ADJUSTED BY THE ROAD CONTRACTOR AS INCLUDED IN THIS CONTRACT**

Mt. Washington Sewer & Water Commission – has an existing 10” PVC force main which is located south of, and parallel to, KY 44 for the entire length of the project and is to be relocated by the roadway contractor. See U00100.PL for a detailed layout of the proposed force main.

**RAIL COMPANIES HAVE FACILITIES IN CONJUNCTION WITH THIS PROJECT AS NOTED**

No Rail Involvement     Rail Involved     Rail Adjacent

## UTILITIES AND RAIL CERTIFICATION NOTE

**Bullitt County**  
**FD04 015 94728 01C**  
**Repair Slide on KY 44 0.052 Mile East of Central Blvd**  
**ITEM NUMBER: 5-0900.OTH**

### Utility Owners and Contact Persons Bullitt County, KY

---

- |  |   |  |  |   |   |   |
|--|---|--|--|---|---|---|
| <b>1.</b> LG&E KU (Electric)<br>820 West Broadway<br>Louisville, KY 40202<br>LG&E Emergency Number (502) 589-1444<br>LG&E and KU Emergency Number 1-800-331-7370 | <b>2.</b> LG&E (Gas)<br>820 West Broadway<br>Louisville, KY 40202<br>Gas Emergency Number (502) 589-5511<br>LG&E and KU Emergency Number 1-800-331-7370 | <b>3.</b> Louisville Water Company<br>550 South Third Street<br>Louisville, KY 40202 | <b>4.</b> Windstream Kentucky, Inc.<br>229 Lees Valley Road<br>Shepherdsville, KY 40165<br><a href="mailto:Rondale.langley@Windstream.com">Rondale.langley@Windstream.com</a><br>502-957-7127<br><b>OR</b><br>111 S. Main St.<br>Elizabethtown, KY 42071 | <b>5.</b> Salt River Rural Electric Coop. Corp.<br>111 W. Brashear Ave.<br>Bardstown, KY 40004<br>Telephone in Bullitt County | <b>6.</b> East Kentucky Power Coop<br>4775 Lexington Road | <p>Caroline Justice<br/>work: (502) 627-3708<br/><a href="mailto:caroline.justice@LGE-KU.com">caroline.justice@LGE-KU.com</a></p> <p>Caroline Justice<br/>work: (502) 627-3708<br/><a href="mailto:caroline.justice@LGE-KU.com">caroline.justice@LGE-KU.com</a></p> <p>Daniel Tegene, PE<br/>(502) 569-3649<br/><a href="mailto:DTegene@LWCKy.com">DTegene@LWCKy.com</a></p> <p>Rondale Langley<br/>(270) 765-1817</p> <p>Barry Roberts<br/>(270) 723-7358<br/><a href="mailto:Barry.Roberts@Windstream.com">Barry.Roberts@Windstream.com</a></p> <p>Daniel Carrico<br/><a href="mailto:Dcarrico@SRElectric.com">Dcarrico@SRElectric.com</a><br/>(502) 350-1606</p> <p>Garry Harvey<br/>(859)745-9601</p> |
|--|---|--|--|---|---|---|

## UTILITIES AND RAIL CERTIFICATION NOTE

**Bullitt County**  
**FD04 015 94728 01C**  
**Repair Slide on KY 44 0.052 Mile East of Central Blvd**  
**ITEM NUMBER: 5-0900.OTH**

- |   |    |  |
|---|----|--|
| Winchester, KY 40391  | Or | <a href="mailto:Garry.Harvey@EKPC.coop">Garry.Harvey@EKPC.coop</a><br>Barry Warner<br><a href="mailto:Barry.Warner@EKPC.coop">Barry.Warner@EKPC.coop</a><br>(859) 745-9304   |
| <b>7.</b> City of Shepherdsville Sewer<br>634 Conestoga Parkway<br>P O Box 400<br>Shepherdsville, KY 40165    |    | Engineer: Arthur Jones<br>ph: (502) 492-7404<br><a href="mailto:ajones@shepcity.com">ajones@shepcity.com</a><br>fax: (502) 543-2923 (City Shep)<br>ph: (502) 955-7803 (City Shep)<br>Scott Flemming<br>Cell: (502) 664-6254<br><a href="mailto:sfleming@shepcity.com">sfleming@shepcity.com</a>  |
| <b>8.</b> Charter Communications<br>10168 Linn Station Road<br>Suite 120<br>Louisville, KY 40223              |    | Deno Barbour<br>(502) 664-7395 – Cell<br>(502) 357-4376 – Office<br><a href="mailto:Dwight.Barbour@charter.com">Dwight.Barbour@charter.com</a><br>Kevin Mercer<br>(502) 817-5055 – Cell<br>(502) 357-4724 - Office<br><a href="mailto:kevin.mercer@charter.com">kevin.mercer@charter.com</a><br>Richard Bast<br>(502) 817-0734 – Cell<br>(502) 357-4118 - Office<br><a href="mailto:richard.bast@charter.com">richard.bast@charter.com</a> |
| <b>9.</b> Lebanon Junction Water Works<br>City Hall - Main Street<br>P O Box 69<br>Lebanon Junction, KY 40150 |    | Charles Sullivan<br>Cell (502) 817-0352<br><a href="mailto:LJWW16@yahoo.com">LJWW16@yahoo.com</a><br>City Hall 502-833-4311  |
| <b>10.</b> Mt. Washington Sewer & Water Commission<br>311 Snapp Street<br>Mt. Washington, KY 40047            |    | Elizabeth Hall, City Administrator<br><a href="mailto:DHall@mtwky.org">DHall@mtwky.org</a><br>Derrick Engineering – Consultant   |

## UTILITIES AND RAIL CERTIFICATION NOTE

**Bullitt County**  
**FD04 015 94728 01C**  
**Repair Slide on KY 44 0.052 Mile East of Central Blvd**  
**ITEM NUMBER: 5-0900.OTH**

(502) 538-4216 or 538-4781 or 955-6784

[derrickinc@bellsouth.net](mailto:derrickinc@bellsouth.net)

Ronnie Fick, Public Works Director

[RFick@mtwKY.org](mailto:RFick@mtwKY.org)

(502)538-3771

**11.** Marathon Pipeline, LLC  
539 South Main Street, Room X-05-018  
Findlay, OH 45840  
OR  
20-C Industrial Drive  
Lexington, OH 44904

Dennis Durnal

Office – (502) 448-8311

Cell – (419) 581-0038

[ddurnal@marathonpetroleum.com](mailto:ddurnal@marathonpetroleum.com)

Greg Newman

[gcnewman@marathonpetroleum.com](mailto:gcnewman@marathonpetroleum.com)

Office - (419) 884-0800x236

Cell – (419) 564-8826

**12.** Mid - Valley Pipeline Company  
4910 Limaburg Road  
Burlington, KY 41005  
FAX (866) 699-1185

Richard (Todd) Calfee

(859) 371-4469x14

Cell: 859-630-8271

[RTCalfee@SunocoLogistics.com](mailto:RTCalfee@SunocoLogistics.com)

**13.** AT&T Legacy  
7555 E. Pleasant Valley Rd. – Suite 140  
Independence, OH 44131

Mike Diederich

[MD4145@att.com](mailto:MD4145@att.com)

Phone - (216) 750-0135

Cell - (216) 212-8556

Don Garr

[DRGarr@Hughes.net](mailto:DRGarr@Hughes.net)

Cell - (502) 741-8374

**14.** City of Taylorsville Sewer & Water  
70 Taylorsville Rd., P O Box 279  
Taylorsville, KY 40071  
Consultant: Kevin Sisler  
220 Reynolds Rd  
Lexington, KY 40517

Harold Compton

[HCompton@TaylorsvilleWater.org](mailto:HCompton@TaylorsvilleWater.org)

(502) 477-3235

[Kevin.@SislerMaggard.com](mailto:Kevin.@SislerMaggard.com)

(859) 271-2978 (859) 509-3799

Steve Biven-City Clerk

[SBiven@taylorsvillewater.org](mailto:SBiven@taylorsvillewater.org)

(502) 477-3235 ext. 106

Scott Roche

[sr8832@att.com](mailto:sr8832@att.com)

Office - (502) 348-4528

Cell – (502) 827-4703

**15.** AT&T KY  
1340 E. John Rowan Blvd  
Bardstown, KY 40004

## UTILITIES AND RAIL CERTIFICATION NOTE

**Bullitt County**  
**FD04 015 94728 01C**  
**Repair Slide on KY 44 0.052 Mile East of Central Blvd**  
**ITEM NUMBER: 5-0900.OTH**

- |  |   |
|--|---|
| <p><b>16.</b> Bullitt County Schools<br/>1040 Highway 44 East<br/>Shepherdsville, KY 40165<br/>(also managed by LG Fiber)<br/>LG Fiber<br/>P. O. Box 1702<br/>Mt. Vernon, KY 40456</p> | <p>Jim Jackson<br/><a href="mailto:Jim.Jackson@Bullitt.kyschools.us">Jim.Jackson@Bullitt.kyschools.us</a><br/>(502) 869-8040<br/>Larry Gregory<br/><a href="mailto:LGFiber@gmail.com">LGFiber@gmail.com</a><br/>(606)521-2649</p>   |
| <p><b>17.</b> Bullitt Co. Sanitation District<br/>P O Box 818<br/>Hillview, KY 40129</p>   | <p>Jerry Kennedy<br/>Office – (502) 957-6140<br/>Cell - (502) 643-3165<br/><a href="mailto:BullittSanitation@Windstream.net">BullittSanitation@Windstream.net</a></p>   |
| <p><b>18.</b> Inside Connect Cable LLC<br/>4890 Knobb Creek Road<br/>Brooks, KY 40109</p>  | <p>TJ Scott<br/><a href="mailto:tscott@insideconnect.net">tscott@insideconnect.net</a><br/>Tony Manley<br/><a href="mailto:Tony@InsideConnect.net">Tony@InsideConnect.net</a><br/>or <a href="mailto:Tony@ICcable.com">Tony@ICcable.com</a><br/>Office: (502)955-4882<br/>Cell: (502)593-5357</p> |
| <p><b>19.</b> Pioneer Village Sewer Plant<br/>4846 Brownsboro Center Arcade<br/>Louisville, KY 40242<br/>502-895-4273</p>  | <p>Joe Sanders<br/>(502) 609-2114 - cell<br/>NO EMAIL<br/>Owner: Jim Walser</p>   |
| <p><b>20.</b> Kentucky Data Link (KDL now Windstream)<br/>111 S. Main St.<br/>Elizabethtown, KY 42071</p>  | <p>James Galvin<br/>Office: 270-765-1818<br/>Mobile: 270-748-9249<br/><a href="mailto:James.Galvin@windstream.com">James.Galvin@windstream.com</a><br/>Mark Ware<br/><a href="mailto:Mark.Ware@windstream.com">Mark.Ware@windstream.com</a></p>   |
| <p><b>21.</b> Verizon Business (MCI)<br/>400 International Parkway<br/>Richardson, TX 75081</p>  | <p>Dean Boyers (Investigations Dept)<br/><a href="mailto:Dean.Boyers@Verizon.com">Dean.Boyers@Verizon.com</a><br/>Office (469) 886-4238</p>   |
| <p><b>22.</b> Nolin Rural Electric Cooperative Corp.</p>   | <p>Donnie Probst</p>  |

## UTILITIES AND RAIL CERTIFICATION NOTE

**Bullitt County**  
**FD04 015 94728 01C**  
**Repair Slide on KY 44 0.052 Mile East of Central Blvd**  
**ITEM NUMBER: 5-0900.OTH**

- 411 Ring Road  
Elizabethtown, KY 42701 (270) 765-6153
- 23.** CenturyLink  
260 Winn Ave  
Winchester, KY 40391  
Jim Trapnell  
[jim.trapnell@centurylink.com](mailto:jim.trapnell@centurylink.com)  
Cell (859) 806-5833
- 24.** CenturyLink  
848 S. 8<sup>th</sup> St.  
Louisville, KY 40203  
Kevin Webster  
[Kevin.Webster@Level3.com](mailto:Kevin.Webster@Level3.com)  
Office (502) 777-8622  
Cell (502) 777-8622  
Fax (502) 561-6950
- CenturyLink  
11857 Commonwealth Drive  
Louisville, KY 40299  
Mark Sewell  
[Mark.Sewell@Level3.com](mailto:Mark.Sewell@Level3.com)  
Office (502) 389-4811  
Cell (502) 295-0939
- 3770 Lucius Rd.  
Columbia, SC 29201  
Russ Wheat, Relocation Project Manager  
[russ.wheat@level3.com](mailto:russ.wheat@level3.com)  
Office (803) 239-1116  
Cell (803) 206-9563
- 25.** Crown Castle Network Operations  
10300 Ormsby Park Place  
Suite 501  
Louisville, KY 40223  
John Demko  
[John.Demko@CrownCastle.com](mailto:John.Demko@CrownCastle.com)  
(724) 416-9188  
Chris Gladstone  
[Chris.Gladstone@CrownCastle.com](mailto:Chris.Gladstone@CrownCastle.com)  
(502) 689-2162
- 26.** MCI/Verizon(Owns WUTEL)  
MCI/Verizon  
730 West Henry Street  
Indianapolis, IN 46225  
David Dickerson  
[david.b.dickerson@xo.com](mailto:david.b.dickerson@xo.com)  
Office: (615) 777-7855  
Cell: (615) 507-5287
- Dave Wiley (Field)



## UTILITIES AND RAIL CERTIFICATION NOTE

**Bullitt County**  
**FD04 015 94728 01C**  
**Repair Slide on KY 44 0.052 Mile East of Central Blvd**  
**ITEM NUMBER: 5-0900.OTH**

**27.** Kentucky Wired  
209 St. Clair Street, 4<sup>th</sup> Floor  
Frankfort, KY 40601

(502) 439-8783  
[dave.wiley@verizon.com](mailto:dave.wiley@verizon.com)

Mike Hayden, Chief Operating Officer  
Office 502-782-2535  
[Mike.Hayden@ky.gov](mailto:Mike.Hayden@ky.gov)  
Harold Waters, Lead  
Engineering Specialist, Black&Veatch  
Office (913) 458-1584  
Cell (502) 612-8495  
[watershw@bv.com](mailto:watershw@bv.com)

# **GENERAL UTILITY NOTES AND INSTRUCTIONS APPLICABLE TO ALL UTILITY WORK MADE A PART OF THE ROAD CONSTRUCTION CONTRACT**

The contractor should be aware the following utility notes and KYTC Utility Bid Item Descriptions shall supersede, replace and take precedence over any and all conflicting information that may be contained in utility owner supplied specifications contained in the contract, on plans supplied by the utility owner, or any utility owner specifications or information externally referenced in this contract.

Where information may have been omitted from these notes, bid item descriptions, utility owner supplied specifications or plans; the KYTC Standard Specifications for Road and Bridge Construction shall be referenced.

## **PROTECTION OF EXISTING UTILITIES**

The existing utilities shown on the plans are shown as best known at the time the plans were developed and are to be used as a guide only by the Contractor. The Contractor shall use all means at his disposal to accurately locate all existing utilities, whether shown on the plans or not, prior to excavation. The contractor shall protect these utilities during construction. Any damage to existing utilities during construction that are shown or not shown on the plans shall be repaired at the Contractor's expense.

## **PREQUALIFIED UTILITY CONTRACTORS**

Some utility owners may require contractors that perform relocation work on their respective facilities as a part of the road contract be prequalified or preapproved by the utility owner. Those utility owners with a prequalification or preapproval requirement are as follows:

***No contractors are required to be prequalified or preapproved by the utility owner(s) to perform utility relocation work under this contract.***

The bidding contractor needs to review the above list and choose from the list of approved subcontractors at the end of these general notes as identified above before bidding. When the list of approved subcontractors is provided, only subcontractors shown on the following list(s) will be allowed to work on that utility as a part of this contract.

When the list of approved subcontractors for the utility work is not provided in these general notes, the utility work can be completed by the prime contractor. If the prime contractor chooses to subcontract the work, the subcontractor shall be prequalified with the KYTC Division of Construction Procurement in the

work type of “Utilities” (I33). Those who would like to become prequalified may contact the Division of Construction Procurement at (502) 564-3500. Please note: it could take up to 30 calendar days for prequalification to be approved. The prequalification does not have to be approved prior to the bid, but must be approved before the subcontract will be approved by KYTC and the work can be performed.

#### CONTRACT ADMINISTRATION RELATIVE TO UTILITY WORK

All utility work is being performed as a part of a contract administered by KYTC; there is not a direct contract between the utility contractor and utility owner. The KYTC Section Engineer is ultimately responsible for the administration of the road contract and any utility work included in the contract.

#### SUBMITTALS AND CORRESPONDENCE

All submittals and correspondence of any kind relative to utility work included in the road contract shall be directed to the KYTC Section Engineer, a copy of which may also be supplied to the utility owner by the contractor to expedite handling of items like material approvals and shop drawings. All approvals and correspondence generated by the utility owner shall be directed to the KYTC Section Engineer. The KYTC Section Engineer will relay any approvals or correspondence to the utility contractor as appropriate. At no time shall any direct communication between the utility owner and utility contractor without the communication flowing through the KYTC Section Engineer be considered official and binding under the contract.

#### ENGINEER

Where the word “Engineer” appears in any utility owner specifications included in this proposal, utility owner specifications included as a part of this contract by reference or on the utility relocation plans, it shall be understood the “Engineer” is the Kentucky Transportation Cabinet (KYTC) Section Engineer or designated representative and the utility owner engineer or designated representative jointly. Both engineers must mutually agree upon all decisions made with regard to the utility construction. The Transportation Cabinet, Section Engineer shall make all final decisions in all disputes.

### INSPECTOR OR RESIDENT PROJECT REPRESENTATIVE

Where the word “Inspector” or “Resident Project Representative” appears in the utility specifications included in this proposal, utility owner specifications included as a part of this contract by reference or on the utility relocation plans, it shall be understood the “Inspector” or “Resident Project Representative” is the utility owner inspector and KYTC inspector jointly. The Transportation Cabinet, Section Engineer shall make all final decisions in all disputes.

### NOTICE TO UTILITY OWNERS OF THE START OF WORK

One month before construction is to start on a utility, the utility contractor shall make notice to the KYTC Section Engineer and the utility owner of when work on a utility is anticipated to start. The utility contractor shall again make confirmation notice to the KYTC Section Engineer and the utility owner one week before utility work is to actually start.

### UTILITY SHUTDOWNS

The Contractor shall not shut down any active and in-service mains, utility lines or services for any reason unless specifically given permission to do so by the utility owner. The opening and closing of valves and operating of other active utility facilities for main, utility line or utility service shut downs are to be performed by the utility owner unless specific permission is given to the contractor by the owner to make shutdowns . If and when the utility owner gives the contractor permission to shutdown mains, utility lines or utility services, the contractor shall do so following the rules, procedures and regulations of the utility owner. Any permission given by the utility owner to the contractor to shutdown active and in-service mains, utility lines or services shall be communicated to the KYTC Section Engineer by the utility owner that such permission has been given.

Notice to customers of utility shut downs is sometimes required to be performed by the utility contractor. The contractor may be required; but, is not limited to, making notice to utility customers in a certain minimum amount of time in advance of the shut down and by whatever means of communication specified by the utility owner. The means of communication to the customer may be; but is not limited to, a door hanger, notice by newspaper ad, telephone contact, or any combination of communication methods deemed necessary, customary and appropriate by the utility owner. The contractor should refer to the utility owner specifications for requirements on customer notice.

Any procedure the utility owner may require the contractor to perform by specification or plan note and any expense the contractor may incur to comply with the utility owner’s shut down procedure and notice to customers shall be considered an incidental expense to the utility construction.

CUSTOMER SERVICE AND LATERAL ABANDONMENTS When temporary or permanent abandonment of customer water, gas, or sewer services or laterals are necessary during relocation of utilities included in the contract, the utility contractor shall perform these abandonments as part of the contract as incidental work. No separate payment will be made for service line and lateral abandonments. The contractor shall provide all labor, equipment and materials to accomplish the temporary or permanent abandonment in accordance with the plans, specifications and/or as directed by the engineer. Abandonment may include, but is not limited to, digging down on a water or gas main at the tap to turn off the tap valve

or corporation stop and/or capping or plugging the tap, digging down on a sewer tap at the main and plugging or capping the tap, digging down on a service line or lateral at a location shown on the plans or agreeable to the engineer and capping or plugging, or performing any other work necessary to abandon the service or lateral to satisfactorily accomplish the final utility relocation.

### STATIONS AND DISTANCES

All stations and distances, when indicated for utility placement in utility relocation plans or specifications, are approximate; therefore, some minor adjustment may have to be made during construction to fit actual field conditions. Any changes in excess of 6 inches of plan location shall be reviewed and approved jointly by the KYTC Section Engineer or designated representative and utility owner engineer or designated representative. Changes in location without prior approval shall be remedied by the contractor at his own expense if the unauthorized change creates an unacceptable conflict or condition.

### RESTORATION

Temporary and permanent restoration of paved or stone areas due to utility construction shall be considered incidental to the utility work. No separate payment will be made for this work. Temporary restoration shall be as directed by the KYTC Section Engineer. Permanent restoration shall be "in-kind" as existing.

Restoration of seed and sod areas will be measured and paid under the appropriate seeding and sodding bid items established in the contract for roadway work.

---

BELOW ARE NOTES FOR WHEN "INST" ITEMS ARE IN THE CONTRACT MEANING THE UTILITY COMPANY IS PROVIDING CERTAIN MATERIALS FOR UTILITY RELOCATION

### MATERIAL

Contrary to Utility Bid Item Descriptions, those bid items that have the text "**Inst**" at the end of the bid item will have the major components of the bid item provided by the utility owner. No direct payment will be made for the major material component(s) supplied by the utility company. All remaining materials required to construct the bid item as detailed in utility bid item descriptions, in utility specifications and utility plans that are made a part of this contract will be supplied by the contractor. The contractor's bid price should reflect the difference in cost due to the provided materials.

The following utility owners have elected to provide the following materials for work under this contract:

***No materials are being supplied by the utility owner(s). All materials are to be supplied by the contractor per bid item descriptions, utility specifications and utility plans.***

### SECURITY OF SUPPLIED MATERIALS

If any utility materials are to be supplied by the utility owner, it will be the responsibility of the utility contractor to secure all utility owner supplied materials after delivery to the project site. The utility

contractor shall coordinate directly with the utility owner and their suppliers for delivery and security of the supplied materials. Any materials supplied by the utility owner and delivered to the construction site that are subsequently stolen, damaged or vandalized and deemed unusable shall be replaced with like materials at the contractor's expense.

# Standard Sanitary Sewer Bid Item Descriptions

**S BYPASS PUMPING** This item shall include all labor, equipment, and materials needed to complete a bypass pumping and/or hauling operation for diversion of sewage during sanitary sewer construction. Examples of such operations when bypass pumping and/or hauling may be necessary is during force main tie-ins, manhole invert reconstruction, insertion of new manholes into existing mains, or other similar construction. There may be more than one bypass pumping/hauling operation on a project. This item shall be paid for each separate bypass pumping/hauling operation occurrence as called out on the plans or directed by the engineer and actually performed. There will be no separate bid items defined for length, duration, or volume of sewage pumped or hauled in each occurrence. If a bypass pumping/hauling operation is called out on the plans; but, conditions are such that the bypass pumping/hauling operation is not needed or utilized, no payment will be made under this item. The contractor shall draw his own conclusions as to what labor, equipment, and materials may be needed for each bypass pumping/hauling occurrence. The contractor should be prepared to handle the maximum volume of the sewer being bypassed, even during a storm event. This item shall not be paid separately, but shall be considered incidental, when bypass pumping and/or hauling is needed during cast-in-place-pipe (CIPP) and/or point repair operations. Please refer to the Utility Company's Specifications. If the Company does not have specifications, KYTC's Specifications shall be referenced. This item shall be paid EACH (EA).

**S CIPP LATERAL SERVICE INVESTIGATION** This item shall include all equipment, materials, labor and incidentals necessary to enter the sewer in compliance with all safety/confined space requirements and perform the identification, assessment and pre-measurement of all existing and abandoned laterals for the placement of Cured-In-Place-Pipe lining. This item shall be in payment for all lateral service investigation for all sewer segments to be lined as a part of this contract. This bid item shall include bypass pumping when required. Please refer to the Utility Company's Specifications. If the Company does not have specifications, KYTC's Specifications shall be referenced. Payment for this item shall be LUMP SUM (LS).

**S CIPP LATERAL REINSTATEMENT** This item is to pay for installing a Cured-In-Place-Pipe liner in service laterals and service/mainline connections to stabilize structural defects and construction inadequacies. This bid item shall include all labor, equipment, materials and incidentals necessary to perform the service lateral reinstatement in accordance with the plans and specifications. Work under this item shall include bypass pumping, sewer flow control, pre-installation cleaning, sealing connections to existing sewer main, pre- and post- construction CCTV inspection and final testing of the CIPP system. This item shall also include the "top hat" required by the specifications. All CIPP lateral reinstatements shall be paid under this item regardless of the size or length of reinstatement. No separate bid items of varying sizes or length of CIPP lateral reinstatement will be provided in the contract. Please refer to the Utility Company's Specifications. If the Company does not have specifications, KYTC's Specifications shall be referenced. Payment for this item shall be EACH (EA) for each CIPP lateral reinstatement complete and ready for use.

**S CIPP LINER** This bid Item is to pay for rehabilitation of existing sanitary sewers using the Cured-In-Place-Pipe method. This bid item description applies to all CIPP sizes included in the contract.

All CIPP Liner items of all varying sizes shall include all labor, materials, customer notification, testing, necessary permits, ingress and egress procedures, bypass pumping, pre-construction video, sediment and root removal, dewatering, traffic control, erosion and sediment control, excavation pits, removal and replacement of manhole frames and covers as necessary to facilitate the lining work, sealing at manholes and service connections, clearing and grubbing, pipeline cleaning, re-cleaning and video inspection as many times as necessary, debris collection and disposal, root removal, pre- and post-construction video inspection, all digital inspection footage, final report preparation and approval, the cost of potable water from the Owner, required compliance tests, site restoration, site cleanup, sealing of liner at manholes, acceptance testing and all other rehabilitation work and incidentals not included under other pay items necessary to complete the rehabilitation per the plans and specifications. There will be no separate payment for acceptance testing of the lined pipe; but shall be considered incidental to this item. Pay under this item shall be by each size bid in the contract. Pay measurement shall be from center of manhole to center of manhole. Please refer to the Utility Company's Specifications. If the Company does not have specifications, KYTC's Specifications shall be referenced. This item shall be paid LINEAR FEET (LF).

**S CIPP PROTRUDING LATERAL REMOVAL** This item includes all equipment, materials, labor and incidentals necessary to enter the sewer in compliance with all safety/confined space requirements, remove a sufficient amount of the protruding tap to insure a proper and safe Cured-In-Place-Pipe lining insertion and perform pre-installation CCTV. This bid item shall include bypass pumping when required. Please refer to the Utility Company's Specifications. If the Company does not have specifications, KYTC's Specifications shall be referenced. Payment for this item shall be EACH (EA) for each protruding lateral removed.

**S CONCRETE PIPE ANCHOR** This item shall be constructed on the sewer pipe at the locations shown on the plans in accordance with sanitary sewer specifications and standard drawings. Payment for concrete anchors will be made at the contract unit price each in place complete and ready for use. Each concrete anchor of sewer pipe or force main shall be paid under one bid item per contract regardless of the sizes of carrier pipe being anchored in the contract. No separate bid items will be established for size variations. Please refer to the Utility Company's Specifications. If the Company does not have specifications, KYTC's Specifications shall be referenced. This item shall be paid EACH (EA) when complete.

**S DIRECTIONAL BORE** Payment under this item is made whenever the plans or specifications specifically show directional boring is to be utilized in order to minimize the impact of open cut for the installation of force main or gravity sewer under streets, creeks, and etc. Payment under this item shall include the specified bore pipe, labor, and equipment. No separate payment shall be made for bore pipe installed in the bore whether used as a carrier pipe or an encasement of a separate carrier pipe. This item shall also include pipe anchors at each end of the bore when specified to prevent the creep or contraction of the bore pipe. Carrier pipe installed within a bore pipe shall be paid separately under pipe items. Payment under this item shall not be size specific and no separate bid items will be established for size variations. The bore pipe sizes to be included under this item shall be as shown on the plans and/or in the specifications. Any and all directional bores in each contract shall be paid under one directional bore bid item included in the contract regardless of size. Please refer to the Utility Company's Specifications. If the Company does not have specifications, KYTC's Specifications shall be referenced. This item shall be paid LINEAR FEET (LF).

**S ENCASEMENT CONCRETE** Includes all labor, equipment, excavation, concrete, reinforcing



steel, backfill, restoration, and etc., to construct the concrete encasement of the sewer or force main as shown on the plans, and in accordance with the specifications and standard drawings. Payment under this item shall be in addition to the carrier pipe as paid under separate bid items. Carrier pipe is not included in this bid item. Any and all concrete encasement shall be paid under one bid item included in the contract regardless of the size of the carrier pipe or the volume of concrete or steel reinforcement as specified in the plans and specifications. No separate bid items will be established for size variations. Measurement of pay quantity shall be from end of concrete to end of concrete. Please refer to the Utility Company's Specifications. If the Company does not have specifications, KYTC's Specifications shall be referenced. This item shall be paid LINEAR FEET (LF) when complete.

**S ENCASEMENT STEEL BORED** This item shall include the steel encasement pipe size as specified on the plans and in the specifications, casing spacers, end seals, labor, and equipment to bore and install the encasement in accordance with the plans and specifications, complete and ready for use. The size shall be the measured internal diameter of the encasement pipe. The sizes of encasement to be paid under the size ranges specified in the bid items shall be as follows:

- Range 1 = All encasement sizes greater than 2 inches to and including 6 inches
- Range 2 = All encasement sizes greater than 6 inches to and including 10 inches
- Range 3 = All encasement sizes greater than 10 inches to and including 14 inches
- Range 4 = All encasement sizes greater than 14 inches to and including 18 inches
- Range 5 = All encasement sizes greater than 18 inches to and including 24 inches
- Range 6 = All encasement sizes greater than 24 inches

*(Encasement sizes of 2 inches internal diameter or less shall not be paid separately; but, shall be considered incidental to the carrier pipe.)* Payment under this bid item shall not include the carrier pipe. Carrier pipe shall be paid under a separate bid item. Please refer to the Utility Company's Specifications. If the Company does not have specifications, KYTC's Specifications shall be referenced. This item shall be paid LINEAR FEET (LF).

**S ENCASEMENT STEEL OPEN CUT** This item shall include the steel encasement pipe size as specified on the plans and in the specifications, casing spacers, end seals, labor, and equipment to open cut install the encasement in accordance with the plans and specifications, complete and ready for use. The size shall be the measured internal diameter of the encasement pipe. The size encasement to be paid under the size ranges specified in the bid items shall be as follows:

- Range 1 = All encasement sizes greater than 2 inches to and including 6 inches
- Range 2 = All encasement sizes greater than 6 inches to and including 10 inches
- Range 3 = All encasement sizes greater than 10 inches to and including 14 inches
- Range 4 = All encasement sizes greater than 14 inches to and including 18 inches
- Range 5 = All encasement sizes greater than 18 inches to and including 24 inches
- Range 6 = All encasement sizes greater than 24 inches

*(Encasement sizes of 2 inches internal diameter or less shall not be paid separately; but, shall be considered incidental to the carrier pipe.)* Payment under this bid item shall not include the carrier pipe. Carrier pipe shall be paid under a separate bid item. Please refer to the Utility Company's Specifications. If the Company does not have specifications, KYTC's Specifications shall be referenced. This item shall be paid LINEAR FEET (LF).

**S FORCE MAIN** This description shall apply to all PVC and ductile iron and polyethylene/plastic pipe bid items of every size and type, except those bid items defined as “Special”. This item includes the pipe specified by the plans and specifications, all fittings (including, but not limited to, bends, tees, reducers, plugs, and caps), tracing wire with test boxes (if required by specification), polyethylene wrap (when specified), labor, equipment, excavation, bedding, restoration, testing, backfill, and etc., required to install the specified new pipe and new fittings at the locations shown on the plans, or as directed, in accordance with the specifications and standard drawings complete and ready for use. No additional payment will be made for rock excavation. This bid item includes material and placement of flowable fill under existing and proposed pavement, and wherever else specified on the plans or in the specifications. This item shall also include pipe anchors on polyethylene pipe runs as shown on the plans or required by the specifications to prevent the creep or contraction of the pipe. Measurement of quantities under this item shall be through fittings, encasements, and directional bores (only when a separate carrier pipe is specified within the directional bore pipe). No separate payment will be made under pipe items when the directional bore pipe is the carrier pipe. Measurements shall be further defined to be to the center of tie-in where new pipe contacts existing pipe at the center of connecting fittings, to the outside face of vault or structure walls, or to the point of main termination at dead ends. Please refer to the Utility Company’s Specifications. If the Company does not have specifications, KYTC’s Specifications shall be referenced. This item shall be paid LINEAR FEET (LF).

**S FORCE MAIN AIR RLS/VAC VLV** This bid item description shall apply to all force main air release/vacuum valve installations of every size except those defined as “Special”. This item shall include the air release/vacuum valve, main to valve connecting line or piping, manhole/vault/structure, access casting or doors, tapping the main, labor, equipment, excavation, proper backfill and restoration required to install the air release/vacuum valve at the location shown on the plans or as directed in accordance with the specifications and standard drawings complete and ready for use. All air release/vacuum valves on a project shall be paid under one bid item regardless of size. No separate pay items will be established for size variations. Only in the case of the uniqueness of a particular air release/vacuum valve would a separate bid item be established. Please refer to the Utility Company’s Specifications. If the Company does not have specifications, KYTC’s Specifications shall be referenced. This item shall be paid EACH (EA) when complete.

**S FORCE MAIN DIRECTIONAL BORE** Payment under this item is made whenever the plans or specifications specifically show directional boring is to be utilized in order to minimize the impact of open cut for the installation of sewer or force main under streets, buildings, creeks, and etc. Payment under this item shall include the specified bore pipe, labor, and equipment. No separate payment shall be made for bore pipe installed in the bore whether used as a carrier pipe or an encasement of a separate carrier pipe. This item shall also include pipe anchors at each end of the bore when specified to prevent the creep or contraction of the bore pipe. Carrier pipe installed within a bore pipe shall be paid separately under pipe items. Payment under this item shall not be size specific and no separate bid items will be established for size variations. The bore pipe sizes to be included under this item shall be as shown on the plans and/or in the specifications. Any and all directional bores in each contract shall be paid under one directional bore bid item included in the contract regardless of size. Please refer to the Utility Company’s Specifications. If the Company does not have specifications, KYTC’s Specifications shall be referenced. This item shall be paid LINEAR FEET (LF).

**S FORCE MAIN POINT RELOCATE** This item is intended for payment for horizontal and/or vertical relocation of a short length of an existing main at the locations shown on the plans. This bid item is to be used to relocate an existing force main at point locations such as to clear a conflict at a

proposed drainage structure, pipe or any other similar short relocation situation, and where the existing pipe material is to be reused. The contractor shall provide any additional pipe or fitting material needed to complete the work as shown on the plans and specifications. The materials provided shall be of the same type and specification as those that exist. Substitution of alternative materials shall be approved by the engineer in advance on a case by case basis. New polyethylene wrap is to be provided (if wrap exists or is specified in the specifications to be used). If it is necessary that the pipe be disassembled for relay, payment under this item shall also include replacement of joint gaskets as needed. Bedding and backfill shall be provided and performed the same as with any other pipe installation as detailed in the plans and specifications. Payment under this item shall be for each location requiring an existing main to be relocated horizontally or vertically regardless of pipe size or relocation length. No separate pay items will be established for pipe size variations or relocation segment length variations. Force Main Relocate shall not be paid on a linear feet basis; but shall be shall be paid EACH (EA) at each location when complete and placed in service. Please refer to the Utility Company's Specifications. If the Company does not have specifications, KYTC's Specifications shall be referenced.

**S FORCE MAIN TAP SLEVE/VALVE RANGE 1 OR 2** This item shall include the specified tapping sleeve, valve, valve box, concrete pad around valve box (when required in specifications or plans), labor, and equipment to install the specified tapping sleeve and valve, complete and ready for use in accordance with the plans and specifications. The size shall be the measured internal diameter of the live pipe to be tapped. The size tapping sleeve and valve to be paid under sizes 1 or 2 shall be as follows:

- Range 1 = All live tapped main sizes up to and including 8 inches
- Range 2 = All live tapped main sizes greater than 8 inches

Please refer to the Utility Company's Specifications. If the Company does not have specifications, KYTC's Specifications shall be referenced. This item shall be paid EACH (EA) when complete.

**S FORCE MAIN TIE-IN** This bid description shall be used for all force main tie-in bid items of every size except those defined as "Special". This item includes all labor, equipment, excavation, fittings, sleeves, reducers, couplings, blocking, anchoring, restoration, testing and backfill required to make the force main tie-in as shown on the plans and in accordance with the specifications complete and ready for use. This bid item shall include purge and sanitary disposal of any sewage from any abandoned segments of force main. Pipe for tie-ins shall be paid under separate bid items. Please refer to the Utility Company's Specifications. If the Company does not have specifications, KYTC's Specifications shall be referenced. This item shall be paid EACH (EA) when complete.

**S FORCE MAIN VALVE** This description shall apply to all force main valves of every size required in the plans and specifications, except those bid items defined as "Special". Payment under this description is to be for gate or butterfly force main valves being installed with new force main. This item includes the valve as specified in the plans and specifications, polyethylene wrap (if required by specification), labor, equipment, excavation, anchoring (if any), valve box and valve stem extensions, backfill, concrete pad around valve box (if required by specification), restoration, testing, and etc., required to install the specified valve at the location shown on the plans in accordance with the specifications and standard drawings complete and ready for use. If required on plans and/or proposed adjoining DIP is restrained, force main valves shall be restrained. Force main valve restraint shall be considered incidental to the force main valve and adjoining pipe. Please refer to the Utility Company's Specifications. If the Company does not have specifications, KYTC's Specifications shall be

referenced. This item shall be paid EACH (EA) when complete.

**S FORCE MAIN VALVE BOX ADJUST** Includes all labor, equipment, valve box and valve stem extensions (if required), excavation, backfill, concrete pad around valve box (when specified in specifications or plans), restoration, and etc., to adjust the top of the force main valve box to finished grade complete and ready for use. Please refer to the Utility Company's Specifications. If the Company does not have specifications, KYTC's Specifications shall be referenced. This item shall be paid EACH (EA) when complete.

**S LATERAL CLEANOUT** This item shall be for payment for installation of a cleanout in a service lateral line. This item shall include furnishing and installation of a tee, vertical pipe of whatever length required, and threaded cap. The cleanout shall extend from the lateral to final grade elevation. The size of the cleanout shall be equivalent to the size of the lateral. The cleanout materials shall meet the same specification as those for the lateral. The cleanout shall be installed at the locations shown on the plans or as directed by the engineer. Only one pay item shall be established for cleanout installation. No separate pay items shall be established for size or height variances. Please refer to the Utility Company's Specifications. If the Company does not have specifications, KYTC's Specifications shall be referenced. This item shall be paid EACH (EA) when complete.

**S LATERAL LOCATE** This bid item is to pay for all labor, equipment, and materials needed in locating an existing sanitary sewer service lateral for tie-in of the lateral to new mainline sewers and/or for the relocation of a lateral. This bid item shall be inclusive of any and all methods and efforts required to locate the lateral for tie-in or relocation of the lateral. Locating methods to be included under this items shall include, but are not limited to, those efforts employing the use of video cameras from within an existing sanitary sewer main or lateral, electronic locating beacons and/or tracers inserted into the sanitary sewer main or lateral, careful excavation as a separate operation from mainline sewer or lateral excavation, the use of dyes to trace the flow of a lateral, or any combination of methods required to accurately locate the lateral. Please refer to the Utility Company's Specifications. If the Company does not have specifications, KYTC's Specifications shall be referenced. This item shall be paid EACH (EA).

**S LATERAL LONG SIDE** This bid item description shall apply to all service lateral installations of every size up to and including 6 inch internal diameter, except those lateral bid items defined as "Special". This item includes the specified piping material, main tap, bends, clean outs, labor, equipment, excavation, backfill, testing, and restoration, at the locations shown on the plans or as directed, in accordance with the specifications and standard drawings, complete and ready for use. This bid item is to pay for service lateral installations where the ends of the lateral connection are on opposite sides of the public roadway. The new lateral must cross the centerline of the public roadway to qualify for payment as a long side lateral. The length of the service lateral is not to be specified. Payment under this item shall not be restricted by a minimum or maximum length. The contractor shall draw his own conclusions as to the length of piping that may be needed. Payment under this item shall include boring, jacking, or excavating across the public roadway for placement. Placement of a service lateral across a private residential or commercial entrance alone shall not be reason to make payment under this item. Private or commercial entrances shall not be considered a public roadway in defining payment under this item. No additional payment will be made for rock excavation or for bedding required in rock excavation. Please refer to the Utility Company's Specifications. If the Company does not have specifications, KYTC's Specifications shall be referenced. This item shall be paid EACH (EA) when complete.

**S LATERAL SHORT SIDE** This bid item description shall apply to all service lateral installations of every size up to and including 6 inch, except those lateral bid items defined as “Special”. This item includes the specified piping material, main tap tee, bends, clean outs, labor, equipment, excavation, backfill, testing, and restoration, at the locations shown on the plans or as directed, in accordance with the specifications and standard drawings, complete and ready for use. This bid item is to pay for lateral installations where both ends of the lateral connection are on the same side of the public roadway, or when an existing lateral crossing a public roadway will remain and is being extended, reconnected, or relocated with all work on one side of the public roadway centerline as shown on the plans. The length of the service lateral is not to be specified and shall not be restricted to any minimum or maximum length. Payment shall be made under this item even if the lateral crosses a private residential or commercial entrance; but, not a public roadway. Private or commercial entrances shall not be considered a public roadway in defining payment under this item. The contractor shall draw his own conclusions as to the length of piping that may be needed. No additional payment will be made for rock excavation or for bedding required in rock excavation. Please refer to the Utility Company’s Specifications. If the Company does not have specifications, KYTC’s Specifications shall be referenced. This item shall be paid EACH (EA) when complete.

**S LINE MARKER** This item is for payment for furnishing and installing a sewer utility line marker as specified by the utility owner specifications and plans. A line marker may consist of a post or monument of whatever materials specified and shall include markings and/or signage on same as specified by plans or specifications. This item shall include all labor, equipment, and materials needed for complete installation of the marker. This item shall be paid EACH (EA) when complete.

**S MANHOLE** Payment under this item is for the installation of new 4 foot interior diameter sanitary sewer manhole. Payment for manholes will be made at the contract unit price each in place complete and ready for use at the locations shown on plans in accordance with specifications and standard drawings. Manholes shall include concrete base, barrel sections, cone section or slab top, steps, excavation, backfilling, air testing, restoration, and cleanup in accordance with the specifications and standard drawings. Payment shall be made under this item regardless of whether the base is to be precast or cast-in-place (doghouse). All materials, except casting, shall be new and unused. An existing casting from an existing abandoned or removed manhole is to be reused and shall be considered incidental to this item. When a new casting is specified, or an existing casting is unavailable, it shall be paid as a separate bid item. Anchoring of casting, new or used, shall be considered incidental to this bid item. No additional compensation will be paid for manhole height variations. No additional payment will be made for rock excavation. Please refer to the Utility Company’s Specifications. If the Company does not have specifications, KYTC’s Specifications shall be referenced. This item shall be paid EACH (EA) when complete.

**S MANHOLE ABANDON/REMOVE** Payment under this item is for the partial removal and/or filling of any sanitary sewer manhole regardless of size or depth that no longer serves any purpose. Payment shall be made regardless of whether the manhole is or is not in conflict with other work. Any manhole requiring partial removal, but not total removal, in order to clear a conflict with other work shall be paid under this item. All manholes partially removed shall be removed to a point at least one foot below final grade, one foot below roadway subgrade, or one foot clear of any other underground infrastructure, whichever is lowest. If partial removal of an abandoned manhole is elected by the contractor, the remaining manhole structure shall be refilled with flowable fill. Payment for disposal of a sanitary sewer manhole will be made under this item only. Please refer to the Utility Company’s

Specifications. If the Company does not have specifications, KYTC's Specifications shall be referenced. This item shall be paid EACH (EA) when complete.

**S MANHOLE ADJUST TO GRADE** Payment under this item is for the adjustment of sanitary sewer casting elevation on all sizes of existing sanitary manholes. This work shall be performed in accordance with the sanitary sewer specifications. Payment shall be made under this bid item regardless of the amount of adjustment necessary to a sanitary sewer manhole casting or diameter of the manhole. Work under this pay item may be as simple as placing a bed of mortar under a casting; but, shall also be inclusive of installation of adjusting rings, and /or addition, removal, or replacement of barrel sections. The existing casting is to be reused unless a new casting is specified on the plans. New casting, when specified, shall be paid as a separate bid item. Anchoring of the casting shall be incidental to this item. Please refer to the Utility Company's Specifications. If the Company does not have specifications, KYTC's Specifications shall be referenced. This item shall be paid EACH (EA) when complete.

**S MANHOLE CASTING STANDARD** Payment under this bid items is for furnishing of a new standard traffic baring casting for sanitary manholes meeting the requirements of the sanitary sewer specifications and standard drawings. Please refer to the Utility Company's Specifications. If the Company does not have specifications, KYTC's Specifications shall be referenced. This item shall be paid EACH (EA) when installed.

**S MANHOLE CASTING WATERTIGHT** Payment under this bid item is for furnishing of a new watertight traffic baring casting for sanitary manholes meeting the requirements of the sanitary sewer specifications and standard drawings. Please refer to the Utility Company's Specifications. If the Company does not have specifications, KYTC's Specifications shall be referenced. This item shall be paid EACH (EA) when installed.

**S MANHOLE RECONSTRUCT INVERT** This bid item is to pay for all labor, equipment, and material for rework of the manhole bench to redirect or eliminate flow, such as when the flow of a pipe or pipes are being removed or redirected. This work will be as specified in the plans, specifications, or directed by the engineer. This work may consist of, but is not limited to, removal of concrete and/or placement of concrete in elimination or redirect of flow. This item shall also include providing and placement of a rubber seal or boot as required by utility specification, standard drawing or plan. The contractor shall draw his own conclusions as to the effort and scope of work needed to comply with the specifications, standard drawings, and plans. No payment shall be made under this bid when MANHOLE TAP EXISTING, or MANHOLE TAP EXISTING ADD DROP are being paid at the same location, as this type of work is included in those items. Please refer to the Utility Company's Specifications. If the Company does not have specifications, KYTC's Specifications shall be referenced. This item shall be paid EACH (EA) when complete.

**S MANHOLE TAP EXISTING** This bid item is to pay for all labor, equipment, and material for coring one opening in an existing manhole base, addition of a rubber seal as specified, and rework of the manhole bench to direct the additional pipe flow. The bid item shall be paid for each core opening added to a single manhole. This bid item shall also include any rework of the existing manhole bench due to the elimination of other existing pipes and flow. This work will be as specified in the plans, specifications, or directed by the engineer. This work may consist of, but is not limited to, removal of concrete and/or placement of concrete in the addition, elimination, or redirect of flow. The contractor shall draw his own conclusions as to the effort and scope of work needed to comply with the

specifications, standard drawings, and plans. Please refer to the Utility Company's Specifications. If the Company does not have specifications, KYTC's Specifications shall be referenced. This item shall be paid EACH (EA) when complete.

**S MANHOLE TAP EXISTING ADD DROP** This bid item is to pay for all labor, equipment, and material for coring one opening in an existing manhole base, addition of a rubber seal as specified, addition of a vertical drop pipe to the outside of the manhole, placement of reinforcing steel and concrete to encase vertical pipe, and rework of the manhole bench to direct the additional pipe flow. The bid item shall be paid for each drop added to a single manhole. This bid item shall also include any rework of the existing manhole bench due to the elimination of other existing pipes and flow. This work will be as specified in the plans, specifications, or directed by the engineer. This work may consist of, but is not limited to, removal of concrete and/or placement of concrete in the addition, elimination, or redirect of flow. The contractor shall draw his own conclusions as to the effort and scope of work needed to comply with the specifications, standard drawings, and plans. Please refer to the Utility Company's Specifications. If the Company does not have specifications, KYTC's Specifications shall be referenced. This item shall be paid EACH (EA) when complete.

**S MANHOLE WITH DROP** Payment under this item is for the installation of new 4 foot interior diameter sanitary sewer manhole with drop. Payment for drop manholes will be made at the contract unit price each in place complete and ready for use at the locations shown on plans in accordance with specifications and standard drawings. Drop manholes shall include concrete base, barrel sections, drop materials, cone section or slab top, steps, excavation, backfilling, air testing, restoration, and cleanup. Payment shall be made under this item regardless of whether the base is to be precast or cast-in-place (doghouse). All materials, except casting, shall be new and unused. An existing casting from an existing abandoned or removed manhole is to be reused and shall be considered incidental to this item. When a new casting is specified, or an existing casting is unavailable, it shall be paid as a separate bid item. Anchoring of casting, new or used, shall be considered incidental to this bid item. No additional compensation will be paid for manhole height variations. No additional payment will be made for rock excavation. Please refer to the Utility Company's Specifications. If the Company does not have specifications, KYTC's Specifications shall be referenced. This item shall be paid EACH (EA) when complete.

**S MANHOLE WITH LINING** Payment under this item is for the installation of new 4 foot interior diameter sanitary sewer manhole with corrosion resistant lining. Payment for manholes will be made at the contract unit price each in place complete and ready for use at the locations shown on plans in accordance with specifications and standard drawings. Manholes shall include concrete base, barrel sections, cone section or slab top, steps, lining, excavation, backfilling, air testing, restoration, and cleanup in accordance with the standard drawings. Payment shall be made under this item regardless of whether the base is to be precast or cast-in-place (doghouse). All materials, except casting, shall be new and unused. An existing casting from an existing abandoned or removed manhole is to be reused and shall be considered incidental to this item. When a new casting is specified, or an existing casting is unavailable, it shall be paid as a separate bid item. Anchoring of casting, new or used, shall be considered incidental to this bid item. No additional compensation will be paid for manhole height variations. No additional payment will be made for rock excavation. Please refer to the Utility Company's Specifications. If the Company does not have specifications, KYTC's Specifications shall be referenced. This item shall be paid EACH (EA) when complete.

**S MANHOLE WITH TRAP** Payment under this item is for the installation of a new manhole with

trap. Payment for trap manholes will be made at the contract unit price each in place complete and ready for use at the locations shown on plans in accordance with specifications and standard drawings. Trap manholes shall include concrete base, manhole structure and trap materials, cone section or slab top, steps, excavation, backfilling, air testing, restoration, and cleanup. All materials, except casting, shall be new and unused. Payment shall be made under this item regardless of whether the base is to be precast or cast-in-place (doghouse). An existing casting from an existing abandoned or removed manhole is to be reused and shall be considered incidental to this item. When a new casting is specified, or an existing casting is unavailable, it shall be paid as a separate bid item. Anchoring of casting, new or used, shall be considered incidental to this bid item. No additional compensation will be paid for manhole height variations. No additional payment will be made for rock excavation. Please refer to the Utility Company's Specifications. If the Company does not have specifications, KYTC's Specifications shall be referenced. This item shall be paid EACH (EA) when complete.

**S PIPE** This description shall apply to all PVC and ductile iron gravity sewer pipe bid items of every size and type 8 inches internal diameter and larger, except those bid items defined as "Special". This item includes the pipe specified by the plans and specifications, all fittings (including, but not limited to, tap tees and couplings for joining to existing similar or dissimilar pipes), polyethylene wrap (if required by specification), labor, equipment, excavation, bedding, restoration, pressure or vacuum testing, temporary testing materials, video inspection, backfill, and etc., required to install the specified new pipe and new fittings at the locations shown on the plans, or as directed, in accordance with the specifications and standard drawings complete and ready for use. This bid item shall include material and placement of flowable fill under existing and proposed pavement, and wherever specified on the plans or in the specifications. No additional payment will be made for rock excavation. Measurement of quantities under this item shall be through fittings and encasements to a point at the outside face of manhole barrels, or to the point of main termination at dead ends or lamp holes. Carrier pipe placed within an encasement shall be paid under this item and shall include casing spacers and end seals. Please refer to the Utility Company's Specifications. If the Company does not have specifications, KYTC's Specifications shall be referenced. This item shall be paid LINEAR FEET (LF).

**S PIPE POINT REPAIR** This item is to be used to pay for repair of short lengths of existing sanitary sewer pipe that, through prior video inspection or other means, are known to have pre-existing failure. Pipe Point Repair may be needed in preparation for installation of cured-in-place-pipe (CIPP) lining or other instances where failure is known and repair is prudent. The size of pipe shall not be defined in separate bid items. All diameter sizes of point repair shall be paid under this one item. The materials to be used to make the repair shall be as defined on the plans or in the specifications. This bid item shall include all excavation, pipe materials, joining materials to connect old and new pipe, bedding, and backfill to complete the repair at the locations shown on the plans or as directed by the engineer, complete and ready for use. This bid item shall include bypass pumping when required. Measurement shall be from contact point to contact point of old and new pipe. Please refer to the Utility Company's Specifications. If the Company does not have specifications, KYTC's Specifications shall be referenced. This item shall be paid LINEAR FEET (LF).

**S PUMP STATION** This item is for payment for installation of sanitary pump stations including above or below ground structure for housing of the pumps. This item shall include all pumps, piping, fittings, valves, electrical components, building materials, concrete, any other appurtenances, labor, equipment, excavation, and backfill, to complete the pump station installation as required by the plans, standard drawings, and specifications, complete and ready for use. Please refer to the Utility Company's Specifications. If the Company does not have specifications, KYTC's Specifications shall



be referenced. This item shall be paid LUMP SUM (LS) for each when complete.

**S STRUCTURE ABANDON** This item is to be used to pay for abandonment of larger above or below ground sewer structures such as air release/vacuum valve vaults, pump stations, tanks, etc. Payment under this time shall not be limited to size or scope; however structures with connecting pipes of 2 inches or less shall not be paid under this item; but, shall be considered incidental to sewer construction, (i.e., abandonment of standard air release/vacuum valves up to and including 2 inches would not be paid under this item). Payment under this item shall include all labor, equipment, and compacted fill or flowable fill for abandonment of the structure in place and restoration complete. No separate bid items will be established for size or structure variations. Please refer to the Utility Company's Specifications. If the Company does not have specifications, KYTC's Specifications shall be referenced. This item shall be paid EACH (EA) when complete.

**S STRUCTURE REMOVAL** This item is to be used to pay for removal of larger above or below ground sewer structures such as air release/vacuum valve vaults, pump stations, tanks, and etc. Payment under this time shall not be limited to size or scope; however, structures with connecting pipes of 2 inches or less shall not be paid under this item; but, shall be considered incidental to sewer construction, (i.e., removal of standard air release/vacuum valves and their structure up to and including 2 inches would not be paid under this item). Payment under this item shall include all labor, equipment, and compacted backfill for removal of the structure and restoration complete. No separate bid items will be established for size or structure variations. Please refer to the Utility Company's Specifications. If the Company does not have specifications, KYTC's Specifications shall be referenced. This item shall be paid EACH (EA) when complete.

**CONTRACT SPECIFICATIONS**  
**KY 44 OLD MILL ROAD**  
**KDOH FORCE MAIN RELOCATION**  
**FOR**  
**CITY OF MT. WASHINGTON**  
**Mt. Washington, Bullitt County, Kentucky**



**Kentucky Engineering Group, PLLC**  
**P.O. Box 1034**  
**Versailles, Kentucky 40383**

**June, 2019**  
**KEG Project No. 19012**

# TABLE OF CONTENTS

PAGE

TOC-1

---

## **DIVISION 2 - SITE WORK**

SECTION -01025 – MEASUREMENT AND PAYMENT .....	1-5
SECTION 02220 – EXCAVATION.....	1-4
SECTION 02310 – PIPE AND FITTINGS FOR SANITARY SEWERS.....	1-13
SECTION 02226 – TRENCHING, BACKFILLING AND COMPACTING .....	1-3
SECTION 02502 – RESTORATION OF SURFACES.....	1-5

01025-1

## **SECTION 01025**

### **MEASUREMENT AND PAYMENT**

#### **PART 1 - GENERAL**

##### **1.01 WORK INCLUDED**

The Contractor shall furnish all necessary labor, machinery, tools, apparatus, equipment, materials, equipment, service, other necessary supplies and perform all work, including all excavation and backfilling (without additional compensation, except where specifically set out in these specifications) at the unit or lump sum prices for the following items.

##### **1.02 PROGRESS AND PAYMENTS SCHEDULES**

- A. Within ten (10) days after the date of formal execution of the AGREEMENT, the Contractor shall prepare and submit to the Engineer, for approval, a construction schedule which depicts the Contractor's plan for completing the contract requirements and show work placement in dollars versus contract time. The Contractor's construction schedule must be approved by the Engineer before any payments will be made on this contract.
- B. Within ten (10) days after the date of formal execution of the CONTRACT AGREEMENT, the Contractor shall prepare and submit to the Engineer, for approval, a periodic estimate which depicts the Contractor's cost for completing the contract requirements and show by major unit of the project work, the Contractor's dollar value for the material and the labor (two separate amounts) to be used as a basis for the periodic payments. The Contractor's periodic estimate must be approved by the Engineer before any payments will be made on this contract.
- C. The Engineer's decision as to sufficiency and completeness of the Contractor's construction schedule and periodic estimate will be final.
- D. The Contractor must make current, to the satisfaction of the Engineer, the construction schedule and periodic estimate each time he requests a payment on this contract.
- E. The Contractor's construction schedule and periodic estimate must be maintained at the construction site available for inspection and shall be revised to incorporate approved change orders as they occur.
- F. When the Contractor requests a payment on this contract, it must be on the approved periodic estimate and be current. Further, the current periodic estimate and construction schedule (both updated and revised) shall be submitted for review and approval by the Engineer before monthly payments will be made by the Owner. The Contractor shall submit six (6) current copies of each (periodic estimate and construction schedule) when requesting payment.
- G. Change orders to the construction contract must comply with DOW Procurement Guidance for Construction and Equipment contracts. All change orders exceeding \$100,000 shall require costs, pricing and certification per the DOW Procurement Guidance for Construction and Equipment contracts.

##### **1.03 CONDITIONS FOR PAYMENT**

- A. The Owner will make payments for acceptable work in place and materials properly stored on-site. The value of payment shall be as established on the approved construction schedule and

01025-2

periodic estimate, EXCEPT the Owner will retain five percent (5%) of the work in place and a percentage as hereinafter listed for items properly stored or untested.

- B. No payment will be made for stored materials unless a proper invoice form the supplier is attached to the pay request. Further, no item whose value is less than \$1,000 will be considered as stored materials for pay purposes.
- C. Payment for pipeline items shall be limited to eighty percent (80%) of the bid price until the pipeline items have been tested and clean up has been completed and accepted by the Engineer.
- D. Payment for equipment items shall be limited to eighty-five percent (85%) of their scheduled value (materials portion only) until they are set in place. Eighty-five percent (85%) for stored materials and equipment shall be contingent on proper on-site storage as recommended by the manufacturer or required by the Engineer.
- E. Payment for equipment items set in place shall be limited to ninety percent (90%) of their scheduled value until they are ready for operation and have been certified by the manufacturer. Ninety percent (90%) payment for installed equipment shall be contingent on proper routine maintenance of the equipment in accordance with the manufacturer's recommendations.
- F. Payment for equipment items set in place and ready for operation shall be limited to ninety-five percent (95%) of their scheduled value until all acceptance tests have been completed and the required manufacturer's pre-startup operator's training has been completed.
- G. Payment for the labor portion of equipment items will be subject only to the degree of completeness and the appropriate retainage.
- H. The retainage shall be an amount equal to 5% of said estimate. The retainage on the equipment items shall be 10% as defined hereinbefore.
- I. If at any time thereafter when the progress of the WORK is not satisfactory or determine that the Contractor is not making satisfactory progress, additional amounts may be retained.

#### **1.04 CLAIMS FOR EXTRA WORK**

- A. If the Contractor claims that any instructions by Drawings or otherwise involve extra cost, he shall give the Engineer written notice of said claim within ten (10) days after the receipt of such instructions and, in any event before proceeding to execute the work, stating clearly and in detail the basis of his claim or claims. No such claim shall be valid unless so made.
- B. Claims for additional compensation for extra work, due to alleged errors in spot elevations, contour lines or bench marks, will not be recognized unless accompanied by certified survey data, made prior to the time the original ground was disturbed, clearly showing that errors exist which resulted, or would result, in handling more material or performing more work than would reasonably be estimated from the Drawings and topographical maps issued.
- C. Any discrepancies which may be discovered between actual conditions and those represented by the topographical maps and Drawings shall at once be reported to the Engineer, and work shall not proceed, except at the Contractor's risk, until written instructions have been received by him from the Engineer.
- D. If, on the basis of the available evidence, the Engineer determines that an adjustment of the Contract Price or time is justifiable, the procedure shall then be as provided herein for "Changes in the Work".

01025-3

- E. By execution of this Contract, the Contractor warrants that he has visited the site of the proposed work and fully acquainted himself with the conditions there existing relating to construction and labor, and that he fully understands the facilities, difficulties and restrictions attending the execution of the work under this Contract. The Contractor further warrants that he has thoroughly examined and is familiar with the Drawings, Specifications and all other documents comprising the Contract. The Contractor further warrants that by execution of this Contract his failure when he was bidding on this Contract to receive or examine any form, instrument or document, or to visit the site and acquaint himself with conditions there existing, in no way relieves him from any obligation under the Contract, and the Contractor agrees that the Owner shall be justified in rejecting any claim based on facts regarding which he should have been on notice as a result thereof.

#### **1.05 DETERMINATION OF THE VALUE OF EXTRA (ADDITIONAL) OR OMITTED WORK**

- A. The value of extra (additional) or omitted work shall be determined in one or more of the following ways:
1. On the basis of the actual cost of all the items of labor (including on-the-job supervision), materials and use of equipment, plus a maximum 20% for added work or a minimum 20% for deleted work which shall cover the Contractor's general supervision, overhead and profit. In case of subcontracts, the sum of total overhead amounts of the subcontractors and Contractor, plus total profit amounts for the subcontracts and Contractor shall not exceed 25% of the cost. Subcontractors shall be limited to 15% and Contractors shall be limited to 10% for combined overhead and profit. The cost of labor shall include required insurance, taxes and fringe benefits. Contractor to provide detailed breakdown of all cost as justification of change in work. Equipment costs shall be based on current rental rates in the areas where the work is being performed, but in no case shall such costs be greater than the current rates published by the Associated Equipment Distributors, Chicago, Illinois.
  2. By estimate and acceptance in a lump sum.
  3. By unit prices named in the Contract or subsequently agreed upon.
- B. Provided, however, that the cost or estimated cost of all extra (additional) work shall be determined in advance of authorization by the Engineer and approved by the Owner.
- C. All extra (additional) work shall be executed under the conditions of the original Contract. Any claim for extension of time shall be adjusted according to the proportionate increase or decrease in the final total cost of the work unless negotiated on another basis.
- D. Except for over-runs in contract unit price items, no extra (additional) work shall be done except upon a written change Order from the Engineer, and no claim on the part of the Contractor for pay for extra (additional) work shall be recognized unless so ordered in writing by the Engineer.

### **PART 2 – PRODUCTS**

#### **2.01 CONNECTION TO EXISTING FORCE MAIN**

Payment is for furnishing and installing a connection to an existing manhole at the contract unit price each, based on the line size as indicated on the Bid Schedule. This is to be paid at the contract unit price, complete in place, which shall include compensation for coring, coupling, sealing one full length of pipe, materials, hauling, tapping, excavation, shoring, sheeting, bedding, forming and placing

01025-4

(constructing) concrete cradle, backfilling, cleanup, testing, and all other items necessary for a complete installation.

## **2.02 CUT AND CAP EXISTING SEWER**

Payment is for cutting and capping existing sewer, based on the size as indicated on the Bid Schedule. This is to be paid at the contract unit price each, complete in place, which shall include compensation for concrete, cutting pipe, materials, equipment, excavation (excluding rock excavation), backfilling, cleanup, restoration, and all other items necessary for a complete capping.

## **2.03 FORCE MAIN**

- A. Payment for installing the force main will be made at the contract unit price per linear foot, complete in place, which shall include compensation for furnishing pipe, fittings, trenching (including rock excavation), earth, sand or Class I material bedding, thrustblocking, earth backfill, fittings, crushed stone pavement replacement, boring without casing under bituminous and concrete drives, sidewalk repair or replacement, disinfection, copper tracing wire and identification tape, testing and all appurtenances required. The quantity of force main to be paid for shall be the length of the completed line as measured along its centerline without any deduction for lengths of fittings, valves or other appurtenances.
- B. Payment for crushed stone or bituminous pavement replacement and concrete surface replacement is included in this pay item and considered incidental to the construction and shall include furnishing and laying same in accordance with the specifications including concrete sub-slab and gravel backfill under pavement.
- C. **All sewer force main must be laid contiguously beginning at the connection point and extending to the pump station.**

## **2.04 FORCE MAIN CONCRETE ENCASEMENT**

Payment is for furnishing and installing a concrete encasement of the sewage force main at the contract unit price per linear foot as indicated on the Bid Schedule. This is to be paid at the contract unit price, complete in place, which shall include compensation for steel casing pipe, end seals, all other materials, hauling, tapping, excavation, shoring, sheeting, bedding, forming and placing (constructing) concrete cradle, backfilling, cleanup, testing, and all other items necessary for a complete installation.

## **PART 3 - EXECUTION**

### **3.01 PAY ITEMS**

- A. The pay items listed herein before refer to the items listed in the Bid Schedule and cover all of the pay items under the base bid for this contract.
- B. Any and all other items of work listed in the specifications or shown on the Contract Drawings for this contract shall be considered incidental to and included in those pay items.

### **3.02 QUANTITIES OF ESTIMATE**

- A. Wherever the estimated quantities of work to be done and materials to be furnished under this Contract are shown in any of the documents, including the Bid Proposal, they are given for use in comparing bids and the right is especially reserved except as herein otherwise specifically limited, to increase or diminish them as may be deemed reasonably necessary or desirable by the

01025-5

Owner to complete the work contemplated by this Contract, and such increase or diminution shall not give cause for claims or liability for damages. The Engineer will not be financially responsible for any omissions from the Contract Documents and therefore not included by the Contractor in his proposal.

- B. Aerial photographs utilized for plan sheets in the Contract Documents are indicated at an approximate scale and shall not be scaled for quantity take-offs. The pipeline quantities listed in the Bid Schedule are given for use in comparing bids and may not be the actual quantities to be installed. It is the Contractor's responsibility to field verify the length and quantities of pipeline to be installed prior to the ordering of materials. Payment on unit price contracts are based on actual quantities installed. The Owner or Engineer will not be financially responsible for any shortage of pipe or overrun of pipe ordered for the pipeline quantities.
- C. The actual quantities of all materials to be used for this project shall be field verified prior to the Contractor ordering the necessary materials. The quantity listed in the bid schedule is given for use in comparing bids and may increase or diminish as may be deemed necessary or as directed by the Owner. Any such increase or diminution shall not give cause for claims or liability for damages. The Engineer or Owner will not be financially responsible for any charges incurred for restocking of materials ordered.

- END OF SECTION -



02220-1

## SECTION 02220

### EXCAVATION

#### PART 1 - GENERAL

##### 1.01 WORK INCLUDED

All excavation for the project is unclassified excavation. No separate payment shall be made for rock excavation.

#### PART 2 - PRODUCTS

Not used.

#### PART 3 - EXECUTION

##### 3.01 EXCAVATION FOR TRENCHES

- A. If the foundation is good firm earth and the machine excavation has been accomplished, the remainder of the material shall be excavated by hand and the earth pared or molded to give full support to the lower quadrant of the barrel of each pipe. Where bell and spigot pipe are involved, bell holes shall be excavated during this latter operation to prevent the bells from being supported on undistributed earth. If for any reason the machine excavation in earth is carried below an elevation that will permit the type of bedding in undistributed earth, then a layer of granular material shall be placed so that the lower quadrant of the pipe will be securely bedded in the granular fill as described in Section 02610, Part 3.
- B. If the foundation is rock and the excavation has been undercut as set out hereinbefore, a bed of No. 9 crushed stone aggregate shall be placed to provide continuous support for the lower quadrant of the pipe.
- C. Trenches shall be of sufficient width to provide free working space on each side of the pipe and to permit proper backfilling around the pipe, but unless specifically authorized by the Engineer, trenches shall in no case be excavated or permitted to become wider than 2'-6" plus the nominal diameters of the pipe at the level of or below the top of pipe. Trenches cut in roads and streets shall not exceed a maximum width of 3'-6" plus the nominal diameters of the pipe at the level of the road or street surface.
- D. All excavated materials shall be placed a minimum of 2 feet back from the edge of the trench.
- E. Unless specifically directed otherwise by the Engineer, not more than 500 feet of trench shall be opened ahead of the pipe laying work of any one crew, and not more than 500 feet of open ditch shall be left behind the pipe laying work of any one crew. Watchmen or barricades, lanterns and other such signs and signals as may be necessary to warn the public of the dangers in connection with open trenches, excavations and other obstructions, shall be provided by and at the expense of the Contractor.
- F. When so required, or when directed by the Engineer, only one-half of street crossings and road crossings shall be excavated before placing temporary bridges over the side excavated, for the convenience of the traveling public. All backfilled ditches shall be maintained in such manner that they will offer no hazard to the passage of traffic. The convenience of the traveling public and the property owners abutting the improvements shall be taken into consideration. All public or private drives shall be promptly backfilled at the direction of the Engineer.

02220-2

- G. Where existing drainage ditches coincide with the proposed water main alignment, the Contractor shall re-establish the drainage ditch after the water main has been laid and properly backfilled. The drainage ditch shall be of equal size as the previously existing one and free of any restrictions which might impede flow.

### **3.02 SHORING, SHEETING, AND BRACING OF EXCAVATION**

- A. Where unstable material is encountered or where the depth of excavation in earth exceeds five (5) feet, the sides of the trench or excavation shall be supported by substantial sheeting, bracing, and shoring, or the sides sloped to the angle of repose. Sloping the sides of the ditch to the angle will not be permitted in streets, roads, narrow rights-of-way or other constricted areas unless otherwise specified. The design and installation of all sheeting, sheet piling, bracing and shoring shall be based on computations of pressure exerted by the materials to be retained under obtaining conditions. Adequate and proper shoring of all excavations shall be the entire responsibility of the Contractor; however, the Engineer may require the submission of shoring plans (accompanied by supporting computations) for approval prior to the Contractor undertaking any portion of the work. The standards of the Federal Occupational Safety and Health Act and the Kentucky Labor Cabinet shall be followed.
- B. Foundations, adjacent to where the excavation is to be made below the depth of the existing foundation, shall be supported by shoring, bracing or underpinning as long as the excavation shall remain open, or thereafter if required to insure the stability of the structure supported by the foundation, and the Contractor shall be held strictly responsible for any damage to said foundations.
- C. Solid sheeting will be required for wet or unstable material. It shall consist of continuous vertical sheet piling of timber or steel with suitable wales and braces.
- D. Care shall be taken to avoid excessive backfill loads on the completed pipelines and the trench width requirements at the level of the crown of the pipe and at the level of a road or street be strictly observed.
- E. Trench sheeting shall not be removed until sufficient backfill has been placed to protect the pipe.
- F. All sheeting, planking, timbering, bracing and bridging shall be placed, renewed and maintained as long as is necessary.

### **3.03 REMOVAL OF WATER**

- A. The Contractor, at his own expense, shall provide adequate facilities for promptly and continuously removing water from all excavation.
- B. To ensure proper conditions at all times during construction, the Contractor shall provide and maintain ample means and devices (including spare units kept ready for immediate use in case of breakdowns) with which to remove promptly and dispose properly of all water entering trenches and other excavations. Such excavation shall be kept dry until the structures, pipes, and appurtenances to be built therein have been completed to such extent that they will not be floated or otherwise damaged.
- C. All water pumped or drained from the work shall be disposed of in a suitable manner without undue interference with other work, damage to pavements, other surfaces, or property. Suitable temporary pipes, flumes, or channels shall be provided for water that may flow along or across the site of the work.

02220-3

- D. If necessary, the Contractor shall dewater the excavations by means of an efficient drainage wellpoint system which will drain the soil and prevent saturated soil from flowing into the excavation. The wellpoints shall be designed especially for this type of service. The pumping unit shall be designed for use with the wellpoints, and shall be capable of maintaining a high vacuum and of handling large volumes of air and water at the same time.
- E. The installation of the wellpoints and pump shall be done under the supervision of a competent representative of the manufacturer. The Contractor shall do all special work such as surrounding the wellpoints with sand or gravel or other work which is necessary for the wellpoint system to operate for the successful dewatering of the excavation.
- F. The Contractor shall at all times during construction provide and maintain means and devices with which to promptly dispose of all water entering the excavations or other parts of the work and shall keep said excavations dry until the structures to be built therein are complete. No concrete shall be placed in water nor shall water be allowed to rise over structures if there is danger of floatation or of setting up unequal pressures in the concrete, until the concrete has set at least twenty four (24) hours and any danger of floatation has been removed.
- G. The Contractor shall dispose of water from the work in a suitable manner without damage to adjacent property or sewers. No water shall be drained into work built or under construction. No sanitary sewer shall be used for the disposal of trench water.

### **3.04 DISPOSITION OF EXCAVATED MATERIAL**

Material excavated for pipe lines and structures not suitable or needed for backfilling purposes, shall be disposed of by the Contractor at his own expense in a manner satisfactory to the Engineer.

### **3.05 UNAUTHORIZED EXCAVATION**

Whenever the excavation is carried beyond or below the required lines and grades, the Contractor, at his own expense, shall refill said excavated space with suitable material in a manner approved by the Engineer.

### **3.06 EXISTING UTILITIES AND OTHER OBSTRUCTIONS**

Prior to the commencement of construction on the project, the Contractor shall contact the utility companies whose lines, above and below ground, may be affected during construction and verify the locations of the utilities as shown on the Contract Drawings. The Contractor shall ascertain from said companies if he will be allowed to displace or alter, by necessity, those lines encountered or replace those lines disturbed by accident during construction, or if the companies themselves are only permitted by policy to perform such work. If the Contractor is permitted to perform such work, he shall leave the lines in as good condition as were originally encountered and complete the work as quickly as possible. All such lines or underground structures damaged or molested in the construction shall be replaced at the Contractor's expense, unless, in the opinion of the Engineer, such damage was caused through no fault of the Contractor.

### **3.07 FINAL CLEANUP AND RESTORATION**

Unless specifically approved by the Owner and Engineer, **cleanup of disturbed areas shall be kept current with construction** and restoration efforts by the contractor initiated **immediately** and areas not remain **unprotected** for more than **seven 7 days**. Any large rocks, stones or debris shall be removed from the site, and shall not be a burden to the property owner(s) and/or adjacent properties. The contractor may windrow or track-in the excavated material over the trench prior to final cleanup to allow

02220-4

for and to assist in the initial settlement of the trench. All disturbed areas must be seeded at least with a temporary seed mix if for some reason the area cannot be permanently seeded within two (2) weeks.

- END OF SECTION -

02226-1

## SECTION 02226

### TRENCHING, BACKFILLING AND COMPACTING

#### PART 1 GENERAL

##### 1.01 SUMMARY

- A. This Section includes excavation and backfill as required for pipe installation or other construction in the trench, and removal and disposal of water, in accordance with the applicable provisions of the Section entitled "Earthwork" unless modified herein.

#### PART 2 PRODUCTS

NOT USED

#### PART 3 EXECUTION

##### 3.01 EXCAVATION

- A. The trench excavation shall be located as shown on the Contract Drawings or as specified. Under ordinary conditions, excavation shall be by open cut from the ground surface. Where the depth of trench and soil conditions permit, tunneling may be required beneath cross walks, curbs, gutters, pavements, trees, driveways, railroad tracks and other surface structures. No additional compensation will be allowed for such tunneling over the price bid for open cut excavation of equivalent depths below the ground surface unless such tunnel excavation is specifically provided for in the Contract Documents.
- B. Trenches shall be excavated to maintain the depths as shown on the Contract Drawings or as specified for the type of pipe to be installed.
- C. The alignment and depth shall be determined and maintained by the use of a string line installed on batter boards above the trench, a double string line installed along side of the trench or a laser beam system.
- D. The minimum width of trench excavation shall be 6-inches on each side of the pipe hub for 21-inch diameter pipe and smaller and 12-inches on each side of the pipe hub for 24-inch diameter pipe and larger.
- E. Trenches shall not be opened for more than 300 feet in advance of pipe installation nor left unfilled for more than 100 feet in the rear of the installed pipe when work is in progress without the consent of the Engineer. Open trenches shall be protected and barricaded as required.
- F. Bridging across open trenches shall be constructed and maintained where required.

##### 3.02 SUBGRADE PREPARATION FOR PIPE

- A. Where pipe is to be laid on undisturbed bottom of excavated trench, mechanical excavation shall not extend lower than the finished subgrade elevation at any point.
- B. Where pipe is to be laid on special granular material the excavation below subgrade shall be to the depth specified or directed. The excavation below subgrade shall be refilled with special granular material as specified or directed, shall be deposited in

02226-2

layers not to exceed 6 inches and shall be thoroughly compacted prior to the preparation of pipe subgrade.

- C. The subgrade shall be prepared by shaping with hand tools to the contour of the pipe barrel to allow for uniform and continuous bearing and support on solid undisturbed ground or embedment for the entire length of the pipe.
- D. Pipe subgrade preparation shall be performed immediately prior to installing the pipe in the trench. Where bell holes are required they shall be made after the subgrade preparation is complete and shall be only of sufficient length to prevent any part of the bell from becoming in contact with the trench bottom and allowing space for joint assembly.

### **3.03 STORAGE OF MATERIALS**

- A. Traffic shall be maintained at all times in accordance with the applicable Highway Permits. Where no Highway Permit is required at least one-half of the street must be kept open for traffic.
- B. Where conditions do not permit storage of materials adjacent to the trench, the material excavated from a length as may be required, shall be removed by the Contractor, at his cost and expense, as soon as excavated. The material subsequently excavated shall be used to refill the trench where the pipe had been built, provided it be of suitable character. The excess material shall be removed to locations selected and obtained by the Contractor.
  - 1. The Contractor shall, at his cost and expense, bring back adequate amounts of satisfactory excavated materials as may be required to properly refill the trenches.
- C. If directed by the Engineer, the Contractor shall refill trenches with select fill or other suitable materials and excess excavated materials shall be disposed of as spoil.

### **3.04 REMOVAL OF WATER AND DRAINAGE**

- A. The Contractor shall at all times provide and maintain proper and satisfactory means and devices for the removal of all water entering the trench, and shall remove all such water as fast as it may collect, in such manner as shall not interfere with the prosecution of the work.
- B. The removal of water shall be in accordance with the Section entitled "Earthwork".

### **3.05 PIPE EMBEDMENT**

- A. All pipe shall be protected from lateral displacement and possible damage resulting from superimposed backfill loads, impact or unbalanced loading during backfilling operations by being adequately embedded in suitable pipe embedment material. To ensure adequate lateral and vertical stability of the installed pipe during pipe jointing and embedment operations, a sufficient amount of the pipe embedment material to hold the pipe in rigid alignment shall be uniformly deposited and thoroughly compacted on each side, and back of the bell, of each pipe as laid.
- B. Concrete cradle and encasement of the class specified shall be installed where and as shown on the Contract Drawings or ordered by the Engineer. Before any concrete is placed, the pipe shall be securely blocked and braced to prevent movement or flotation. The concrete cradle or encasement shall extend the full width of the trench as excavated unless otherwise authorized by the Engineer. Where concrete is to be placed

02226-3

in a sheeted trench it shall be poured directly against sheeting to be left in place or against a bond-breaker if the sheeting is to be removed.

- C. Embedment materials placed above the centerline of the pipe or above the concrete cradle to a depth of 12 inches above the top of the pipe barrel shall be deposited in such manner as to not damage the pipe. Compaction shall be as required for the type of embedment being installed.

### **3.06 BACKFILL ABOVE EMBEDMENT**

- A. The remaining portion of the pipe trench above the embedment shall be refilled with suitable materials compacted as specified.
  - 1. Where trenches are within the ditch-to-ditch limits of any street or road or within a driveway or sidewalk, or shall be under a structure, the trench shall be refilled in horizontal layers not more than 8 inches in thickness, and compacted to obtain 95% maximum density, and determined as set forth in the Section entitled "Earthwork".
  - 2. Where trenches are in open fields or unimproved areas outside of the ditch limits of roads, the backfilling may be by placing the material in the trench and mounding the surface.
  - 3. Hand tamping shall be required around buried utility lines or other subsurface features that could be damaged by mechanical compaction equipment.
- B. Backfilling of trenches beneath, across or adjacent to drainage ditches and water courses shall be done in such a manner that water will not accumulate in unfilled or partially filled trenches and the backfill shall be protected from surface erosion by adequate means.
  - 1. Where trenches cross waterways, the backfill surface exposed on the bottom and slopes thereof shall be protected by means of stone or concrete rip-rap or pavement.
- C. All settlement of the backfill shall be refilled and compacted as it occurs.
- D. Temporary pavement shall be placed as specified in the Section entitled "Restoration of Surfaces".

-END OF SECTION-

02310-1

## SECTION 02310

### PIPE AND FITTINGS FOR SANITARY SEWERS

#### PART 1 - GENERAL

##### 1.01 WORK INCLUDED

The Contractor shall furnish all labor, material, and equipment necessary to install gravity sewer piping together with all appurtenances as shown and detailed on the Drawings and specified herein.

##### 1.02 RELATED WORK

- A. Section 02222 - Excavation.
- B. Section 02226 - Trench Bedding and Backfilling.
- C. Section 02330 - Manholes, Frames and Covers.
- D. Section 02340 - Encasement Pipe.

#### PART 2 - PRODUCTS

##### 2.01 PIPE AND FITTINGS

- A. Ductile Iron (DI) Pipe:
  - 1. Ductile iron pipe shall conform to ANSI A21.50 (AWWA C150) and ANSI A21.51 (AWWA C151). The pipe shall be designed for an internal working pressure of 150 psi and external loading based on flat bottom trenches without blocks and untamped backfill laying conditions. The pipe shall conform to the following minimum thickness classes: pipe size 4 inches and smaller, Class 51; pipe size 6 inches and larger, Class 50.
  - 2. Fittings shall be Class 250 ductile iron fittings in accordance with ANSI A 21.10 (AWWA C 110).
  - 3. Joints shall be push-on type, mechanical joint type conforming to ANSI A21.11 (AWWA C 111) or restrained joint type. Unless specifically required at designated locations by the Drawings, the type of joint used is optional. Restrained joints shall be TR-Flex type as manufactured by U.S. Pipe and Foundry Co., or approved equal.
    - a. Push-on joints shall have an annular recess in the pipe socket to accommodate a single rubber gasket. Plain ends shall be suitably beveled to permit easy entry into the bell. The gasket and annular recess of the socket shall be so designed and shaped that the gasket is located in place against displacement as the joint is assembled.
    - b. Mechanical joints shall be bolted and of the stuffing box type and shall consist of a bell with exterior flange and interior recess for the sealing gasket, a pipe or fitting plain end, a sealing gasket, a follower gland, tee-head bolts and hexagon nuts.

19012/6-2019

PIPE AND FITTINGS FOR SANITARY SEWERS



02310-2

- c. Restrained joints for a 4" through 54" push-on joint pipe installation is required and indicated in the project plans or specifications, restrained push-on joint pipe and fittings utilizing ductile iron components shall be provided.

Restrained joint pipe shall be ductile iron manufactured in accordance with the requirements of ANSI/AWWA C151/A21.51. Push-on joints for such pipe shall be in accordance with ANSI/AWWA C111/A21.11. Pipe thickness shall be designed in accordance with ANSI/AWWA C150/A21.50, and shall be based on laying conditions and internal pressures as stated in the project plans and specifications. Pipe shall be U.S. Pipe TR FLEX pipe or equal.

Restrained joint fittings shall be ductile iron in accordance with applicable requirements of ANSI/AWWA C110/A21.10 with the exception of the manufacturer's proprietary design dimensions. Push-on joints for such fittings shall be in accordance with ANSI/AWWA C111/A21.11. Fittings shall be U.S. Pipe TR FLEX fittings or equal.

Cement mortar lining and seal coating for pipe and fittings, where applicable, shall be in accordance with ANSI/AWWA C104/A21.4. Bituminous outside coating shall be in accordance with ANSI/AWWA C151/A21.51 for pipe and ANSI/AWWA C110/A21.10 for fittings.

Restrained push-on joints for pipe and fittings shall be designed for a water working pressure of 350 psi in sizes 4" through 24" and 250 psi for sizes 30" through 54".

Restrained push-on joint pipe and fittings shall be capable of being deflected after assembly.

4. All ductile iron pipe and fittings shall have the manufacturer's outside coal tar or asphaltic base coating and a polyethylene lining complying with ANSI/ASTM D1248 on the inside.
5. The inside lining material for pipe and fittings shall be virgin polyethylene complying with ANSI/ASTM D1248, compounded with an inert filler and with sufficient carbon black to resist ultra-violet rays during aboveground storage of the pipe and fittings. The polyethylene shall be bonded to the interior of the pipe of fitting by heat.

All surface areas to be lined shall be blast cleaned comparable to the requirements of SSPC-SP6 or NACE #3.

02310-3

Polyethylene linings shall cover the inner surface of pipe and fittings as shown and described below. In pipe utilizing push-on gaskets, the lining shall extend from the spigot end through the socket to the edge of the gasket sealing area. In mechanical joint pipe the lining shall extend from the spigot end through the socket to the edge of the gauging ring. The lining in fittings shall cover the interior surfaces including the socket areas as defined above.

Lining in piping and in the fittings shall be 40 mils nominal thickness. Minimum lining thickness shall be 30 mils.

6. Pipe shall be furnished in lengths of 16, 16.5, 18 and 20 feet nominal laying lengths. The weight of any single pipe shall not be less than the tabulated weight by more than 5 percent for pipe 12 inches or smaller in diameter, not by more than 4 percent for pipe larger than 12 inches in diameter.
7. The net weight, class or nominal thickness and sampling period shall be marked on each pipe. The pipe shall also be marked to show that it is ductile iron.

B. Polyvinyl Chloride (PVC) Gravity Sewer:

1. Polyvinyl chloride (PVC) pipe and fittings, 4 to 15 inch in diameter, for gravity sewers shall conform to the requirements of ASTM specification D-3034 (SDR 35), current approval, "Type PSM Polyvinyl Chloride (PVC) Sewer Pipe and Fittings."
2. Polyvinyl chloride (PVC) pipe and fittings, 18 inch to 27 inch in diameter shall conform to the requirements of ASTM specification F679, current approval.
3. Joints for PVC pipe shall be of the elastomeric gasket type and installed per the manufacturer's recommendations. Pipe that has been field cut must be beveled for insertion into gasketed joints. Bevel can be made with hand or power tool. In either case, the finished bevel should be the same as the factory bevel. All pipe shall be provided with home marks to insure proper gasket seating. Gasket material shall comply with the physical requirements specified in ASTM D-1869, C-361, C-433, current approval.
4. Fittings for service connections shall be of the factory made inline type conforming with the requirements of ASTM specification D-3034, current approval. Saddle type fittings shall not be used.
5. PVC sewer pipe shall be supplied in standard lengths of at least 12'6". Longer lengths are permitted.
6. PVC sewer pipe shall be marked with the manufacturer's name, production lot number, ASTM designation, PVC, and the nominal diameter.
7. All underground place piping shall have a metallic tape laid 2 foot above the pipe. The tape shall have the word "Caution" printed on it and shall identify the pipe use. Product shall be Seton Name Plate Corp., New Haven, CT, No. 210, or equal.
8. Five copies of directions for handling and installing shall be furnished the Contractor for the manufacturer at the first delivery of the pipe to the job.

02310-4

C. Polyethylene Pipe:

1. Polyethylene pipe for force mains shall conform to the requirements of ASTM Specification D-1248 (SDR 11), and have recommended designation valves of 3-3-5-4-3-3-C as referenced in ASTM D3350. Fittings shall be SDR 9.3.
2. Polyethylene pipe shall be supplied in standard lengths of at least 12' -6". Longer lengths are permitted.
3. Polyethylene pipe shall be marked with the manufacturer's name, production lot number, ASTM designation, and nominal diameter.

D. Polyvinyl Chloride (PVC) Force Main

1. PVC pipe shall comply with ASTM D1784 and shall be Class 200 (SDR 21) as shown on the Drawings. All PVC pipe shall conform to the latest revisions of the following specifications:
  - a. ASTM D2241 (PVC plastic pipe SDR-PR and Class T).
  - b. Commercial Standard CS 256 (pressure rated type).
  - c. National Sanitation Foundation Testing Laboratories (NSF).
2. The name of the manufacturer of the plastic pipe to be used must be found on the current listing of Plastic Materials for Potable Water Application, published by the NSF (National Sanitation Foundation), Ann Arbor, Michigan, and must meet the requirements of the Standard Specification for Polyvinyl Chloride (PVC) Plastic Pipe, D1784, published by ASTM (American Society for Testing and Materials). Rubber gasketing shall conform to ASTM 1869.
3. Pipe lengths shall not exceed 40 feet. Wall thickness shall be in accordance with CS-256 and ASTM D2241. Pipe ends shall be beveled to accept the gasketed coupling.
4. Samples of pipe, physical and chemical data sheets shall be submitted to the Engineer for approval and his approval shall be obtained before pipe is purchased.
5. The pipe shall be homogeneous throughout and free from cracks, holes, foreign inclusions or other defects. The pipe shall be as uniform as commercially practical in color.
6. Pipe shall have a ring painted around spigot ends in such a manner as to allow field checking of setting depth of pipe in the socket.
7. Pipe must be delivered to the job site by means which will adequately support it and not subject it to undue stresses. In particular, the load shall be so supported that the bottom rows of pipe are not damaged by crushing. Pipe shall be unloaded carefully and strung or stored as close to the final point of placement as is practical.
8. The couplings and fittings shall be furnished by the pipe manufacturer and shall accommodate the pipe for which they are to be used. They shall have a minimum pressure rating of 200 psi (SDR 21). Insertion depth of the pipe in the coupling shall be controlled by an internal PVC mechanical stop in the coupling which will allow for a

19012/6-2019

**PIPE AND FITTINGS FOR SANITARY SEWERS**

02310-5

thermal expansion and contraction. Coupling method shall allow for half of the expansion or contraction of each pipe section to be taken up at each end of the pipe. Couplings shall permit 5 degree deflection (2-1/2 degree each side) of the pipe without any evidence of infiltration, exfiltration, cracking or breaking. Couplings shall have rubber seals factory installed.

9. Pipe markings shall include the following, marked continuously down the length:
  - a. Manufacturer's name
  - b. Nominal size
  - c. Class pressure rating
  - d. PVC 1120
  - e. NSF Logo
  - f. Identification Code
10. Lubricant shall be water soluble, non-toxic, be nonobjectionable in taste and odor imparted to the fluid, non-supporting of bacteria growth, and have no deteriorating effect on the PVC or rubber gaskets.
11. All underground plastic piping shall have a colored metallic tape laid 2 feet above the pipe. The tape shall have the words "caution" printed on it and shall identify the pipe use. See Section 3.13.

## **2.02 PIPE JOINTING FOR DUCTILE IRON PIPE - MECHANICAL JOINT**

- A. Mechanical joints are to be furnished according to AWWA Specifications C111. All pipe joints must be furnished complete with all accessories. Mechanical joint bolts and nuts shall be of alloy cast iron (such as Acipcoloy) or alloy steel (Corten type such as US alloy) or approved equal. Rubber gaskets shall be made of plain first grade rubber, free of imperfections and porosity. Hardness shall be 70 to 75 durometer.
- B. Mechanical joints shall be used where specifically called for on the Drawings.
- C. Push-in socket joints shall be equal to manufacturer's specifications for "Tyton," "Bell-Tite," or "Fastite." The joints shall consist of a rubber ring gasket compressed in groove in bell of pipe with beveled spigot end of pipe for initial centering into rubber gasket in bell.
- D. All items used for jointing pipe shall be furnished with the pipe and tested before shipment. The joints shall be made with tools and lubricant in strict conformity with the manufacturer's instructions. If requested, three (3) copies of such instructions shall be delivered to the Engineer at start of construction.

## **2.03 PIPE JOINTING FOR PVC PIPE**

- A. Polyvinyl Chloride (PVC) Pipe Joints: Jointing of PVC pipe shall be by a natural rubber ring inserted in the belled end of the pipe or double hub joints. Solvent weld joints are not acceptable.
- B. Joints for PVC pipe shall be of the elastomeric gasket type and installed per the manufacturer's recommendations. Pipe that has been field cut must be beveled for insertion into gasketed joints. Bevel can be made with hand or power tool. In either case, the finished bevel should be the same as the factory bevel. All pipe shall be provided with home marks to insure proper gasket seating. Gasket material shall comply with the physical requirements specified in A.S.T.M. D-1869, C-361, C-433, current approval.
- C. Fittings for service connections shall be of the factory made in-line type conforming with the requirements of A.S.T.M. Specification D-3034, current approval. Saddle type fittings shall not be used.

19012/6-2019

**PIPE AND FITTINGS FOR SANITARY SEWERS**

02310-6

## **2.04 HIGH DENSITY POLYETHYLENE (HDPE) PIPE AND FITTINGS (GRAVITY SEWER)**

A. Polyethylene Pipe Joints: Jointing of polyethylene pipe shall be by the butt fusion method and shall be performed in strict conformance to the pipe manufacturer's recommendations using approved equipment. Fittings shall be connected with stainless steel couplings if fusion is not possible.

B. Where used in highway crossing, the Contractor shall take precautions to insure no damage to the pipe when placing it in the casing.

## **PART 3 - EXECUTION**

### **3.01 SHORING, SHEETING, AND BRACING OF EXCAVATION**

A. Where unstable material is encountered or where the depth of excavation in earth exceeds five (5) feet, the sides of the trench or excavation shall be supported by substantial sheeting, bracing, and shoring, or the sides sloped to the angle of repose. Sloping the sides of the ditch to the angle will not be permitted in streets, roads, narrow rights-of-way or other constricted areas unless otherwise specified. The design and installation of all sheeting, sheet piling, bracing and shoring shall be based on computations of pressure exerted by the materials to be retained under obtaining conditions. Adequate and proper shoring of all excavations shall be the entire responsibility of the Contractor; however, the Engineer may require the submission of shoring plans (accompanied by supporting computations) for approval prior to the Contractor undertaking any portion of the work. The standards of the Federal Occupational Safety and Health Act and the Ohio Department of Labor shall be followed.

B. Foundations, adjacent to where the excavation is to be made below the depth of the existing foundation, shall be supported by shoring, bracing or underpinning as long as the excavation shall remain open, or thereafter if required to insure the stability of the structure supported by the foundation, and the Contractor shall be held strictly responsible for any damage to said foundations.

C. Solid sheeting will be required for wet or unstable material. It shall consist of continuous vertical sheet piling of timber or steel with suitable wales and braces.

D. Care shall be taken to avoid excessive backfill loads on the completed pipelines and the trench width requirements at the level of the crown of the pipe and at the level of a road or street be strictly observed.

E. Trench sheeting shall not be removed until sufficient backfill has been placed to protect the pipe.

F. All sheeting, planking, timbering, bracing and bridging shall be placed, renewed and maintained as long as is necessary.

### **3.02 PIPE BEDDING - GRAVITY SEWERS**

A. All gravity sewer pipe shall be laid on a bed of granular material except when a concrete encasement situation occurs. All pipe bedding material shall be No. 9 crushed stone aggregate and shall be placed to a depth of 4" in an earth trench and 6" in a rock trench. The Contractor will not be permitted to use dense graded aggregate material for pipe bedding.

B. Pipe bedding shall be graded to provide for a uniform and continuous support beneath the pipe at all points.

C. After each pipe has been brought to grade, aligned, and placed in final position No. 9 crushed stone aggregate material shall be deposited and densified under the pipe haunches and on each side of the pipe up

19012/6-2019

**PIPE AND FITTINGS FOR SANITARY SEWERS**

02310-7

to the spring line of the pipe to prevent lateral displacement and hold the pipe in proper position during subsequent pipe jointing, bedding, and backfilling operations.

D. In wet, yielding and mucky locations where pipe is in danger of sinking below grade or floating out of grade or line, or where backfill materials are of such a fluid nature that such movements of pipe might take place during the placing of the backfill, the pipe must be weighted or secured permanently in place by such means as will prove effective.

E. Where an unstable (i.e., water, mud, etc.) trench bottom is encountered, stabilization of the trench bottom is required. This is to be accomplished by undercutting the trench depth and replacing to grade with a foundation of crushed stone aggregate. The depth of the foundation is dependent upon the severity of the trench bottom. The size of stone aggregate used in the foundation will be determined by the condition of the unstable material. Once the trench bottom has been stabilized, the required No. 9 crushed stone aggregate bedding material can be placed. No compensation for Crushed Stone for Pipe Foundation will be made if the instability of the trench bottom is caused by the Contractor's neglect.

F. It should be noted that no pipe shall be laid on solid or blasted rock.

### **3.03 PIPE LAYING**

A. The pipe shall be protected during handling against impact shocks and free fall. Care shall be taken to avoid dragging the spigot ring on the ground or allowing it to be damaged by contact with gravel, crushed stone, or other hard objects.

B. After being delivered alongside the trench, the pipe shall be carefully examined for soundness or damage. No piece of pipe or fitting which is known to be defective shall be laid or placed in the lines. If any defective pipe or fitting shall be discovered after the pipe is laid, it shall be removed and replaced with a satisfactory pipe or fitting without additional charge. Before each piece of pipe is lowered into the trench, it shall be thoroughly cleaned out. Each piece of pipe shall be lowered separately unless special permission is given otherwise by the Engineer. In case a length of pipe is cut to fit in a line, it shall be so cut as to leave a smooth end at right angles to the longitudinal axis of the pipe.

C. The bell and spigot of the joint shall be cleaned of dirt and foreign matter immediately prior to jointing. The contact surfaces shall be coated with the lubricant, primer or adhesive recommended by the pipe pushed together until the joint snaps distinctly in place. The pushing together of the pipe may be done by hand or by the use of a bar.

D. All pipe shall be laid straight between changes in alignment and at uniform grade between changes in grade. When jointed in the trench the pipe shall form a true and smooth line.

E. Trenches shall be kept dry during pipe laying. Before pipe laying is started, all water that may have collected in the trench shall be removed.

F. All pipe shall be laid starting at the lowest point and installed so that the spigot ends point in the direction of the flow.

### **3.04 PIPE BACKFILLING**

A. Backfilling is defined as that material which is placed over the gravity sewer from the spring line to a predetermined point above the top of the pipe according to various backfilling situation as defined in Section C, this article. The material shall be No. 9 crushed stone aggregate and may be machine placed without compaction. Uneven places in the backfill shall be leveled by hand.

02310-8

B. There are two cases where the method of backfilling varies. The various cases and their trench situations are as follows:

1. Case I - Areas not subject to vehicular traffic.
2. Case II - Areas under bituminous pavement.

C. In all cases, walking or working on the completed pipelines except as may be necessary in backfilling will not be permitted until the trench has been backfilled to a point six (6) inches above the top of the pipe. The method of final backfilling for each of the above cases is as follows:

1. Case I - The trench shall be backfilled from a point 6" above the top of the pipe to a point 8" below the surface of the ground with earth material free from large rock (over one-half cubic foot in volume), acceptable to the Engineer. The remainder of the trench to existing grade shall be backfilled with earth material reasonably free of any rocks.
2. Case II - The trench shall be backfilled to the existing grade with No. 9 crushed stone until the bituminous pavement replacement can be constructed. Extreme care shall be exercised to prevent damage to the pipe during the backfilling operation. Suitable equipment shall "walk" the trench for compaction. A slight mound may be left if, in the opinion of the Engineer or Owner, the public would not be inconvenienced.

Sufficient stockpiles of No. 9 crushed stone shall be placed throughout the project area to insure immediate replacement by the Contractor of any settled areas. No extra payment will be made for the filling in of settled areas by the Contractor.

D. Excavated materials from trenches and tunnels, in excess of quantity required for trench backfill, shall be disposed of by the Contractor. The Contractor may contact the Owner regarding the location of a suitable disposal site; however, if the Owner cannot recommend a site, it shall be the responsibility of the Contractor to obtain locations or permits for the disposal of the waste material.

### **3.05 CONNECTION TO EXISTING MANHOLES**

Where an existing manhole does not have existing stubs it will be necessary for the contractor to construct a new invert for the existing manhole.

### **3.06 UTILITY CROSSING CONCRETE ENCASEMENT**

A. At locations shown on the Contract Drawings, required by the Specifications, or as directed by the Engineer, concrete encasement shall be used when the clearance between the proposed sanitary sewer pipe and any existing utility pipe is eighteen (18) inches or less. Utility pipe includes underground water, gas, telephone and electrical conduit, storm sewers, and any other pipe as determined by the Engineer.

B. There are two cases of utility crossing encasement. Case I is applicable when the proposed sanitary sewer line is below the existing utility line. Case II is applicable when the proposed sanitary sewer line is laid above the utility line. In either case, the concrete shall extend to at least the spring line of each pipe involved.

C. Concrete shall be Class B (3000 psi) and shall be mixed sufficiently wet to permit it to flow between the pipes to form a continuous bridge. In tamping the concrete, care shall be taken not to disturb the grade or line of either pipe or damage the joints.

D. Concrete is not a separate pay item and will be considered incidental to gravity sewer installation.

### **3.07 BITUMINOUS PAVEMENT REPLACEMENT**

19012/6-2019

**PIPE AND FITTINGS FOR SANITARY SEWERS**

02310-9

A. Sections of pavement shall be replaced as required to install the pipelines under the work of this Section. Disturbed pavement shall be reconstructed to original lines and grades with bituminous binder as detailed on the Drawings and in such manner as to leave all such surfaces in fully as good or better condition than that which existed prior to these operations.

B. Prior to trenching, the pavement shall be scored or cut to straight edges along each side of the proposed trench to avoid unnecessary damage to the remainder of the paving. Edges of the existing pavement shall be recut and trimmed as necessary to square, straight edges after the pipe has been installed and prior to placement of the binder course.

C. Backfilling of trenches shall be in accordance with the applicable portions of Section 02226.

D. Bituminous concrete binder shall be one course construction in accordance with applicable provisions of the Kentucky Department of Highways Standard Specifications, Section 402. Placement and compaction of binder course shall be in accordance with Section 402 of the Kentucky Department of Highways Standard Specifications. Minimum thickness after compaction shall be as shown on the Drawings.

E. Bituminous pavement replacement is not a separate pay item and will be considered incidental to gravity sewer and force main installation. Where gravity sewer is installed within a paved street, full width pavement replacement will be required.

### **3.08 CRUSHED STONE BACKFILL**

A. The Class I granular material used in Case II and Case III backfill situations shall be No. 9 Crushed Stone aggregate (No. 9 Stone).

B. The twelve inches (12") of crushed stone backfill that is required in "City and County Maintained Streets, Roads and Driveway Pavement Replacement" or "State Maintained Streets and Roads Pavement Replacement" will not be paid for under the provisions of this article: crushed stone backfill is not a separate pay item and will be considered incidental to gravity sewer and force installation.

### **3.09 CRUSHED STONE SURFACE REPLACEMENT**

The Class II granular material used in Case II backfill situations shall be dense graded aggregate (D.G.A.). Granular material is not a separate pay item and will be considered incidental to gravity sewer and force main installation.

### **3.10 TESTING OF GRAVITY SEWER LINES**

A. After the gravity piping system has been brought to completion, and prior to final inspection, the contractor shall rod out the entire system by pushing through each individual line in the system, from manhole to manhole appropriate tools for the removal from the lines of any and all dirt, debris, and trash. If necessary during the process of rodding the system, water shall be turned into the system in such quantities to carry off the dirt, debris and trash.

B. During the final inspection, the Engineer will inspect each individual line, from manhole to manhole, by the use of television or other means at his disposal as approved by the Engineer to determine whether the completed lines are true to line and grade as laid out or as shown on the Drawings.

1. Deflection testing of all gravity sewer lines shall be required. The test shall be conducted after the backfill has been in place at least 24 hours.

19012/6-2019

**PIPE AND FITTINGS FOR SANITARY SEWERS**



02310-10

No pipe shall exceed a deflection of 5%.

The test shall be run with a rigid ball or an engineer-approved 9-arm mandrel having a diameter equal to 95% of the inside diameter of the pipe. The test must be Performed by manually pulling the device through the line.

2. All lines or sections of lines that are found to be laid improperly with respect to line or grade, that are found to contain broken or leaking sections of pipe, or are obstructed in such a manner that they cannot be satisfactorily corrected otherwise, shall be removed and replaced at the Contractor's expense.

C. The pipe line shall be made as nearly watertight as practicable, and leakage tests and measurements shall be made. All apparatus and equipment required for testing shall be furnished by the Contractor and the cost shall be included in the unit price bid for pipe and manholes.

1. The Engineer may require the Contractor to smoke test the first section (manhole to manhole) of each size of pipe and type of joint prior to backfilling, to establish and check laying and jointing procedures. The test shall consist of smoke blown into closed-off sections of sewer under pressure and observing any smoke coming from the pipe line indicating the presence of leaks. Other supplementary smoke tests prior to backfilling may be performed by the Contractor at his option; however, any such tests shall not supplant the final tests of the completed work unless such final tests are waived by the Engineer.
2. Where the groundwater level is more than 1 foot above the top of the pipe at its upper end, the Contractor shall conduct either infiltration tests or low pressure air test on the completed pipeline.
3. Where the groundwater level is less than 1 foot above the top of the pipe at its upper end, the Contractor shall conduct either exfiltration tests or low pressure air tests on the completed pipeline.

D. Low pressure air tests shall be made using equipment specifically designed and manufactured for the purpose of testing sewer lines using low pressure air. The equipment shall be provided with an air regulator valve or air safety valve so set that the internal pressure in the pipeline cannot exceed 8 psig.

1. The test shall be made on each manhole-to-manhole section of pipeline after placement of the backfill. The Engineer or his designated representative must be present to witness each satisfactory air test before it will be accepted as fulfilling the requirements of these specifications.
2. Pneumatic plugs shall have a sealing length equal to or greater than the diameter of the pipe to be tested. Pneumatic plugs shall resist internal test pressures without requiring external bracing or blocking.
3. Low pressure air passing through a single control panel, shall be introduced into the sealed line until the internal air pressure reaches 4 psig greater than the maximum pressure exerted by groundwater that may be above the invert of the pipe at the time of test. However, the internal air pressure in the sealed line shall not be allowed to exceed 8 psig. When the maximum pressure exerted by the groundwater is greater than 4 psig, the Contractor shall conduct only an infiltration test.

02310-11

- 4. At least two minutes shall be allowed for the air pressure to stabilize in the section under test. After the stabilization period the low-pressure air supply hose shall be quickly disconnected from the control panel. The time required in minutes for the pressure in the section under test to decrease from 3.5 to 2.5 psig (greater than the maximum pressure exerted by groundwater that may be above the invert of the pipe) shall not be less than that shown in the following table:

<u>Pipe in Diameter in Inches</u>	<u>Minutes</u>
4	2.0
6	3.0
8	4.0
10	5.0
12	5.5
15	7.5
18	8.5
21	10.0
24	11.5
30	13.5

- 5. When the sewer section to be tested contains more than one size of pipe, the minimum allowable time shall be based on the largest diameter pipe in the section, and shall be the time shown in the table reduced by 0.5 minutes.

E. Infiltration Tests:

- 1. Infiltration tests shall be made after underdrains, if present, have been plugged and other groundwater drainage has been stopped such that the groundwater is permitted to return to its normal level insofar as practicable.
- 2. Upon completion of a section of the pipeline, the line shall be dewatered and a satisfactory test conducted to measure infiltration for at least 24 hours. The amount of infiltration, including manholes, tees and connections, shall not exceed 200 gallons per nominal inch diameter per mile of sewer per 24 hours.

F. Exfiltration tests which subject the pipeline to an internal pressure, shall be made by plugging the pipe at the lower end and then filling the line and manholes with clean water to a height of 2 feet above the top of the sewer at its upper end. Where conditions between manholes may result in test pressures which would cause leakage at the plugs or stoppers in branches, provisions shall be made by suitable ties, braces and wedges to secure the plugs against leakage resulting from the test pressure.

- 1. The rate of leakage from the sewers shall be determined by measuring the amount of water required to maintain the level 2 feet above the top of the pipe.
- 2. Leakage from the sewers under test shall not exceed the requirements for leakage into sewers as hereinbefore specified.

G. The Contractor shall furnish suitable test plugs, water pumps, and appurtenances, and all labor required to properly conduct the tests. Suitable bulkheads shall be installed, as required, to permit the test of the sewer. The Contractor shall construct weirs or other means of measurements as may be necessary.

02310-12

H. Should the sections under test fail to meet the requirements, the Contractor shall do all work of locating and repairing the leaks and retesting as the Engineer may require without additional compensation.

I. If in the judgement of the Engineer, it is impracticable to follow the foregoing procedures for any reason, modifications in the procedures shall be made as required and as acceptable to the Engineer, but in any event, the Contractor shall be responsible for the ultimate tightness of the line within the above test requirements.

### 3.11 TESTING OF FORCE MAINS

The completed work shall comply with the provisions listed below, or similar requirements which will insure equal or better results:

A. The pipe shall be hydrostatically tested at 1.5 times the design working pressure at the point of testing. The duration of the test(s) shall be at least 2 hours during which time the pressure shall not fall more than 5 psi. The pipe shall be tested for allowable leakage according to AWWA C-600 (latest revision) concurrently with the pressure test.

B. Where practicable, pipelines shall be tested between line valves or plugs in lengths of not more than 3000 feet. Testing shall proceed from the pump station toward the termination of the line. The line shall be tested upon the completion of the first 3000 feet. After the completion of two consecutive tests without failure, the Contractor, at his option and with the Engineer's approval, may discontinue testing until the system is complete.

C. Duration of test shall be not less than 2 hours.

D. Lines which fail to meet tests shall be repaired and retested as necessary until test requirements are complied with.

E. All pipe, fittings and other materials found to be defective under test shall be removed and replaced at the Contractor's expense.

F. Test pressures shall not be less than 1.25 times the working pressure at the highest point along the test section, not exceed pipe or thrust restraint design pressure, not vary more than +5 psi.

G. Before applying the specified test pressure, air shall be expelled completely from the pipe. If permanent air vents are not located at high points within the test section, the Contractor shall install corporation cocks at such points so that the air can be expelled as the line is filled with water.

### 3.12 LEAKAGE TEST

A. The leakage shall be defined as the quantity of water that must be supplied to the tested section to maintain pressure within 5 psi of the specified test pressure after the air in the pipeline has been expelled and the pipe has been filled with water.

B. The allowable leakage shall not be greater than that determined by the following formula:

$$L = \frac{ND(P)}{7400}^{1/2}$$

Where L is the allowable leakage in gallons per hour; N is the number of joints in the length of pipeline tested; D is the nominal diameter of the pipe, in inches; and P is the average test pressure during the leakage test, in pounds per square inch gage.

C. All visible leaks are to be repaired regardless of the amount of leakage.

19012/6-2019

**PIPE AND FITTINGS FOR SANITARY SEWERS**

02310-13

### **3.13 PLACEMENT OF IDENTIFICATION TAPE AND ABOVE GROUND UTILITY MARKER**

A. The placement of detectable underground marking tape shall be installed over all utility lines. Care shall be taken to insure that the buried marking tape is not broken when installed and shall be Lineguard brand encased aluminum foil, Type III. The identification tape is manufactured by Lineguard, Inc., P.O. Box 426, Wheaton, IL 60187.

B. The identification tape shall bear the printed identification of the utility line below it, such as "CAUTION - BURIED FORCE MAIN BELOW." Tape shall be reverse printed, surface printing will not be acceptable. The tape shall be visible in all types and colors of soil and provide maximum color contrast to the soil. The tape shall meet the APWA color code, and shall be two (2) inches in width. Colors are: yellow - gas, green - sewer, red - electric, blue - water, orange -- telephone, brown - force main.

C. The tape shall be the last equipment installed in the ditch so as to be first out. The tape shall be buried 4 - 6 inches below top of grade. After trench backfilling, the tape shall be placed in the backfill and allowed to settle into place with the backfill. The tape may be plowed in after final settlement, installed with a tool during the trench backfilling process, unrolled before final restoration or installed in any other way acceptable to the owner or his agent or engineer.

D. An above ground utility marker shall be installed every 500 feet along the route of the underground sewage force main. The marker shall be approximately 3" in width and 4.5 feet in length, as manufactured by Carsonite, Inc. or equal.

### **3.14 PLACEMENT OF TRACING WIRE**

Detectable underground copper tracing wire shall be installed with all utility lines. Insulated copper trace wire shall be attached to the top of the pipe with adhesive tape or other suitable devices. At each hydrant, valve, customer meter services and end of new pipe installation, the trace wire shall be daylighted and the ends connected together with split bolt connectors covered with waterproof connectors. For long runs of pipe, the maximum unbroken length of the trace wire shall be 760 meters (2500 feet). Underground splicing shall be made using brass split bolt electrical connectors and covered with waterproof tape or wrap. The trace wire shall be solid #14 AWG THWN copper.

- END OF SECTION -

02502-1

## SECTION 02502

### RESTORATION OF SURFACES

#### PART 1 GENERAL

##### 1.01 SUMMARY

- A. This Section includes restoration and maintenance of all types of surfaces, sidewalks, curbs, gutters, culverts and other features disturbed, damaged or destroyed during the performance of the work under or as a result of the operations of the Contract.
- B. The quality of materials and the performance of work used in the restoration shall produce a surface or feature equal to the condition of each before the work began.

##### 1.02 REFERENCES

- A. Materials and installation shall be in accordance with the latest revisions of the following codes, standards and specifications, except where more stringent requirements have been specified herein:
  - 1. American Society for Testing and Materials (ASTM)
    - a. D698 - Test Method for Laboratory Compaction Characteristics of Soil Using Standard Effort (12,400 ft-lbf/ft<sup>3</sup>) (600 kN-m/m<sup>3</sup>)

##### 1.03 SUBMITTALS

- A. In addition to those submittals identified in the General Provisions, the following items shall be submitted:
  - 1. A schedule of restoration operations. After an accepted schedule has been agreed upon it shall be adhered to unless otherwise revised with the approval of the Engineer.

#### PART 2 PRODUCTS

NOT USED

#### PART 3 EXECUTION

##### 3.01 GENERAL

- A. In general, permanent restoration of paved surfaces will not be permitted until one months' time has elapsed after excavations have been completely backfilled as specified. A greater length of time, but not more than nine months may be allowed to elapse before permanent restoration of street surfaces is undertaken, if additional time is required for shrinkage and settlement of the backfill.
- B. The replacement of surfaces at any time, as scheduled or as directed, shall not relieve the Contractor of responsibility to repair damages by settlement or other failures.

02502-2

### **3.02 TEMPORARY PAVEMENT**

- A. Immediately upon completion of refilling of the trench or excavation, the Contractor shall place a temporary pavement over all disturbed areas of streets, driveways, sidewalks, and other traveled places where the original surface has been disturbed as a result of his operations.
- B. Unless otherwise specified or directed the temporary pavement shall consist of compacted run-of-crusher limestone to such a depth as required to withstand the traffic to which it will be subjected.
- C. Where concrete pavements are removed, the temporary pavement shall be surfaced with "cold patch". The surface of the temporary pavement shall conform to the slope and grade of the area being restored.
- D. For dust prevention, the Contractor shall treat all surfaces, not covered with cold patch, as frequently as may be required.
- E. The temporary pavement shall be maintained by the Contractor in a safe and satisfactory condition until such time as the permanent paving is completed. The Contractor shall immediately remove and restore all pavement as shall become unsatisfactory.

### **3.03 PERMANENT PAVEMENT REPLACEMENT**

- A. The permanent and final repaving of all streets, driveways and similar surfaces where pavement has been removed, disturbed, settled or damaged by or as a result of performance of the Contract shall be repaired and replaced by the Contractor, by a new and similar pavement.
  - 1. The top surface shall conform with the grade of existing adjacent pavement and the entire replacement shall meet the current specifications of the local community for the particular types of pavement.
  - 2. Where the local community has no specification for the type of pavement, the work shall be done in conformity with the State Department of Transportation Standard which conforms the closest to the type of surfacing being replaced, as determined by the Engineer.

### **3.04 PREPARATION FOR PERMANENT PAVEMENT**

- A. When scheduled and within the time specified, the temporary pavement shall be removed and a base prepared, at the depth required by the local community or Highway Permit, to receive the permanent pavement.
  - 1. The base shall be brought to the required grade and cross-section and thoroughly compacted before placing the permanent pavement.
  - 2. Any base material which has become unstable for any reason shall be removed and replaced with compacted base materials.
- B. Prior to placing the permanent pavement all service boxes, manhole frames and covers and similar structures within the area shall be adjusted to the established grade and cross-section.

02502-3

- C. The edges of existing asphalt pavement shall be cut a minimum of 1 foot beyond the excavation or disturbed base whichever is greater.
  - 1. All cuts shall be parallel or perpendicular to the centerline of the street.

### **3.05 ASPHALT PAVEMENT**

- A. The permanent asphalt pavement replacement for streets, driveways and parking area surfaces shall be replaced with bituminous materials of the same depth and kind as the existing unless otherwise specified.
- B. Prior to placing of any bituminous pavement a sealer shall be applied to the edges of the existing pavement and other features.
- C. The furnishing, handling and compaction of all bituminous materials shall be in accordance with the State Department of Transportation Standards.

### **3.06 CONCRETE PAVEMENT AND PAVEMENT BASE**

- A. Concrete pavements and concrete bases for asphalt, brick or other pavement surfaces shall be replaced with Class "B" Concrete, air-entrained.
- B. Paving slabs or concrete bases shall be constructed to extend 1 foot beyond each side of the trench and be supported on undisturbed soil. Where such extension of the pavement will leave less than 2 feet of original pavement slab or base, the repair of the pavement slab or base shall be extended to replace the slab to the original edge of the pavement or base unless otherwise indicated on the Contract Drawings.
- C. Where the edge of the pavement slab or concrete base slab falls within the excavation, the excavation shall be backfilled with Special Backfill compacted to 95% maximum dry density as determined by ASTM D 698 up to the base of the concrete.
- D. The new concrete shall be of the same thickness as the slab being replaced and shall contain reinforcement equal to the old pavement.
  - 1. New concrete shall be placed and cured in accordance with the applicable provisions of the State Department of Transportation Standards.

### **3.07 STONE OR GRAVEL PAVEMENT**

- A. All pavement and other areas surfaced with stone or gravel shall be replaced with material to match the existing surface unless otherwise specified.
  - 1. The depth of the stone or gravel shall be at least equal to the existing.
  - 2. After compaction the surface shall conform to the slope and grade of the area being replaced.

### **3.08 CONCRETE WALKS, CURBS AND GUTTER REPLACEMENT**

- A. Concrete walks, curbs and gutters removed or damaged in connection with or as a result of the construction operations shall be replaced with new construction.
  - 1. The minimum replacement will be a flag or block of sidewalk and 5 feet of curb or gutter.

02502-4

- B. Walks shall be constructed of Class "B" concrete, air-entrained with KY-DOT #2 stone aggregate on a 4-inch base of compacted gravel or stone.
  - 1. The walk shall be not less than 4 inches in thickness or the thickness of the replaced walk where greater than 4 inches, shall have construction joints spaced not more than 25 feet apart, shall have expansion joints spaced not more than 50 feet apart and shall be sloped at right angles to the longitudinal centerline approximately inch per foot of width.
- C. 1/2-inch expansion joint material shall be placed around all objects within the sidewalk area as well as objects to which the new concrete will abut, such as valve boxes, manhole frames, curbs, buildings and others.
- D. Walks shall be hand-floated and broom-finished, edged and grooved at construction joints and at intermediate intervals matching those intervals of the walk being replaced.
  - 1. The intermediate grooves shall be scored a minimum of 1/4 of the depth of the walk.
  - 2. The lengths of blocks formed by the grooving tool, and distances between construction and expansion joints shall be uniform throughout the length of the walk in any one location.
- E. The minimum length of curb or gutter to be left in place or replaced shall be 5 feet. Where a full section is not being replaced, the existing curb or gutter shall be saw cut to provide a true edge.
  - 1. The restored curb or gutter shall be the same shape, thickness and finish as being replaced and shall be built of the same concrete and have construction and expansion joints as stated above for sidewalks.
- F. All concrete shall be placed and cured as specified in the Section for concrete.

### **3.09 LAWNS AND IMPROVED AREAS**

- A. The area to receive topsoil shall be graded to a depth of not less than 4 inches or as specified, below the proposed finished surface.
  - 1. If the depth of existing topsoil prior to construction was greater than 4 inches, topsoil shall be replaced to that depth.
- B. The furnishing and placing of topsoil, seed and mulch shall be in accordance with the Section entitled "Topsoil and Seeding".
- C. When required to obtain germination, the seeded areas shall be watered in such a manner as to prevent washing out of the seed.
- D. Any washout or damage which occurs shall be regraded and reseeded until a good sod is established.
- E. The Contractor shall maintain the newly seeded areas, including regrading, reseeding, watering and mowing, in good condition.



02502-5

### **3.10 CULTIVATED AREA REPLACEMENT**

- A. Areas of cultivated lands shall be graded to a depth to receive topsoil of not less than the depth of the topsoil before being disturbed. All debris and inorganic material shall be removed prior to the placing of the topsoil.
- B. The furnishing and placing of topsoil shall be in accordance with the Section entitled "Topsoil and Seeding".
- C. After the topsoil has been placed and graded, the entire area disturbed during construction shall be cultivated to a minimum depth of 12-inches with normal farm equipment.
  - 1. Any debris or inorganic materials appearing shall be removed.
  - 2. The removal of stones shall be governed by the adjacent undisturbed cultivated area.
- D. Grass areas shall be reseeded using a mixture equal to that of the area before being disturbed, unless otherwise specified.

### **3.11 OTHER TYPES OF RESTORATION**

- A. Trees, shrubs and landscape items damaged or destroyed as a result of the construction operations shall be replaced in like species and size.
  - 1. All planting and care thereof shall meet the standards of the American Association of Nurserymen.
- B. Water courses shall be reshaped to the original grade and cross-section and all debris removed. Where required to prevent erosion, the bottom and sides of the water course shall be protected.
- C. Culverts destroyed or removed as a result of the construction operations shall be replaced in like size and material and shall be replaced at the original location and grade. When there is minor damage to a culvert and with the consent of the Engineer, a repair may be undertaken, if satisfactory results can be obtained.
- D. Should brick pavements be encountered in the work, the restoration shall be as set forth in the Special Provisions or as directed.

### **3.12 MAINTENANCE**

- A. The finished products of restoration shall be maintained in an acceptable condition for and during a period of one year following the date of Substantial Completion or other such date as set forth elsewhere in the Contract Documents.

-END OF SECTION-

02502-1

## **SECTION 02531**

### **SEWAGE FORCE MAINS**

#### **PART 1 - GENERAL**

##### **1.01 SCOPE OF WORK**

A. Provide all labor, materials, equipment and services required for furnishing and installing all piping and appurtenances specified herein.

##### **1.02 RELATED WORK SPECIFIED ELSEWHERE**

A. Earthwork: Section 02300

B. Buried Valves: 02515

##### **1.03 SUBMITTALS**

A. A notarized certification shall be furnished for all pipe and fittings that verifies compliance with all applicable specifications.

B. The requirement for this certification does not eliminate the need for shop drawings submittals in compliance with Section 01340.

##### **1.04 UTILITY LINE ACTIVITIES COVERED UNDER NATIONWIDE PERMIT # 12**

All activities involving utility line construction covered under NATIONWIDE PERMIT # 12 shall meet the following conditions:

A. The general Water Quality Certification is limited to the crossing of intermittent and perennial streams by utility lines.

B. The construction of permanent or temporary access roads will impact less than 300 linear feet of intermittent and perennial streams and less than one acre of jurisdictional wetlands.

C. Utility lines shall be located at least 50 feet away from a stream which appears as a blue line on a USGA 7 ½ minute topographic map except where the utility line alignment crosses the stream. Utility lines that cross streams shall be constructed by methods that maintain normal stream flow and allow for a dry excavation. Water pumped from the excavation shall be contained and allowed to settle prior to re-entering the stream. Excavation equipment and vehicles shall operate outside of the flowing portion of the stream. Spoil material from the utility line excavation shall not be allowed to enter the flowing portion of the stream.

D. The activities shall not result in any permanent changes in preconstruction elevation contours in waters or wetlands or stream dimension, pattern or profile.

E. Utility line construction projects through jurisdictional wetlands shall not result in conversion of the area to non-wetland status.

02502-2

F. Measures shall be taken to prevent or control spills of fuels, lubricants, or other toxic materials used in construction from entering the watercourse.

G. Removal of riparian vegetation in the utility line right-of-way shall be limited to that necessary for equipment access. Effective erosion and sedimentation control measures must be employed at all times during the project to prevent degradation of waters of the Commonwealth. Site regrading and reseeding will be accomplished within 14 days after disturbance.

H. To the maximum extent practicable, all in stream work under this certification shall be performed during low flow.

I. Heavy equipment, e.g. bulldozers, backhoes, draglines, etc., if required for this project, should not be used or operated within the stream channel. In those instances where such in stream work is unavoidable, then it shall be performed in such a manner and duration as to minimize turbidity and disturbance to substrates and bank or riparian vegetation.

J. Any fill shall be of such composition that it will not adversely affect the biological, chemical, or physical properties of the receiving waters and/or cause violations of water quality standards. If riprap is utilized, it is to be of such weight and size that bank stress or slump conditions will not be created because of its placement.

K. Removal of existing riparian vegetation should be restricted to the minimum necessary for project construction.

L. Should evidence of stream pollution or jurisdictional wetland impairment and/or violations of water quality standards occur as a result of this activity (either from a spill or other forms of water pollution), the Kentucky Division of Water shall be notified immediately by calling 800/928-2380.

## **1.05 CONSTRUCTION IN A FLOODPLAIN**

No material shall be placed in the stream or in the flood plain to form construction pads, coffer dams, access roads, etc. unless prior approval has been obtained from the Environmental and Public Protection Cabinet.

The trench shall be backfilled as closely as possible to the original contour. All excess material from construction of the trench shall be disposed of outside the flood plain unless the applicant has received prior approval from the Cabinet to fill within the flood plain.

## **PART 2 PRODUCTS**

### **2.01 PVC PIPE AND FITTINGS**

A. PVC Pressure Pipe, 3" and Smaller: Polyvinyl chloride plastic pipe shall be ASTM D 1785 Schedule 80 with solvent weld joints. Fittings shall be ASTM D 2467 Schedule 80 socket type. All socket type connections shall be made with PVC solvent cement complying with ASTM D 2564. PVC solvent cement shall be furnished from the same supplier as the PVC pipe. Provide socket-threaded adapters for connection to threaded appurtenances where required.

B. PVC Pressure Piping, 4" and Larger: PVC mains shall be polyvinyl chloride plastic pipe, Class 200 (SDR-21) pressure rated pipe. All PVC pipe shall conform to the latest revisions of the following:

ASTM D 2241  
Standard Dimension Ratio SDR-21 (200 psi)

02502-3

- C. Fittings for the pipe shall be constructed of the same plastic material as is used for the pipe, minimum 200 psi pressure rating, gasketed and shall be of the molded type or machined from extruded stock.
- D. Joints for polyvinyl chloride (PVC) mains shall be integral bell and spigot type joints with rubber O-ring gasket. The cleaning and assembling of the pipe joints shall be in accordance with manufacturer's recommendations.

## 2.02 COUPLING AND ADAPTORS

A. Flexible couplings shall be of the sleeve type with a middle ring, two wedge shaped resilient gaskets at each end, two follower rings, and a set of steel trackhead bolts. The middle ring shall be flared at each end to receive the wedge portion of the gaskets. The follower rings shall confine the outer ends of the gaskets, and tightening of the bolts shall cause the follower rings to compress the gaskets against the pipe surface, forming a leak-proof seal. Flexible couplings shall be steel with minimum wall thickness of the middle ring or sleeve installed on pipe being 5/16 inch for pipe smaller than 10 inches, 3/8 inch for pipe 10 inches or larger. The minimum length of the middle ring shall be 5 inches for pipe sizes up to 10 inches and 7 inches for pipe 10 inches to 30 inches. The pipe stop shall be removed. Gaskets shall be suitable for 250 psi pressure rating or at rated working pressure of the connecting pipe. Couplings shall be harnessed and be designed for 250 psi.

B. Flanged adapters shall have one end suitable for bolting to a pipe flange and the other end of flexible coupling similar to that described hereinbefore. All pressure piping with couplings or adapters shall be harnessed with full threaded rods spanning across the couplings or adapters. The adapters shall be furnished with bolts of an approved corrosion resistant steel alloy, extending to the adjacent pipe flanges. Flanges on flanged adapter (unless otherwise indicated or required) shall be faced and drilled ANSI B16.1 Class 125.

C. Flexible couplings and flanged adapters shall be as manufactured by Dresser, Rockwell, or equal, per the following, unless otherwise specified and/or noted on the Drawings:

D. Steel couplings for joining same size, plain-end, steel, cast iron, and PVC plastic pipe

Dresser Rockwell  
Style 138 411

E. Transition couplings for joining pipe of different outside diameters

Dresser Rockwell  
Style 162 (4" 12") 413 steel (2" 24")  
Style 62 (2" 24") 415 steel (6" 48")  
433 cast (2" 16")  
435 cast (2" 12")

F. Flanged adapters for joining plain end pipe to flanged pipe, fittings, valves and equipment.

Dresser Rockwell  
Style 127 cast (3" 12") 912 cast (3" 12")  
Style 128 steel (3" 48" C.I. Pipe) 913 steel (3" and larger)  
Style 128 steel (2" 96" steel pipe)

## 2.03 DETECTABLE UNDERGROUND UTILITY WARNING TAPES

02502-4

- A. Detectable underground utility warning tapes which can be located from the surface by a pipe detector shall be installed directly above nonmetallic (PVC, polyethylene, concrete) pipe.
- B. The tape shall consist of a minimum thickness 0.35 mils solid aluminum foil encased in a protective inert plastic jacket that is impervious to all know alkalis, acids, chemical reagents and solvents found in the soil.
- C. The minimum overall thickness of the tape shall be 5.5 mils and the width shall not be less than 2" with a minimum unit weight of 2-1/2 pounds/1" x 1,000'. The tape shall be color coded and imprinted with the message as follows:
 

Type of Utility	Color Code	Legends
Sewer	Safety Green	Caution Buried Sewer Line Below
- D. Detectable underground tape shall be "Detect Tape" as manufactured by Allen Systems, or equal.
- E. Installation of detectable tapes shall be per manufacturer's recommendations and shall be as close to the grade as is practical for optimum protection and detectability. Allow a minimum of 18" between the tape and the line.
- F. Payment for detectable tapes shall be included in the linear foot price bid of the appropriate bid item(s) unless it is listed as a separate payment item in the bid schedule.

**2.04 CONCRETE PIPE ANCHORS, THRUST BLOCKS, CRADLE OR ENCASEMENT**

- A. Where indicated on the Drawings, required by the specifications or as directed by the Engineer, concrete pipe anchors, thrust blocks, cradles or encasements shall be installed. Concrete shall be 2000 psi, and reinforcing bars shall be as installed as indicated on the details.

**PART 3 EXECUTION**

**3.01 EXCAVATION FOR PIPELINE TRENCHES**

- A. Unless otherwise directed by the Engineer, trenches in which pipes are to be laid shall be excavated in open cut to the depths required by field conditions or as specified by the Engineer. In general this shall be interpreted to mean that machine excavation in earth shall not extend below an elevation permitting the pipe to be properly bedded. Installation shall be in accordance with ASTM-D-2321 except as modified herein.
- B. If the foundation is good firm earth and the machine excavation has been accomplished as set out hereinbefore, the remainder of the material shall be excavated by hand, then the earth pared or molded to give full support to the lower quadrant of the barrel of each pipe. Where bell and spigot is involved, bell holes shall be excavated during this latter operation to prevent the bells from being supported on undisturbed earth. If for any reason the machine excavation in earth is carried below an excavation that will permit the type of bedding specified above, then a layer of granular material shall be placed so that the lower quadrant of the pipe will be securely bedded in compact granular fill.
- C. Excavation may be undercut to a depth below the required invert elevation that will permit laying the pipe in a bed of granular material to provide continuous support for the bottom quadrant of the pipe. When this method is used, the bedding shall be as set out in Paragraph 3.02 hereinafter.
- D. Trenches shall be of sufficient width to provide free working space on each side of the pipe and to permit proper backfilling around the pipe, but unless specifically authorized by the Engineer, trenches shall in

02502-5

no case be excavated or permitted to become wider than 2'-0" plus the nominal diameter of the pipe at the level of or below the top of the pipe. If the trench does become wider than 2'-0" at the level of or below the top of the pipe, special precaution may be necessary, such as providing compacted, granular fill up to top of the pipe or providing pipe with additional crushing strength as determined by the Engineer after taking into account the actual trench loads that may result and the strength of the pipe being used. The Contractor shall bear the cost of such special precautions as are necessary.

E. All excavated materials shall be placed a minimum of two feet (2') back from the edge of the trench.

F. Before laying the pipe, the trench shall be opened far enough ahead to reveal obstructions that may necessitate changing the line or grade of the pipeline.

G. The trench shall be straight and uniform so as to permit laying pipe to lines and grades given by the Engineer. It shall be kept free of water during the laying of the pipe and until the pipeline has been backfilled. Removal of trench water shall be at the Contractor's expense. Dry conditions shall be maintained in the excavations until the backfill has been placed. During the excavation, the grade shall be maintained so that it will freely drain and prevent surface water from entering the excavation at all times. When directed by Owner, temporary drainage ditches shall be installed to intercept or direct surface water which may affect work. All water shall be pumped or drained from the excavation and disposed of in a suitable manner without damage to adjacent property or to other work.

H. Minimum cover of 30" shall be provided for all pipelines, except those located in the State Highway Right of Way. Those shall have a minimum cover of 42".

### **3.02 PIPE BEDDING**

A. All sewer pipe shall be supported on a bed of granular material unless the trench has been prepared in accordance with Paragraph 3.01B. In no case shall pipe be supported directly on rock. Bedding shall not be a separate pay item unless otherwise set out in the Detailed Specifications. Bedding shall be provided in earth bottom trenches, as well as rock bottom trenches. Bedding material shall be free from large rock, foreign material, frozen earth, and shall be acceptable to the Engineer. Bedding shall be a minimum of 6" below pipe barrel.

B. In all cases the foundation for pipes shall be prepared so that the entire load of the backfill on top of the pipe will be carried on the barrel of the pipe so that none of the load will be carried on the bells.

C. Where flexible pipe is used, the bedding shall be placed up to at least the spring line (horizontal center line) of the pipe. The bedding material and procedures shall conform to ASTM D 2321 and any Technical Specifications set out hereinafter. If conditions warrant, the Engineer may require the bedding to be placed above the springline of the pipe. Granular bedding shall be Size #9 m or ASTM C 33, Size #7 crushed stone, fine gravel, or sand, and is not a separate pay item.

D. Where undercutting and granular bedding is involved it shall be of such depth that the bottom of the bells of the pipe will be at least three inches above the bottom of the trench as excavated. Undercutting is not a separate pay item.

E. In wet, yielding mucky locations where pipe is in danger of sinking below grade or floating out of line or grade, or where backfill materials are of such a fluid nature that such movements of the pipe might take place during the placing of the backfill, the pipe must be weighted or secured permanently in place by such means as will prove effective. When ordered by the Engineer, yielding and mucky materials in subgrades shall be removed below ordinary trench depth in order to prepare a proper bed for the pipe. Crushed stone or other such granular material, if necessary, as determined by the Engineer to replace poor subgrade material, shall be classified as "Fill" (No separate pay item). Removal of poor material is not a separate pay item.

02502-6

F. Installation shall be in accordance with ASTM D 2321 except as modified hereinafter.

### **3.03 SPECIAL GRANULAR FILL**

A. As noted in Paragraph 3.02E, granular material for "Special Granular Fill " when directed by the Engineer shall be Department of Transportation crushed limestone, Size #57. Payment for "Special Granular Fill" must have approval from the Engineer prior to installation.

### **3.04 LAYING PIPE**

A. The laying of pipe in finished trenches shall be commenced at the lowest point so the spigot ends point in the direction of flow.

B. All pipes shall be laid with ends abutting and true to line and grade as given by the Engineer. Supporting of pipes shall be as set out hereinbefore under "Pipe Bedding" and in no case shall the supporting of pipes on blocks be permitted.

C. Before each piece of pipe is lowered into the trench, it shall be thoroughly inspected to insure it's being cleaned. Each piece of pipe shall be lowered separately unless special permission is given otherwise by the Engineer. No piece of pipe or fitting which is known to be defective shall be laid or placed in the lines. If any defective pipe or fitting shall be discovered after the pipe is laid, they shall be removed and replaced with a satisfactory pipe or fitting without additional charge. In case a length of pipe is cut to fit in a line it shall be so cut as to leave a smooth end at right angles to the longitudinal axis of the pipe.

D. Pipe shall not be laid on solid rock. A pad of granular material as specified in Paragraph 3.02 "Pipe Bedding", shall be used as a pipe bedding. Pipe bedding is not a separate pay item. Irregularities in subgrade in an earth trench shall be corrected by use of granular material.

E. When ordered by the Engineer, unsuitable materials in subgrades shall be removed below ordinary trench depth in order to prepare a proper bed for the pipe.

F. When laying of pipe is stopped for any reason, the exposed end of such pipe shall be closed with a plywood or fabricated plug fitted into the pipe bell, so as to exclude earth or other material, and precautions taken to prevent flotation of pipe by runoff into trench.

G. No backfilling (except for securing pipe in place) over pipe will be allowed until the Engineer has had an opportunity to make an inspection of the joints, alignment and grade, in the section laid.

### **3.05 BACKFILLING PIPELINE TRENCHES**

A. Backfilling of pipeline trenches shall be accomplished with the requirements set forth in "Earthwork" Section 02300 as shown on the Drawings and with details set forth hereinafter.

B. Method "A" - Backfilling in Open Terrain:

Backfilling of pipeline trenches in open terrain shall be accomplished in the following manner:

1. The lower portion of the trench, from the pipe bedding to a point 12" above the top of the pipe, shall be backfilled with material free from rock and/or material acceptable to the Engineer. This material shall be placed in a manner approved by the Engineer, and shall be carefully compacted to avoid displacement of the pipe.

02502-7

Compaction shall be accomplished by hand-tamping or by approved mechanical methods.

2. The upper portion of the trench above the compacted portion shall be backfilled with material which is free from large rock. Incorporation of rock having a volume exceeding one-half cubic foot is prohibited. Backfilling this portion of the trench may be accomplished by any means approved by the Engineer. The trench backfill shall be heaped over or leveled as directed by the Engineer.

C. Method "B" - Backfilling Under Sidewalks & Unpaved Driveways:

Backfilling of pipeline trenches under sidewalks and unpaved driveways shall be accomplished in the following manner:

1. The lower portion of the trench, from the pipe bedding to a point 12 inches above the top of the pipe, shall be backfilled with material free from rock, and acceptable to the Engineer or with crushed stone as specified in "Pipe Bedding". This material shall be placed in a manner to avoid displacement of the pipe. Compaction shall be accomplished by hand-tapping or by approved mechanical methods.

2. The middle portion of the trench, from a point 12" above the top of the pipe to a point 6" below the grade line, shall be backfilled with material free from large rock and acceptable to the Engineer. This material shall be placed and compacted in layers of approximately 6 inches. Water (puddling) may be used as required to obtain maximum compaction.

Upon approval of the Engineer, the Contractor may backfill the middle portion of the trench with crushed stone, fine gravel, or sand in lieu of materials which require compaction.

3. The upper portion of the trench shall be temporarily backfilled and maintained with crushed stone or gravel until such time as the sidewalk is constructed or the driveway surface is restored.

D. Method "C" - Backfilling Under Streets, Roads, and Paved Driveways:

Backfilling of pipeline trenches under streets, roads and paved driveways shall be accomplished in the following manner:

1. The lower portion of the trench from the pipe bedding to a point 6" below the bottom of the pavement or concrete sub-slab, shall be backfilled with # 9 crushed stone.

2. The upper portion of the trench, from a point 6" below the bottom of the pavement or concrete sub-slab to grade, shall be backfilled with a base course of dense graded aggregate. At such time that pavement replacement is accomplished, the excess base course shall be removed as required.

E. Trenches outside existing sidewalks, driveways, streets, and highways shall be backfilled in accordance with Method "A". Trenches within the limits of sidewalk and unpaved driveways shall be backfilled in accordance with Method "B". Trenches within the paving limits of existing streets, highways and driveways shall be backfilled in accordance with Method "C". All methods are shown on Sheet SD-2 of the Drawings. When directed by the Engineer, the Contractor shall wet backfill material to assure maximum compaction.

F. Before final acceptance, the Contractor will be required to level off all trenches or to bring the trench up to grade. The Contractor shall also remove from roadways, rights-of-ways and/or private property all excess earth or other materials resulting from construction.

G. In the event that pavement is not placed immediately following trench backfilling in streets and highways, the Contractor shall be responsible for maintaining the trench surface in a level condition at proper pavement grade at all times.



02502-8

### **3.06 SETTLEMENT OF TRENCHES**

A. Whenever lines are in, or cross, driveways and streets, the Contractor shall be responsible for any trench settlement which occurs within these rights-of-way within one year from the time of final acceptance of the work. If paving shall require replacement because of trench settlement within this time, it shall be replaced by the Contractor at no extra cost to the Owner. Repair of settlement damage shall meet the approval of the Owner and/or the State Department of Transportation.

### **3.07 CONCRETE THRUST BLOCKS, CRADLE, ANCHORS OR ENCASEMENT**

A. Concrete thrust blocks, cradle, anchors or encasement shall be placed where shown on the Drawings, required by the specifications, or as directed by the Engineer.

B. For cradle and encasement, concrete shall be 2000 psi and shall be mixed sufficiently wet to permit it to flow under the pipe to form a continuous bed.

C. For thrust blocks and anchors, concrete shall be 2000 psi, and shall be formed or be sufficiently stiff to maintain the forms indicated on the Details.

D. When tamping concrete, care shall be taken not to disturb the grade or line of the pipe or injure the joints. Concrete placed outside the specified limits or without authorization from the Engineer will not be subject to payment.

### **3.08 BITUMINOUS CONCRETE HIGHWAY, STREET AND DRIVEWAY REPLACEMENT**

A. The Contractor shall replace those sections of existing roads, streets and driveways required to be removed to install the pipe lines under this contract. He shall construct same to the original lines and grades and in such manner as to leave all such surfaces in fully as good or better condition than that which existed prior to the operations.

B. Prior to trenching, the pavement shall be scored or cut to straight edges at least twelve (12) inches outside each edge of the proposed trench to avoid unnecessary damage to the remainder of the paving. Edges of the existing pavement shall be re-cut and trimmed to square, straight edges after the pipeline has been installed and prior to placing the new base and pavement.

C. Backfilling of the trench shall be in accordance with Method "C" as described hereinbefore. Base course for the paving shall be dense graded crushed limestone furnished and placed in accordance with the current requirements of the Standard Specifications for Road and Bridge Construction of the Department of Transportation, to a depth of six (6) inches in roads and streets and four (4) inches in driveways.

D. A subslab of reinforced concrete shall be placed for state maintained highways as indicated on the Drawings. The subslab shall have a minimum thickness of 6 inches. Concrete for the subslab shall be 2500 psi, in accordance with the Details shown on the Drawings.

### **3.09 REMOVING AND REPLACING CONCRETE CURB AND GUTTER**

A. The Contractor shall remove the curb and gutter when encountered when required for laying the sewer. Only that portion of the curb and gutter needed to lay the sewer line shall be removed. Where concrete curb and gutter removed or disturbed during the construction work, it shall be replaced, using 3000 psi concrete, in fully as good or better condition than which existed prior to the Contractor's operation.

02502-9

### **3.10 REPLACEMENT OF EXISTING MAIL BOXES, CULVERTS, CLOTHES LINE POSTS, FENCES AND OTHER SUCH FACILITIES**

- A. Existing mail boxes, drainage culverts, clothes line posts, fences and the like shall not be damaged or disturbed unless necessary, in which case, they shall be replaced in as good condition as found as quickly as possible. Existing materials shall be reused in replacing such facilities when materials have not been damaged by the Contractor's operations. Existing facilities damaged by Contractor's operation shall be replaced with new materials of the same type at the Contractor's expense. Work in this category is not a pay item.
- B. Replacement of paved drainage ditches within highway right-of-way shall be accomplished in accordance with Department of Transportation specifications.

### **3.11 TESTING**

- A. All pressure piping (lines not laid to grade) shall be given a hydrostatic test of at least 1.5 times the normal operating pressure of the pipe (at its lowest elevation), but not to exceed the rated working pressure of the pipe or valves. Note: Engineer shall verify test pressure. Loss of pressure during the test shall not exceed 0 psi in a 4 hour period and 5 psi in a 24 hour period. Any test results that do not meet either of these requirements shall constitute a failure of the pressure test.
- B. Leakage in pipelines, when tested under the hydrostatic test described above, shall not exceed 10 gallons per 24 hours per inch of diameter per mile of pipe.
- C. Contractor shall furnish a recording gauge and water meter for measuring water used during leakage test and recording pressure charts during duration of test. Recording pressure charts shall be turned over to the Engineer at conclusion of tests. The pressure recording device shall be suitable for outside service, with a range from 0 200 psig, 24 hour spring wound clock, designed for 9 inch charts, and shall be approved by the Engineer.
- D. Pipelines shall be tested before backfilling at joints except where otherwise required by necessity or convenience.
- E. Duration of test shall be not less than four (4) hours where joints are exposed and not less than 24 hours where joints are covered.
- F. Where leaks are visible at exposed joints, evident on the surface where joints are covered, and/or identified by isolating a section of pipe, the joints shall be repaired and leakage must be minimized, regardless of total leakage as shown by test.
- G. All pipe, fittings, valves, and other materials found to be defective under test shall be removed and replaced at no additional expense to the Owner.
- H. Lines which fail to meet tests shall be repaired and retested as necessary until test requirements are complied with.
- I. Where nonmetallic joint compounds are used, pipelines should be held under normal operating pressure for at least three days before testing.
- J. The Owner will provide initial water for testing the pressure piping. Should the first test fail to pass, all additional water required for subsequent tests shall be furnished at the Contractor's expense.
- K. The cost of testing of pressure piping is incidental and is to be included in the Contractor's unit

02502-10

Contract Price.

### **3.12 CLEAN UP**

Upon completion of installation of the piping and appurtenances, the Contractor shall remove all debris and surplus construction materials resulting from the Work. The Contractor shall grade the ground along each side of pipe trenches in a uniform and neat manner leaving the construction area in a shape as near as possible to the original ground line.

END OF SECTION

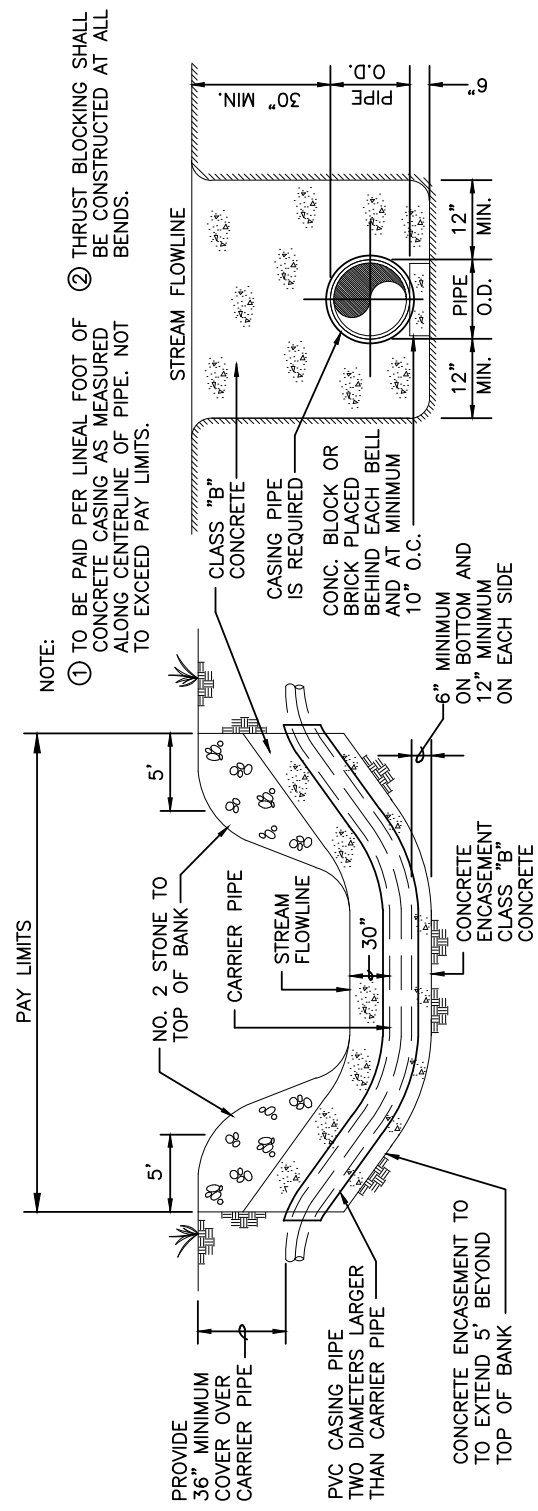

# FORCE MAIN CONCRETE ENCASEMENT

NOT TO SCALE

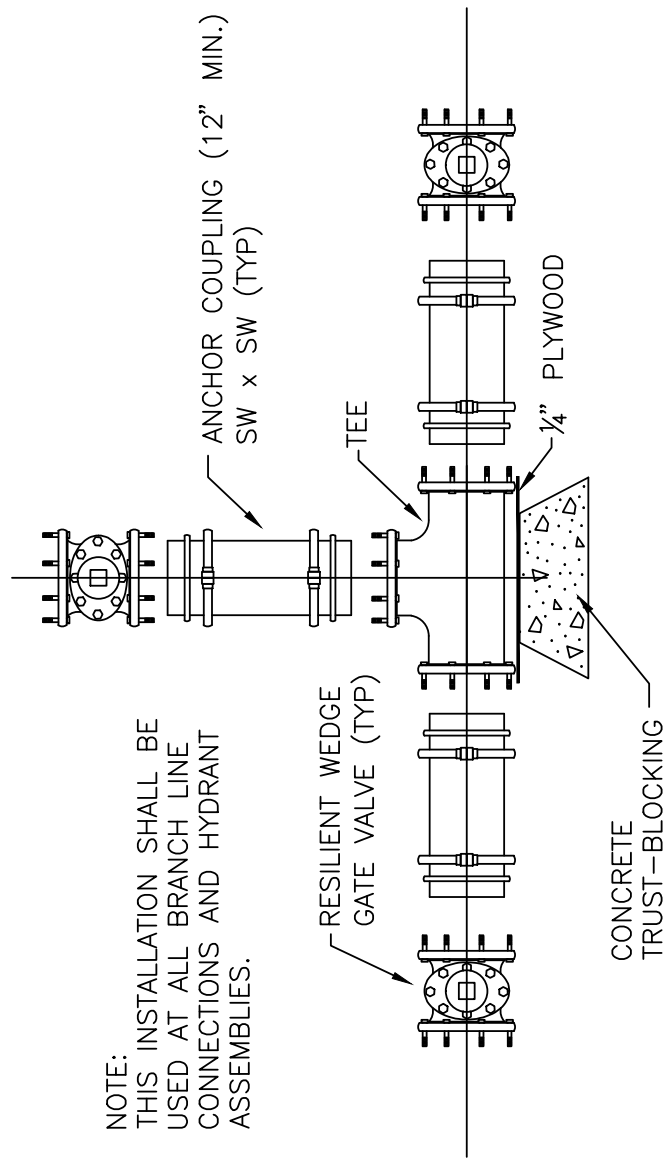

NOTE:  
THIS INSTALLATION SHALL BE  
USED AT ALL BRANCH LINE  
CONNECTIONS AND HYDRANT  
ASSEMBLIES.

# TEE INSTALLATION

NOT TO SCALE

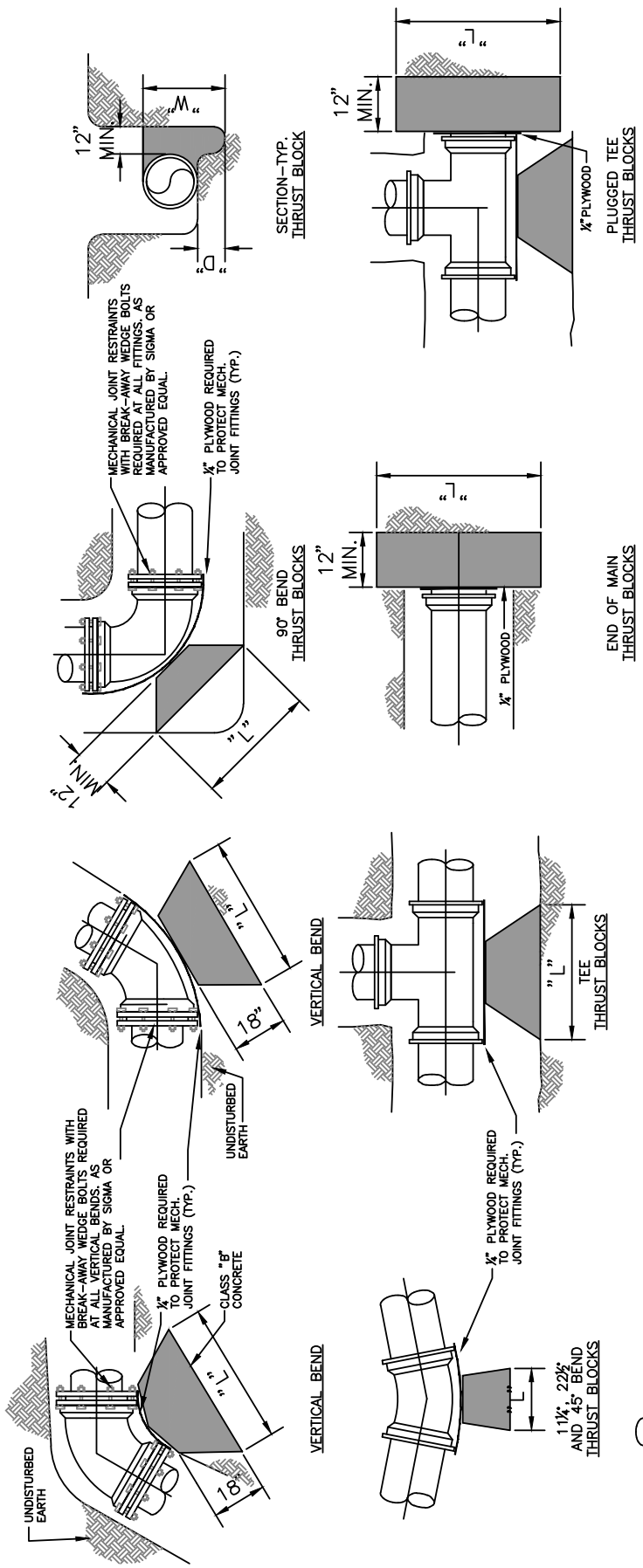

**THRUST BLOCK SCHEDULE - CLASS 200 PVC**

SOIL TYPE - SAND & GRAVEL  
 BEARING STRENGTH = 3000 PSF

PIPE SIZE	90° BEND			45° BEND			22 1/2° BEND			11 1/2° BEND			TEE & DEAD ENDS			
	MIN. AREA CONCRETE	D	W	MIN. AREA CONCRETE	D	W	MIN. AREA CONCRETE	D	W	MIN. AREA CONCRETE	D	W	MIN. AREA CONCRETE	D	W	L
4"	1.78	0.07	12"	1.00	0.04	12"	0.50	0.02	12"	0.25	0.01	6"	6"	6"	1.50	18"
6"	4.00	0.15	24"	2.25	0.08	12"	1.33	0.05	12"	0.56	0.01	6"	8"	8"	3.00	24"
8"	7.50	0.42	36"	4.00	0.22	18"	2.00	0.11	18"	1.00	0.04	12"	12"	12"	5.00	30"
10"	11.67	0.65	48"	6.25	0.35	18"	3.33	0.19	18"	2.00	0.07	12"	18"	16"	8.75	42"
12"	16.00	0.89	48"	9.00	0.50	18"	5.00	0.28	18"	3.00	0.10	12"	20"	16"	14.00	48"
14"	22.50	1.67	60"	12.25	0.81	24"	6.25	0.46	24"	4.00	0.18	18"	24"	20"	17.50	60"
16"	30.00	2.22	72"	16.00	1.19	24"	9.00	0.67	24"	5.00	0.22	18"	24"	24"	20.00	60"

(SEE THRUST BLOCK SCHEDULE FOR DIMENSIONS OF BLOCKING)  
**THRUST-BLOCKING DETAIL**

NOT TO SCALE

KyTC BMP Plan for Project PCN 5-000.00



**Kentucky Transportation Cabinet**

**Highway District 5**

**And**

\_\_\_\_\_ **(2), Construction**

**Kentucky Pollutant Discharge Elimination System**

**Permit KYR10**

**Best Management Practices (BMP) plan**

**Groundwater protection plan**

**For Highway Construction Activities**

**For**

**KY 44 Embankment Repair & Drainage**

**Improvements**

**Project: PCN 5-000.00**

## KyTC BMP Plan for Project PCN 5-000.00

### Project information

Note – (1) = Design (2) = Construction (3) = Contractor

1. Owner – Kentucky Transportation Cabinet, District 5
2. Resident Engineer: (2)
3. Contractor name: (2)  
Address: (2)  
  
Phone number: (2)  
Contact: (2)  
Contractors agent responsible for compliance with the KPDES permit requirements (3):
4. Project Control Number (2)
5. Route (Address): Old Mill Road, Mt. Washington, KY 40047
6. Latitude/Longitude (project mid-point): 38/2/15, 85/33/54
7. County (project mid-point): Bullitt
8. Project start date (date work will begin): (2)
9. Projected completion date: (2)



## KyTC BMP Plan for Project PCN 5–000.00

### A. Site description:

1. Nature of Construction Activity (from letting project description): Grade, Drain and Asphalt Surface
2. Order of major soil disturbing activities (2) and (3)
3. Projected volume of material to be moved: 761 CY
4. Estimate of total project area (acres): 0.61 Ac
5. Estimate of area to be disturbed (acres): 0.27 Ac
6. Post construction runoff coefficient will be included in the project drainage folder. Persons needing information pertaining to the runoff coefficient will contact the resident engineer to request this information. 0.48
7. Data describing existing soil condition: No Data Reported. The geologic mapping indicates that the bedrock at this site consists primarily of Laurel Dolomite. & (2)
8. Data describing existing discharge water quality (if any): None & (2)
9. Receiving water name: Tributary to McCullough Run
10. TMDLs and Pollutants of Concern in Receiving Waters: No TMDL Data Reported (DEA)
11. Site map – Project layout sheet plus the erosion control sheets in the project plans that depict Disturbed Drainage Areas (DDAs) and related information. These sheets depict the existing project conditions with areas delineated by DDA (drainage area bounded by watershed breaks and right of way limits), the storm water discharge locations (either as a point discharge or as overland flow) and the areas that drain to each discharge point. These plans define the limits of areas to be disturbed and the location of control measures. Controls will be either site specific as designated by the designer or will be annotated by the contractor and resident engineer before disturbance commences. The project layout sheet shows the surface waters and wetlands.
12. Potential sources of pollutants:

The primary source of pollutants is solids that are mobilized during storm events. Other sources of pollutants include oil/fuel/grease from servicing

## KyTC BMP Plan for Project PCN 5-000.00

and operating construction equipment, concrete washout water, sanitary wastes and trash/debris. (3)

### **B. Sediment and Erosion Control Measures:**

1. Plans for highway construction projects will include erosion control sheets that depict Disturbed Drainage Areas (DDAs) and related information. These plan sheets will show the existing project conditions with areas delineated by DDA within the right of way limits, the discharge points and the areas that drain to each discharge point. Project managers and designers will analyze the DDAs and identify Best Management Practices (BMPs) that are site specific. The balance of the BMPs for the project will be listed in the bid documents for selection and use by the contractor on the project with approval by the resident engineer.

Projects that do not have DDAs annotated on the erosion control sheets will employ the same concepts for development and managing BMP plans.

2. Following award of the contract, the contractor and resident engineer will annotate the erosion control sheets showing location and type of BMPs for each of the DDAs that will be disturbed at the outset of the project. This annotation will be accompanied by an order of work that reflects the order or sequence of major soil moving activities. The remaining DDAs are to be designated as "Do Not Disturb" until the contractor and resident engineer prepare the plan for BMPs to be employed. The initial BMP's shall be for the first phase (generally Clearing and Grubbing) and shall be modified as needed as the project changes phases. The BMP Plan will be modified to reflect disturbance in additional DDA's as the work progresses. All DDA's will have adequate BMP's in place before being disturbed.
3. As DDAs are prepared for construction, the following will be addressed for the project as a whole or for each DDA as appropriate:
  - Construction Access – This is the first land-disturbing activity. As soon as construction begins, bare areas will be stabilized with gravel and temporary mulch and/or vegetation.
  - At the beginning of the project, all DDAs for the project will be inspected for areas that are a source of storm water pollutants. Areas that are a source of pollutants will receive appropriate cover or BMPs to arrest the introduction of pollutants into storm water. Areas that have not been opened by the contractor will be

## KyTC BMP Plan for Project PCN 5-000.00

- inspected periodically (once per month) to determine if there is a need to employ BMPs to keep pollutants from entering storm water.
- Clearing and Grubbing – The following BMP's will be considered and used where appropriate.
    - Leaving areas undisturbed when possible.
    - Silt basins to provide silt volume for large areas.
    - Silt Traps Type A for small areas.
    - Silt Traps Type C in front of existing and drop inlets which are to be saved
    - Diversion ditches to catch sheet runoff and carry it to basins or traps or to divert it around areas to be disturbed.
    - Brush and/or other barriers to slow and/or divert runoff.
    - Silt fences to catch sheet runoff on short slopes. For longer slopes, multiple rows of silt fence may be considered.
    - Temporary Mulch for areas which are not feasible for the fore mentioned types of protections.
    - Non-standard or innovative methods.
  - Cut & Fill and placement of drainage structures - The BMP Plan will be modified to show additional BMP's such as:
    - Silt Traps Type B in ditches and/or drainways as they are completed
    - Silt Traps Type C in front of pipes after they are placed
    - Channel Lining
    - Erosion Control Blanket
    - Temporary mulch and/or seeding for areas where construction activities will be ceased for 21 days or more.
    - Non-standard or innovative methods
  - Profile and X-Section in place – The BMP Plan will be modified to show elimination of BMP's which had to be removed and the addition of new BMP's as the roadway was shaped. Probably changes include:
    - Silt Trap Type A, Brush and/or other barriers, Temporary Mulch, and any other BMP which had to be removed for final grading to take place.
    - Additional Silt Traps Type B and Type C to be placed as final drainage patterns are put in place.
    - Additional Channel Lining and/or Erosion Control Blanket.
    - Temporary Mulch for areas where Permanent Seeding and Protection cannot be done within 21 days.
    - Special BMP's such as Karst Policy
  - Finish Work (Paving, Seeding, Protect, etc.) – A final BMP Plan will result from modifications during this phase of construction. Probably changes include:
    - Removal of Silt Traps Type B from ditches and drainways if they are protected with other BMP's which are sufficient to

## KyTC BMP Plan for Project PCN 5-000.00

control erosion, i.e. Erosion Control Blanket or Permanent Seeding and Protection on moderate grades.

- Permanent Seeding and Protection
  - Placing Sod
  - Planting trees and/or shrubs where they are included in the project
- BMP's including Storm Water Management Devices such as velocity dissipation devices and Karst policy BMP's to be installed during construction to control the pollutants in storm water discharges that will occur after construction has been completed are : *This project does not include storm water BMPs or flow controls for post-construction use.*

### **C. Other Control Measures**

1. No solid materials, including building materials, shall be discharged to waters of the commonwealth, except as authorized by a Section 404 permit.
2. Waste Materials

All waste materials that may leach pollutants (paint and paint containers, caulk tubes, oil/grease containers, liquids of any kind, soluble materials, etc.) will be collected and stored in appropriate covered waste containers. Waste containers shall be removed from the project site on a sufficiently frequent basis as to not allow wastes to become a source of pollution. All personnel will be instructed regarding the correct procedure for waste disposal. Wastes will be disposed in accordance with appropriate regulations. Notices stating these practices will be posted in the office.

3. Hazardous Waste

All hazardous waste materials will be managed and disposed of in the manner specified by local or state regulation. The contractor shall notify the Resident Engineer if there any hazardous wastes being generated at the project site and how these wastes are being managed. Site personnel will be instructed with regard to proper storage and handling of hazardous wastes when required. The Transportation Cabinet will file for generator, registration when appropriate, with the Division of Waste Management and advise the contractor regarding waste management requirements.

4. Spill Prevention

The following material management practices will be used to reduce the risk of spills or other exposure of materials and substances to the weather and/or runoff.

## KyTC BMP Plan for Project PCN 5-000.00

### ➤ **Good Housekeeping:**

The following good housekeeping practices will be followed onsite during the construction project.

- An effort will be made to store only enough product required to do the job
- All materials stored onsite will be stored in a neat, orderly manner in their appropriate containers and, if possible, under a roof or other enclosure
- Products will be kept in their original containers with the original manufacturer's label
- Substances will not be mixed with one another unless recommended by the manufacturer
- Whenever possible, all of the product will be used up before disposing of the container
- Manufacturers' recommendations for proper use and disposal will be followed
- The site contractor will inspect daily to ensure proper use and disposal of materials onsite

### ➤ **Hazardous Products:**

These practices will be used to reduce the risks associated with any and all hazardous materials.

- Products will be kept in original containers unless they are not resealable
- Original labels and material safety data sheets (MSDS) will be reviewed and retained
- Contractor will follow procedures recommended by the manufacturer when handling hazardous materials
- If surplus product must be disposed of, manufacturers' or state/local recommended methods for proper disposal will be followed

**The following product-specific practices will be followed onsite:**

### ➤ **Petroleum Products:**

Vehicles and equipment that are fueled and maintained on site will be monitored for leaks, and receive regular preventative maintenance to reduce the chance of leakage. Petroleum products onsite will be stored in tightly sealed containers, which are clearly labeled and will be protected from exposure to weather.

The contractor shall prepare an Oil Pollution Spill Prevention Control and Countermeasure plan when the project that involves the storage of petroleum

## KyTC BMP Plan for Project PCN 5-000.00

products in 55 gallon or larger containers with a total combined storage capacity of 1,320 gallons. This is a requirement of 40 CFR 112.

This project (will / will not) (3) have over 1,320 gallons of petroleum products with a total capacity, sum of all containers 55 gallon capacity and larger.

### ➤ **Fertilizers:**

Fertilizers will be applied at rates prescribed by the contract, standard specifications or as directed by the resident engineer. Once applied, fertilizer will be covered with mulch or blankets or worked into the soil to limit exposure to storm water. Storage will be in a covered shed. The contents of any partially used bags of fertilizer will be transferred to a sealable plastic bin to avoid spills.

### ➤ **Paints:**

All containers will be tightly sealed and stored indoors or under roof when not being used. Excess paint or paint wash water will not be discharged to the drainage or storm sewer system but will be properly disposed of according to manufacturers' instructions or state and local regulations.

### ➤ **Concrete Truck Washout:**

Concrete truck mixers and chutes will not be washed on pavement, near storm drain inlets, or within 75 feet of any ditch, stream, wetland, lake, or sinkhole. Where possible, excess concrete and wash water will be discharged to areas prepared for pouring new concrete, flat areas to be paved that are away from ditches or drainage system features, or other locations that will not drain off site. Where this approach is not possible, a shallow earthen wash basin will be excavated away from ditches to receive the wash water

### ➤ **Spill Control Practices**

In addition to the good housekeeping and material management practices discussed in the previous sections of this plan, the following practices will be followed for spill prevention and cleanup:

- Manufacturers' recommended methods for spill cleanup will be clearly posted. All personnel will be made aware of procedures and the location of the information and cleanup supplies.
- Materials and equipment necessary for spill cleanup will be kept in the material storage area. Equipment and materials will include as appropriate, brooms, dust pans, mops, rags, gloves, oil absorbents, sand, sawdust, and plastic and metal trash containers.
- All spills will be cleaned up immediately after discovery.

## KyTC BMP Plan for Project PCN 5-000.00

- The spill area will be kept well ventilated and personnel will wear appropriate protective clothing to prevent injury from contact with a hazardous substance.
- Spills of toxic or hazardous material will be reported to the appropriate state/local agency as required by KRS 224 and applicable federal law.
- The spill prevention plan will be adjusted as needed to prevent spills from reoccurring and improve spill response and cleanup.
- Spills of products will be cleaned up promptly. Wastes from spill clean up will be disposed in accordance with appropriate regulations.

### **D. Other State and Local Plans**

This BMP plan shall include any requirements specified in sediment and erosion control plans, storm water management plans or permits that have been approved by other state or local officials. Upon submittal of the NOI, other requirements for surface water protection are incorporated by reference into and are enforceable under this permit (even if they are not specifically included in this BMP plan). This provision does not apply to master or comprehensive plans, non-enforceable guidelines or technical guidance documents that are not identified in a specific plan or permit issued for the construction site by state or local officials. *There are other local (MS4) requirements that are being added to this project.*

### **E. Maintenance**

1. The BMP plan shall include a clear description of the maintenance procedures necessary to keep the control measures in good and effective operating condition.
- Maintenance of BMPs during construction shall be a result of weekly and post rain event inspections with action being taken by the contractor to correct deficiencies.
  - Post Construction maintenance will be a function of normal highway maintenance operations. Following final project acceptance by the cabinet, district highway crews will be responsible for identification and correction of deficiencies regarding ground cover and cleaning of storm water BMPs. The project manager shall identify any BMPs that will be for the purpose of post construction storm water management with specific guidance for any non-routine maintenance. *There are no such BMP's.*

## KyTC BMP Plan for Project PCN 5–000.00

### **F. Inspections**

Inspection and maintenance practices that will be used to maintain erosion and sediment controls:

- All erosion prevention and sediment control measures will be inspected at least once each week and following any rain of one-half inch or more.
- Inspections will be conducted by individuals that have received KyTC Grade Level II training or other qualification as prescribed by the cabinet that includes instruction concerning sediment and erosion control.
- Inspection reports will be written, signed, dated, and kept on file.
- Areas at final grade will be seeded and mulched within 14 days.
- Areas that are not at final grade where construction has ceased for a period of 21 days or longer and soil stock piles shall receive temporary mulch no later than 14 days from the last construction activity in that area.
- All measures will be maintained in good working order; if a repair is necessary, it will be initiated within 24 hours of being reported.
- Built-up sediment will be removed from behind the silt fence before it has reached halfway up the height of the fence.
- Silt fences will be inspected for bypassing, overtopping, undercutting, depth of sediment, tears, and to ensure attachment to secure posts.
- Sediment basins will be inspected for depth of sediment, and built-up sediment will be removed when it reaches 70 percent of the design capacity and at the end of the job.
- Diversion dikes and berms will be inspected and any breaches promptly repaired. Areas that are eroding or scouring will be repaired and re-seeded / mulched as needed.
- Temporary and permanent seeding and mulching will be inspected for bare spots, washouts, and healthy growth. Bare or eroded areas will be repaired as needed.
- All material storage and equipment servicing areas that involve the management of bulk liquids, fuels, and bulk solids will be inspected weekly for conditions that represent a release or possible release of pollutants to the environment.

### **G. Non – Storm Water discharges**

It is expected that non-storm water discharges may occur from the site during the construction period. Examples of non-storm water discharges include:



## KyTC BMP Plan for Project PCN 5-000.00

- Water from water line flushings.
- Water from cleaning concrete trucks and equipment.
- Pavement wash waters (where no spills or leaks of toxic or hazardous materials have occurred).
- Uncontaminated groundwater and rain water (from dewatering during excavation).

All non-storm water discharges will be directed to the sediment basin or to a filter fence enclosure in a flat vegetated infiltration area or be filtered via another approved commercial product.

### H. Groundwater Protection Plan (3)

This plan serves as the groundwater protection plan as required by 401 KAR 5:037.

- Contractors statement: (3)

The following activities, as enumerated by 401 KAR 5:037 Section 2 that require the preparation and implementation of a groundwater protection plan, will or may be may be conducted as part of this construction project:

\_\_\_\_\_ 2. (e) land treatment or land disposal of a pollutant;

\_\_\_\_\_ 2. (f) Storing, ..., or related handling of hazardous waste, solid waste or special waste, ..., in tanks, drums, or other containers, or in piles, (This does not include wastes managed in a container placed for collection and removal of municipal solid waste for disposal off site);

\_\_\_\_\_ 2. (g) .... Handling of materials in bulk quantities (equal or greater than 55 gallons or 100 pounds net dry weight transported held in an individual container) that, if released to the environment, would be a pollutant;

\_\_\_\_\_ 2. (j) Storing or related handling of road oils, dust suppressants, ....., at a central location;

\_\_\_\_\_ 2. (k) Application or related handling of road oils, dust suppressants or deicing materials, (does not include use of chloride-based deicing materials applied to roads or parking lots);

\_\_\_\_\_ 2. (m) Installation, construction, operation, or abandonment of wells, bore holes, or core holes, (this does not include bore holes for the purpose of explosive demolition);

## KyTC BMP Plan for Project PCN 5-000.00

Or, check the following only if there are no qualifying activities

\_\_\_\_\_ There are no activities for this project as listed in 401 KAR 5:037 Section 2 that require the preparation and implementation of a groundwater protection plan.

The contractor is responsible for the preparation of a plan that addresses the

401 KAR 5:037 Section 3. (3) Elements of site specific groundwater protection plan:

- (a) General information about this project is covered in the Project information;
- (b) Activities that require a groundwater protection plan have been identified above;
- (c) Practices that will protect groundwater from pollution are addressed in section C. Other control measures.
- (d) Implementation schedule – all practices required to prevent pollution of groundwater are to be in place prior to conducting the activity;
- (e) Training is required as a part of the ground water protection plan. All employees of the contractor, sub-contractor and resident engineer personnel will be trained to understand the nature and requirements of this plan as they pertain to their job function(s). Training will be accomplished within one week of employment and annually thereafter. A record of training will be maintained by the contractor with a copy provide to the resident engineer.
- (f) Areas of the project and groundwater plan activities will be inspected as part of the weekly sediment and erosion control inspections
- (g) Certification (see signature page.)



KyTC BMP Plan for Project PCN 5-000.00

**Sub-Contractor Certification**

The following sub-contractor shall be made aware of the BMP plan and responsible for implementation of BMPs identified in this plan as follows:

Subcontractor

Name:  
Address:  
Address:  
  
Phone:

The part of BMP plan this subcontractor is responsible to implement is:

I certify under penalty of law that I understand the terms and conditions of the general Kentucky Pollutant Discharge Elimination System permit that authorizes the storm water discharges, the BMP plan that has been developed to manage the quality of water to be discharged as a result of storm events associated with the construction site activity and management of non-storm water pollutant sources identified as part of this certification.

Signed \_\_\_\_\_ title \_\_\_\_\_, \_\_\_\_\_  
Typed or printed name<sup>1</sup> signature

1. Sub Contractor Note: to be signed by a person who is the owner, a responsible corporate officer, a general partner or the proprietor or a person designated to have the authority to sign reports by such a person in accordance with 401 KAR 5:060 Section 9. This delegation shall be in writing to: Manager, KPDES Branch, Division of Water, 14 Reilly Road, Frankfort Kentucky 40601. Reference the Project Control Number (PCN) and KPDES number when one has been issued.

**PART II**  
**SPECIFICATIONS AND STANDARD DRAWINGS**

### **SPECIFICATIONS REFERENCE**

Any reference in the plans or proposal to previous editions of the *Standard Specifications for Road and Bridge Construction* and *Standard Drawings* are superseded by *Standard Specifications for Road and Bridge Construction, Edition of 2019* and *Standard Drawings, Edition of 2016*.

## **SUPPLEMENTAL SPECIFICATIONS**

The contractor shall use the Supplemental Specifications that are effective at the time of letting.  
The Supplemental Specifications can be found at the following link:

<http://transportation.ky.gov/Construction/Pages/Kentucky-Standard-Specifications.aspx>

## **PART III**

### **EMPLOYMENT, WAGE AND RECORD REQUIREMENTS**



**TRANSPORTATION CABINET  
DEPARTMENT OF HIGHWAYS**

**LABOR AND WAGE REQUIREMENTS  
APPLICABLE TO OTHER THAN FEDERAL-AID SYSTEM PROJECTS**

- I. Application
- II. Nondiscrimination of Employees (KRS 344)

**I. APPLICATION**

1. These contract provisions shall apply to all work performed on the contract by the contractor with his own organization and with the assistance of workmen under his immediate superintendence and to all work performed on the contract by piecework, station work or by subcontract. The contractor's organization shall be construed to include only workmen employed and paid directly by the contractor and equipment owned or rented by him, with or without operators.

2. The contractor shall insert in each of his subcontracts all of the stipulations contained in these Required Provisions and such other stipulations as may be required.

3. A breach of any of the stipulations contained in these Required Provisions may be grounds for termination of the contract.

3. If the contractor is in control of apprenticeship or other training or retraining, including on-the-job training programs, he shall not discriminate against an individual because of his race, color, religion, national origin, sex, disability or age forty (40) and over, in admission to, or employment in any program established to provide apprenticeship or other training.

4. The contractor will send to each labor union or representative of workers with which he has a collective bargaining agreement or other contract or understanding, a notice to be provided advising the said labor union or workers' representative of the contractor's commitments under this section, and shall post copies of the notice in conspicuous places available to employees and applicants for employment. The contractor will take such action with respect to any subcontract or purchase order as the administrating agency may direct as a means of enforcing such provisions, including sanctions for non-compliance.

Revised: January 25, 2017

**II. NONDISCRIMINATION OF EMPLOYEES**

**AN ACT OF THE KENTUCKY  
GENERAL ASSEMBLY TO PREVENT  
DISCRIMINATION IN EMPLOYMENT  
KRS CHAPTER 344  
EFFECTIVE JUNE 16, 1972**

The contract on this project, in accordance with KRS Chapter 344, provides that during the performance of this contract, the contractor agrees as follows:

1. The contractor shall not fail or refuse to hire, or shall not discharge any individual, or otherwise discriminate against an individual with respect to his compensation, terms, conditions, or privileges of employment, because of such individual's race, color, religion, national origin, sex, disability or age (forty and above); or limit, segregate, or classify his employees in any way which would deprive or tend to deprive an individual of employment opportunities or otherwise adversely affect his status as an employee, because of such individual's race, color, religion, national origin, sex, disability or age forty (40) and over. The contractor agrees to post in conspicuous places, available to employees and applicants for employment, notices to be provided setting forth the provisions of this nondiscrimination clause.

2. The contractor shall not print or publish or cause to be printed or published a notice or advertisement relating to employment by such an employer or membership in or any classification or referral for employment by the employment agency, indicating any preference, limitation, specification, or discrimination, based on race, color, religion, national origin, sex, or age forty (40) and over, or because the person is a qualified individual with a disability, except that such a notice or advertisement may indicate a preference, limitation, or specification based on religion, national origin, sex, or age forty (40) and over, or because the person is a qualified individual with a disability, when religion, national origin, sex, or age forty (40) and over, or because the person is a qualified individual with a disability, is a bona fide occupational qualification for employment.

## EXECUTIVE BRANCH CODE OF ETHICS

In the 1992 regular legislative session, the General Assembly passed and Governor Brereton Jones signed Senate Bill 63 (codified as KRS 11A), the Executive Branch Code of Ethics, which states, in part:

KRS 11A.040 (7) provides:

No present or former public servant shall, within six (6) months following termination of his office or employment, accept employment, compensation, or other economic benefit from any person or business that contracts or does business with, or is regulated by, the state in matters in which he was directly involved during the last thirty-six (36) months of his tenure. This provision shall not prohibit an individual from returning to the same business, firm, occupation, or profession in which he was involved prior to taking office or beginning his term of employment, or for which he received, prior to his state employment, a professional degree or license, provided that, for a period of six (6) months, he personally refrains from working on any matter in which he was directly involved during the last thirty-six (36) months of his tenure in state government. This subsection shall not prohibit the performance of ministerial functions, including but not limited to filing tax returns, filing applications for permits or licenses, or filing incorporation papers, nor shall it prohibit the former officer or public servant from receiving public funds disbursed through entitlement programs.

KRS 11A.040 (9) states:

A former public servant shall not represent a person or business before a state agency in a matter in which the former public servant was directly involved during the last thirty-six (36) months of his tenure, for a period of one (1) year after the latter of:

- a) The date of leaving office or termination of employment; or
- b) The date the term of office expires to which the public servant was elected.

This law is intended to promote public confidence in the integrity of state government and to declare as public policy the idea that state employees should view their work as a public trust and not as a way to obtain private benefits.

If you have worked for the executive branch of state government within the past six months, you may be subject to the law's prohibitions. The law's applicability may be different if you hold elected office or are contemplating representation of another before a state agency.

Also, if you are affiliated with a firm which does business with the state and which employs former state executive-branch employees, you should be aware that the law may apply to them.

In case of doubt, the law permits you to request an advisory opinion from the Executive Branch Ethics Commission, 3 Fountain Place, Frankfort, Kentucky 40601; telephone (502) 564-7954.

Revised: January 27, 2017

### **Kentucky Equal Employment Opportunity Act of 1978**

The requirements of the Kentucky Equal Employment Opportunity Act of 1978 (KRS 45.560-45.640) shall apply to this Contract. The apparent low Bidder will be required to submit EEO forms to the Division of Construction Procurement, which will then forward to the Finance and Administration Cabinet for review and approval. No award will become effective until all forms are submitted and EEO/CC has certified compliance. The required EEO forms are as follows:

- EEO-1: Employer Information Report
- Affidavit of Intent to Comply
- Employee Data Sheet
- Subcontractor Report

These forms are available on the Finance and Administration's web page under ***Vendor Information, Standard Attachments and General Terms*** at the following address:  
**<https://www.eProcurement.ky.gov>**.

Bidders currently certified as being in compliance by the Finance and Administration Cabinet may submit a copy of their approval letter in lieu of the referenced EEO forms.

For questions or assistance please contact the Finance and Administration Cabinet by email at **[finance.contractcompliance@ky.gov](mailto:finance.contractcompliance@ky.gov)** or by phone at 502-564-2874.

# EMPLOYEE RIGHTS UNDER THE FAIR LABOR STANDARDS ACT

THE UNITED STATES DEPARTMENT OF LABOR WAGE AND HOUR DIVISION

## FEDERAL MINIMUM WAGE

# \$7.25

 PER HOUR

BEGINNING JULY 24, 2009

**OVERTIME PAY** At least 1½ times your regular rate of pay for all hours worked over 40 in a workweek.

**CHILD LABOR** An employee must be at least **16** years old to work in most non-farm jobs and at least **18** to work in non-farm jobs declared hazardous by the Secretary of Labor.

Youths **14** and **15** years old may work outside school hours in various non-manufacturing, non-mining, non-hazardous jobs under the following conditions:

**No more than**

- **3** hours on a school day or **18** hours in a school week;
- **8** hours on a non-school day or **40** hours in a non-school week.

Also, work may not begin before **7 a.m.** or end after **7 p.m.**, except from June 1 through Labor Day, when evening hours are extended to **9 p.m.** Different rules apply in agricultural employment.

**TIP CREDIT** Employers of “tipped employees” must pay a cash wage of at least \$2.13 per hour if they claim a tip credit against their minimum wage obligation. If an employee’s tips combined with the employer’s cash wage of at least \$2.13 per hour do not equal the minimum hourly wage, the employer must make up the difference. Certain other conditions must also be met.

**ENFORCEMENT** The Department of Labor may recover back wages either administratively or through court action, for the employees that have been underpaid in violation of the law. Violations may result in civil or criminal action.

Employers may be assessed civil money penalties of up to \$1,100 for each willful or repeated violation of the minimum wage or overtime pay provisions of the law and up to \$11,000 for each employee who is the subject of a violation of the Act’s child labor provisions. In addition, a civil money penalty of up to \$50,000 may be assessed for each child labor violation that causes the death or serious injury of any minor employee, and such assessments may be doubled, up to \$100,000, when the violations are determined to be willful or repeated. The law also prohibits discriminating against or discharging workers who file a complaint or participate in any proceeding under the Act.

### ADDITIONAL INFORMATION

- Certain occupations and establishments are exempt from the minimum wage and/or overtime pay provisions.
- Special provisions apply to workers in American Samoa and the Commonwealth of the Northern Mariana Islands.
- Some state laws provide greater employee protections; employers must comply with both.
- The law requires employers to display this poster where employees can readily see it.
- Employees under 20 years of age may be paid \$4.25 per hour during their first 90 consecutive calendar days of employment with an employer.
- Certain full-time students, student learners, apprentices, and workers with disabilities may be paid less than the minimum wage under special certificates issued by the Department of Labor.

For additional information:



# 1-866-4-USWAGE

(1-866-487-9243) TTY: 1-877-889-5627



# WWW.WAGEHOUR.DOL.GOV

**PART IV**  
**INSURANCE**

Refer to  
*Kentucky Standard Specifications for Road and Bridge Construction,*  
current edition

**PART V**  
**BID ITEMS**

### PROPOSAL BID ITEMS

191035

Page 1 of 2

Report Date 7/26/19

#### Section: 0001 - PAVING

LINE	BID CODE	ALT	DESCRIPTION	QUANTITY	UNIT	UNIT PRIC	FP	AMOUNT
0010	00003		CRUSHED STONE BASE 7.75"	38.00	TON		\$	
0020	00078		CRUSHED AGGREGATE SIZE NO 2	75.00	TON		\$	
0030	00214		CL3 ASPH BASE 1.00D PG64-22 6.75"	86.00	TON		\$	
0040	00356		ASPHALT MATERIAL FOR TACK	.16	TON		\$	
0050	22906ES403		CL3 ASPH SURF 0.38A PG64-22 1.25"	11.00	TON		\$	

#### Section: 0002 - ROADWAY

LINE	BID CODE	ALT	DESCRIPTION	QUANTITY	UNIT	UNIT PRIC	FP	AMOUNT
0060	01310		REMOVE PIPE	63.00	LF		\$	
0070	02014		BARRICADE-TYPE III	2.00	EACH		\$	
0080	02159		TEMP DITCH	140.00	LF		\$	
0090	02230		EMBANKMENT IN PLACE	802.00	CUYD		\$	
0100	02381		REMOVE GUARDRAIL	250.00	LF		\$	
0110	02483		CHANNEL LINING CLASS II	59.00	TON		\$	
0120	02545		CLEARING AND GRUBBING 0.27 ACRES	1.00	LS		\$	
0130	02562		TEMPORARY SIGNS	106.00	SQFT		\$	
0140	02585		EDGE KEY	12.00	LF		\$	
0150	02596		FABRIC-GEOTEXTILE TYPE I	93.00	SQYD		\$	
0160	02599		FABRIC-GEOTEXTILE TYPE IV	144.00	SQYD		\$	
0170	02600		FABRIC GEOTEXTILE TY IV FOR PIPE	342.00	SQYD	\$2.00	\$	\$684.00
0180	02650		MAINTAIN & CONTROL TRAFFIC	1.00	LS		\$	
0190	02701		TEMP SILT FENCE	336.00	LF		\$	
0200	02703		SILT TRAP TYPE A	1.00	EACH		\$	
0210	02704		SILT TRAP TYPE B	3.00	EACH		\$	
0220	02705		SILT TRAP TYPE C	4.00	EACH		\$	
0230	02706		CLEAN SILT TRAP TYPE A	1.00	EACH		\$	
0240	02707		CLEAN SILT TRAP TYPE B	3.00	EACH		\$	
0250	02708		CLEAN SILT TRAP TYPE C	4.00	EACH		\$	
0260	02726		STAKING	1.00	LS		\$	
0270	05950		EROSION CONTROL BLANKET	600.00	SQYD		\$	
0280	05963		INITIAL FERTILIZER	.01	TON		\$	
0290	05964		MAINTENANCE FERTILIZER	.05	TON		\$	
0300	05985		SEEDING AND PROTECTION	1,000.00	SQYD		\$	
0310	05992		AGRICULTURAL LIMESTONE	.62	TON		\$	
0320	06514		PAVE STRIPING-PERM PAINT-4 IN	800.00	LF		\$	
0330	20366NN		REPLACE GRATE	2.00	EACH		\$	
0340	21289ED		LONGITUDINAL EDGE KEY	160.00	LF		\$	
0350	23274EN11F		TURF REINFORCEMENT MAT 1	28.00	SQYD		\$	

#### Section: 0003 - DRAINAGE

### PROPOSAL BID ITEMS

191035

Page 2 of 2

Report Date 7/26/19

LINE	BID CODE	ALT	DESCRIPTION	QUANTITY	UNIT	UNIT PRIC	FP	AMOUNT
0360	00440		ENTRANCE PIPE-15 IN	134.00	LF		\$	
0370	00499		CULVERT PIPE-48 IN EQUIV	37.00	LF		\$	
0380	01217		PIPE CULVERT HEADWALL-48 IN EQUIV	1.00	EACH		\$	
0390	01650		JUNCTION BOX	1.00	EACH		\$	
0400	02403		REMOVE CONCRETE MASONRY	1.00	CUYD		\$	
0410	02625		REMOVE HEADWALL	1.00	EACH		\$	

#### Section: 0004 - SEWER

LINE	BID CODE	ALT	DESCRIPTION	QUANTITY	UNIT	UNIT PRIC	FP	AMOUNT
0420	15012		S ENCASMENT CONCRETE	70.00	LF		\$	
0430	15062		S FORCE MAIN PVC 10 INCH	420.00	LF		\$	
0440	15076		S FORCE MAIN TIE-IN 10 INCH	2.00	EACH		\$	

#### Section: 0005 - DEMOBILIZATION &/OR MOBILIZATION

LINE	BID CODE	ALT	DESCRIPTION	QUANTITY	UNIT	UNIT PRIC	FP	AMOUNT
0450	02569		DEMOBILIZATION	1.00	LS		\$	