



**CALL NO. 203**

**CONTRACT ID. 194205**

**NELSON - WASHINGTON - TAYLOR COUNTIES**

**FED/STATE PROJECT NUMBER 121GR19T005-HSIP**

**DESCRIPTION IMPROVEMENTS AT VARIOUS INTERSECTIONS IN DISTRICT 4**

**WORK TYPE SIGNS-LIGHTING-SIGNALS**

**PRIMARY COMPLETION DATE 10/31/2019**

**LETTING DATE: February 22,2019**

Sealed Bids will be received electronically through the Bid Express bidding service until 10:00 AM EASTERN STANDARD TIME February 22,2019. Bids will be publicly announced at 10:00 AM EASTERN STANDARD TIME.

**NO PLANS ASSOCIATED WITH THIS PROJECT.**

**DBE CERTIFICATION REQUIRED - 0%**

**REQUIRED BID PROPOSAL GUARANTY:** Not less than 5% of the total bid.

## TABLE OF CONTENTS

PART I	SCOPE OF WORK
	<ul style="list-style-type: none"><li>• PROJECT(S), COMPLETION DATE(S), &amp; LIQUIDATED DAMAGES</li><li>• CONTRACT NOTES</li><li>• FEDERAL CONTRACT NOTES</li><li>• WASTE AND BORROW SITES</li><li>• COORDINATION OF WORK WITH OTHER CONTRACTS</li><li>• SIDEWALK RAMPS &amp; DETECTABLE WARNINGS</li><li>• TRAFFIC CONTROL PLAN</li><li>• TRAFFIC SIGNAL LOOP DETECTORS</li><li>• RIGHT OF WAY NOTES</li><li>• UTILITY IMPACT &amp; RAIL CERTIFICATION NOTES</li><li>• SKETCH MAP(S)</li><li>• MATERIAL SUMMARY</li><li>• DETAIL SHEET(S)</li></ul>
PART II	SPECIFICATIONS AND STANDARD DRAWINGS
	<ul style="list-style-type: none"><li>• SPECIFICATIONS REFERENCE</li><li>• SUPPLEMENTAL SPECIFICATION</li><li>• 2016 STANDARD DRAWINGS THAT APPLY</li><li>• DELINEATORS FOR GUARDRAIL</li><li>• TYPICAL MARKINGS FOR TURN LANES</li><li>• TYPICAL MARKINGS AT SIGNALIZED INTERSECTIONS</li><li>• TYPICAL MARKINGS FOR ISLANDS AND MEDIANS</li></ul>
PART III	EMPLOYMENT, WAGE AND RECORD REQUIREMENTS
	<ul style="list-style-type: none"><li>• FEDERAL-AID CONSTRUCTION CONTRACTS - FHWA 1273</li><li>• NONDISCRIMINATION OF EMPLOYEES</li><li>• EXECUTIVE BRANCH CODE OF ETHICS</li><li>• PROJECT WAGE RATES LOCALITY 2 / FEDERAL</li><li>• PROJECT WAGE RATES LOCALITY 3 / FEDERAL</li><li>• NOTICE OF REQUIREMENT FOR AFFIRMATIVE ACTION TO ENSURE EEO NELSON</li><li>• NOTICE OF REQUIREMENT FOR AFFIRMATIVE ACTION TO ENSURE EEO TAYLOR</li><li>• NOTICE OF REQUIREMENT FOR AFFIRMATIVE ACTION TO ENSURE EEO WASHINGTON</li></ul>
PART IV	INSURANCE
PART V	BID ITEMS

**PART I**  
**SCOPE OF WORK**

## ADMINISTRATIVE DISTRICT - 04

**CONTRACT ID - 194205**

**121GR19T005-HSIP**

**COUNTY - NELSON**

**PCN - 0409002451901**

**HSIP 9010 (361)**

NEW SHEPHERDSVILLE ROAD (KY 245) (MP 4.96) IMPROVEMENTS AT THE INTERSECTION OF KY 245 & KY 1430 (MP 5.34), A DISTANCE OF 0.38 MILES.SIGNS-LIGHTING-SIGNALS SYP NO. 04-09006.50.

GEOGRAPHIC COORDINATES LATITUDE 37:50:20.40 LONGITUDE 85:29:21.60

**COUNTY - TAYLOR**

**PCN - 0410900681901**

**HSIP 9010 (362)**

EAST BROADWAY (US 68) (MP 5.867) IMPROVEMENTS AT THE INTERSECTION OF US 68 & KY 289 (MP 5.977), A DISTANCE OF 0.11 MILES.SIGNS-LIGHTING-SIGNALS SYP NO. 04-09006.60.

GEOGRAPHIC COORDINATES LATITUDE 37:20:35.70 LONGITUDE 85:20:31.70

**COUNTY - WASHINGTON**

**PCN - 0411505551901**

**HSIP 9010 (359)**

TRIPLE FIVE HIGHWAY (KY 555) (MP 1.180) IMPROVEMENTS AT THE INTERSECTION OF KY 555 & US 150 (MP 1.660), A DISTANCE OF 0.48 MILES.SIGNS-LIGHTING-SIGNALS SYP NO. 04-09006.20.

GEOGRAPHIC COORDINATES LATITUDE 37:42:08.90 LONGITUDE 85:12:43.60

**PCN - 0411505551902**

**HSIP 9010 (360)**

TRIPLE FIVE HIGHWAY (KY 555) (MP .7) IMPROVEMENTS AT THE INTERSECTION OF KY 555 & KY 528 (MP .98), A DISTANCE OF 0.28 MILES.SIGNS-LIGHTING-SIGNALS SYP NO. 04-09006.30.

GEOGRAPHIC COORDINATES LATITUDE 37:41:53.30 LONGITUDE 85:13:18.00

**COMPLETION DATE(S):**

COMPLETED BY 10/31/2019

APPLIES TO ENTIRE CONTRACT

## **CONTRACT NOTES**

### **PROPOSAL ADDENDA**

All addenda to this proposal must be applied when calculating bid and certified in the bid packet submitted to the Kentucky Department of Highways. Failure to use the correct and most recent addenda may result in the bid being rejected.

### **BID SUBMITTAL**

Bidder must use the Department's electronic bidding software. The Bidder must download the bid file located on the Bid Express website ([www.bidx.com](http://www.bidx.com)) to prepare a bid packet for submission to the Department. The bidder must submit electronically using Bid Express.

### **JOINT VENTURE BIDDING**

Joint venture bidding is permissible. All companies in the joint venture must be prequalified in one of the work types in the Qualifications for Bidders for the project. The bidders must get a vendor ID for the joint venture from the Division of Construction Procurement and register the joint venture as a bidder on the project. Also, the joint venture must obtain a digital ID from Bid Express to submit a bid. A joint bid bond of 5% may be submitted for both companies or each company may submit a separate bond of 5%.

### **UNDERGROUND FACILITY DAMAGE PROTECTION**

The contractor shall make every effort to protect underground facilities from damage as prescribed in the Underground Facility Damage Protection Act of 1994, Kentucky Revised Statute KRS 367.4901 to 367.4917. It is the contractor's responsibility to determine and take steps necessary to be in compliance with federal and state damage prevention directives. When prescribed in said directives, the contractor shall submit Excavation Locate Requests to the Kentucky Contact Center (KY811) via web ticket entry. The submission of this request does not relieve the contractor from the responsibility of contacting non-member facility owners, whom shall be contacted through their individual Protection Notification Center. Non-compliance with these directives can result in the enforcement of penalties.

### **REGISTRATION WITH THE SECRETARY OF STATE BY A FOREIGN ENTITY**

Pursuant to KRS 176.085(1)(b), an agency, department, office, or political subdivision of the Commonwealth of Kentucky shall not award a state contract to a person that is a foreign entity required by [KRS 14A.9-010](#) to obtain a certificate of authority to transact business in the Commonwealth ("certificate") from the Secretary of State under [KRS 14A.9-030](#) unless the person produces the certificate within fourteen (14) days of the bid or proposal opening. If the foreign entity is not required to obtain a certificate as provided in [KRS 14A.9-010](#), the foreign entity should identify the applicable exception. Foreign entity is defined within [KRS 14A.1-070](#).

**For all foreign entities required to obtain a certificate of authority to transact business in the Commonwealth, if a copy of the certificate is not received by the contracting agency within the time frame identified above, the foreign entity's solicitation response shall be deemed non-responsive or the awarded contract shall be cancelled.**

Businesses can register with the Secretary of State at <https://secure.kentucky.gov/sos/ftbr/welcome.aspx>.

### **SPECIAL NOTE FOR PROJECT QUESTIONS DURING ADVERTISEMENT**

Questions about projects during the advertisement should be submitted in writing to the Division of Construction Procurement. This may be done by fax (502) 564-7299 or email to [kytc.projectquestions@ky.gov](mailto:kytc.projectquestions@ky.gov). The Department will attempt to answer all submitted questions. The Department reserves the right not to answer if the question is not pertinent or does not aid in clarifying the project intent.

The deadline for posting answers will be 3:00 pm Eastern Daylight Time, the day preceding the Letting. Questions may be submitted until this deadline with the understanding that the later a question is submitted, the less likely an answer will be able to be provided.

The questions and answers will be posted for each Letting under the heading "Questions & Answers" on the Construction Procurement website ([www.transportation.ky.gov/contract](http://www.transportation.ky.gov/contract)). The answers provided shall be considered part of this Special Note and, in case of a discrepancy, will govern over all other bidding documents.

### **HARDWOOD REMOVAL RESTRICTIONS**

The US Department of Agriculture has imposed a quarantine in Kentucky and several surrounding states, to prevent the spread of an invasive insect, the emerald ash borer. Hardwood cut in conjunction with the project may not be removed from the state. Chipping or burning on site is the preferred method of disposal.

### **INSTRUCTIONS FOR EXCESS MATERIAL SITES AND BORROW SITES**

Identification of excess material sites and borrow sites shall be the responsibility of the Contractor. The Contractor shall be responsible for compliance with all applicable state and federal laws and may wish to consult with the US Fish and Wildlife Service to seek protection under Section 10 of the Endangered Species Act for these activities.

### **ACCESS TO RECORDS**

The contractor, as defined in KRS 45A.030 (9) agrees that the contracting agency, the Finance and Administration Cabinet, the Auditor of Public Accounts, and the Legislative Research Commission, or their duly authorized representatives, shall have access to any books, documents, papers, records, or other evidence, which are directly pertinent to this contract for the purpose of financial audit or program review. Records and other prequalification information confidentially

disclosed as part of the bid process shall not be deemed as directly pertinent to the contract and shall be exempt from disclosure as provided in KRS 61.878(1)(c). The contractor also recognizes that any books, documents, papers, records, or other evidence, received during a financial audit or program review shall be subject to the Kentucky Open Records Act, KRS 61.870 to 61.884.

In the event of a dispute between the contractor and the contracting agency, Attorney General, or the Auditor of Public Accounts over documents that are eligible for production and review, the Finance and Administration Cabinet shall review the dispute and issue a determination, in accordance with Secretary's Order 11-004.

April 30, 2018

### **FEDERAL CONTRACT NOTES**

The Kentucky Department of Highways, in accordance with the Regulations of the United States Department of Transportation 23 CFR 635.112 (h), hereby notifies all bidders that failure by a bidder to comply with all applicable sections of the current Kentucky Standard Specifications, including, but not limited to the following, may result in a bid not being considered responsive and thus not eligible to be considered for award:

102.02 Current Capacity Rating 102.10 Delivery of Proposals  
102.8 Irregular Proposals 102.14 Disqualification of Bidders  
102.9 Proposal Guaranty

### **CIVIL RIGHTS ACT OF 1964**

The Kentucky Department of Highways, in accordance with the provisions of Title VI of the Civil Rights Act of 1964 (78 Stat. 252) and the Regulations of the Federal Department of Transportation (49 C.F.R., Part 21), issued pursuant to such Act, hereby notifies all bidders that it will affirmatively insure that the contract entered into pursuant to this advertisement will be awarded to the lowest responsible bidder without discrimination on the ground of race, color, or national origin.

### **NOTICE TO ALL BIDDERS**

To report bid rigging activities call: 1-800-424-9071.

The U.S. Department of Transportation (DOT) operates the above toll-free "hotline" Monday through Friday, 8:00 a.m. to 5:00 p.m. eastern time. Anyone with knowledge of possible bid rigging, bidder collusion, or other fraudulent activities should use the "hotline" to report such activities.

The "hotline" is part of the DOT's continuing effort to identify and investigate highway construction contract fraud and abuse and is operated under the direction of the DOT Inspector General. All information will be treated confidentially and caller anonymity will be respected.

### **SECOND TIER SUBCONTRACTS**

Second Tier subcontracts on federally assisted projects shall be permitted. However, in the case of DBE's, second tier subcontracts will only be permitted where the other subcontractor is also a DBE. All second tier subcontracts shall have the consent of both the Contractor and the Engineer.



### **DISADVANTAGED BUSINESS ENTERPRISE PROGRAM**

It is the policy of the Kentucky Transportation Cabinet (“the Cabinet”) that Disadvantaged Business Enterprises (“DBE”) shall have the opportunity to participate in the performance of highway construction projects financed in whole or in part by Federal Funds in order to create a level playing field for all businesses who wish to contract with the Cabinet. To that end, the Cabinet will comply with the regulations found in 49 CFR Part 26, and the definitions and requirements contained therein shall be adopted as if set out verbatim herein.

The Cabinet, contractors, subcontractors, and sub-recipients shall not discriminate on the basis of race, color, national origin, or sex in the performance of work performed pursuant to Cabinet contracts. The contractor shall carry out applicable requirements of 49 CFR 26 in the award and administration of federally assisted highway construction projects. The contractor will include this provision in all its subcontracts and supply agreements pertaining to contracts with the Cabinet.

Failure by the contractor to carry out these requirements is a material breach of its contract with the Cabinet, which may result in the termination of the contract or such other remedy as the Cabinet deems necessary.

### **DBE GOAL**

The Disadvantaged Business Enterprise (DBE) goal established for this contract, as listed on the front page of the proposal, is the percentage of the total value of the contract.

The contractor shall exercise all necessary and reasonable steps to ensure that Disadvantaged Business Enterprises participate in a least the percent of the contract as set forth above as goals for this contract.

### **OBLIGATION OF CONTRACTORS**

Each contractor prequalified to perform work on Cabinet projects shall designate and make known to the Cabinet a liaison officer who is assigned the responsibility of effectively administering and promoting an active program for utilization of DBEs.

If a formal goal has not been designated for the contract, all contractors are encouraged to consider DBEs for subcontract work as well as for the supply of material and services needed to perform this work.

Contractors are encouraged to use the services of banks owned and controlled by minorities and women.

### **CERTIFICATION OF CONTRACT GOAL**

Contractors shall include the following certification in bids for projects for which a DBE goal has been established. BIDS SUBMITTED WHICH DO NOT INCLUDE CERTIFICATION OF DBE PARTICIPATION WILL NOT BE ACCEPTED. These bids will not be considered for award by the Cabinet and they will be returned to the bidder.

“The bidder certifies that it has secured participation by Disadvantaged Business Enterprises (“DBE”) in the amount of \_\_\_\_ percent of the total value of this contract and that the DBE participation is in compliance with the requirements of 49 CFR 26 and the policies of the Kentucky Transportation Cabinet pertaining to the DBE Program.”

**The certification statement is located in the electronic bid file. All contractors must certify their DBE participation on that page. DBEs utilized in achieving the DBE goal must be certified and prequalified for the work items at the time the bid is submitted.**

### **DBE PARTICIPATION PLAN**

Lowest responsive bidders must submit the *DBE Plan/ Subcontractor Request*, form TC 14-35 DBE, within **5** days of the letting. This is necessary before the Awards Committee will review and make a recommendation. **The project will not be considered for award prior to submission and approval of the apparent low bidder’s DBE Plan/Subcontractor Request.**

The DBE Participation Plan shall include the following:

- 1 Name and address of DBE Subcontractor(s) and/or supplier(s) intended to be used in the proposed project;
- 2 Description of the work each is to perform including the work item , unit, quantity, unit price and total amount of the work to be performed by the individual DBE. The Project Code Number (PCN), Category Number, and the Project Line Number can be found in the “material listing” on the Construction Procurement website under the specific letting;
- 3 The dollar value of each proposed DBE subcontract and the percentage of total project contract value this represents. DBE participation may be counted as follows; a) If DBE suppliers and manufactures assume actual and contractual responsibility, the dollar value of materials to be furnished will be counted toward the goal as follows:
  - The entire expenditure paid to a DBE manufacturer;
  - 60 percent of expenditures to DBE suppliers that are not manufacturers provided the supplier is a regular dealer in the product involved. A regular dealer must be engaged in, as its principal business and in its own name, the sale of products to the public, maintain an inventory and own and operate distribution equipment; and
  - The amount of fees or commissions charged by the DBE firms for a bona fide service, such as professional, technical, consultant, or managerial services and assistance in the procurement of essential personnel, facilities, equipment, materials, supplies, delivery of materials and supplies or for furnishing bonds, or insurance, providing such fees or commissions are determined to be reasonable and customary.

- b) The dollar value of services provided by DBEs such as quality control testing, equipment repair and maintenance, engineering, staking, etc.;
  - c) The dollar value of joint ventures. DBE credit for joint ventures will be limited to the dollar amount of the work actually performed by the DBE in the joint venture;
- 4 Written and signed documentation of the bidder's commitment to use a DBE contractor whose participation is being utilized to meet the DBE goal; and
- 5 Written and signed confirmation from the DBE that it is participating in the contract as provided in the prime contractor's commitment.

#### **UPON AWARD AND BEFORE A WORK ORDER WILL BE ISSUED**

Contractors must submit the signed subcontract between the contractor and the DBE contractor, the DBE's certificate of insurance, and an affidavit for bidders, offerors, and contractors from the DBE to the Division of Construction Procurement. The affidavit can be found on the Construction Procurement website. If the DBE is a supplier of materials for the project, a signed purchase order and an affidavit for bidders, offerors, and contractors must be submitted to the Division of Construction Procurement.

Changes to DBE Participation Plans must be approved by the Cabinet. The Cabinet may consider extenuating circumstances including, but not limited to, changes in the nature or scope of the project, the inability or unwillingness of a DBE to perform the work in accordance with the bid, and/or other circumstances beyond the control of the prime contractor.

#### **CONSIDERATION OF GOOD FAITH EFFORTS REQUESTS**

If the DBE participation submitted in the bid by the apparent lowest responsive bidder does not meet or exceed the DBE contract goal, the apparent lowest responsive bidder must submit a Good Faith Effort Package to satisfy the Cabinet that sufficient good faith efforts were made to meet the contract goals prior to submission of the bid. Efforts to increase the goal after bid submission will not be considered in justifying the good faith effort, unless the contractor can show that the proposed DBE was solicited prior to the letting date. DBEs utilized in achieving the DBE goal must be certified and prequalified for the work items at the time the bid is submitted. One complete set and nine (9) copies of this information must be received in the office of the Division of Contract Procurement no later than 12:00 noon of the tenth calendar day after receipt of notification that they are the apparent low bidder.

Where the information submitted includes repetitious solicitation letters it will be acceptable to submit a sample representative letter along with a distribution list of the firms solicited. Documentation of DBE quotations shall be a part of the good faith effort submittal as necessary to demonstrate compliance with the factors listed below which the Cabinet considers in judging good faith efforts. This documentation may include written subcontractors' quotations, telephone log notations of verbal quotations, or other types of quotation documentation.

The Good Faith Effort Package shall include, but may not be limited to information showing evidence of the following:

- 1 Whether the bidder attended any pre-bid meetings that were scheduled by the Cabinet to inform DBEs of subcontracting opportunities;
- 2 Whether the bidder provided solicitations through all reasonable and available means;
- 3 Whether the bidder provided written notice to all DBEs listed in the DBE directory at the time of the letting who are prequalified in the areas of work that the bidder will be subcontracting;
- 4 Whether the bidder followed up initial solicitations of interest by contacting DBEs to determine with certainty whether they were interested. If a reasonable amount of DBEs within the targeted districts do not provide an intent to quote or no DBEs are prequalified in the subcontracted areas, the bidder must notify the DBE Liaison in the Office of Minority Affairs to give notification of the bidder's inability to get DBE quotes;
- 5 Whether the bidder selected portions of the work to be performed by DBEs in order to increase the likelihood of meeting the contract goals. This includes, where appropriate, breaking out contract work items into economically feasible units to facilitate DBE participation, even when the prime contractor might otherwise perform these work items with its own forces;
- 6 Whether the bidder provided interested DBEs with adequate and timely information about the plans, specifications, and requirements of the contract;
- 7 Whether the bidder negotiated in good faith with interested DBEs not rejecting them as unqualified without sound reasons based on a thorough investigation of their capabilities. Any rejection should be so noted in writing with a description as to why an agreement could not be reached;
- 8 Whether quotations were received from interested DBE firms but were rejected as unacceptable without sound reasons why the quotations were considered unacceptable. The fact that the DBE firm's quotation for the work is not the lowest quotation received will not in itself be considered as a sound reason for rejecting the quotation as unacceptable. The fact that the bidder has the ability and/or desire to perform the contract work with its own forces will not be considered a sound reason for rejecting a DBE quote. Nothing in this provision shall be construed to require the bidder to accept unreasonable quotes in order to satisfy DBE goals;
- 9 Whether the bidder specifically negotiated with subcontractors to assume part of the responsibility to meet the contract DBE goal when the work to be subcontracted includes potential DBE participation;
- 10 Whether the bidder made any efforts and/or offered assistance to interested DBEs in obtaining the necessary equipment, supplies, materials, insurance and/or bonding to satisfy the work requirements of the bid proposal; and
- 11 Any other evidence that the bidder submits which may show that the bidder has made reasonable good faith efforts to include DBE participation.

### **FAILURE TO MEET GOOD FAITH REQUIREMENT**

Where the apparent lowest responsive bidder fails to submit sufficient participation by DBE firms to meet the contract goal and upon a determination by the Good Faith Committee based upon the information submitted that the apparent lowest responsive bidder failed to make sufficient reasonable efforts to meet the contract goal, the bidder will be offered the opportunity to meet in person for administrative reconsideration. The bidder will be notified of the Committee's decision within 24 hours of its decision. The bidder will have 24 hours to request reconsideration of the Committee's decision. The reconsideration meeting will be held within two days of the receipt of a request by the bidder for reconsideration.

The request for reconsideration will be heard by the Office of the Secretary. The bidder will have the opportunity to present written documentation or argument concerning the issue of whether it met the goal or made an adequate good faith effort. The bidder will receive a written decision on the reconsideration explaining the basis for the finding that the bidder did or did not meet the goal or made adequate Good Faith efforts to do so.

The result of the reconsideration process is not administratively appealable to the Cabinet or to the United States Department of Transportation.

The Cabinet reserves the right to award the contract to the next lowest responsive bidder or to rebid the contract in the event that the contract is not awarded to the low bidder as the result of a failure to meet the good faith requirement.

### **SANCTIONS FOR FAILURE TO MEET DBE REQUIREMENTS OF THE PROJECT**

Failure by the prime contractor to fulfill the DBE requirements of a project under contract or to demonstrate good faith efforts to meet the goal constitutes a breach of contract. When this occurs, the Cabinet will hold the prime contractor accountable, as would be the case with all other contract provisions. Therefore, the contractor's failure to carry out the DBE contract requirements shall constitute a breach of contract and as such the Cabinet reserves the right to exercise all administrative remedies at its disposal including, but not limited to the following:

- Disallow credit toward the DBE goal;
- Withholding progress payments;
- Withholding payment to the prime in an amount equal to the unmet portion of the contract goal; and/or
- Termination of the contract.

### **PROMPT PAYMENT**

The prime contractor will be required to pay the DBE within seven (7) working days after he or she has received payment from the Kentucky Transportation Cabinet for work performed or materials furnished.

### **CONTRACTOR REPORTING**

All contractors must keep detailed records and provide reports to the Cabinet on their progress in meeting the DBE requirement on any highway contract. These records may include, but shall not be limited to payroll, lease agreements, cancelled payroll checks, executed subcontracting agreements, etc. Prime contractors will be required to complete and submit a signed and notarized affidavit (TC 18-7) and copies of checks for any monies paid to each DBE subcontractor or supplier utilized to meet a DBE goal. **These documents must be submitted within 10 days of being paid by the Cabinet.**

Payment information that needs to be reported includes date the payment is sent to the DBE, check number, Contract ID, amount of payment and the check date. Before Final Payment is made on this contract, the Prime Contractor will certify that all payments were made to the DBE subcontractor and/or DBE suppliers.

The Prime Contractor should supply the payment information at the time the DBE is compensated for their work. Form to use is located at:

<http://transportation.ky.gov/Construction/Pages/Subcontracts.aspx>

**The prime contractor should notify the KYTC Office of Civil Rights and Small Business Development seven (7) days prior to DBE contractors commencing work on the project. The contact is Melvin Byne and the telephone number is (502) 564-3601.**

Photocopied payments and completed, signed and notarized affidavit must be submitted by the Prime Contractor to: Office of Civil Rights and Small Business Development  
6<sup>th</sup> Floor West 200 Mero Street  
Frankfort, KY 40622

### **DEFAULT OR DECERTIFICATION OF THE DBE**

If the DBE subcontractor or supplier is decertified or defaults in the performance of its work, and the overall goal cannot be credited for the uncompleted work, the prime contractor may utilize a substitute DBE or elect to fulfill the DBE goal with another DBE on a different work item. If after exerting good faith effort in accordance with the Cabinet's Good Faith Effort policies and procedures, the prime contractor is unable to replace the DBE, then the unmet portion of the goal may be waived at the discretion of the Cabinet.

1/27/2017

**LEGAL REQUIREMENTS AND RESPONSIBILITY TO THE PUBLIC – CARGO PREFERENCE ACT (CPA).**

**(REV 12-17-15) (1-16)**

SECTION 7 is expanded by the following new Article:

102.10 **Cargo Preference Act – Use of United States-flag vessels.**

Pursuant to Title 46CFR Part 381, the Contractor agrees

- To utilize privately owned United States-flag commercial vessels to ship at least 50 percent of the gross tonnage (computed separately for dry bulk carriers, dry cargo liners, and tankers) involved, whenever shipping any equipment, material, or commodities pursuant to this contract, to the extent such vessels are available at fair and reasonable rates for United States-flag commercial vessels.

- To furnish within 20 days following the date of loading for shipments originating within the United States or within 30 working days following the date of loading for shipments originating outside the United States, a legible copy of a rated, 'on-board' commercial ocean bill-of-lading in English for each shipment of cargo described in paragraph 1 of this section to both the Contracting Officer (through the prime contractor in the case of subcontractor bills-of-lading) and to the Division of National Cargo, Office of Market Development, Maritime Administration, Washington, DC 20590.

- To insert the substance of the provisions of this clause in all subcontracts issued pursuant to this contract.

## **SPECIAL PROVISION FOR WASTE AND BORROW SITES**

Obtain U.S. Army Corps of Engineer's approval before utilizing a waste or borrow site that involves "Waters of the United States". The Corps of Engineers defines "Waters of the United States" as perennial or intermittent streams, ponds or wetlands. The Corps of Engineers also considers ephemeral streams, typically dry except during rainfall but having a defined drainage channel, to be jurisdictional waters. Direct questions concerning any potential impacts to "Waters of the United States" to the attention of the appropriate District Office for the Corps of Engineers for a determination prior to disturbance. Be responsible for any fees associated with obtaining approval for waste and borrow sites from the U.S. Army Corps of Engineer or other appropriate regulatory agencies.

1-296 Waste & Borrow Sites  
01/02/2012



## **COORDINATION OF WORK WITH OTHER CONTRACTS**

Be advised, there may be an active project(s) adjacent to or within this project. The Engineer will coordinate the work of the Contractors. See Section 105.06.

1-3193 Coordination Contracts  
01/02/2012

## SPECIAL NOTE FOR SIDEWALK RAMPS & DETECTABLE WARNINGS

---

### GENERAL

Unless otherwise stated in the contract, or as directed by or with prior approval from the Engineer, construct Sidewalk Ramps and Detectable Warnings in accordance with Sections 505 and 720; Supplemental Specifications; Standard Drawings RGX-040-03, RPM-150-08, RPM-152-08, RPM-170-09, and RPM-172-07; current editions, as applicable. In lieu of the Detectable Warnings shown on Standard Drawing RGX-040-03, the Department will also allow the use of any Detectable Warnings listed as Phase XI on the [Kentucky Product Evaluation List](http://www.ktc.uky.edu/kytc/kypel/allevvaluations.php) (<http://www.ktc.uky.edu/kytc/kypel/allevvaluations.php>). For Detectable Warnings as shown on Standard Drawing RGX-040-03, saw cut existing sidewalks, curb and gutter, and pavement, if present, as shown on the detail and reconstruct sidewalk ramps with detectable warnings as directed or approved by the Engineer. For Detectable Warnings from the Kentucky Product Evaluation List, install according to the manufacturer's recommendations. Unless specified otherwise in the Contract, construct sidewalk with 4" nominal minimum required thickness; however, if the existing sidewalk thickness is found to be greater or less than the thickness specified, transition the thickness as directed by the Engineer.

Except as required by the work, do not disturb drainage pipe, catch basins, and other roadway features, appurtenances and installations. Restore any roadway features, appurtenances, and installations damaged by the work in like kind materials and design at no additional cost to the Department. Dispose of all waste off the right of way at sites obtained by the Contractor at no additional cost to the Department (see Special Note for Waste and Borrow).

### MEASUREMENT & PAYMENT

**SIDEWALK RAMPS** – The Department will measure Sidewalk Ramps in accordance with Section 505.04.01 and Standard Drawing RPM-170-09, current editions; however, contrary to Sections 505.04.05 and 505.04.06, the Department will not measure Roadway Excavation or Embankment in Place, but shall be incidental to the Sidewalk. Accept payment at the Contract unit price per square yard as full compensation for all labor, materials, equipment, and incidentals required for removal and disposal of existing sidewalk and curb and gutter, excavation and embankment, construction of the sidewalk ramps, reconstruction of the adjacent curb and/or sidewalk as necessary to install the sidewalk ramps, and restoration of disturbed features in accordance with these notes or as directed by the Engineer.

**DETECTABLE WARNINGS** – The Department will measure Detectable Warnings in accordance with Section 505.04.04 and Standard Drawings RGX-040-03 and RPM-170-09, current editions. The Department will make payment according to Section 505.05.

**HANDRAIL** – The Department will measure and make payment for Handrail in accordance with Section 720.05 and Standard Drawing RPM-172-07, current editions.

## TRAFFIC CONTROL PLAN

---

### TRAFFIC CONTROL GENERAL

Except as provided herein, traffic shall be maintained in accordance with the current editions of the Manual on Uniform Traffic Control Devices (MUTCD), Standard Specifications, and the Standard and Sepia Drawings. Except for the roadway and traffic control bid items listed, all items of work necessary to maintain and control traffic will be paid at the lump sum bid price to “Maintain and Control Traffic”.

Contrary to Section 106.01, traffic control devices used on this project may be new, or used in like new condition, at the beginning of the work and maintained in like new condition until completion of the work. Any temporary traffic control items, devices, materials, and incidentals shall remain the property of the contractor unless otherwise addressed, when no longer needed.

### PROJECT PHASING & CONSTRUCTION PROCEDURES

At locations with three or more lanes, maintain one lane of traffic in each direction at all times during construction. At locations with two lanes, maintain alternating one way traffic during construction. Provide a minimum clear lane width of 12 feet; however, provide for passage of vehicles of up to 16 feet in width. If traffic should be stopped due to construction operations, and a school bus or emergency vehicle on an official run arrives on the scene, make provisions for the passage of the school bus or emergency vehicle as quickly as possible.

No lane closures will be allowed on the following dates:

#### Normal Workday Rush Hours

Monday-Friday 7:00 am – 9:00 am, and 3:00 pm – 6:00 pm, daily

#### Holidays & Special Events

Easter Weekend	Friday, April 19, 2019 – Sunday, April 21, 2019
Memorial Day Weekend	Friday, May 24, 2019 – Monday, May 27, 2019
Independence Day	Thursday, July 4, 2019
Labor Day Weekend	Friday, August 30, 2019 – Monday, September 2, 2019

The Engineer may specify additional days and hours when lane closures will not be allowed.

### LANE CLOSURES

Do not leave lane closures in place during non-working hours or prohibited periods, unless otherwise approved by the Engineer. No long-term lane closures (more than 3 days) will be allowed; therefore, lane closures will not be measured for payment.

Traffic Control Plan  
Page 2 of 3

## **TEMPORARY SIGNS**

Temporary sign posts and splices shall be compliant with NCHRP 350 or MASH. Manufacturer's documentation validating this compliance shall be provided to the Engineer prior to installation. Temporary signs, including any splices, shall be installed according to manufacturer's specifications and installation recommendations. Contrary to section 112.04.02, only long-term temporary signs (temporary signs intended to be continuously in place for more than 3 days) will be measured for payment. Short-term temporary signs (temporary signs intended to be left in place for 3 days or less) will not be measured for payment but will be incidental to Maintain and Control Traffic.

## **ARROW PANELS**

Use arrow panels as shown on the Standard Drawings or as directed by the Engineer. The Department will measure for payment the maximum number of arrow panels in concurrent use at the same time on a single day on all sections of the contract. The Department will measure for payment the maximum number of Changeable Message Signs in concurrent use at the same time on a single day on all sections of the contract. The Department will measure individual Arrow Panels only once for payment, regardless of how many times they are set, reset, removed, and relocated during the duration of the project. The Department will not measure replacements for damaged Arrow Panels or for panels signs the Engineer directs be replaced due to poor condition or readability for payment. Retain possession of the Arrow Panels upon completion of the work.

## **BARRICADES**

The Department will not measure barricades used in lieu of barrels and cones for channelization or delineation, but shall be incidental to Maintain and Control Traffic according to Section 112.04.01.

## **THERMOPLASTIC INTERSECTION MARKINGS**

The locations of thermoplastic markings shown in the proposal are approximate. Prior to placing the thermoplastic markings, layout and mark the locations, and obtain the Engineer's approval of the locations.

## **PAVEMENT MARKINGS**

If there is to be a deviation from the striping plan, the Engineer will furnish the Contractor a striping plan prior to placement of the final pavement markings.

Traffic Control Plan  
Page 3 of 3

### **CHANGEABLE MESSAGE SIGNS**

If deemed necessary by the Engineer, Changeable Message Signs will be provided by the Department.

### **TRAFFIC SIGNAL LOOPS**

Install traffic signal loops according to the Special Note for Traffic Signal Loop Replacement. Prior to installing the traffic signal loops, obtain the Engineer's approval of the locations.

### **TEMPORARY ENTRANCES**

The Engineer will not require the Contractor to provide continuous access to farms, single family, duplex, or triplex residential properties during working hours; however, provide reasonable egress and ingress to each such property when actual operations are not in progress at that location. Limit the time during which a farm or residential entrance is blocked to the minimum length of time required for actual operations, not extended for the Contractor's convenience, and in no case exceeding six (6) hours. Notify all residents twenty-four hours in advance of any driveway or entrance closings and make any accommodations necessary to meet the access needs of disabled residents.

Except as allowed by the Phasing as specified above, maintain direct access to all side streets and roads, schools, churches, commercial properties, and apartments or apartment complexes of four or more units at all times. Access to fire hydrants must also be maintained at all times

The Department will measure asphalt materials required to construct and maintain any temporary entrances which may be necessary to provide temporary access; however, the Department will not measure aggregates, excavation, and/or embankment, but shall be incidental to Maintain and Control Traffic. The Engineer will determine the type of surfacing material, asphalt or aggregate, to be used at each entrance.

## SPECIAL NOTE FOR TRAFFIC SIGNAL LOOP DETECTORS

**1.0 DESCRIPTION.** Be advised that there are existing traffic signal loop detectors within the construction limits of this project. Except as specified herein, perform traffic signal loop replacement in accordance with the Department's Standard/Supplemental Specifications, Special Provisions, Special Notes, and Standard/Sepia Drawings, current editions and as directed by the Engineer. Article references are to the Standard Specifications. Furnish all materials, labor, equipment, and incidentals for replacement of traffic signal loop installation(s) and all other work specified as part of this contract.

**1.1 Pre-bid Requirements.** Each Contractor submitting a bid for this work shall make a thorough inspection of the site prior to submitting his bid and shall thoroughly familiarize himself with existing conditions so that the work can be expeditiously performed after a Contract is awarded. Information provided in the Plans regarding types and quantities of work is not to be taken as an accurate or complete evaluation of the materials and conditions to be encountered during construction. The bidder must make his own determinations as to the conditions encountered.

**2.0 MATERIALS.** Except as specified herein, furnish materials in accordance with Subsection 732.02 and Section 835. Provide for materials to be sampled and tested in accordance with the Department's Sampling Manual. Make materials available for sampling a sufficient time in advance of the use of the materials to allow for the necessary time for testing, unless otherwise specified in this Special Note.

**2.1 Maintain and Control Traffic.** See Traffic Control Plan.

**2.2 Sand.** Furnish natural sand meeting the requirements of Subsection 804.04.01.

**2.3 Seeding.** Furnish Seed Mix Type I.

**2.4 Loop Saw Slot and Fill.** Furnish loop sealant, backer rod, and non-shrink grout according to the Saw Slot Detail.

**2.5 Junction Boxes.** Furnish junction box type B, #57 aggregate, and geotextile filter type IV according to junction box detail.

**2.6 Cable No. 14/1 Pair (Lead-in).** Furnish cable that is specified in Section 835. Cable shall be ran splice free. This shall include splice kits to connect to the loop wire.

**2.7 Conduit.** Furnish and install appropriate conduit from transitions to the roadway, junction boxes and poles. See details below.

**3.0 CONSTRUCTION.** Except as specified herein, install and test Traffic Signal Loop Detectors in accordance with Section 723 and the drawings.

**3.1 Testing.** The Contractor shall test all loops and cable no. 14/1 pair (lead-in) according to Subsection 723.03.17 before and after milling the roadway. The Contractor may have to separate the loop from the lead-in to perform this test. If the loop/lead-in meets the requirement in Section 723 at the controller cabinet, the loop/lead-in shall not be replaced. If existing loops do not meet the requirements in Subsection 723.03.17, the loops shall be replaced. Replacement loops may be installed either before or after the milling process.

## Traffic Signal Loop Detectors Page 2 of 8

The Contractor shall verify that loops (both existing and replacement loops) meet the requirements per Subsection 723.03.17 before the final surface is laid. If loops do not meet conditions of Subsection 723.03.17, the Contractor shall replace them before the resurfacing activities begin. If replacement loops have to be reinstalled, the costs of reinstallation shall be incidental to the milling bid item. The Contractor shall re-splice loops to the lead-in with the proper splice as noted in the spec book.

**3.2 Coordination.** Notify the Engineer in writing, two (2) weeks prior to beginning any work. The Engineer will contact the District Traffic Engineer to coordinate the Department's operations with the Contractor's work.

**3.3 Connection.** The Contractor shall schedule all signal loop installation to ensure the new loops are connected to the lead-in and operational within 5 calendar days of the old loops being damaged and/or disconnected. This requirement includes damage caused by any work activity associated with the project. If the new signal loops are not functioning as intended following 5 calendar days, the Department may assess Liquidated Damages at a rate of \$500 per calendar day per signal location until the loops are operating at pre-construction conditions. All liquidated damages will be applied cumulatively.

**3.4 Maintain and Control Traffic.** See Traffic Control Plan.

**3.5 Milling.** On projects involving milling and texturing of the existing pavement, install loops in the existing pavement before or after performing the milling and texturing. After milling, the remnant contents of the existing saw slot (grout, loop wires, backer rod, and/or loop sealant) may not be flush with the top of the milled portion of the surface. In such cases, clear the saw slot of loose remnant contents and refill the saw slot with natural sand. Obtain the Engineer's approval of the stabilized saw slot prior to resurfacing. The Department will not measure for separate payment clearing and stabilizing the saw slot and shall consider this work incidental to milling.

**3.6 Loop Saw Slot and Fill.** The following is a typical step by step procedure for the installation of a loop.

- 1) Carefully mark the slot to be cut, perpendicular to the flow of traffic and centered in the lane.
- 2) Make each saw-cut 3/8-inch wide and at a depth such that the top of the backer rod is a minimum of 4 inches below the surface of asphalt pavement.
- 3) Drill a 1½ inch core hole at each corner and use a chisel to smooth corners to prevent sharp bends in the wire.
- 4) Clean all foreign and loose matter out of the slots and drilled cores and within 1 foot on all sides of the slots using a high pressure washer.
- 5) Completely dry the slots and drilled cores and within 1 foot on all sides of the slots.
- 6) Measure 9-12 inches from the edge of the paved surface (shoulder break or face of curb) and drill a 1½ inch hole on a 45° angle to the conduit adjacent to the roadway.
- 7) Closely inspect all cuts, cores, and slots for jagged edges or protrusions prior to the placement of the wire. All jagged edges and protrusions shall be ground or re-cut and cleaned again.

Traffic Signal Loop Detectors  
Page 3 of 8

- 8) Place the loop wire splice-free from the termination point (cabinet or junction box) to the loop, continue around the loop for two turns (6'x30' loop) or three turns (6'x6' loop), and return to the termination point.
- 9) Push the wire into the saw slot with a blunt object such as a wooden stick. Make sure that the loop wire is pushed fully to the bottom of the saw slot. Screwdrivers shall not be used.
- 10) Install duct sealant to a minimum of 1 inch deep into the cored 1½ inch hole.
- 11) Apply loop sealant from the bottom up and fully encapsulate the loop wires in the saw slot. The wire should not be able to move when the sealant has set.
- 12) Cover the encapsulated loop wire with a continuous layer of backer rod along the entire loop and home run saw slots such that no voids are present between the loop sealant and backer rod.
- 13) Finish filling the saw cut with non-shrinkable grout per manufacturer's instructions. Alleviate all air pockets and refill low spaces. There shall be no concave portion to the grout in the saw slot. Any excess grout shall be cleaned from the roadway to alleviate tracking.
- 14) Clean up the site and dispose of all waste off the project.
- 15) Ensure that the grout has completely cured prior to subjecting the loop to traffic. Curing time varies with temperature and humidity.

**3.7 Final Dressing, Clean Up, and Seeding.** After all work is completed, clean work sites and all disturbed areas. Dispose of all waste and debris off the right of way at sites obtained by the Contractor at no additional cost to the Department. Sow all disturbed earthen areas with Seed Mix Type I.

**3.8 Removal.** The Contractor shall remove all existing junction boxes, wire from spans/poles/junction boxes/conduits, and conduits. The removal will be incidental to the project.

**3.9 Property/Roadway Damage.** The Contractor shall be responsible for all damage to public and/or private property resulting from the work. Upon completion of the work, restore all disturbed highway features and private property in like kind design and materials at no additional cost to the Department.

**3.10 Right-of-Way Limits.** The Department has not established exact limits of Right-of-Way. Limit work activities to obvious Right-of-Way and work areas secured by the Department through Consent and Release of the adjacent property owners. Contractor is responsible for all encroachments onto private lands.

**3.11 Utility Clearance.** Work around and do not disturb existing utilities. The Department does not anticipate any utility impacts for loop installation. If utilities are impacted, work with associated utility companies to resolve issues.

**3.12 Control.** Obtain the Engineer's approval of all designs required to be furnished by the Contractor prior to incorporation into the work. The Department reserves the right to permit other contractors, state forces, public utility companies, and others to do work during the construction within the limits of, or adjacent to, the project. Conduct operations and cooperate with such other parties so that interference with each other's work will be reduced to a minimum. The Contractor agrees to make no claims against the Department for additional compensation due to delays or other conditions created by



## Traffic Signal Loop Detectors

Page 4 of 8

the operations of such other parties. Should a difference of opinion arise as to the rights of the Contractor and others working within the limits of, or adjacent to, the project, the Engineer will decide as to the respective rights of the various parties involved in order to ensure the completion of the work in general harmony and in a satisfactory manner, and the Engineer's decision shall be final and binding upon the Contractor.

**3.13 Bore and Jack.** Except for situations outlined in 3.15, bore and jack will be used if conduit is under pavement of any kind. The conduit shall be 2" rigid steel conduit under all pavement areas except for the area where the loop transitions from the saw slot. The installation of conduit should follow the below detail.

**3.14 Open Cut Roadway.** With permission of the Engineer, roadway may be open cut if the conduit is under pavement. The conduit shall be 2" rigid steel conduit under all pavement areas except for the area that the loop transition from the saw slot. The installation of conduit should follow requirements per Section 723.

**4.0 MEASUREMENT.** See Subsection 723.04 for bid item notes. Additional bid items include the following:

**4.1 Loop Test.** The Department will measure the quantity as each individual unit loop tested. The Department will not measure disconnection, reconnection, traffic control, re-splicing per specifications, before and after testing per note above, and any associated hardware for payment and will consider them incidental to this item of work.

**5.0 PAYMENT.** The Department will make payment for the completed and accepted quantities of listed items according to Subsection 723.05 in addition to the following:

<u>Code</u>	<u>Pay Item</u>	<u>Pay Unit</u>
Conduit 1"	4792	Linear Foot
PVC Conduit – 1 ¼ inch – sch 80	24900EC	Linear Foot
PVC Conduit – 2 inch – sch 80	24901EC	Linear Foot
Conduit 2"	4795	Linear Foot
Electrical Junction Box type B	4811	Each
Loop Test	24963ED	Each
Trenching and Backfilling	4820	Linear Foot
Loop Wire	4830	Linear Foot
Cable-No. 14/1 Pair	4850	Linear Foot <sup>1</sup>
Loop Saw Slot and Fill	4895	Linear Foot <sup>1</sup>
Bore and Jack Conduit	21543EN	Linear Foot <sup>3</sup>
Open Cut Roadway	4821	Linear Foot <sup>3</sup>

The Department will consider payment as full compensation for all work required under these notes and the Standard Specifications.

# Traffic Signal Loop Detectors

Page 5 of 8

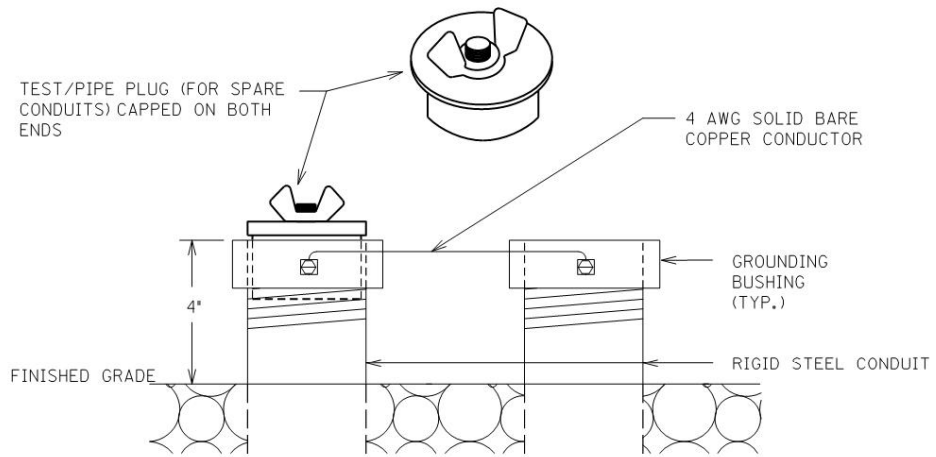

TEST/PIPE PLUG(FOR SPARE CONDUITS) AND GROUNDING DETAIL

# Traffic Signal Loop Detectors

## Page 6 of 8

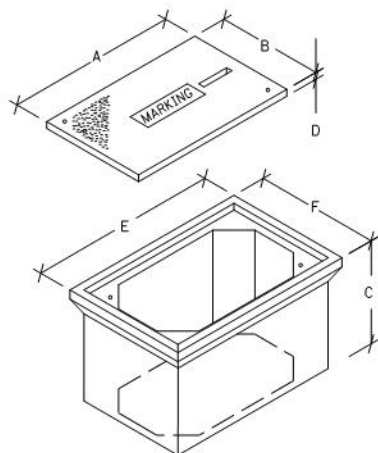

JUNCTION BOX DIMENSIONS (NOMINAL)						
	A	B	C	D	E	F
TYPE A	23"	14"	27"	2"	25"	15"
TYPE B	18"	11"	12"	1 3/4"	20"	13"
TYPE C	36"	24"	30"	3"	38"	26"

• MINIMUM  
NOTE: STACKABLE BOXES ARE PERMITTED

BEFORE THE INSTALLATION OF THE #57 AGGREGATE AND JUNCTION BOX, THE CONTRACTOR SHALL INSTALL GEOTEXTILE FILTER FABRIC TYPE IV IN THE HOLE. THE FABRIC SHALL EXTEND TO JUST BELOW THE LIP OF THE JUNCTION BOX AND SHALL BE CONTINUOUSLY ADHERED TO THE EXTERIOR OF THE BOX WITH ADHESIVE. ANY LOCATIONS WHERE CONDUITS ENTER THE BOX, THE FABRIC SHALL BE 'X CUT' ONLY AS MUCH AS NECESSARY TO ALLOW PASSAGE OF EACH INDIVIDUAL CONDUIT THROUGH THE FABRIC. THE FABRIC SHALL BE INCIDENTAL TO BID ITEMS 481I, 2039INS835, OR 20392NS835.

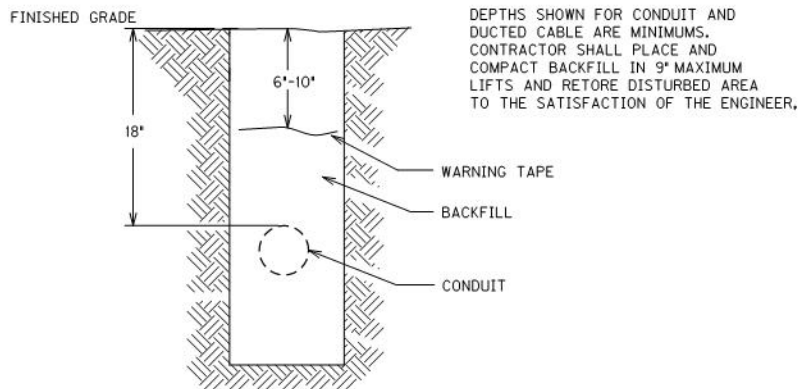
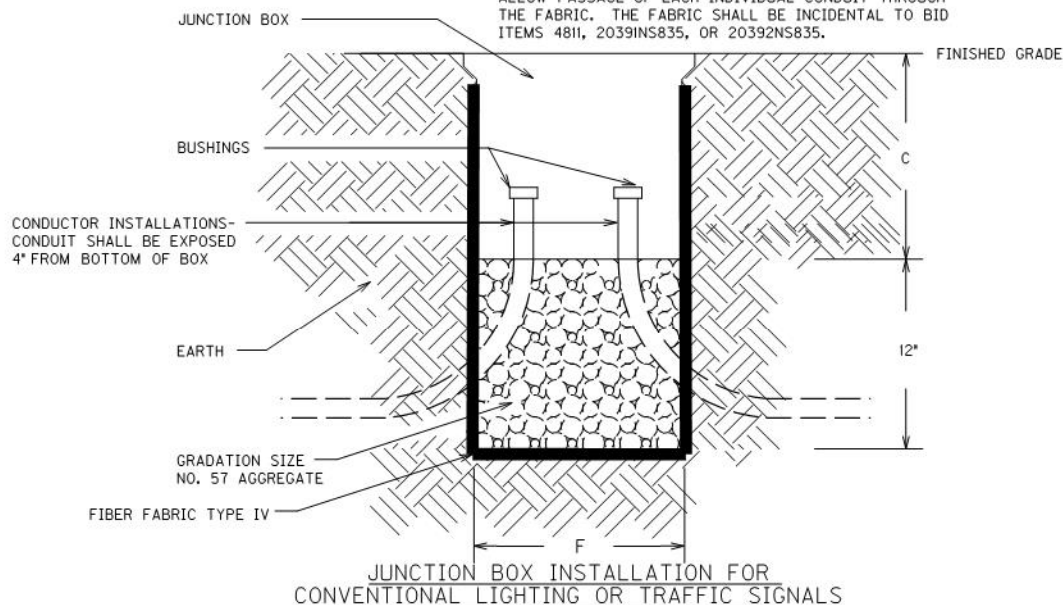

### Traffic Signal Loop Detectors Page 7 of 8

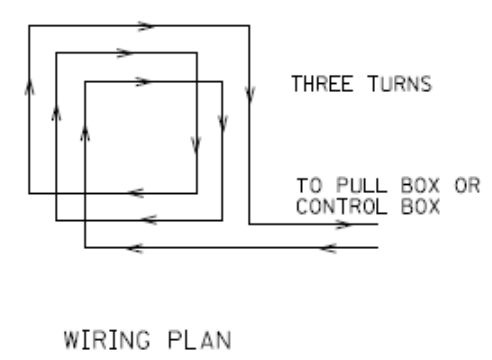
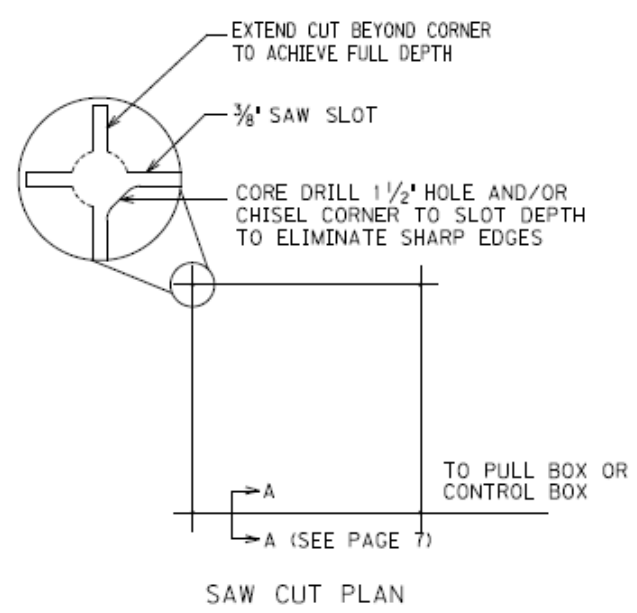

6'X6' LOOP

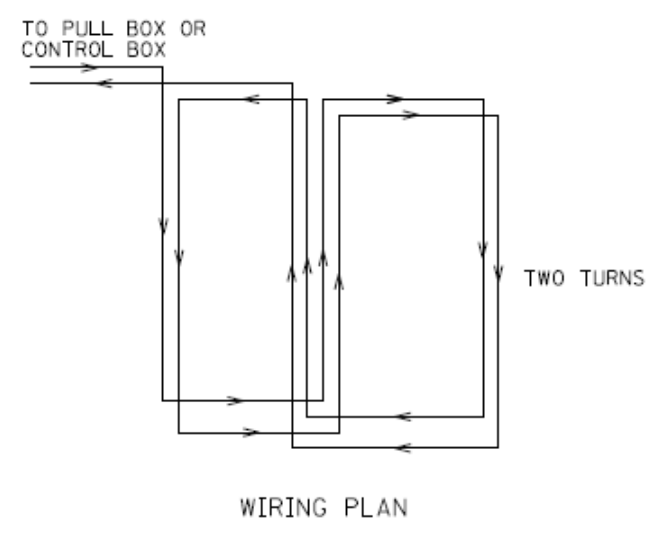
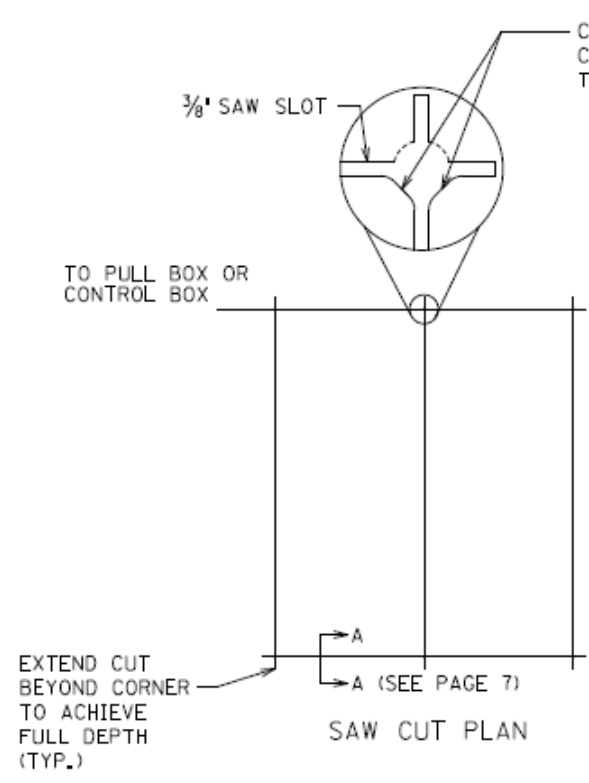

6'X30' QUADRAPOLE LOOP

# Traffic Signal Loop Detectors

Page 8 of 8

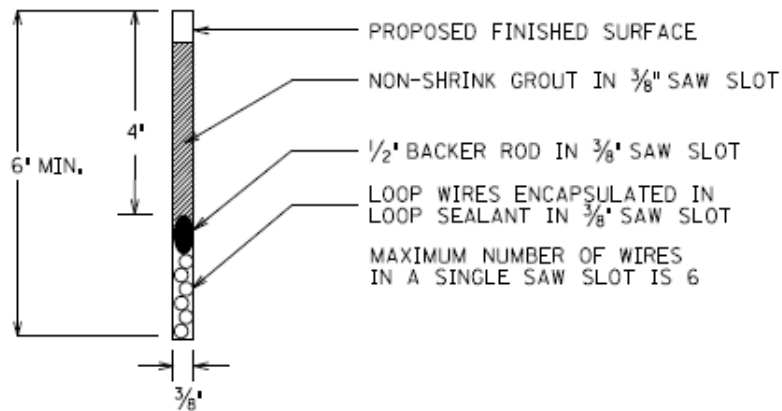

SECTION A-A (SAW SLOT DETAIL)

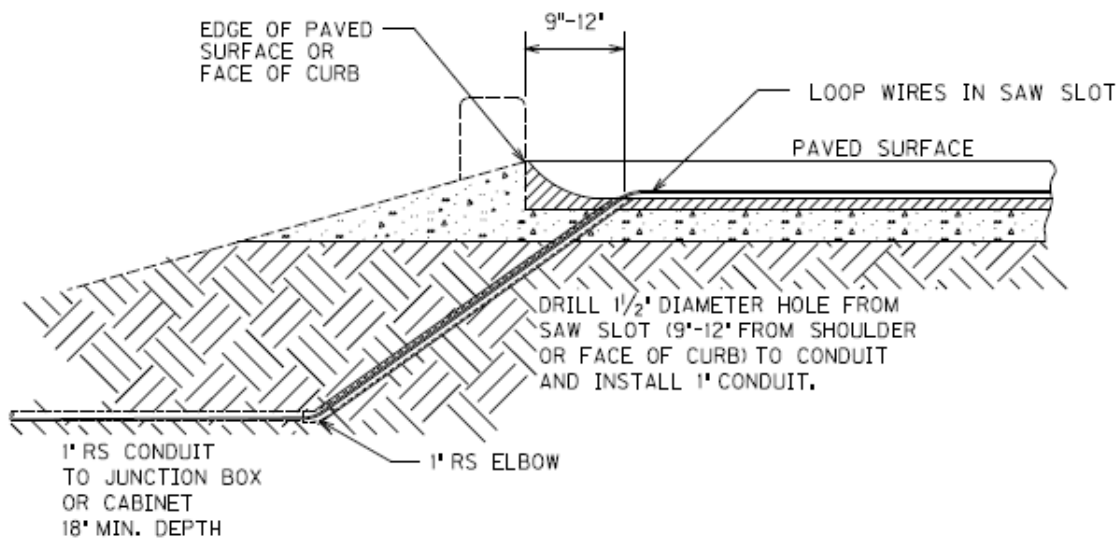

SAW SLOT EDGE OF PAVEMENT TRANSITION

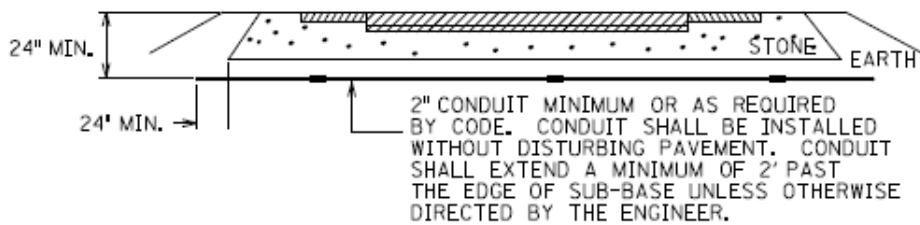

CONDUIT UNDER EXISTING PAVEMENT DETAIL

	<b>KENTUCKY TRANSPORTATION CABINET</b> Department of Highways <b>DIVISION OF RIGHT OF WAY &amp; UTILITIES</b>	TC 62-226 Rev. 01/2016 Page 1 of 1
<b>RIGHT OF WAY CERTIFICATION</b>		

<input checked="" type="checkbox"/>	Original	<input type="checkbox"/>	Re-Certification	<b>RIGHT OF WAY CERTIFICATION</b>		
<b>ITEM #</b>	<b>COUNTY</b>	<b>PROJECT # (STATE)</b>	<b>PROJECT # (FEDERAL)</b>			
4-9006.20	Washington	FD52 115 0555 001-002	HSIP 9010 288			
<b>PROJECT DESCRIPTION</b>						
Install dual red signal heads and reflective tape for backplates, relocate stop bars and restripe edgeline tapers at the US 150/KY 555 intersection.						
<input checked="" type="checkbox"/>	<b>No Additional Right of Way Required</b>					
Construction will be within the limits of the existing right of way. The right of way was acquired in accordance to FHWA regulations under the Uniform Relocation Assistance and Real Property Acquisitions Policy Act of 1970, as amended. No additional right of way or relocation assistance were required for this project.						
<input type="checkbox"/>	<b>Condition # 1 (Additional Right of Way Required and Cleared)</b>					
All necessary right of way, including control of access rights when applicable, have been acquired including legal and physical possession. Trial or appeal of cases may be pending in court but legal possession has been obtained. There may be some improvements remaining on the right-of-way, but all occupants have vacated the lands and improvements, and KYTC has physical possession and the rights to remove, salvage, or demolish all improvements and enter on all land. Just Compensation has been paid or deposited with the court. All relocations have been relocated to decent, safe, and sanitary housing or that KYTC has made available to displaced persons adequate replacement housing in accordance with the provisions of the current FHWA directive.						
<input type="checkbox"/>	<b>Condition # 2 (Additional Right of Way Required with Exception)</b>					
The right of way has not been fully acquired, the right to occupy and to use all rights-of-way required for the proper execution of the project has been acquired. Some parcels may be pending in court and on other parcels full legal possession has not been obtained, but right of entry has been obtained, the occupants of all lands and improvements have vacated, and KYTC has physical possession and right to remove, salvage, or demolish all improvements. Just Compensation has been paid or deposited with the court for most parcels. Just Compensation for all pending parcels will be paid or deposited with the court prior to AWARD of construction contract						
<input type="checkbox"/>	<b>Condition # 3 (Additional Right of Way Required with Exception)</b>					
The acquisition or right of occupancy and use of a few remaining parcels are not complete and/or some parcels still have occupants. All remaining occupants have had replacement housing made available to them in accordance with 49 CFR 24.204. KYTC is hereby requesting authorization to advertise this project for bids and to proceed with bid letting even though the necessary right of way will not be fully acquired, and/or some occupants will not be relocated, and/or the just compensation will not be paid or deposited with the court for some parcels until after bid letting. KYTC will fully meet all the requirements outlined in 23 CFR 635.309(c)(3) and 49 CFR 24.102(j) and will expedite completion of all acquisitions, relocations, and full payments after bid letting and prior to AWARD of the construction contract or force account construction.						
Total Number of Parcels on Project	EXCEPTION (S) Parcel #	ANTICIPATED DATE OF POSSESSION WITH EXPLANATION				
Number of Parcels That Have Been Acquired						
Signed Deed						
Condemnation						
Signed ROE						
Notes/ Comments (Use Additional Sheet if necessary)						
<b>LPA RW Project Manager</b>				<b>Right of Way Supervisor</b>		
Printed Name	Charles A. Allen			Printed Name	Michael H. Price	
Signature	<i>Charles A. Allen</i>			Signature	<i>Michael H. Price</i>	
Date	10/18/2018			Date	10/22/2018	
<b>Asst. Right of Way Director</b>				FHWA		
Printed Name	Kelly R. Divine			Printed Name	No Signature Required as per FHWA-KYTC	
Signature	<i>Kelly R. Divine</i>			Signature	Current Stewardship Agreement	
Date	10/22/18			Date		

	KENTUCKY TRANSPORTATION CABINET Department of Highways DIVISION OF RIGHT OF WAY & UTILITIES  <b>RIGHT OF WAY CERTIFICATION</b>	TC 62-226 Rev. 01/2016 Page 1 of 1
---	--	--

<input checked="" type="checkbox"/>	Original	<input type="checkbox"/>	Re-Certification	<b>RIGHT OF WAY CERTIFICATION</b>		
ITEM #	COUNTY	PROJECT # (STATE)	PROJECT # (FEDERAL)			
4-9006.30	Washington	FD52 115 0555 000-001	HSIP 9010 288			
<b>PROJECT DESCRIPTION</b>						
Add green extension loop detectors, install supplemental heads and add backplates with reflective tape at the KY 555/KY 528 intersection.						
<input checked="" type="checkbox"/>	<b>No Additional Right of Way Required</b>					
Construction will be within the limits of the existing right of way. The right of way was acquired in accordance to FHWA regulations under the Uniform Relocation Assistance and Real Property Acquisitions Policy Act of 1970, as amended. No additional right of way or relocation assistance were required for this project.						
<input type="checkbox"/>	<b>Condition # 1 (Additional Right of Way Required and Cleared)</b>					
All necessary right of way, including control of access rights when applicable, have been acquired including legal and physical possession. Trial or appeal of cases may be pending in court but legal possession has been obtained. There may be some improvements remaining on the right-of-way, but all occupants have vacated the lands and improvements, and KYTC has physical possession and the rights to remove, salvage, or demolish all improvements and enter on all land. Just Compensation has been paid or deposited with the court. All relocations have been relocated to decent, safe, and sanitary housing or that KYTC has made available to displaced persons adequate replacement housing in accordance with the provisions of the current FHWA directive.						
<input type="checkbox"/>	<b>Condition # 2 (Additional Right of Way Required with Exception)</b>					
The right of way has not been fully acquired, the right to occupy and to use all rights-of-way required for the proper execution of the project has been acquired. Some parcels may be pending in court and on other parcels full legal possession has not been obtained, but right of entry has been obtained, the occupants of all lands and improvements have vacated, and KYTC has physical possession and right to remove, salvage, or demolish all improvements. Just Compensation has been paid or deposited with the court for most parcels. Just Compensation for all pending parcels will be paid or deposited with the court prior to AWARD of construction contract						
<input type="checkbox"/>	<b>Condition # 3 (Additional Right of Way Required with Exception)</b>					
The acquisition or right of occupancy and use of a few remaining parcels are not complete and/or some parcels still have occupants. All remaining occupants have had replacement housing made available to them in accordance with 49 CFR 24.204. KYTC is hereby requesting authorization to advertise this project for bids and to proceed with bid letting even though the necessary right of way will not be fully acquired, and/or some occupants will not be relocated, and/or the just compensation will not be paid or deposited with the court for some parcels until after bid letting. KYTC will fully meet all the requirements outlined in 23 CFR 635.309(c)(3) and 49 CFR 24.102(j) and will expedite completion of all acquisitions, relocations, and full payments after bid letting and prior to AWARD of the construction contract or force account construction.						
Total Number of Parcels on Project		EXCEPTION (S) Parcel #		ANTICIPATED DATE OF POSSESSION WITH EXPLANATION		
Number of Parcels That Have Been Acquired						
Signed Deed						
Condemnation						
Signed ROE						
Notes/ Comments (Use Additional Sheet if necessary)						
<b>LPA RW Project Manager</b>				<b>Right of Way Supervisor</b>		
Printed Name	Charles A. Allen			Printed Name	Michael H. Price	
Signature	<i>Charles A. Allen</i>			Signature	<i>Michael H. Price</i>	
Date	10/18/2018			Date	10/22/2018	
<b>Asst. Right of Way Director</b>				<b>FHWA</b>		
Printed Name	Kelly R. Divine			Printed Name		
Signature	<i>Kelly R. Divine</i>			Signature	No Signature Required as per FHWA-KYTC Current Stewardship Agreement	
Date	10/22/18			Date		

	<b>KENTUCKY TRANSPORTATION CABINET</b> Department of Highways <b>DIVISION OF RIGHT OF WAY &amp; UTILITIES</b>	TC 62-226 Rev. 01/2016 Page 1 of 1
<b>RIGHT OF WAY CERTIFICATION</b>		

<input checked="" type="checkbox"/> Original		<input type="checkbox"/> Re-Certification		<b>RIGHT OF WAY CERTIFICATION</b>			
<b>ITEM #</b>		<b>COUNTY</b>		<b>PROJECT # (STATE)</b>		<b>PROJECT # (FEDERAL)</b>	
4-9006.50		Nelson		FD52 090 0245 005-006		HSIP 9010 288	
<b>PROJECT DESCRIPTION</b>							
Install overhead advance warning system and upgrade the signal by installing dual red heads with backplates at the intersection of KY 245 and KY 1430.							
<input checked="" type="checkbox"/> <b>No Additional Right of Way Required</b>							
Construction will be within the limits of the existing right of way. The right of way was acquired in accordance to FHWA regulations under the Uniform Relocation Assistance and Real Property Acquisitions Policy Act of 1970, as amended. No additional right of way or relocation assistance were required for this project.							
<input type="checkbox"/> <b>Condition # 1 (Additional Right of Way Required and Cleared)</b>							
All necessary right of way, including control of access rights when applicable, have been acquired including legal and physical possession. Trial or appeal of cases may be pending in court but legal possession has been obtained. There may be some improvements remaining on the right-of-way, but all occupants have vacated the lands and improvements, and KYTC has physical possession and the rights to remove, salvage, or demolish all improvements and enter on all land. Just Compensation has been paid or deposited with the court. All relocations have been relocated to decent, safe, and sanitary housing or that KYTC has made available to displaced persons adequate replacement housing in accordance with the provisions of the current FHWA directive.							
<input type="checkbox"/> <b>Condition # 2 (Additional Right of Way Required with Exception)</b>							
The right of way has not been fully acquired, the right to occupy and to use all rights-of-way required for the proper execution of the project has been acquired. Some parcels may be pending in court and on other parcels full legal possession has not been obtained, but right of entry has been obtained, the occupants of all lands and improvements have vacated, and KYTC has physical possession and right to remove, salvage, or demolish all improvements. Just Compensation has been paid or deposited with the court for most parcels. Just Compensation for all pending parcels will be paid or deposited with the court prior to AWARD of construction contract							
<input type="checkbox"/> <b>Condition # 3 (Additional Right of Way Required with Exception)</b>							
The acquisition or right of occupancy and use of a few remaining parcels are not complete and/or some parcels still have occupants. All remaining occupants have had replacement housing made available to them in accordance with 49 CFR 24.204. KYTC is hereby requesting authorization to advertise this project for bids and to proceed with bid letting even though the necessary right of way will not be fully acquired, and/or some occupants will not be relocated, and/or the just compensation will not be paid or deposited with the court for some parcels until after bid letting. KYTC will fully meet all the requirements outlined in 23 CFR 635.309(c)(3) and 49 CFR 24.102(j) and will expedite completion of all acquisitions, relocations, and full payments after bid letting and prior to AWARD of the construction contract or force account construction.							
Total Number of Parcels on Project		EXCEPTION (S) Parcel #		ANTICIPATED DATE OF POSSESSION WITH EXPLANATION			
Number of Parcels That Have Been Acquired							
Signed Deed							
Condemnation							
Signed ROE							
Notes/ Comments (Use Additional Sheet if necessary)							
<b>LPA RW Project Manager</b>				<b>Right of Way Supervisor</b>			
Printed Name	Charles A. Allen			Printed Name	Michael H. Price		
Signature	<i>Charles A. Allen</i>			Signature	<i>Michael H. Price</i>		
Date	10/18/2018			Date	10/22/2018		
<b>Asst. Right of Way Director</b>				<b>FHWA</b>			
Printed Name	Kelly R. Divine			Printed Name	Signature Required		
Signature	<i>Kelly R. Divine</i>			Signature	of FHWA-KYTC		
Date	10/22/18			Date	of Stewardship Agreement		



	<b>KENTUCKY TRANSPORTATION CABINET</b> Department of Highways <b>DIVISION OF RIGHT OF WAY &amp; UTILITIES</b>	TC 62-226 Rev. 01/2016 Page 1 of 1
<b>RIGHT OF WAY CERTIFICATION</b>		

<input checked="" type="checkbox"/> Original	<input type="checkbox"/> Re-Certification	<b>RIGHT OF WAY CERTIFICATION</b>	
<b>ITEM #</b>	<b>COUNTY</b>	<b>PROJECT # (STATE)</b>	<b>PROJECT # (FEDERAL)</b>
4-9006.60	Taylor	FD52 109 0068 005-006	HSIP 9010 288

**PROJECT DESCRIPTION**  
 Install green loop extensions, add reflective backplates to the signals and install signs prohibiting right-turn-on-red at the intersection of US 68 and KY 289.

**No Additional Right of Way Required**  
 Construction will be within the limits of the existing right of way. The right of way was acquired in accordance to FHWA regulations under the Uniform Relocation Assistance and Real Property Acquisitions Policy Act of 1970, as amended. No additional right of way or relocation assistance were required for this project.

**Condition # 1 (Additional Right of Way Required and Cleared)**  
 All necessary right of way, including control of access rights when applicable, have been acquired including legal and physical possession. Trial or appeal of cases may be pending in court but legal possession has been obtained. There may be some improvements remaining on the right-of-way, but all occupants have vacated the lands and improvements, and KYTC has physical possession and the rights to remove, salvage, or demolish all improvements and enter on all land. Just Compensation has been paid or deposited with the court. All relocations have been relocated to decent, safe, and sanitary housing or that KYTC has made available to displaced persons adequate replacement housing in accordance with the provisions of the current FHWA directive.

**Condition # 2 (Additional Right of Way Required with Exception)**  
 The right of way has not been fully acquired, the right to occupy and to use all rights-of-way required for the proper execution of the project has been acquired. Some parcels may be pending in court and on other parcels full legal possession has not been obtained, but right of entry has been obtained, the occupants of all lands and improvements have vacated, and KYTC has physical possession and right to remove, salvage, or demolish all improvements. Just Compensation has been paid or deposited with the court for most parcels. Just Compensation for all pending parcels will be paid or deposited with the court prior to AWARD of construction contract

**Condition # 3 (Additional Right of Way Required with Exception)**  
 The acquisition or right of occupancy and use of a few remaining parcels are not complete and/or some parcels still have occupants. All remaining occupants have had replacement housing made available to them in accordance with 49 CFR 24.204. KYTC is hereby requesting authorization to advertise this project for bids and to proceed with bid letting even though the necessary right of way will not be fully acquired, and/or some occupants will not be relocated, and/or the just compensation will not be paid or deposited with the court for some parcels until after bid letting. KYTC will fully meet all the requirements outlined in 23 CFR 635.309(c)(3) and 49 CFR 24.102(j) and will expedite completion of all acquisitions, relocations, and full payments after bid letting and prior to AWARD of the construction contract or force account construction.

Total Number of Parcels on Project	EXCEPTION (S) Parcel #	ANTICIPATED DATE OF POSSESSION WITH EXPLANATION
Number of Parcels That Have Been Acquired		
Signed Deed		
Condemnation		
Signed ROE		

Notes/ Comments (Use Additional Sheet if necessary)

<b>LPA RW Project Manager</b>		<b>Right of Way Supervisor</b>	
Printed Name	Charles A. Allen	Printed Name	Michael H. Price
Signature	<i>Charles A. Allen</i>	Signature	<i>Michael H. Price</i>
Date	10/18/2018	Date	10/22/2018
<b>Asst. Right of Way Director</b>		<b>FHWA</b>	
Printed Name	Kelly R. Divine	Printed Name	No Signature Required
Signature	<i>Kelly R. Divine</i>	Signature	as per FHWA-KYTC
Date	10/22/18	Date	Current Stewardship Agreement

## UTILITIES AND RAIL CERTIFICATION NOTE

Washington, Nelson, and Taylor Counties

Item 4-9006.20 - FD52 115 0555 001-002 - Install reflective backplates and update the striping at the Intersection of KY 555 & US 150

Item 4-9006.30 - FD52 115 0555 000-001 - Install reflective backplates, supplemental signal heads, and green extension loop detectors at the Intersection of KY 555 & KY 528

Item 4-9006.50 - FD52 090 0245 004-006 - Install overhead advance warning flashers and upgrade the signal by installing dual red heads and reflective backplates at the intersection of KY 245 & KY 1430

Item 4-9006.60 - FD52 109 0068 005-006 - Install green extension loop detectors, update the signal by installing reflective backplates, and signing upgrades at the Intersection of US 68 & KY 289

### GENERAL PROJECT NOTE ON UTILITY PROTECTION

It is the opinion of the Cabinet that no utility relocations and/or adjustments will be required for the completion of the subject projects.

### NOTE: DO NOT DISTURB THE FOLLOWING UTILITIES LOCATED WITHIN THE PROJECT DISTURB LIMITS

N/A

### THE FOLLOWING COMPANIES ARE RELOCATING/ADJUSTING THEIR UTILITIES WITHIN THE PROJECT LIMITS AND WILL BE COMPLETE PRIOR TO CONSTRUCTION

N/A

### THE FOLLOWING COMPANIES HAVE FACILITIES TO BE RELOCATED/ADJUSTED BY THE COMPANY OR THE COMPANY'S SUBCONTRACTOR AND IS TO BE COORDINATED WITH THE ROAD CONTRACT

N/A

### THE FOLLOWING COMPANIES HAVE FACILITIES TO BE RELOCATED/ADJUSTED BY THE ROAD CONTRACTOR AS INCLUDED IN THIS CONTRACT

N/A

### THE FOLLOWING RAIL COMPANIES HAVE FACILITIES IN CONJUNCTION WITH THIS PROJECT AS NOTED

No Rail Involved       Minimal Rail Involved (See Below)       Rail Involved (See Below)

## UTILITIES AND RAIL CERTIFICATION NOTE

Washington, Nelson, and Taylor Counties

- Item 4-9006.20 - FD52 115 0555 001-002 - Install reflective backplates and update the striping at the Intersection of KY 555 & US 150
- Item 4-9006.30 - FD52 115 0555 000-001 - Install reflective backplates, supplemental signal heads, and green extension loop detectors at the Intersection of KY 555 & KY 528
- Item 4-9006.50 - FD52 090 0245 004-006 - Install overhead advance warning flashers and upgrade the signal by installing dual red heads and reflective backplates at the intersection of KY 245 & KY 1430
- Item 4-9006.60 - FD52 109 0068 005-006 - Install green extension loop detectors, update the signal by installing reflective backplates, and signing upgrades at the Intersection of US 68 & KY 289

### **UNDERGROUND FACILITY DAMAGE PROTECTION – BEFORE YOU DIG**

The contractor shall make every effort to protect underground facilities from damage as prescribed in the Underground Facility Damage Protection Act of 1994, Kentucky Revised Statute KRS 367.4901 to 367.4917. It is the contractor's responsibility to determine and take steps necessary to be in compliance with federal and state damage prevention directives. The contractor is instructed to contact KY 811 for the location of existing underground utilities. Contact shall be made a minimum of two (2) and no more than ten (10) business days prior to excavation.

The contractor shall submit Excavation Locate Requests to the Kentucky Contact Center (KY 811) via web ticket entry. The submission of this request does not relieve the contractor from the responsibility of contacting non-member facility owners, whom are to be contacted through their individual Protection Notification Center. It may be necessary for the contractor to contact the County Court Clerk to determine what utility companies have facilities in the area. Non-compliance with these directives can result in the enforcement of penalties.

### **SPECIAL CAUTION NOTE – PROTECTION OF UTILITIES**

The contractor will be responsible for contacting all utility facility owners on the subject project to coordinate his activities. The contractor will coordinate his activities to minimize and, where possible, avoid conflicts with utility facilities. Due to the nature of the work proposed, it is unlikely to conflict with the existing utilities beyond minor facility adjustments. Where conflicts with utility facilities are unavoidable, the contractor will coordinate any necessary relocation work with the facility owner and Resident Engineer. The Kentucky Transportation Cabinet maintains the right to remove or alter portions of this contract if a utility conflict occurs.

The utility facilities as noted in the previous section(s) have been determined using data garnered by varied means and with varying degrees of accuracy: from the facility owners, a result of S.U.E., field inspections, and/or reviews of record drawings. The facilities defined may not be inclusive of all utilities in the project scope and are not Level A quality, unless specified as such. It is the contractor's responsibility to verify all utilities and their respective locations before excavating.

***Please Note: The information presented in this Utility Note is informational in nature and the information contained herein is not guaranteed.***

## UTILITIES AND RAIL CERTIFICATION NOTE

Washington, Nelson, and Taylor Counties	
Item 4-9006.20 - FD52 115 0555 001-002	Install reflective backplates and update the striping at the Intersection of KY 555 & US 150
Item 4-9006.30 - FD52 115 0555 000-001	Install reflective backplates, supplemental signal heads, and green extension loop detectors at the Intersection of KY 555 & KY 528
Item 4-9006.50 - FD52 090 0245 004-006	Install overhead advance warning flashers and upgrade the signal by installing dual red heads and reflective backplates at the intersection of KY 245 & KY 1430
Item 4-9006.60 - FD52 109 0068 005-006	Install green extension loop detectors, update the signal by installing reflective backplates, and signing upgrades at the Intersection of US 68 & KY 289

### AREA UTILITIES CONTACT LIST

<u>Utility Company/Agency</u>	<u>Contact Name</u>	<u>Contact Information</u>
1. CITY OF BARDSTOWN WATER/SEWER	LARRY HAMILTON	502-348-5947
2. AT&T	SCOTT ROCHE	502-348-4528
3. SALT RIVER RECC	DANIEL CARRICO	502-373-7730
4. KENTUCKY UTILITIES	ADAM SMITH	270-465-7721
5. LG&E	MIKE KRESS	502-364-8367
6. BARDSTOWN CABLE	MIKE PILE	502-348-5947
7. NORTH NELSON WATER	COLE CISSELL	502-348-8342
8. SPRINGFIELD WATER AND SEWER	TOMMY OSBORNE	859-336-5454
9. SPECTRUM	MARK HARLOW	859-626-4899
10. ATMOS ENERGY	SILAS BOHLEN	270-685-8020
11. TAYLOR COUNTY RECC	MIKE SKAGGS	270-465-4101
12. WINDSTREAM	DAVID KARNES	270-465-2480
13. COMCAST	STEPHEN GADDIE	270-706-0326
14. CITY OF CAMPBELLSVILLE WATER/SEWER	MILLIE RAMSEY	270-789-3133

***NOTE: The Utilities Contact List is provided as informational only, and may not be a complete list of all Utility Companies with facilities in the project area.***

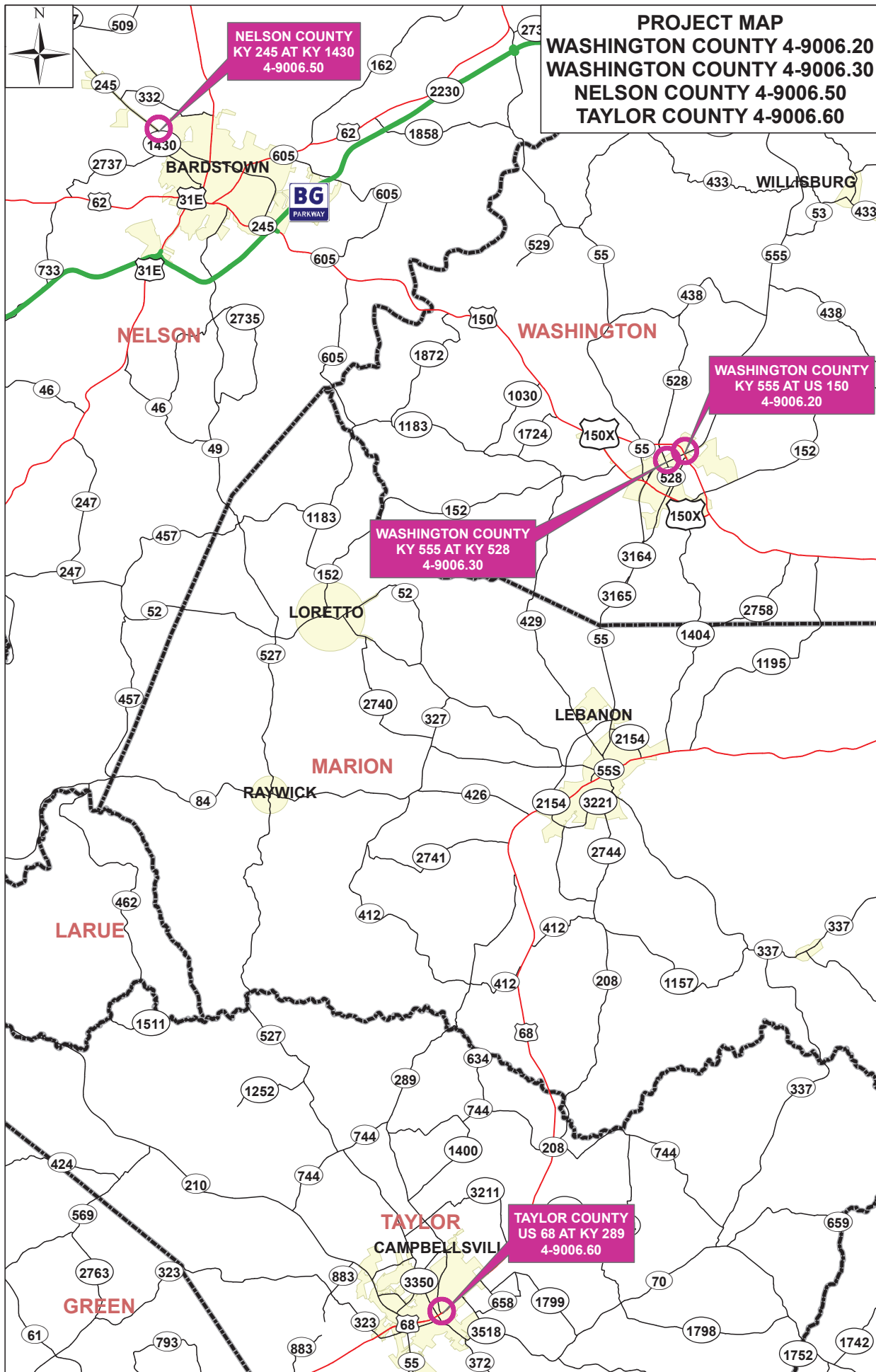

# MATERIAL SUMMARY

**CONTRACT ID: 194205**

**121GR19T005-HSIP**

**0409002451901**

NEW SHEPHERDSVILLE ROAD (KY 245) IMPROVEMENTS AT THE INTERSECTION OF KY 245 & KY 1430  
 SIGNS-LIGHTING-SIGNALS, A DISTANCE OF .38 MILES.

Project Line No	Bid Code	DESCRIPTION	Quantity	Unit
0165	01987	DELINEATOR FOR GUARDRAIL BI DIRECTIONAL WHITE	250.00	EACH
0170	02562	TEMPORARY SIGNS	190.00	SQFT
0175	02650	MAINTAIN & CONTROL TRAFFIC - (NELSON KY 245 @ KY 1430)	1.00	LS
0180	02775	ARROW PANEL	1.00	EACH
0185	06568	PAVE MARKING-THERMO STOP BAR-24IN	120.00	LF
0190	06574	PAVE MARKING-THERMO CURV ARROW	9.00	EACH
0195	04811	ELECTRICAL JUNCTION BOX TYPE B	8.00	EACH
0200	04820	TRENCHING AND BACKFILLING	1,920.00	LF
0205	04844	CABLE-NO. 14/5C	5,452.00	LF
0210	04850	CABLE-NO. 14/1 PAIR	1,850.00	LF
0215	04885	MESSANGER-10800 LB	505.00	LF
0220	04932	INSTALL STEEL STRAIN POLE	4.00	EACH
0225	24955ED	REMOVE SIGNAL EQUIPMENT - (NELSON KY 245 @ KY 1430)	1.00	EACH
0230	20094ES835	TEMP RELOCATION OF SIGNAL HEAD	10.00	EACH
0235	20188NS835	INSTALL LED SIGNAL-3 SECTION	8.00	EACH
0240	20266ES835	INSTALL LED SIGNAL- 4 SECTION	4.00	EACH
0245	20390NS835	INSTALL COORDINATING UNIT	1.00	EACH
0250	20408ES835	INSTALL LED BEACON-12 IN	4.00	EACH
0255	21543EN	BORE AND JACK CONDUIT	50.00	LF
0260	23157EN	TRAFFIC SIGNAL POLE BASE	18.00	CUYD
0265	24901EC	PVC CONDUIT-2 IN-SCHEDULE 80	2,000.00	LF
0270	24908EC	INSTALL SIGNAL CONTROLLER-TY ATC	1.00	EACH
0275	24525EC	ADVANCE WARNING FLASHER	2.00	EACH
0280	02569	DEMOBILIZATION	1.00	LS

# MATERIAL SUMMARY

**CONTRACT ID: 194205**

**121GR19T005-HSIP**

**0410900681901**

EAST BROADWAY (US 68) IMPROVEMENTS AT THE INTERSECTION OF US 68 & KY 289 SIGNS-LIGHTING-SIGNALS, A DISTANCE OF .11 MILES.

Project Line No	Bid Code	DESCRIPTION	Quantity	Unit
0285	02562	TEMPORARY SIGNS	190.00	SQFT
0290	02650	MAINTAIN & CONTROL TRAFFIC - (TAYLOR US 68 @ KY 289)	1.00	LS
0295	02775	ARROW PANEL	1.00	EACH
0300	04960	REMOVE AND REPLACE SIDEWALK	2.00	SQYD
0305	05990	SODDING	80.00	SQYD
0310	23158ES505	DETECTABLE WARNINGS	10.00	SQFT
0315	06566	PAVE MARKING-THERMO X-WALK-12 IN	460.00	LF
0320	06568	PAVE MARKING-THERMO STOP BAR-24IN	120.00	LF
0325	04792	CONDUIT-1 IN	25.00	LF
0330	04811	ELECTRICAL JUNCTION BOX TYPE B	2.00	EACH
0335	04820	TRENCHING AND BACKFILLING	160.00	LF
0340	04830	LOOP WIRE	350.00	LF
0345	04844	CABLE-NO. 14/5C	2,545.00	LF
0350	04850	CABLE-NO. 14/1 PAIR	1,725.00	LF
0355	04884	ANCHOR	2.00	EACH
0360	04886	MESSANGER-15400 LB	175.00	LF
0365	04895	LOOP SAW SLOT AND FILL	115.00	LF
0370	04932	INSTALL STEEL STRAIN POLE	1.00	EACH
0375	24955ED	REMOVE SIGNAL EQUIPMENT - (TAYLOR US 68 @ KY 289)	1.00	EACH
0380	06472	INSTALL SPAN MOUNTED SIGN	1.00	EACH
0385	20093NS835	INSTALL PEDESTRIAN HEAD-LED	2.00	EACH
0390	20094ES835	TEMP RELOCATION OF SIGNAL HEAD	10.00	EACH
0395	21743NN	INSTALL PEDESTRIAN DETECTOR	2.00	EACH
0400	23157EN	TRAFFIC SIGNAL POLE BASE	5.00	CUYD
0405	24900EC	PVC CONDUIT-1 1/4 IN-SCHEDULE 80	165.00	LF
0410	24901EC	PVC CONDUIT-2 IN-SCHEDULE 80	80.00	LF
0415	24908EC	INSTALL SIGNAL CONTROLLER-TY ATC	1.00	EACH
0420	20188NS835	INSTALL LED SIGNAL-3 SECTION	8.00	EACH
0425	20266ES835	INSTALL LED SIGNAL- 4 SECTION	6.00	EACH
0430	02569	DEMOBILIZATION	1.00	LS
0435	06574	PAVE MARKING-THERMO CURV ARROW	9.00	EACH
0440	20390NS835	INSTALL COORDINATING UNIT	1.00	EACH

# MATERIAL SUMMARY

**CONTRACT ID: 194205**

**121GR19T005-HSIP**

**0411505551901**

TRIPLE FIVE HIGHWAY (KY 555) IMPROVEMENTS AT THE INTERSECTION OF KY 555 & US 150 SIGNS-LIGHTING-SIGNALS, A DISTANCE OF .48 MILES.

Project Line No	Bid Code	DESCRIPTION	Quantity	Unit
0005	01987	DELINEATOR FOR GUARDRAIL BI DIRECTIONAL WHITE	690.00	EACH
0010	02562	TEMPORARY SIGNS	190.00	SQFT
0015	02650	MAINTAIN & CONTROL TRAFFIC - (WASHINGTON KY 555 @ US 150)	1.00	LS
0020	02775	ARROW PANEL	1.00	EACH
0025	06514	PAVE STRIPING-PERM PAINT-4 IN	600.00	LF
0030	24683ED	PAVE MARKING-THERMO DOTTED LANE EXTEN	160.00	LF
0035	06546	PAVE STRIPING-THERMO-12 IN W	500.00	LF
0040	06574	PAVE MARKING-THERMO CURV ARROW	10.00	EACH
0045	22520EN	PAVE MARKING-THERMO YIELD BAR-36 IN	48.00	LF
0050	06598	PAVEMENT MARKING REMOVAL	100.00	SQFT
0055	20266ES835	INSTALL LED SIGNAL- 4 SECTION	8.00	EACH
0060	02569	DEMOBILIZATION	1.00	LS
0065	20188NS835	INSTALL LED SIGNAL-3 SECTION	8.00	EACH
0070	24955ED	REMOVE SIGNAL EQUIPMENT - (WASHINGTON KY 555 @ US 150)	1.00	EACH



# MATERIAL SUMMARY

**CONTRACT ID: 194205**

**121GR19T005-HSIP**

**0411505551902**

TRIPLE FIVE HIGHWAY (KY 555) IMPROVEMENTS AT THE INTERSECTION OF KY 555 & KY 528 SIGNS-  
 LIGHTING-SIGNALS, A DISTANCE OF .28 MILES.

Project Line No	Bid Code	DESCRIPTION	Quantity	Unit
0075	01987	DELINEATOR FOR GUARDRAIL BI DIRECTIONAL WHITE	750.00	EACH
0080	02562	TEMPORARY SIGNS	190.00	SQFT
0085	02650	MAINTAIN & CONTROL TRAFFIC - (WASHINGTON KY 555 @ KY 528)	1.00	LS
0090	02775	ARROW PANEL	1.00	EACH
0095	06514	PAVE STRIPING-PERM PAINT-4 IN	600.00	LF
0100	06546	PAVE STRIPING-THERMO-12 IN W	150.00	LF
0105	06568	PAVE MARKING-THERMO STOP BAR-24IN	105.00	LF
0110	06574	PAVE MARKING-THERMO CURV ARROW	4.00	EACH
0115	22520EN	PAVE MARKING-THERMO YIELD BAR-36 IN	12.00	LF
0120	04931	INSTALL CONTROLLER TYPE 170	1.00	EACH
0125	04795	CONDUIT-2 IN	20.00	LF
0130	04797	CONDUIT-3 IN	10.00	LF
0135	04844	CABLE-NO. 14/5C	1,000.00	LF
0140	04850	CABLE-NO. 14/1 PAIR	1,000.00	LF
0145	20188NS835	INSTALL LED SIGNAL-3 SECTION	10.00	EACH
0150	20266ES835	INSTALL LED SIGNAL- 4 SECTION	4.00	EACH
0155	02569	DEMOBILIZATION	1.00	LS
0160	24955ED	REMOVE SIGNAL EQUIPMENT - (WASHINGTON KY 555 @ KY 528)	1.00	EACH

### General Summary - All Intersections

BID CODE	DESCRIPTION	UNIT	QUANTITY
2562	TEMPORARY SIGNS	SQFT	760
2650	MAINTAIN & CONTROL TRAFFIC KY 555 @ US 150	LS	1
2650	MAINTAIN & CONTROL TRAFFIC KY 555 @ KY 528	LS	1
2650	MAINTAIN & CONTROL TRAFFIC KY 245 @ KY 1430	LS	1
2650	MAINTAIN & CONTROL TRAFFIC US 68 @ KY 289	LS	1
2775	ARROW PANEL	EACH	4
1987	DELINEATOR FOR GUARDRAIL B/W	EACH	1690
4960	REMOVE AND REPLACE SIDEWALK	SQYD	2
5990	SODDING	SQYD	80
23158ES505	DETECTABLE WARNINGS	SQFT	10
6514	PAVE STRIPING-PERM PAINT-4 IN	LF	1200
24683ED	PAVE MARKING - THERMO DOTTED LANE EXTEN 6 IN	LF	160
6566	PAVE MARKING-THERMO X-WALK 6 IN	LF	460
6546	PAVE STRIPING-THERMO-12 IN W	LF	650
6568	PAVE MARKING-THERMO STOP BAR-24 IN	LF	345
6574	PAVE MARKING-THERMO CURV ARROW	EACH	32
22520EN	PAVE MARKING-THERMO YIELD BAR-36 IN	LF	60
6598	PAVE MARKING REMOVAL	SF	100
4931	INSTALL CONTROLLER TYPE 170	EACH	1
4795	CONDUIT-2 IN	LF	20
4797	CONDUIT-3 IN	LF	10
4792	CONDUIT 1 INCH	LF	25
4811	ELECTRICAL JUNCTION BOX TYPE B	EACH	10
4820	TRENCHING AND BACKFILLING	LF	2080
4830	LOOP WIRE	LF	350
4844	CABLE-NO. 14/5C	LF	8997
4850	CABLE-NO. 14/1 PAIR	LF	4575
4884	ANCHOR	EACH	2
4885	MESSENGER-10800 LB	LF	505
4886	MESSENGER-15400 LB	LF	175
4895	LOOP SAW SLOT AND FILL	LF	115
4932	INSTALL STEEL STRAIN POLE	EACH	5
24955ED	REMOVE SIGNAL EQUIPMENT	EACH	4
6472	INSTALL SPAN MOUNTED SIGN	EACH	1
20093NS835	INSTALL PEDESTRIAN HEAD LED	EACH	2
20094ES835	TEMPORARY RELOCATION OF SIGNAL HEAD	EACH	20
20390NS835	INSTALL COORDINATING UNIT	EACH	2
20408ES835	INSTALL LED BEACON-12 IN	EACH	4
21543EN	BORE AND JACK CONDUIT	LF	50
21743NN	INSTALL PEDESTRIAN DETECTOR	EACH	2
23157EN	TRAFFIC SIGNAL POLE BASE	CUYD	23
24900EC	PVC CONDUIT - 1 1/4 INCH - SCHEDULE 80	LF	165
24901EC	PVC CONDUIT - 2 INCH - SCHEDULE 80	LF	2080
24908EC	INSTALL SIGNAL CONTROLLER-TY ATC	EACH	2
24525EC	ADVANCE WARNING FLASHER	EACH	2
20188NS835	INSTALL LED SIGNAL-3 SECTION	EACH	34
20266ES835	INSTALL LED SIGNAL-4 SECTION	EACH	22
2569	DEMOBILIZATION	LS	1

Jeff Wolfe - Director

**DIVISION OF TRAFFIC OPERATIONS**

Phone (502) 564-3020  
FAX (502) 564-7759

**RECOMMENDATION FOR PICKUP OF ITEMS TO BE INSTALLED  
ON TRAFFIC SIGNALS/LIGHTING**

Item Number: 4-9006.20  
County: Washington  
Description: KY 555 @ US 150  
(all heads to have reflective backplates)

**Cabinets Master code**

**Signals**

8	T-02-0009	Siemens 3 Section Signal
8	T-02-0032	Siemen 3 section backplate
8	T-02-0034	Siemen 4 section 12" signal double red
8	T-02-0042	4-sec dbl red backplate only
4	T-02-0300	LED Module 12" red arrow
8	T-02-0310	LED Module 12" yellow arrow
20	T-02-0330	LED Module 12" red ball
12	T-02-0340	LED Module 12" yellow ball
12	T-02-0350	LED Module 12" green ball

**Special items**

**Poles**

Electrical Contractor Name \_\_\_\_\_  
Electrical Contractor Supervisor \_\_\_\_\_ Contact number for Supervisor \_\_\_\_\_  
Project Engineer \_\_\_\_\_ Contact number for Project Engineer \_\_\_\_\_

Project Engineer attests that the mentioned contractor is the actual electrical contractor on this project

Signature of Project Engineer or Designee \_\_\_\_\_

<b>Washington Co. KY 555 @ US 150 Summary of Items</b>			
<b>BID CODE</b>	<b>DESCRIPTION</b>	<b>UNIT</b>	<b>QUANTITY</b>
1987	DELINEATOR FOR GUARDRAIL B/W	EACH	690
2562	TEMPORARY SIGNS	SQFT	190
2650	MAINTAIN & CONTROL TRAFFIC KY 555 @ US 150	LS	1
2775	ARROW PANEL	EACH	1
6514	PAVE STRIPING-PERM PAINT-4 IN	LF	600
24683ED	PAVE MARKING - THERMO DOTTED LANE EXTEN 6 INCH	LF	160
6546	PAVE STRIPING-THERMO-12 IN W	LF	500
6574	PAVE MARKING-THERMO CURV ARROW	EACH	10
22520EN	PAVE MARKING-THERMO YIELD BAR-36 IN	LF	48
6598	PAVE MARKING REMOVAL	SF	100
24955ED	REMOVE SIGNAL EQUIPMENT	EACH	1
20188NS835	INSTALL LED SIGNAL-3 SECTION	EACH	8
20266ES835	INSTALL LED SIGNAL-4 SECTION	EACH	8

**Washington County - KY 555 @ US 150  
 Item No. 4-9006.2**

**Signal Head Improvements**

Total of 16 new Signal Heads to be installed with Reflective Backplates.

<b>Signal Head</b>	<b>Red Ball</b>	<b>Yellow Ball</b>	<b>Green Ball</b>	<b>R. Arrow</b>	<b>Y. Arrow</b>	<b>G. Arrow</b>
4 Section Double Red W/Ref. Backplate	2	1	1			
4 Section Double Red W/Ref. Backplate	2	1	1			
4 Section Double Red W/Ref. Backplate	2	1	1			
4 Section Double Red W/Ref. Backplate	2	1	1			
4 Section Double Red W/Ref. Backplate	2	1	1			
4 Section Double Red W/Ref. Backplate	2	1	1			
4 Section Double Red W/Ref. Backplate	2	1	1			
4 Section Double Red W/Ref. Backplate	2	1	1			
3 Sect. Flashing Yellow w/Ref. Backplate				1	2	
3 Sect. Flashing Yellow w/Ref. Backplate				1	2	
3 Sect. Flashing Yellow w/Ref. Backplate				1	2	
3 Sect. Flashing Yellow w/Ref. Backplate				1	2	
3 Section Signal Head w/Ref. backplate	1	1	1			
3 Section Signal Head w/Ref. backplate	1	1	1			
3 Section Signal Head w/Ref. backplate	1	1	1			
3 Section Signal Head w/Ref. backplate	1	1	1			
<b>Totals</b>	<b>20</b>	<b>12</b>	<b>12</b>	<b>4</b>	<b>8</b>	

**Signal Head Notes**

Remove existing thru lane signal heads on the mainline and side street approaches, and install Double Red Heads with Reflective Backplates in their place.  
 Remove existing 3-Section Left Turn Heads on the mainline and side street approaches and install 3 section Flashing Yellow Heads with Ref. Backplates in their place  
 Remove existing 3-Section Supplemental Heads and install 3-Section Heads with Ref. Backplates in their place  
 Contact Traffic Engineer before placing any signal heads to make sure everything is communicated correctly. Jake Riggs - 270 401 8132

US 150 Eastbound



US 150 Westbound



KY 555 Northbound



KY 555 Southbound



### **Striping and Thermo Additions**

Install 160' of Thermo Dotted Lane Line Extensions, 3' bar with a 9' gap, 6" Width

Install 500' 12" Thermo markings around 4 right turn islands.

Install 48' of 24" wide by 36" long Yield Bar Symbols (Sharks Teeth) at each island at the yield point.

Remove Thermo Stop Bar where needed about 100 square feet. Paid as 6598 - Pave Marking Removal.

Install 10 Curve Arrows on Concrete (If needed)

Note - Pavement is not in great shape, depending on resurfacing schedule, Traffic Engineer might remove Thermoplastic from work if new pavement is about to be placed.

Contact Jake Riggs 270 401 8132 prior to any work to have layout approved and to make sure the thermoplastic work is to be completed

There is a paint quantity setup in case the thermo work will be completed by others during resurfacing.

There is a lot of guardrail in the area. Install Bi-Directional Guardrail Delineators.

Contact Jake Riggs for layout.

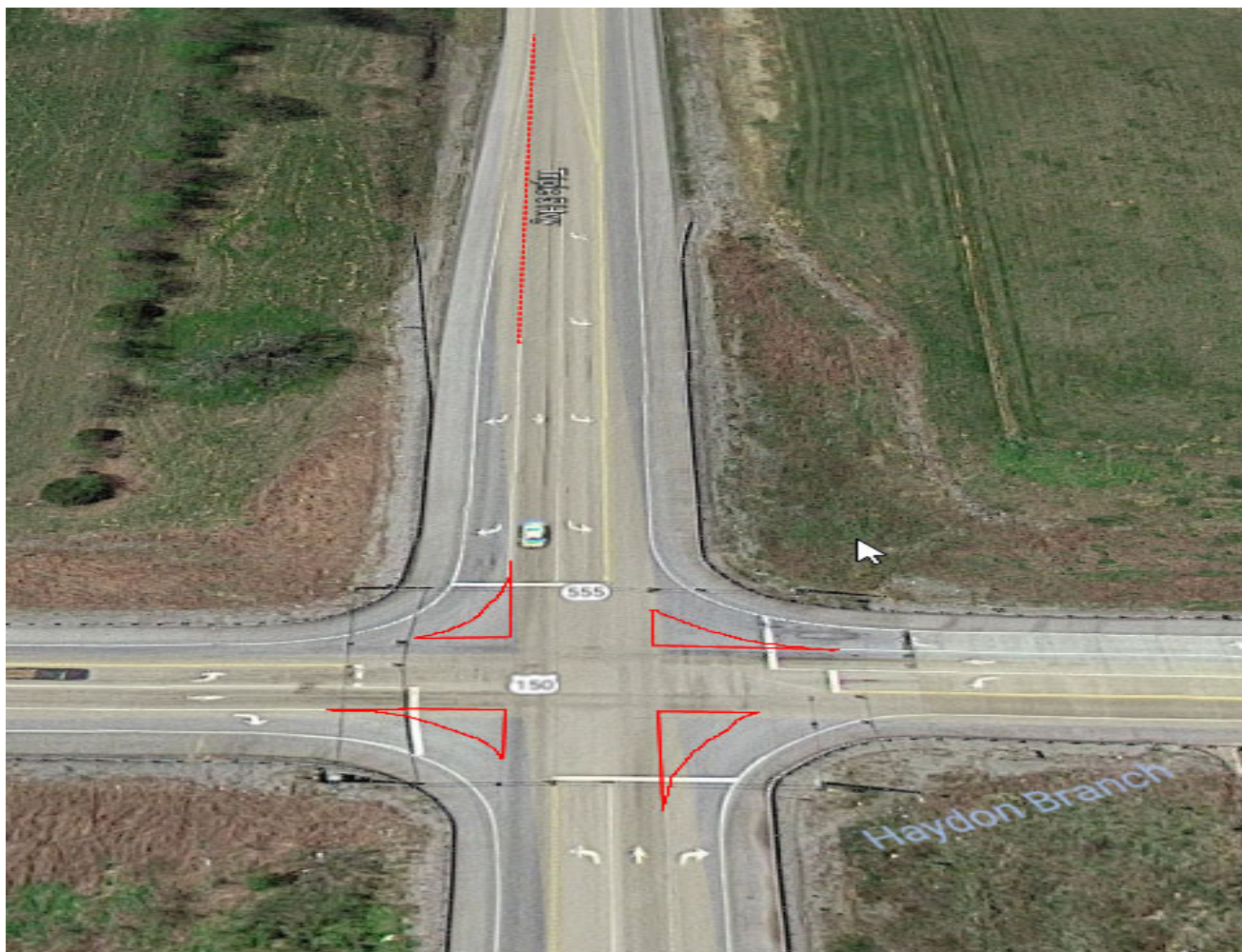

The Department will retain all materials removed from the signal, they can be delivered to the Traffic Barn, located at 310 Valley Creek Road, Elizabethtown, KY 42701

Removal of all equipment is considered incidental to the installation of new poles, heads, cabinets etc.



Jeff Wolfe - Director

**DIVISION OF TRAFFIC OPERATIONS**

Phone (502) 564-3020  
 FAX (502) 564-7759

**RECOMMENDATION FOR PICKUP OF ITEMS TO BE INSTALLED  
 ON TRAFFIC SIGNALS/LIGHTING**

Item Number: 4-9006.30  
 County: Washington  
 Description: KY 555 @ KY 528  
(all heads to have reflective backplates)

Cabinets	Master code	
1	T-01-0020	Base Mounted 332 Cabinet
1	T-01-0100	170 Controller
1	T-01-0501	Conflict Monitor, Model 2018
6	T-01-0600	Loop Detector, Model 222
6	T-01-0700	Load Switches

Signals		
10	T-02-0009	Siemens 3 Section Signal
10	T-02-0032	Siemen 3 section backplate
4	T-02-0034	Siemen 4 section 12" signal double red
4	T-02-0042	4-sec dbl red backplate only
2	T-02-0300	LED Module 12" red arrow
4	T-02-0310	LED Module 12" yellow arrow
16	T-02-0330	LED Module 12" red ball
12	T-02-0340	LED Module 12" yellow ball
12	T-02-0350	LED Module 12" green ball

**Special items**

**Poles**

Electrical Contractor Name \_\_\_\_\_  
 Electrical Contractor Supervisor \_\_\_\_\_ Contact number for Supervisor \_\_\_\_\_  
 Project Engineer \_\_\_\_\_ Contact number for Project Engineer \_\_\_\_\_

Project Engineer attests that the mentioned contractor is the actual electrical contractor on this project

Signature of Project Engineer or Designee \_\_\_\_\_

<b>Washington Co. KY 555 @ KY 528 Summary of Items</b>			
<b>BID CODE</b>	<b>DESCRIPTION</b>	<b>UNIT</b>	<b>QUANTITY</b>
1987	DELINEATOR FOR GUARDRAIL B/W	EACH	750
2562	TEMPORARY SIGNS	SQFT	190
2650	MAINTAIN & CONTROL TRAFFIC KY 555 @ KY 528	LS	1
2775	ARROW PANEL	EACH	1
6514	PAVE STRIPING-PERM PAINT-4 IN	LF	600
6546	PAVE STRIPING-THERMO-12 IN W	LF	150
6568	PAVE MARKING-THERMO STOP BAR-24 IN	LF	105
6574	PAVE MARKING-THERMO CURV ARROW	EACH	4
22520EN	PAVE MARKING-THERMO YIELD BAR-36 IN	LF	12
4931	INSTALL CONTROLLER TYPE 170	EACH	1
4795	CONDUIT-2 IN	LF	20
4797	CONDUIT-3 IN	LF	10
4844	CABLE-NO.14/5C	LF	1000
4850	CABLE-NO. 14/1 PAIR	LF	1000
24955ED	REMOVE SIGNAL EQUIPMENT	EACH	1
20188NS835	INSTALL LED SIGNAL-3 SECTION	EACH	10
20266ES835	INSTALL LED SIGNAL-4 SECTION	EACH	4

**Washington County - KY 555 @ KY 528  
 Item No. 4-9006.3**

**Signal Head Improvements**

Total of 14 new Signal Heads to be installed with Reflective Backplates.

<b>Signal Head</b>	<b>Red Ball</b>	<b>Yellow Ball</b>	<b>Green Ball</b>	<b>R. Arrow</b>	<b>Y. Arrow</b>	<b>G. Arrow</b>
4 Section Double Red W/Ref. Backplate	2	1	1			
4 Section Double Red w/Ref. backplate	2	1	1			
4 Section Double Red w/Ref. backplate	2	1	1			
4 Section Double Red w/Ref. backplate	2	1	1			
3 Sect. Flashing Yellow w/Ref. Backplate				1	2	
3 Sect. Flashing Yellow w/Ref. Backplate				1	2	
3 Section Signal Head w/Ref. backplate	1	1	1			
3 Section Signal Head w/Ref. backplate	1	1	1			
3 Section Signal Head w/Ref. backplate	1	1	1			
3 Section Signal Head w/Ref. backplate	1	1	1			
3 Section Signal Head w/Ref. backplate	1	1	1			
3 Section Signal Head w/Ref. backplate	1	1	1			
3 Section Signal Head w/Ref. backplate	1	1	1			
3 Section Signal Head w/Ref. backplate	1	1	1			
<b>Totals</b>	<b>16</b>	<b>12</b>	<b>12</b>	<b>2</b>	<b>4</b>	

**Signal Head Notes**

Remove existing thru lane signal heads on the mainline and side street approaches, and install Double Red Heads with Reflective Backplates in their place.  
 Remove existing 3-Section Left Turn Heads on the mainline approach and install 3 section Flashing Yellow Heads with Ref. Backplates in their place  
 Remove existing signal heads on the side streets and install 3 Section Heads with Ref. Backplates in their place  
 Install 4 Supplemental Heads, one for every direction, approaching intersection, pole on the right.  
 Contact Traffic Engineer before placing any signal heads to make sure everything is communicated correctly. Jacob Riggs - 270 401 8132

KY 555 Northbound



KY 528 Northbound



KY 528 Southbound



KY 555 Southbound



### **Striping and Thermo Additions**

Install 4 Thermoplastic Arrows on asphalt  
Install 105' of 24" Thermoplastic Stop Bars  
Install 150' of 12" Thermoplastic for Thermo Island  
Install 12' of 24" wide by 36" long Yield Symbols (Sharks Teeth) at each island at the yield point.

As previously stated KY 555 is nearing resurfacing, we might not do any thermoplastic work. There is a paint quantity setup in case the thermo work will be completed by others during resurfacing. Contact Jake Riggs 270 401 8132 prior to any work to have layout approved and to make sure the thermo work is to be completed.

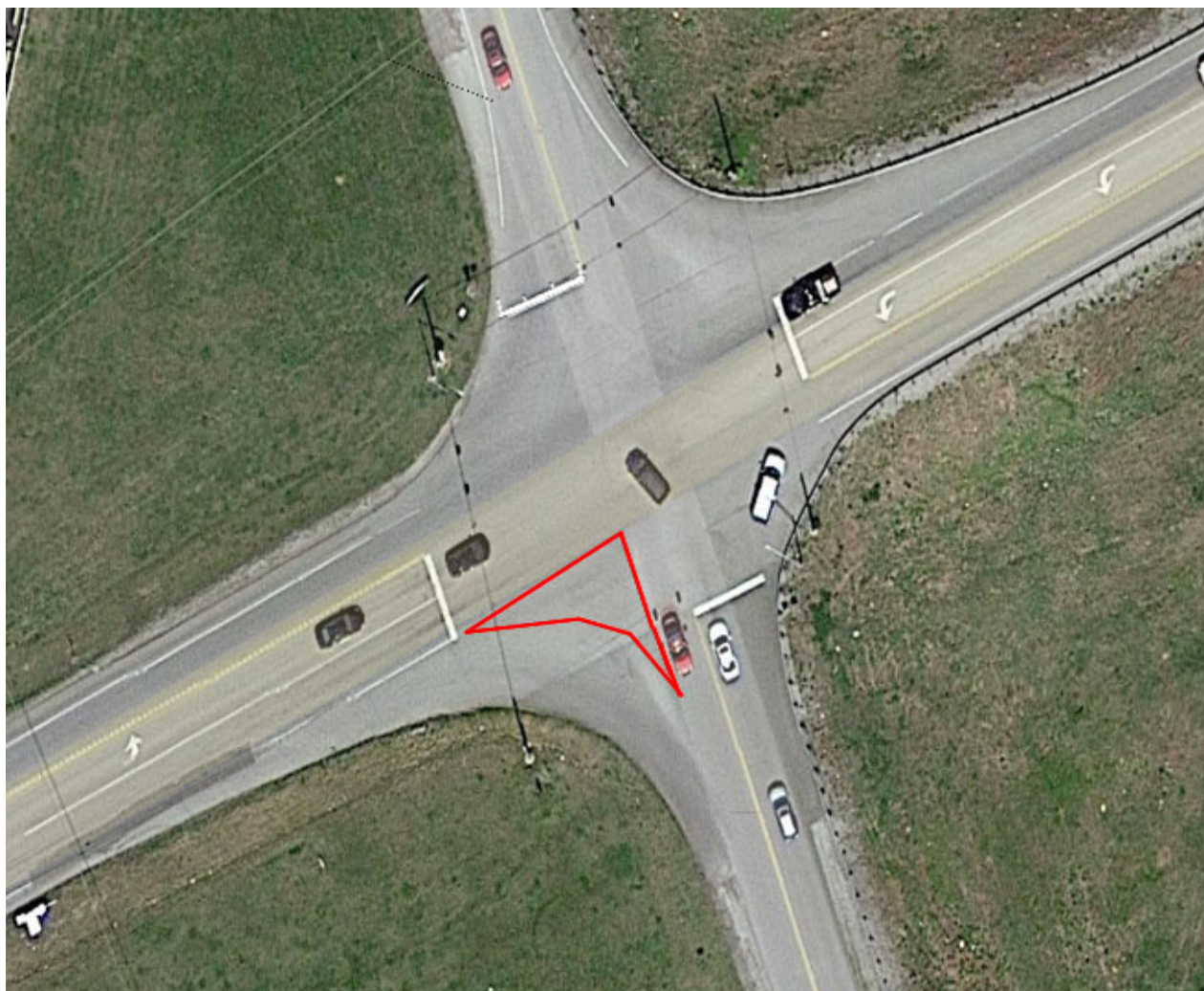

There is a lot of guardrail in the area. Install Bi-Directional Guardrail Delineators.

### Cabinet Replacement

The existing pole mounted cabinet is old and small. The existing left turn loops are currently not hooked up, because the pole mounted cabinet doesn't have enough detectors.

Existing service and signal pole will remain active. Just installing a new cabinet.

Install a new base mounted cabinet right next to the existing signal pole.

This will include moving existing wiring to the new cabinet and labeling wiring.

Multi conductor and Lead in have been setup in case new wires have to be ran to avoid splices.

KYTC will be available to help with the switch with programming from the old cabinet to the new one

Contact Traffic Engineer before any cabinet work to make sure everything is communicated correctly. Jake Riggs - 270 401 8132



The Department will retain all materials removed from the signal, they can be delivered to the Traffic Barn, located at 310 Valley Creek Road, Elizabethtown, KY 42701

Removal of all equipment is considered incidental to the installation of new poles, heads, cabinets etc.

Jeff Wolfe - Director

**DIVISION OF TRAFFIC OPERATIONS**

Phone (502) 564-3020  
 FAX (502) 564-7759

**RECOMMENDATION FOR PICKUP OF ITEMS TO BE INSTALLED  
 ON TRAFFIC SIGNALS/LIGHTING**

Item Number: 4-9005.50  
 County: Nelson  
 Description: KY 245 @ KY 1430  
(all heads to have reflective backplates)

Cabinets		
	Master code	
1	T-01-0020	Base Mounted 332 Cabinet
1	T-01-0105	ATC Controller
1	T-01-0106	1C w/Maxtime (this should go with item ATC controller)
1	T-01-0501	Conflict Monitor, Model 2018 <span style="background-color: red; color: white; padding: 2px;">Special Order</span>
6	T-01-0600	Loop Detector, Model 222
6	T-01-0700	Load Switches

Signals		
	Master code	
8	T-02-0009	Siemens 3 Section Signal
8	T-02-0032	Siemen 3 section backplate
4	T-02-0034	Siemen 4 section 12" signal double red
4	T-02-0042	4-sec dbl red backplate only
8	T-02-0080	12 inch red/yellowbeacon
2	T-02-0300	LED Module 12" red arrow
4	T-02-0310	LED Module 12" yellow arrow
14	T-02-0330	LED Module 12" red ball
18	T-02-0340	LED Module 12" yellow ball
10	T-02-0350	LED Module 12" green ball

Special items		
	Master code	
1	T-02-0504	Router (this includes power supply/antenna/cabling)
2	T-09-0410	Sign Hanger for 48" signs
2	T-02-0640	Mast arm mount signal bracket (3 section)
2	T-02-0645	Mast arm sign hangers 48"

Poles		
	Master code	
2	T-04-0030	Steel Strain Pole 32 foot
2	T-04-0040	Steel Strain Pole 34 foot

Electrical Contractor Name \_\_\_\_\_  
 Electrical Contractor Supervisor \_\_\_\_\_ Contact number for Supervisor \_\_\_\_\_  
 Project Engineer \_\_\_\_\_ Contact number for Project Engineer \_\_\_\_\_

Project Engineer attests that the mentioned contractor is the actual electrical contractor on this project

Signature of Project Engineer or Designee \_\_\_\_\_

<b>Nelson Co. KY 245 @ KY 1430 Summary of Items</b>			
<b>BID CODE</b>	<b>DESCRIPTION</b>	<b>UNIT</b>	<b>QUANTITY</b>
1987	DELINEATOR FOR GUARDRAIL B/W	EACH	250
2562	TEMPORARY SIGNS	SQFT	190
2650	MAINTAIN & CONTROL TRAFFIC KY245 @ KY1430	LS	1
2775	ARROW PANEL	EACH	1
6568	PAVE MARKING-THERMO STOP BAR-24 IN	LF	120
6574	PAVE MARKING-THERMO CURV ARROW	EACH	9
4811	ELECTRICAL JUNCTION BOX TYPE B	EACH	8
4820	TRENCHING AND BACKFILLING	LF	1920
4844	CABLE-NO. 14/5C	LF	5452
4850	CABLE-NO. 14/1 PAIR	LF	1850
4885	MESSENGER-10800 LB	LF	505
4932	INSTALL STEEL STRAIN POLE	EACH	4
24955ED	REMOVE SIGNAL EQUIPMENT	EACH	1
20094ES835	TEMPORARY RELOCATION OF SIGNAL HEAD	EACH	10
20188NS835	INSTALL SIGNAL-3 SECTION LED	EACH	8
20266ES835	INSTALL SIGNAL-4 SECTION LED	EACH	4
20390NS835	INSTALL COORDINATING UNIT	EACH	1
20408ES835	INSTALL LED BEACON-12 IN	EACH	4
21543EN	BORE AND JACK CONDUIT	LF	50
23157EN	TRAFFIC SIGNAL POLE BASE	CUYD	18
24901EC	PVC CONDUIT - 2 INCH - SCHEDULE 80	LF	2000
24908EC	INSTALL SIGNAL CONTROLLER-TY ATC	EACH	1
24525EC	ADVANCE WARNING FLASHER	EACH	2



**Nelson County - KY 245 @ KY 1430  
 Item No. 4-9006.5**

**Signal Head Improvements**

Total of 12 new Signal Heads to be installed with Reflective Backplates.

<b>Signal Head</b>	<b>Red Ball</b>	<b>Yellow Ball</b>	<b>Green Ball</b>	<b>R. Arrow</b>	<b>Y. Arrow</b>	<b>G. Arrow</b>
4 Section Double Red w/Ref. backplate	2	1	1			
4 Section Double Red w/Ref. backplate	2	1	1			
4 Section Double Red w/Ref. backplate	2	1	1			
4 Section Double Red w/Ref. backplate	2	1	1			
3 Sect. Flashing Yellow w/Ref. Backplate				1	2	
3 Sect. Flashing Yellow w/Ref. Backplate				1	2	
3 Section Signal Head w/Ref. backplate	1	1	1			
3 Section Signal Head w/Ref. backplate	1	1	1			
3 Section Signal Head w/Ref. backplate	1	1	1			
3 Section Signal Head w/Ref. backplate	1	1	1			
3 Section Signal Head w/Ref. backplate	1	1	1			
3 Section Signal Head w/Ref. backplate	1	1	1			
<b>Totals</b>	<b>14</b>	<b>10</b>	<b>10</b>	<b>2</b>	<b>4</b>	

**Signal Head Notes**

- Replace the 4 KY 245 thru lane heads with 4 section double reds with retroreflective backplates
- Replace the 4 sidestreet heads with new 3 section heads with retroreflective backplates.
- Replace the two 3 section Flashing Yellow Arrow heads for left turn lanes on KY 245.
- Add 2 new 3 section supplemental heads for the KY 245 approaches.

Contact Traffic Engineer before placing any signal heads to make sure everything is communicated correctly. Jacob Riggs - 270 401 8132

KY 245 Northbound



KY 245 Southbound



KY 1430 Northbound



Wedgewood Drive



### **Striping and Thermo Additions**

Install 9 Thermoplastic Arrows on asphalt  
Install 120' of 2' Thermoplastic Stop Bars

Note - Pavement is not in great shape, depending on resurfacing schedule, Traffic Engineer might remove the Thermoplastic from work if new pavement is about to be placed.

Contact Jake Riggs 270 401 8132 prior to any work to have layout approved and to make sure the thermoplastic work is to be completed

There is a lot of guardrail in the area. Install Bi-Directional Guardrail Delineators.

### **Cabinet Replacement & Installation of AWF**

Existing service and signal poles will remain active. Install new cabinet & AWF as shown on the Signal Plans  
This will include labeling wiring.

Multi conductor and Lead in have been setup in case new wires have to be ran to avoid splices.

KYTC will be available to help with the switch with programming from the old cabinet to the new one

Contact Traffic Engineer before any work to make sure everything is communicated correctly. Jake Riggs - 270 401 8132



The Department will retain all materials removed from the signal, they can be delivered to the Traffic Barn, located at 310 Valley Creek Road, Elizabethtown, KY 42701

Removal of all equipment is considered incidental to the installation of new poles, heads, cabinets etc.

Jeff Wolfe - Director

**DIVISION OF TRAFFIC OPERATIONS**

Phone (502) 564-3020  
FAX (502) 564-7759

**RECOMMENDATION FOR PICKUP OF ITEMS TO BE INSTALLED  
ON TRAFFIC SIGNALS/LIGHTING**

Item Number: 4-9006.60

County: Taylor

Description: US 68 @ KY 289  
(all heads to have reflective backplates)

Cabinets	Master code	
1	T-01-0020	Base Mounted 332 Cabinet
1	T-01-0105	ATC Controller
1	T-01-0106	1C w/Maxtime (this should go with item ATC controller)
1	T-01-0501	Conflict Monitor, Model 2018 <span style="background-color: red; color: white;">Special Order</span>
2	T-01-0510	Isolator, Model 242 (for ped detector and railroad)
6	T-01-0600	Loop Detector, Model 222
10	T-01-0700	Load Switches

Signals		
8	T-02-0009	Siemens 3 Section Signal
8	T-02-0032	Siemen 3 section backplate
2	T-02-0033	Siemen 4 section 12" signal (poly)
4	T-02-0034	Siemen 4 section 12" signal double red
4	T-02-0042	4-sec dbl red backplate only
2	T-02-0043	Siemen 4-sec. straight signal backplate
2	T-02-0090	Pedestrian signal housing
4	T-02-0300	LED Module 12" red arrow
8	T-02-0310	LED Module 12" yellow arrow
2	T-02-0320	LED Module 12" green arrow
14	T-02-0330	LED Module 12" red ball
10	T-02-0340	LED Module 12" yellow ball
10	T-02-0350	LED Module 12" green ball
2	T-02-0365	LED Countdown Pedestrian Module

Special items		
1	T-02-0504	Router (this includes power supply/antenna/cabling)
1	T-09-0415	30 X 36 through 36 X 36 sign hanger (New)
2	T-02-0640	Mast arm mount signal bracket (3 section)
2	T-06-0710	Ped Detector Pole Mount FSA Box
2	T-06-0730	Ped Button w/o Plunger
2	T-17-0015	9 X 15 Countdown Ped Sign DBL Sided

Poles		
1	T-04-0020	Steel Strain Pole 30 foot

Electrical Contractor Name \_\_\_\_\_  
 Electrical Contractor Supervisor \_\_\_\_\_  
 Project Engineer \_\_\_\_\_

Contact number for Supervisor \_\_\_\_\_  
 Contact number for Project Engineer \_\_\_\_\_

Project Engineer attests that the mentioned contractor is the actual electrical contractor on this project

Signature of Project Engineer or Designee \_\_\_\_\_

Taylor Co. US 68 @ KY 289 Summary of Items			
BID CODE	DESCRIPTION	UNIT	QUANTITY
2562	TEMPORARY SIGNS	SQFT	190
2650	MAINTAIN & CONTROL TRAFFIC US68 @ KY 289	LS	1
2775	ARROW PANEL	EACH	1
4960	REMOVE AND REPLACE SIDEWALK	SQYD	2
5990	SODDING	SQYD	80
23158ES505	DETECTABLE WARNINGS	SQFT	10
6566	PAVE MARKING-THERMO X-WALK 6 IN	LF	460
6568	PAVE MARKING-THERMO STOP BAR-24 IN	LF	120
6574	PAVE MARKING-THERMO CURV ARROW	EACH	9
4792	CONDUIT 1 INCH	LF	25
4811	ELECTRICAL JUNCTION BOX TYPE B	EACH	2
4820	TRENCHING AND BACKFILLING	LF	160
4830	LOOP WIRE	LF	350
4844	CABLE-NO. 14/5C	LF	2545
4850	CABLE-NO. 14/1 PAIR	LF	1725
4884	ANCHOR	EACH	2
4886	MESSENGER-15400 LB	LF	175
4895	LOOP SAW SLOT AND FILL	LF	115
4932	INSTALL STEEL STRAIN POLE	EACH	1
24955ED	REMOVE SIGNAL EQUIPMENT	EACH	1
6472	INSTALL SPAN MOUNTED SIGN	EACH	1
20093NS835	INSTALL PEDESTRIAN HEAD LED	EACH	2
20094ES835	TEMPORARY RELOCATION OF SIGNAL HEAD	EACH	10
20390NS835	INSTALL COORDINATING UNIT	EACH	1
21743NN	INSTALL PEDESTRIAN DETECTOR	EACH	2
23157EN	TRAFFIC SIGNAL POLE BASE	CUYD	5
24900EC	PVC CONDUIT - 1 1/4 INCH - SCHEDULE 80	LF	165
24901EC	PVC CONDUIT - 2 INCH - SCHEDULE 80	LF	80
24908EC	INSTALL SIGNAL CONTROLLER-TY ATC	EACH	1
20188NS835	INSTALL LED SIGNAL-3 SECTION	EACH	8
20266ES835	INSTALL LED SIGNAL-4 SECTION	EACH	6

**Taylor County - US 68 @ KY 289  
 Item No. 4-9006.60**

**Signal Head Improvements**

Total of 14 new Signal Heads to be installed with Reflective Backplates.

Signal Head	Red Ball	Yellow Ball	Green Ball	R. Arrow	Y. Arrow	G. Arrow
4 Section double Red w/Ref. backplate	2	1	1			
4 Section double Red w/Ref. backplate	2	1	1			
4 Section double Red w/Ref. backplate	2	1	1			
4 Section double Red w/Ref. backplate	2	1	1			
3 Section Signal Head w/Ref. backplate	1	1	1			
3 Section Signal Head w/Ref. backplate	1	1	1			
3 Section Signal Head w/Ref. backplate	1	1	1			
3 Section Signal Head w/Ref. backplate	1	1	1			
3 Section Signal Head w/Ref. backplate	1	1	1			
3 Section Signal Head w/Ref. backplate	1	1	1			
3 Sect. Flashing Yellow w/Ref. Backplate				1	2	
3 Sect. Flashing Yellow w/Ref. Backplate				1	2	
4 Section Flashing Yellow w/Ref. Backplate				1	2	1
4 Section Flashing Yellow w/Ref. Backplate				1	2	1
<b>Totals</b>	<b>14</b>	<b>10</b>	<b>10</b>	<b>4</b>	<b>8</b>	<b>2</b>

**Signal Head Notes**

- Install all new 3 section heads with reflective backplates for all side street approaches.
- Install 4 new 4 section double red heads for mainline through approaches
- Install 2 new 3 section supplemental heads for US 68 approaches.
- Install 2 new 4 section flashing yellow arrow heads with reflective backplates for US 68 turn lanes.

Contact Traffic Engineer before placing any signal heads to make sure everything is communicated correctly. Jacob Riggs - 270 401 8132

US 68 Eastbound

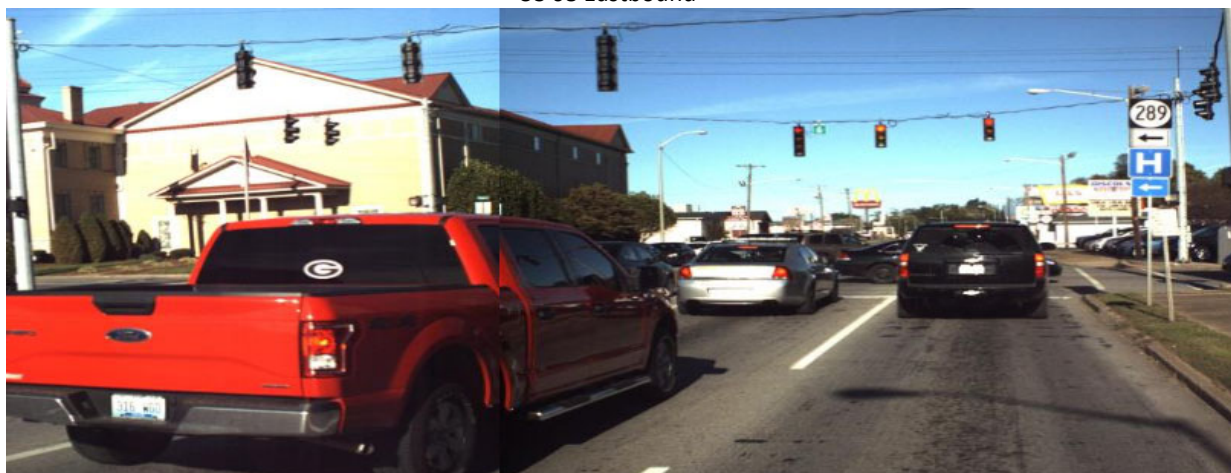

US 68 Westbound



KY 289 Southbound



Lebanon Ave. Northbound



### **Signal Loop Additions**

Install 4 new 6x6 loops about 100 feet back from stop bars on US 68 as shown on the Signal Plans  
Want to avoid all the concrete entrances and utilites, planning on staying in the utility strip.  
Install new conduit and junction boxes for lead in wire.

\*Contact Traffic Engineer (270-766-5066) before cutting loops and installing conduit and junction boxes.



Small amount of sidewalk that will have to be dug up and later replaced. Existing spot already there.



### **Cabinet and Pole Replacement**

The existing pole and cabinet are completely log jammed with old small conduits and locked up ridged steel. Install new pole and new cabinet as shown on the Signal Plans.

This will include labeling wiring.

Multi conductor and Lead in have been setup in case new wires have to be ran to avoid splices.

KYTC will be available to help with the switch with programming from the old cabinet to the new one.

It will also include building a new service to get the signal transferred over.

There is a sidewalk quantity setup for sidewalk damaged during the construction.

As well as sodding for grass area disturbed while installing signal equipment.

Pedestrian Heads and Pedestrian Detectors are setup for the new steel strain are for moving the old Pedestrian Heads and Pedestrian Detectors over from the old pole to the new pole.

Contact Traffic Engineer before any cabinet work to make sure everything is communicated correctly. Jake Riggs - 270 401 8132



The Department will retain all materials removed from the signal, they can be delivered to the Traffic Barn, located at 310 Valley Creek Road, Elizabethtown, KY 42701.

Removal of all equipment is considered incidental to the installation of new poles, heads, cabinets etc.

### **Striping and Thermo Additions**

Install 9 Thermoplastic Arrows on asphalt

Install 120' of 24" Thermoplastic Stop Bars

Install 460' of 6" Thermoplastic stripe for crosswalks

MicroStation v8.11.7.443 E-SHEET NAME: T001005U USER: charles.weitzel DATE PLOTTED: January 22, 2019 FILE NAME: C:\USERS\CHARLES.WEITZEL\DESKTOP\4-9006\TUESDAY\T001005L.DGN

8-3-2018

NELSON COUNTY KY 245 @ KY 1430		TAYLOR COUNTY US 68 & KY 289		TOTAL	TOTAL UNITS	CODE	ITEM DESCRIPTION
0	25	25	4792				CONDUIT 1 INCH
8	2	10	481				ELECTRICAL JUNCTION BOX TYPE B
1920	160	2,080	4820				TRENCHING AND BACKFILLING
0	350	350	4830				LOOP WIRE
5452	2545	7,997	4844				CABLE-NO. 14/5C
1850	1725	3,575	4850				CABLE-NO. 14/1 PAIR
0	2	2	4884				ANCHOR
505	0	505	4885				MESSSENGER-10800 LB
0	175	175	4886				MESSSENGER-15400 LB
0	115	115	4895				LOOP SAW SLOT AND FILL
4	1	5	4932				INSTALL STEEL STRAIN POLE
1	1	2	249596d				REMOVE SIGNAL EQUIPMENT
0	2	2	4950				REMOVE AND REPLACE SIDEWALK
0	1	1	6472				INSTALL SPAN MOUNTED SIGN
0	2	2	2009NS835				INSTALL PEDESTRIAN HEAD LED
10	10	20	20094E835				TEMPORARY RELOCATION OF SIGNAL HEAD
8	16	24	2018NS835				INSTALL SIGNAL-3 SECTION LED
4	6	10	2026E835				INSTALL SIGNAL-4 SECTION LED
1	1	2	2039NS835				INSTALL COORDINATING UNIT
4	4	8	2049E835				INSTALL LED BEACON-12 IN
50	0	50	2143EN				BORE AND JACK CONDUIT
0	2	2	2315EN				INSTALL PEDESTRIAN DETECTOR
18	5	23	2315EN				TRAFFIC SIGNAL POLE BASE
0	165	165	24900EC				PVC CONDUIT - 1 1/4 INCH - SCHEDULE 80
2000	80	2,080	2490EC				PVC CONDUIT - 2 INCH - SCHEDULE 80
1	1	2	2490BEC				INSTALL SIGNAL CONTROLLER-TY ATC
2	0	2	2429SEC				ADVANCE WARNING FLASHER

THE STANDARD SPECIFICATIONS FOR ROAD AND BRIDGE CONSTRUCTION, CURRENT EDITION, AND OTHER SPECIAL NOTES AND SPECIFICATIONS WILL APPLY ON THIS PROJECT. SEE SECTION 706, 723, AND 12 FOR MEASUREMENT AND OTHER DETAILS. SEE SECTION 602 FOR SPIRAL REINFORCEMENT SPLICING.

THE CONTRACTOR SHALL MAKE AN INSPECTION OF THE PROJECT SITE PRIOR TO SUBMITTING A BID AND SHALL BE THOROUGHLY FAMILIARIZED WITH EXISTING CONDITIONS AND THE PROVISIONS OF THE SPECIFICATIONS. THE CONTRACTOR SHALL INSPECTION HAVING BEEN COMPLETED.

THE CONTRACTOR SHALL BE RESPONSIBLE FOR PICKING UP INSTALL ITEMS FROM THE FRANKFORT POLE YARD AND DELIVERING THESE ITEMS TO THE SITE. THE CONTRACTOR SHALL CONTACT FRANKFORT POLE YARD PERSONNEL (502-782-8994/502-782-8995) FOR THE LOCATION OF THE FRANKFORT POLE YARD. ALL ITEMS A LISTING OF TWO (2) WORKING DAYS PRIOR TO ARRIVAL. THE CONTRACTOR SHALL ALSO CONTACT THE SIGNAL SYSTEM BRANCH (502-782-5543/502-782-5547 OR EMAIL: JOE.THOMPSON@KY.GOV/ LARRY.JRISH@KY.GOV) TO ARRANGE PROGRAMMING OF THE ROUTER USED FOR COMMUNICATION IN THE TRAFFIC SIGNAL. A MINIMUM OF TWO (2) WORKING DAYS PRIOR TO ARRIVAL. FAILURE TO PROVIDE POLE YARD PERSONNEL/ SIGNAL SYSTEM BRANCH THIS ADVANCE NOTICE COULD RESULT IN LONG DELAYS OR REFUSAL TO DISBURSE EQUIPMENT UPON ARRIVAL.

ADD SENTENCE TO SECTION 835.19: ALL WIRE SHALL HAVE WORKING ADDED TO THE OUTER JACKET THAT STATES: "PROPERTY OF KENTUCKY TRANSPORTATION CABINET 502 564 050".

CONSTRUCTION AND MEASUREMENT NOTES THAT ARE CONTRARY TO SECTION 723

REVISION	DESCRIPTION
04-22	REMOVE SIGNAL EQUIPMENT. (CONSTRUCTION ONLY)
	REPLACE THE PARAGRAPH WITH THE FOLLOWING: THE DEPARTMENT WILL MEASURE THE QUANTITY BY EACH OF THE MATERIALS ASSOCIATED WITH ANY STRUCTURAL OR ELECTRICAL COMPONENT OF THE SIGNAL SYSTEM INCLUDING, BUT NOT LIMITED TO POLE BASES, POLES, JUNCTION BOXES, CABINETS, AND WOOD POLES FOR PAYMENT AND WILL CONSIDER THEM INCIDENTAL TO THIS ITEM OF WORK.

SUBSECTION	MAX SERVICE MOMENT (FT-KIPS)	DIAMETER (IN.)	DEPTH (FEET)		VERTICAL SLOPE		VERTICAL BARS	TIES OR SPIRAL
			SOIL	ROCK	SOIL	ROCK		
0-3-9	10.3	36	6	6	6-5	6	8	4
1-3-9	10.3	36	6	6	6-5	6	8	4
2-3-9	10.3	36	6	6	6-5	6	8	4
3-3-9	10.3	36	6	6	6-5	6	8	4
4-3-9	10.3	36	6	6	6-5	6	8	4
5-3-9	10.3	36	6	6	6-5	6	8	4
6-3-9	10.3	36	6	6	6-5	6	8	4
7-3-9	10.3	36	6	6	6-5	6	8	4
8-3-9	10.3	36	6	6	6-5	6	8	4
9-3-9	10.3	36	6	6	6-5	6	8	4
10-3-9	10.3	36	6	6	6-5	6	8	4
11-3-9	10.3	36	6	6	6-5	6	8	4
12-3-9	10.3	36	6	6	6-5	6	8	4
13-3-9	10.3	36	6	6	6-5	6	8	4
14-3-9	10.3	36	6	6	6-5	6	8	4
15-3-9	10.3	36	6	6	6-5	6	8	4
16-3-9	10.3	36	6	6	6-5	6	8	4
17-3-9	10.3	36	6	6	6-5	6	8	4
18-3-9	10.3	36	6	6	6-5	6	8	4
19-3-9	10.3	36	6	6	6-5	6	8	4
20-3-9	10.3	36	6	6	6-5	6	8	4
21-3-9	10.3	36	6	6	6-5	6	8	4
22-3-9	10.3	36	6	6	6-5	6	8	4
23-3-9	10.3	36	6	6	6-5	6	8	4
24-3-9	10.3	36	6	6	6-5	6	8	4
25-3-9	10.3	36	6	6	6-5	6	8	4

Commonwealth of Kentucky  
DEPARTMENT OF HIGHWAYS  
COUNTY OF

TRAFFIC SIGNAL  
ESTIMATE OF QUANTITIES  
MEASUREMENT, CONSTI, AND MISC NOTES

DESIGNED BY: CW  
DATE SUBMITTED:

PROJECT NUMBER: \_\_\_\_\_  
MEASUREMENT, CONSTI, AND MISC NOTES

MicroStation v8.11.7.443 E-SHEET NAME: T00200CA USER: charles.weitzel DATE PLOTTED: January 22, 2019 FILE NAME: C:\USERS\CHARLES.WEITZEL\DESKTOP\4-9006\TUESDAY\T00200CA.DGN

5/30/2017  
SEE POLE BASE DETAIL SHEET FOR GROUNDING DETAILS.

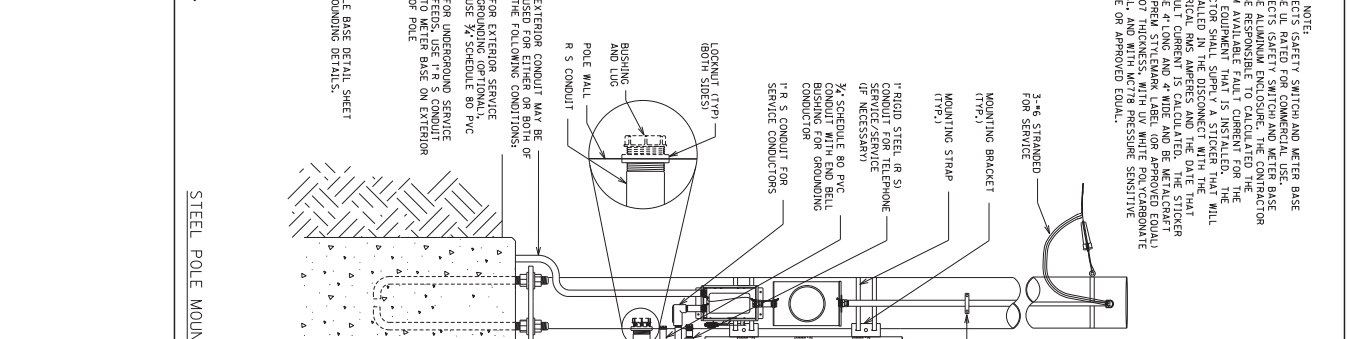

**SPECIAL NOTE:**  
ALL SAFETY SWITCH AND METER BASE SHALL BE US RATED FOR COMMERCIAL USE. DISCONNECTS SAFETY SWITCH AND METER BASE SHALL BE ALUMINUM ENCLOSURE. THE CONTRACTOR SHALL BE AVAILABLE TO SUPPLY CURRENT FOR THE METER EQUIPMENT THAT IS INSTALLED. THE CONTRACTOR SHALL SUPPLY A STICKER THAT WILL BE PLACED ON THE METER EQUIPMENT. THIS FAULT CURRENT IS CALCULATED. THE STICKER SHALL BE LONG AND WIDE AND BE REPEATED EVERY 1/2\"/>

**NOTES:**  
ALL CONDUITS USED FOR THE TELEPHONE, GROUNDING, SPARES, AND SERVICE (INCLUDING FLEX CONDUIT IF IT IS RUN INSIDE THE POLE THAT ARE INSTALLED ON THE POLE AND/OR IN THE CABINET BASE ARE INCIDENTAL TO THE POLE AND SHALL BE INSTALLED INSIDE THE CONDUIT PAST THE EDGE OF THE CONCRETE PAD. ALL CONDUITS SHALL BE INSTALLED BETWEEN 4 TO 6 INCHES ABOVE THE CONCRETE PAD, AND THE CONDUIT SHALL BE 6 INCHES ABOVE THE SERVICE WIRES FROM BASE MOUNTED CABINETS MAY BE INSTALLED INSIDE THE CONDUIT. THE CONTRACTOR SHALL BE RESPONSIBLE FOR THE PROPER CONNECTIONS FOR THE TRANSITION FROM FLEXIBLE CONDUIT TO R/S CONDUIT. FLEXIBLE CONDUIT SHALL BE INSTALLED ON THE HAND HOLE OR THE ABILITY TO ACCESS THE GROUNDING SYSTEM.

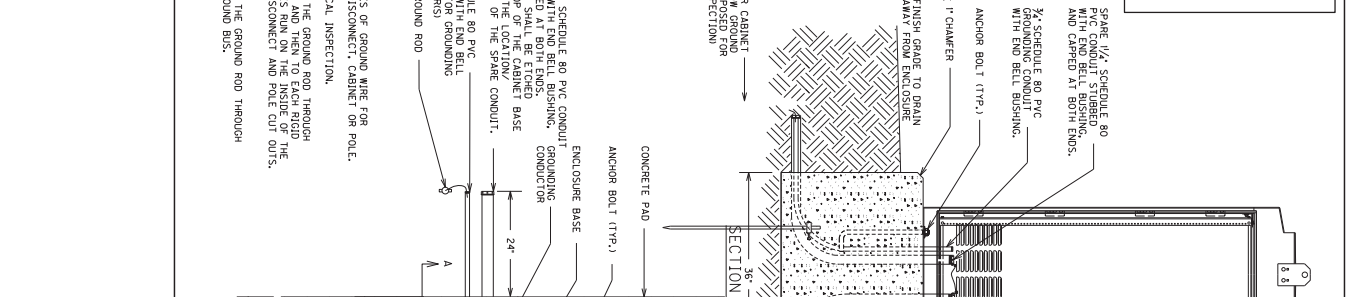

**ROUTER INSTALLATION (REAR OF CABINET)**  
4. 2 (MIN.) SCHEDULE 80 PVC CONDUITS SHALL BE INSTALLED IN ORDER TO PROVIDE 1 NEC REQUIREMENTS.  
1. R/S CONDUIT FOR SERVICE (IF NECESSARY)

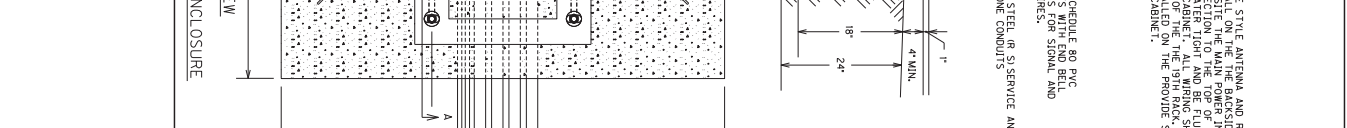

**PAD MOUNT ENCLOSURE**  
CONTRACTOR SHALL PROVIDE A MINIMUM OF 6 INCHES OF GROUND WIRE FOR TESTING PRIOR TO CONNECTING THE WIRE TO ANY DISCONNECT, CABINET OR POLE. LEAVE TOP OF GROUND RODS EXPOSED FOR ELECTRICAL INSPECTION.  
SERVICE GROUND - GROUND WIRE SHALL COME FROM THE GROUND ROD THROUGH THE STEEL IR SIG GROUNDING BUSHING. IF GROUND WIRE IS RUN ON THE INSIDE OF THE STEEL IR SIG GROUNDING BUSHING, THE DISCONNECT AND POLE COT 4931, THEY SHALL BE INCIDENTAL TO BID ITEM 4931.  
CABINET GROUND - GROUND WIRE SHALL COME FROM THE GROUND ROD THROUGH THE PVC CONDUIT, CONNECTING TO THE CABINET GROUND BOX.

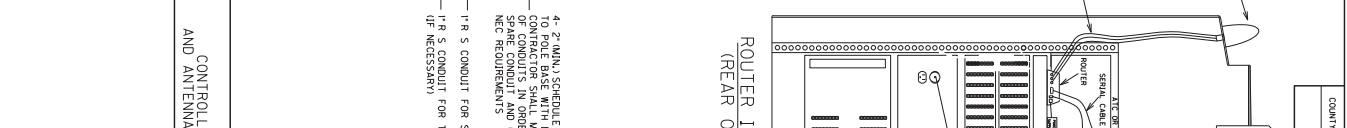

**GROUNDING REQUIREMENTS:**  
CONTRACTOR SHALL PROVIDE A MINIMUM OF 6 INCHES OF GROUND WIRE FOR TESTING PRIOR TO CONNECTING THE WIRE TO ANY DISCONNECT, CABINET OR POLE. LEAVE TOP OF GROUND RODS EXPOSED FOR ELECTRICAL INSPECTION.  
SERVICE GROUND - GROUND WIRE SHALL COME FROM THE GROUND ROD THROUGH THE STEEL IR SIG GROUNDING BUSHING. IF GROUND WIRE IS RUN ON THE INSIDE OF THE STEEL IR SIG GROUNDING BUSHING, THE DISCONNECT AND POLE COT 4931, THEY SHALL BE INCIDENTAL TO BID ITEM 4931.  
CABINET GROUND - GROUND WIRE SHALL COME FROM THE GROUND ROD THROUGH THE PVC CONDUIT, CONNECTING TO THE CABINET GROUND BOX.

COUNTY OF	ITEM NO.	SHEET NO.
	4-9006-5	72

MicroStation v8.11.7.443 E-SHEET NAME: T00300LP USER: charles.weitzel DATE PLOTTED: January 22, 2019 FILE NAME: C:\USERS\CHARLES.WEITZEL\DESKTOP\4-9006\TUESDAY\T00300LP.DGN

**6'x6' LOOP SECTION A-A (SAW SLOT DETAIL)**

PROPOSED FINISHED SURFACE  
NON-SHRINK GROUT IN 1/2" SAW SLOT  
1/2" BACKER ROD IN 1/2" SAW SLOT  
LOOP WIRES ENCAPSULATED IN LOOP SEALANT IN 1/2" SAW SLOT  
MAXIMUM NUMBER OF WIRES IN A SINGLE SAW SLOT IS 6

**ASPHALT SAW SLOT DETAIL FOR PREFORMED**

PROPOSED FINISHED SURFACE  
NON-SHRINK GROUT IN 3/4" SAW SLOT  
1" BACKER ROD IN 3/4" SAW SLOT  
PREFORMED LOOP IN 3/4" SAW SLOT

PREFORMED LOOPS SHALL BE CONSTRUCTED WITH 1/4" OR SMALLER HEAVY DUTY REINFORCED RUBBER HOSE (CLASS A OIL RESISTANT, TEMPERATURE SYNTHETIC RUBBER, STANDARD WIRE SHALL BE WATER RATED #16 THIN OR TFFN).  
MAXIMUM NUMBER OF WIRES IN A TUBE PER SLOT IS 4.  
MAXIMUM NUMBER OF TUBES PER SLOT IS 1.

**6'x6' LOOP SAW CUT PLAN**

CORE DRILL 1/2" HOLE AND/OR CHISEL CORNER TO ELIMINATE SHARP EDGES

1/2" SAW SLOT

EXTEND CUT BEYOND CORNER TO ACHIEVE FULL DEPTH

TO PULL BOX OR CONTROL BOX

**6'x6' LOOP LOOP WIRE PLAN**

NUMBER OF TURNS SPECIFIED ON LAYOUT DETAIL SHEET

**6'x30' QUADRANGLE LOOP SAW CUT PLAN**

EXTEND CUT BEYOND CORNER TO ACHIEVE FULL DEPTH

TO PULL BOX OR CONTROL BOX

**6'x30' QUADRANGLE LOOP LOOP WIRE PLAN**

NUMBER OF TURNS SPECIFIED ON LAYOUT DETAIL SHEET

**6'x6' LOOP SAW SLOT EDGE OF PAVEMENT TRANSITION**

1/8" x 5/8" CONDUIT TO APPLICATOR BOX OR CABINET  
18" MIN. DEPTH

1" RISER ELBOW

9'-12"

PAVED SURFACE

LOOP WIRES IN SAW SLOT

EDGE OF PAVED SURFACE OF CURB

DRILL 1/2" DIAMETER HOLE FROM SAW SLOT (9'-12" FROM SHOULDER OR FACE OF CURB) TO CONDUIT AND INSTALL 1" RIGID STEEL CONDUIT.

**6'x6' LOOP PREFORMED LOOP LOOP WIRE PLAN**

PREFORMED LOOP LEAD-IN SHALL BE THREADED WITH THREE TO FIVE TURNS PER FOOT UNTIL TERMINATED AT FIELD SHIELDED CABLE.

PREFORMED LOOP LEAD-IN

TEE

PLACE TUBE UNDER PAVEMENT

TO PULL BOX OR CONTROL BOX

NUMBER OF TURNS SPECIFIED ON LAYOUT DETAIL SHEET

**6'x30' QUADRANGLE PREFORMED LOOP LOOP WIRE PLAN**

PREFORMED LOOP LEAD-IN SHALL BE THREADED WITH THREE TO FIVE TURNS PER FOOT UNTIL TERMINATED AT FIELD SHIELDED CABLE.

PREFORMED LOOP LEAD-IN

TEE

PLACE TUBE UNDER PAVEMENT

TO PULL BOX OR CONTROL BOX

NUMBER OF TURNS SPECIFIED ON LAYOUT DETAIL SHEET

**6'x30' QUADRANGLE PREFORMED LOOP LOOP WIRE PLAN**

PREFORMED LOOP LEAD-IN SHALL BE THREADED WITH THREE TO FIVE TURNS PER FOOT UNTIL TERMINATED AT FIELD SHIELDED CABLE.

PREFORMED LOOP LEAD-IN

TEE

PLACE TUBE UNDER PAVEMENT

TO PULL BOX OR CONTROL BOX

NUMBER OF TURNS SPECIFIED ON LAYOUT DETAIL SHEET

**CONSTRUCTION DETAILS FOR LOOP SAW SLOT AND FILL BID ITEM**

THE FOLLOWING IS A TYPICAL STEP BY STEP PROCEDURE FOR THE CONSTRUCTION OF A LOOP SAW SLOT:

- 1. MARK THE LOCATION OF THE SAW SLOT ON THE PAVED SURFACE.
- 2. CAREFULLY MARK THE SLOT TO BE CUT, PERPENDICULAR TO THE FLOW OF TRAFFIC AND CENTERED IN THE LANE AND AT A DEPTH SUCH THAT THE TOP OF THE BACKER ROD IS A MINIMUM OF 4 INCHES BELOW THE SURFACE OF ASPHALT PAVEMENT.
- 3. DRILL A 1/2" CORE HOLE AT EACH CORNER AND USE A CHISEL TO SMOOTH THE CORNERS TO PREVENT SHARP BENDS IN THE WIRE.
- 4. CLEAN ALL FOREIGN AND LOOSE MATTER OUT OF THE SLOTS, GRITTED CORES, COMPLETELY DRY THE SLOTS, DRILLED CORES, AND WITHIN FOOT ON ALL SIDES OF THE SLOTS.
- 5. FROM THE EDGE OF THE PAVED SURFACE, SQUARELY BREAK OR FACE OF CURB AND DRILL A 1/2" HOLE ON A 45 DEGREE ANGLE TO THE CONDUIT ADJACENT TO THE ROADWAY, AND SLOTS FOR JAGGED EDGES OR PROTRUSIONS PRIOR TO THE PLACEMENT OF THE WIRE.
- 6. ALL JAGGED EDGES OR PROTRUSIONS SHALL BE GROUND OR RE-CUT AND CLEANED AGAIN.
- 7. INSTALL RIGID STEEL CONDUIT AS DESCRIBED WITH PROPER JOINTS AND JOINT PROTECTIONS SHALL BE PROVIDED TO THE TERMINATION POINT.
- 8. PLACE THE LOOP WIRE SPICE-FREE FROM THE TERMINATION POINT AS A WORKER GUIDES THE WIRE INTO THE SAW SLOT WITH A RIGID OBJECT SUCH AS A WOODEN PUNCH.
- 9. THE WIRE SHALL BE THREADED THROUGH THE SAW SLOT TO THE BOTTOM OF THE SAW SLOT. SPREADERS SHALL NOT BE USED.
- 10. INSTALL DUCT SEALANT TO A MINIMUM OF 1 INCH DEEP INTO THE CORED 1/2" HOLE.
- 11. APPLY LOOP SEALANT FROM THE BOTTOM UP AND FULLY ENCAPSULATE THE LOOP WIRES IN THE SAW SLOT. THE WIRE SHOULD NOT BE ABLE TO MOVE WHEN THE SEALANT IS FULLY CURED.
- 12. COVER THE ENCAPSULATED LOOP WIRE WITH A CONTINUOUS LAYER OF BACKER ROD ALONG THE ENTIRE LOOP AND HOLE RUN SAW SLOTS SUCH THAT NO VOIDS REMAIN.
- 13. FINISH FILLING THE SAW CUT WITH NON-SHRINKABLE GROUT PER MANUFACTURER'S INSTRUCTIONS. ALLEVATE ALL AIR POCKETS AND REFILL LOW SPACES. THERE SHALL BE NO AIR TRAPPED UNDER THE GROUT.
- 14. CLEAN UP THE SITE AND DISPOSE OF ALL WASTE OF THE PROJECT TO ADEQUATE TRAFFIC CURING TIME VARIES WITH TEMPERATURE AND HUMIDITY.

COUNTY OF	ITEM NO.	SHEET NO.
4-9006, 5		73

MicroStation v8.11.7.443 E-SHEET NAME: T00400PO USER: charles.weitzel DATE PLOTTED: January 22, 2019 FILE NAME: C:\USERS\CHARLES.WEITZEL\DESKTOP\4-9006\TUESDAY.T00400PO.DGN

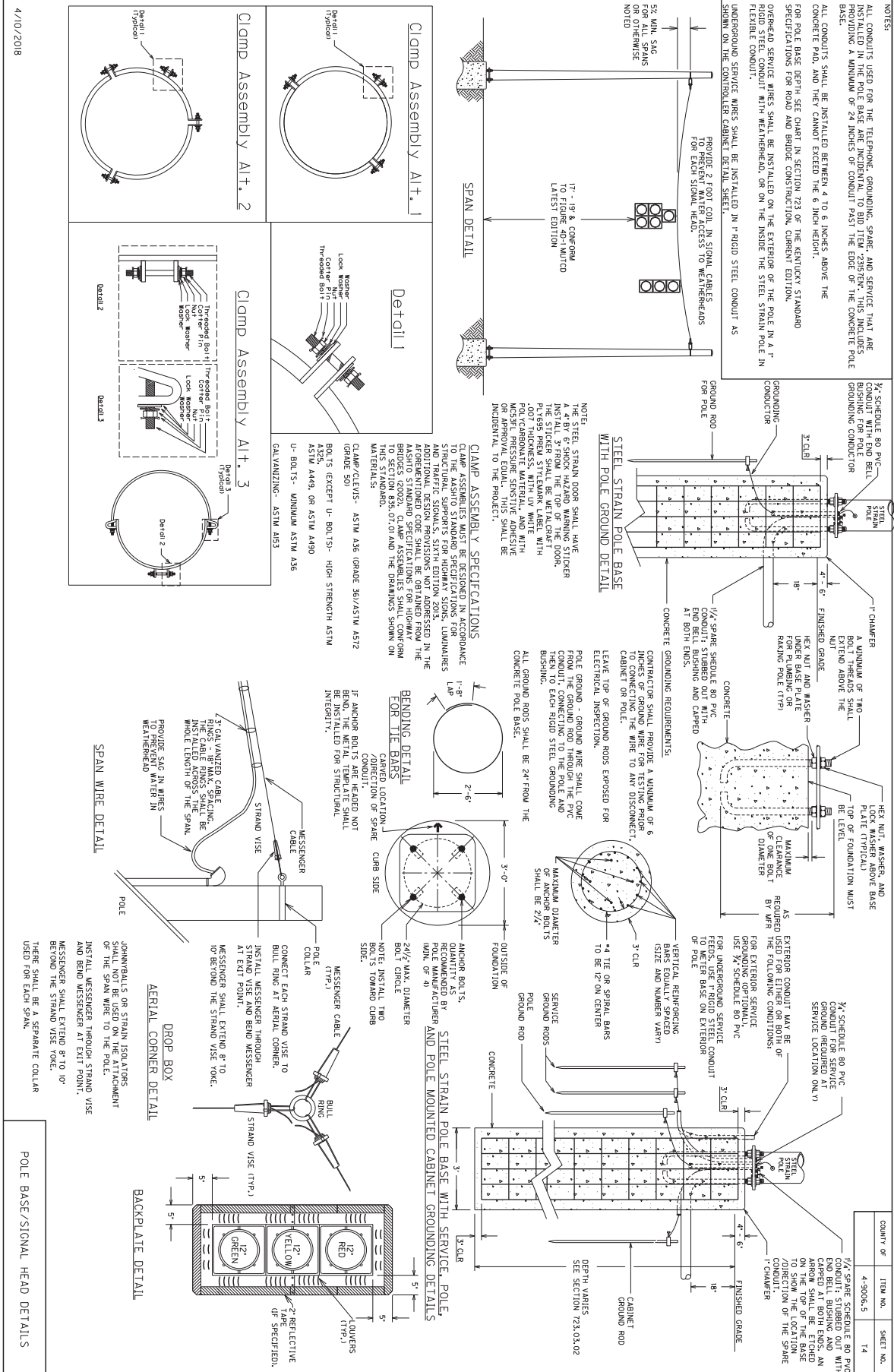

COUNTY OF	ITEM NO.	SHEET NO.
	4-9006.5	T4



MicroStation v8.11.7.443 E-SHEET NAME: T0060PO USER: charles.weitzel FILE NAME: C:\USERS\CHARLES.WEITZEL\DESKTOP\4-9006\TUESDAY\T0060PO.DGN  
DATE PLOTTED: January 22, 2019

6/22/2012

PEDESTAL POST DETAIL FOR PED DETECTORS & SIGNS

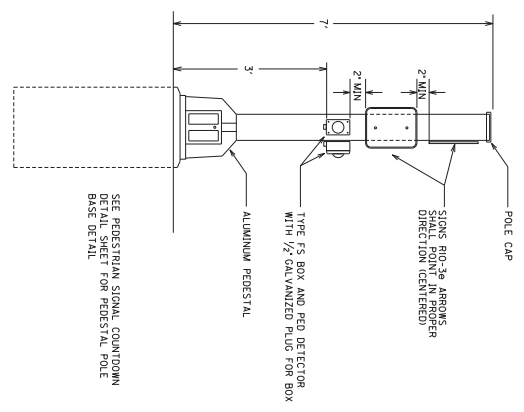

TYPE FS BOX FOR PED DETECTOR FOR USE WITH STEEL STRAIN POLE, WOOD POST, PEDESTAL, AND WOOD POLE

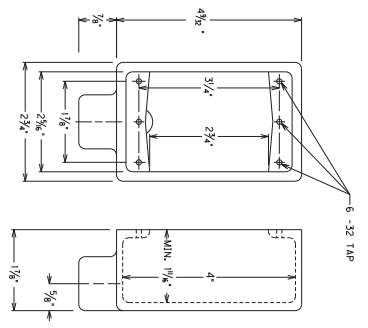

RIO-3a SIGN (9" X 15") FOR COUNTDOWN ONLY

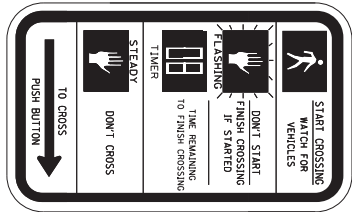

PED DETECTOR ON WOOD POST DETAIL

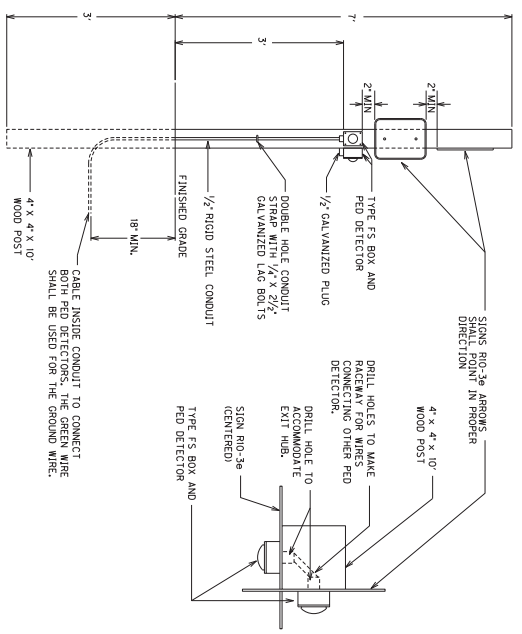

\*9 X 1/2 PAN HEAD OR ROUND HEAD WOOD SCREWS TO SECURE BOX TO POST. MINIMUM OF 2 SCREWS FOR EACH BOX. SCREWS SHALL BE INSTALLED DIAGONALLY.

PED DETECTOR

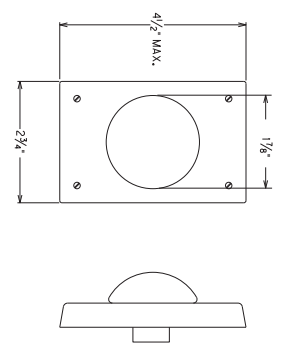

PEDESTRIAN DETECTOR DETAIL

COUNTY OF	ITEM NO.	SHEET NO.
	4-9006.5	16

MicroStation v8.11.7.443 E-SHEET NAME: T00700.B USER: charles.weitzel DATE PLOTTED: January 22, 2019 FILE NAME: C:\USERS\CHARLES.WEITZEL\DESKTOP\4-9006\TUESDAY\T00700.B.DGN

3/13/2017

TEST/PIPE PLUG FOR SPARE CONDUITS) AND GROUNDING DETAIL CONCRETE CABLE MARKERS

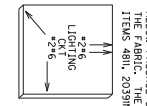
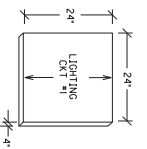
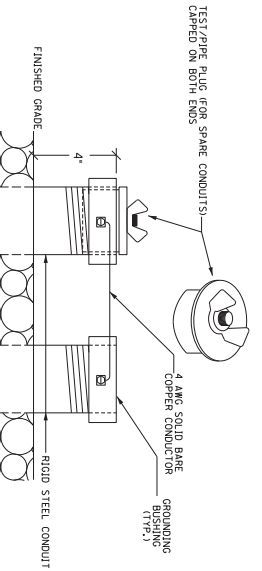

ABOVE GROUND BOX

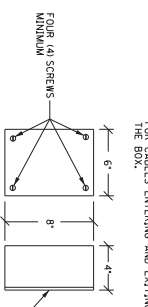

JUNCTION BOX INSTALLATION FOR CONVENTIONAL LIGHTING

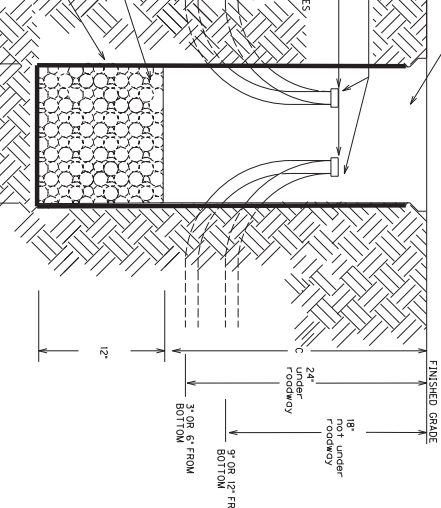

JUNCTION BOX INSTALLATION FOR HIGHWAY LIGHTING

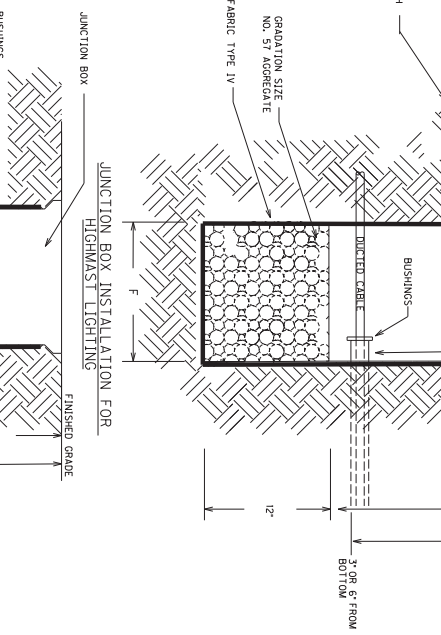

CONDUIT INSTALLATION UNDER EXISTING PAVEMENT DETAIL

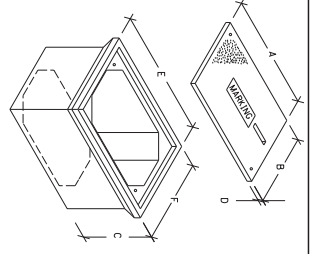
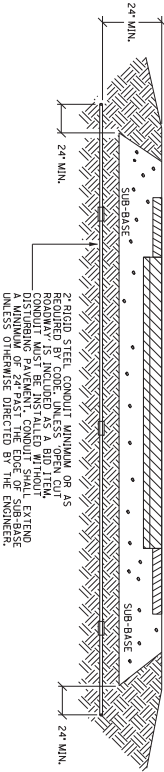

JUNCTION BOX DIMENSIONS (INCH)						
	A	B	C	D	E	F
TYPE A	23"	14"	27"	2"	25"	15"
TYPE B	18"	11"	12"	1 1/2"	20"	13"
TYPE C	36"	24"	30"	3"	38"	26"

\* MINIMUM  
NOTE: STACKABLE BOXES ARE PERMITTED

TRAFFIC SIGNAL AND ROADWAY LIGHTING JUNCTION BOX AND CONDUIT DETAILS

COUNTY OF 4-9006.5 ITEM NO. T7 SHEET NO.



MicroStation v8.11.7.443 E-SHEET NAME: T00900SP USER: charles.weitzel DATE PLOTTED: January 22, 2019 FILE NAME: C:\USERS\CHARLES.WEITZEL\DESKTOP\4-9006\TUESDAY\T00900SP.DGN

3/10/2017

### CONDUIT INSTALLATION IN EX. CABINET BASE

CONDUIT MAY BE INSTALLED BY SAWING A SLOT AND CHIPPING OUT THE BASE OR DRILLING A HOLE AND CHIPPING OUT THE CONDUIT AND BASE. THE SPACE BETWEEN THE CONDUIT AND BASE WITH GROUT AFTER CONDUIT IS INSTALLED.

### CONDUIT INSTALLATION IN EX. POLE BASE

INSTALL ELBOW OR BEND CONDUIT, INSTALL BASE COPPER TO EX. GROUND LUG IN POLE.

### OPEN CUT PAVEMENT DETAIL

1/2" ASPHALT SURFACE COMPACTED IF NEEDED  
SAM CUT  
CLASS A CONCRETE  
SCHEDULE 80 PVC CONDUIT  
UNDISTURBED EARTH

1/2" MIN  
3" MIN  
24" MIN  
3" MIN  
6" MIN  
6" MIN

1/2" BASE @ 12" O.C. EACH WAY OR  
#4 BARS @ 6" O.C. EACH WAY  
#4 BARS @ 6" O.C. EACH WAY

CONDUIT INSTALLATIONS IN EXISTING LOCATIONS

COUNTY OF	ITEM NO.	SHEET NO.
	4-9006.5	79

MicroStation v8.11.7.443 E-SHEET NAME: T01005G USER: charles.weitzel DATE PLOTTED: January 22, 2019 FILE NAME: C:\USERS\CHARLES.WEITZEL\DESKTOP\4-8006\TUESDAY101005G.DGN

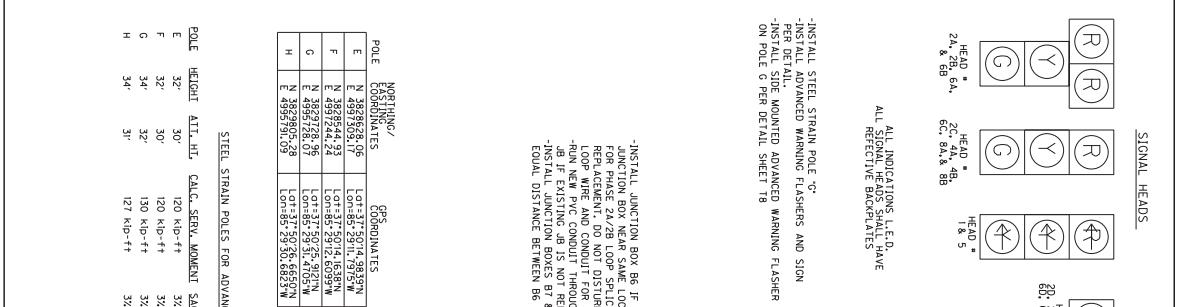

ALL NEW SIGNAL HEADS SHALL BE BETWEEN 17'-10" FROM THE BOTTOM OF THE SIGNAL HEAD TO THE FINISHED PAVEMENT. IF RASTING/NUMBER OF SPAN IS NEEDED, THIS WILL BE INCIDENTAL TO MESSAGEBARS 10,800 LB

ALL INDICATORS L.E.D. ALL SIGNAL HEADS SHALL HAVE REFLECTIVE BACKPLATES

INSTALL STEEL STRAIN POLE 'C' PER DETAIL C MOUNTED ADVANCED WARNING FLASHER ON POLE C PER DETAIL SHEET 18

INSTALL JUNCTION BOX B6 IF EXISTING FOR PHASE 2A/2B LOOP SPLICE IS IN NEED OF LOOP WIRE AND CONDUIT THROUGH EXISTING RUN NEW PVC CONDUIT THROUGH EXISTING

JB IF EXISTING JB IS NOT REPLACED

INSTALL JUNCTION BOXES B1 & B8 AT SIGNAL D/S SIDE BETWEEN B6 AND AMF

INSTALL TYPE ATC CONTROLLER IN MODEL 332 BASE MOUNT CABLING CONDUIT FROM CONTROLLER TO EXISTING POLE 'A' -INSTALL SUPPLEMENTAL HEAD 2C ON EX POLE 'A'

INSTALL JUNCTION BOX B7 IF EXISTING FOR PHASE 5 LOOP SPLICE IS IN NEED OF LOOP WIRE AND CONDUIT THROUGH EXISTING RUN NEW PVC CONDUIT THROUGH EXISTING

JB IF EXISTING JB IS NOT REPLACED

INSTALL ROUTING ON CABINET AS SHOWN ON THE SPECIFICATION SHEETS

LOCATE EXISTING 14/1 TO LOOP WIRE SPLIT FOR PHASE 8, NEW 14/1 TO EXISTING LOOP WIRE SHALL BE PLACED POLE B OR JUNCTION BOX, INSTALL NEW JUNCTION BOX AND CONDUIT IF NEEDED.

LOCATE EXISTING 14/1 TO LOOP WIRE SPLIT FOR PHASE 4, NEW 14/1 TO EXISTING LOOP WIRE SHALL BE PLACED POLE B OR JUNCTION BOX, INSTALL NEW JUNCTION BOX AND CONDUIT IF NEEDED.

STEEL STRAIN POLES FOR ADVANCED WARNING FLASHERS

POLE EASTING	NORTHING	DATE	DESCRIPTION
E 2392828.06	N 4382828.06	10/13/17	50'x14'x14'x14'
F 2392828.06	N 4382828.06	10/13/17	50'x14'x14'x14'
G 2392828.06	N 4382828.06	10/13/17	50'x14'x14'x14'
H 2392828.06	N 4382828.06	10/13/17	50'x14'x14'x14'

EXISTING LOOP SCHEDULE

LOOP	PHASE	SPLIT	CHANNEL	SIZE	TURNS	DIST. FROM STOP BAR
1	2A	1	1	1	1	1
2	12	1	1	1	1	1
3	12	1	1	1	1	1
4	16	1	1	1	1	1
5	J1	1	1	1	1	1
6	J2	1	1	1	1	1
8	J2	1	1	1	1	1
9	J2	1	1	1	1	1

WIRING SCHEDULE

ORIGIN	ENDING	CONNECTING
SH 2A	SH 2A & 2B	SH 2A & 2B
SH 4A	SH 4A & 4B	SH 4A & 4B
SH 5	SH 5	SH 5
SH 6A	SH 6A & 6B	SH 6A & 6B
SH 8A	SH 8A & 8B	SH 8A & 8B
SH 2C	SH 2C	SH 2C
SH 6C	SH 6C	SH 6C
SH 6B	SH 6B	SH 6B
SH 2C	SH 2C	SH 2C
SH 2C	SH 2C	SH 2C
SH 2C	SH 2C	SH 2C
SH 6D	SH 6D & 6E	SH 6D & 6E
SH 6E	SH 6E & 6G	SH 6E & 6G

INSTALL SUPPLEMENTAL HEAD 6C ON EX POLE C

INSTALL STEEL STRAIN POLE 'E'

INSTALL ADVANCED WARNING FLASHERS AND SIGN

INSTALL SIDE MOUNTED ADVANCED WARNING FLASHER ON POLE E PER DETAIL SHEET 18

INSTALL STEEL STRAIN POLE 'F'

INSTALL ADVANCED WARNING FLASHERS AND SIGN

INSTALL SIDE MOUNTED ADVANCED WARNING FLASHER ON POLE F PER DETAIL SHEET 18

INSTALL STEEL STRAIN POLE 'G'

INSTALL ADVANCED WARNING FLASHERS AND SIGN

INSTALL SIDE MOUNTED ADVANCED WARNING FLASHER ON POLE G PER DETAIL SHEET 18

INSTALL STEEL STRAIN POLE 'H'

INSTALL ADVANCED WARNING FLASHERS AND SIGN

INSTALL SIDE MOUNTED ADVANCED WARNING FLASHER ON POLE H PER DETAIL SHEET 18

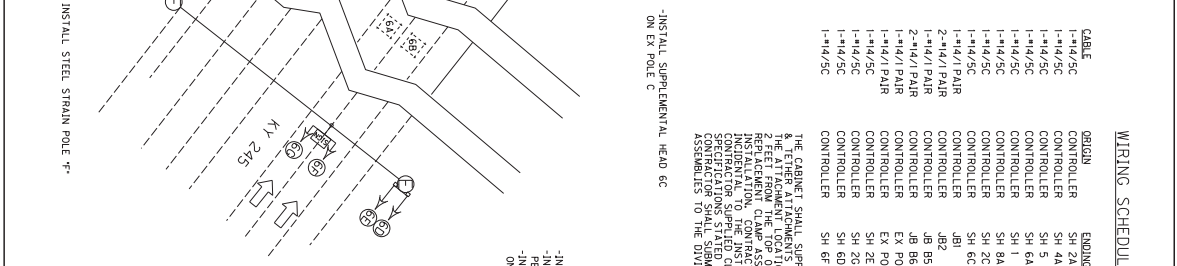

TRAFFIC SIGNAL PLAN SHEET  
KY 245 @ KY 1430 NELSON COUNTY

SCALE 1" = 20'

LEGEND

- BASE MOUNTED CONTROLLER
- EXISTING STEEL STRAIN POLE
- JUNCTION BOXES (AS DESIGNATED)
- SIGNAL HEAD
- POLE MOUNTED ADVANCED WARNING FLASHER ASSEMBLY
- OVERHEAD ADVANCED WARNING FLASHER ASSEMBLY
- EXISTING LOOP DETECTOR
- 2" PVC SCHEDULE 90 (UNLESS OTHERWISE NOTED)

MicroStation v8.11.7.443 E-SHEET NAME: T011005G USER: charles.weitzel DATE PLOTTED: January 1, 0001 FILE NAME: C:\USERS\CHARLES.WEITZEL\DESKTOP4-0006\TUESDAY011005G.DGN

**WIRING SCHEDULE**

CABLE	ORIGIN	ENDING	CONNECTING
1-1/4"/5C	CONTROLLER	SH 2B	SH 2A & 2B
1-1/4"/5C	CONTROLLER	SH 4C	SH 4A & 4B & 4C
1-1/4"/5C	CONTROLLER	SH 5	SH 5
1-1/4"/5C	CONTROLLER	SH 6A	SH 6A & 6B
1-1/4"/5C	CONTROLLER	SH 1	SH 1 & 8B & 8C
1-1/4"/5C	CONTROLLER	SH 8A	SH 8A
1-1/4"/5C	CONTROLLER	SH 6C	SH 2C
2-1/4"/1 PAIR	CONTROLLER	JB1	LOOPS 2A & 2B
2-1/4"/1 PAIR	CONTROLLER	EX POLE C	EXISTING LOOPS 4A & 4B
2-1/4"/1 PAIR	CONTROLLER	EX JB B3	EXISTING LOOPS 8A, 2A, 2 DET
2-1/4"/5C	CONTROLLER	POLE A	EX PED HEADS 8A/2A, 2 DET
2-1/4"/5C	CONTROLLER	EX POLE B	EX PED HEADS 2B/4B, 2 DET
2-1/4"/5C	CONTROLLER	EX POLE C	EX PED HEADS 4A/6A, 2 DET
1-1/4"/1 PAIR	CONTROLLER	EX POLE D	EX PED HEADS 6A/8A, 2 DET
1-1/4"/1 PAIR	CONTROLLER	SEE NOTE	EXISTING LOOP 5
1-1/4"/1 PAIR	CONTROLLER	POLE A	EXISTING LOOP 1

**LOOP SCHEDULE**

LOOP	PHASE	SLOT	CHANNEL	SIZE	TURNS	DIST. FROM
2A	2	12	1	6X6	3	75'
2B	2	12	2	6X6	3	75'
6A	6	J2	1	6X6	3	75'
6B	6	J2	2	6X6	3	75'
8B	8	J6	1	1	1	1
8C	8	J6	2	1	1	1
8D	8	J6	3	1	1	1
8E	8	J6	4	1	1	1
8F	8	J6	5	1	1	1
8G	8	J6	6	1	1	1
8H	8	J6	7	1	1	1
8I	8	J6	8	1	1	1
8J	8	J6	9	1	1	1
8K	8	J6	10	1	1	1
8L	8	J6	11	1	1	1
8M	8	J6	12	1	1	1
8N	8	J6	13	1	1	1
8O	8	J6	14	1	1	1
8P	8	J6	15	1	1	1
8Q	8	J6	16	1	1	1
8R	8	J6	17	1	1	1
8S	8	J6	18	1	1	1
8T	8	J6	19	1	1	1
8U	8	J6	20	1	1	1
8V	8	J6	21	1	1	1
8W	8	J6	22	1	1	1
8X	8	J6	23	1	1	1
8Y	8	J6	24	1	1	1
8Z	8	J6	25	1	1	1

**STEEL STRAIN POLES**

POLE	HEIGHT	SPAN	ALT. ALT.	CALC. SERV. MOMENT	SAG
A	30'	A-B	27.5'	131 KIP-FT	5%
B	28.5'	A-D	28.5'		5%
C	28'	B-A	28'		5%
D	28.5'	D-A	28.5'		5%

**FLASHING YELLOW ARROW SIGNAL WIRING AND SPECIAL REQUIREMENTS**

3-CONDUCTOR EQUIP-TERMINATED HEADS  
 CONNECTION COLOR OUTPUT FILE CONNECTION COLOR ON PHASE  
 RED ARROW RED PHASE 1 RED  
 FLASHING YELLOW ARROW ORANGE PHASE 1 YELLOW  
 GREEN ARROW BLACK PHASE 1 GREEN  
 NEUTRAL WHITE PHASE 1 WHITE  
 PHASE 2 GREEN PHASE 2 GREEN  
 PHASE 2 YELLOW PHASE 2 YELLOW  
 PHASE 2 WHITE PHASE 2 WHITE

THE CONTRACTOR SHALL CONNECT THE CONNECTOR LABELED 2PBY 4PBY 6PBY 8PBY TO THE CONNECTOR LABELED 1A, 1B, 1C, 1D, 1E, 1F, 1G, 1H, 1I, 1J, 1K, 1L, 1M, 1N, 1O, 1P, 1Q, 1R, 1S, 1T, 1U, 1V, 1W, 1X, 1Y, 1Z, 2A, 2B, 2C, 2D, 2E, 2F, 2G, 2H, 2I, 2J, 2K, 2L, 2M, 2N, 2O, 2P, 2Q, 2R, 2S, 2T, 2U, 2V, 2W, 2X, 2Y, 2Z, 3A, 3B, 3C, 3D, 3E, 3F, 3G, 3H, 3I, 3J, 3K, 3L, 3M, 3N, 3O, 3P, 3Q, 3R, 3S, 3T, 3U, 3V, 3W, 3X, 3Y, 3Z, 4A, 4B, 4C, 4D, 4E, 4F, 4G, 4H, 4I, 4J, 4K, 4L, 4M, 4N, 4O, 4P, 4Q, 4R, 4S, 4T, 4U, 4V, 4W, 4X, 4Y, 4Z, 5A, 5B, 5C, 5D, 5E, 5F, 5G, 5H, 5I, 5J, 5K, 5L, 5M, 5N, 5O, 5P, 5Q, 5R, 5S, 5T, 5U, 5V, 5W, 5X, 5Y, 5Z, 6A, 6B, 6C, 6D, 6E, 6F, 6G, 6H, 6I, 6J, 6K, 6L, 6M, 6N, 6O, 6P, 6Q, 6R, 6S, 6T, 6U, 6V, 6W, 6X, 6Y, 6Z, 7A, 7B, 7C, 7D, 7E, 7F, 7G, 7H, 7I, 7J, 7K, 7L, 7M, 7N, 7O, 7P, 7Q, 7R, 7S, 7T, 7U, 7V, 7W, 7X, 7Y, 7Z, 8A, 8B, 8C, 8D, 8E, 8F, 8G, 8H, 8I, 8J, 8K, 8L, 8M, 8N, 8O, 8P, 8Q, 8R, 8S, 8T, 8U, 8V, 8W, 8X, 8Y, 8Z, 9A, 9B, 9C, 9D, 9E, 9F, 9G, 9H, 9I, 9J, 9K, 9L, 9M, 9N, 9O, 9P, 9Q, 9R, 9S, 9T, 9U, 9V, 9W, 9X, 9Y, 9Z, 10A, 10B, 10C, 10D, 10E, 10F, 10G, 10H, 10I, 10J, 10K, 10L, 10M, 10N, 10O, 10P, 10Q, 10R, 10S, 10T, 10U, 10V, 10W, 10X, 10Y, 10Z, 11A, 11B, 11C, 11D, 11E, 11F, 11G, 11H, 11I, 11J, 11K, 11L, 11M, 11N, 11O, 11P, 11Q, 11R, 11S, 11T, 11U, 11V, 11W, 11X, 11Y, 11Z, 12A, 12B, 12C, 12D, 12E, 12F, 12G, 12H, 12I, 12J, 12K, 12L, 12M, 12N, 12O, 12P, 12Q, 12R, 12S, 12T, 12U, 12V, 12W, 12X, 12Y, 12Z, 13A, 13B, 13C, 13D, 13E, 13F, 13G, 13H, 13I, 13J, 13K, 13L, 13M, 13N, 13O, 13P, 13Q, 13R, 13S, 13T, 13U, 13V, 13W, 13X, 13Y, 13Z, 14A, 14B, 14C, 14D, 14E, 14F, 14G, 14H, 14I, 14J, 14K, 14L, 14M, 14N, 14O, 14P, 14Q, 14R, 14S, 14T, 14U, 14V, 14W, 14X, 14Y, 14Z, 15A, 15B, 15C, 15D, 15E, 15F, 15G, 15H, 15I, 15J, 15K, 15L, 15M, 15N, 15O, 15P, 15Q, 15R, 15S, 15T, 15U, 15V, 15W, 15X, 15Y, 15Z, 16A, 16B, 16C, 16D, 16E, 16F, 16G, 16H, 16I, 16J, 16K, 16L, 16M, 16N, 16O, 16P, 16Q, 16R, 16S, 16T, 16U, 16V, 16W, 16X, 16Y, 16Z, 17A, 17B, 17C, 17D, 17E, 17F, 17G, 17H, 17I, 17J, 17K, 17L, 17M, 17N, 17O, 17P, 17Q, 17R, 17S, 17T, 17U, 17V, 17W, 17X, 17Y, 17Z, 18A, 18B, 18C, 18D, 18E, 18F, 18G, 18H, 18I, 18J, 18K, 18L, 18M, 18N, 18O, 18P, 18Q, 18R, 18S, 18T, 18U, 18V, 18W, 18X, 18Y, 18Z, 19A, 19B, 19C, 19D, 19E, 19F, 19G, 19H, 19I, 19J, 19K, 19L, 19M, 19N, 19O, 19P, 19Q, 19R, 19S, 19T, 19U, 19V, 19W, 19X, 19Y, 19Z, 20A, 20B, 20C, 20D, 20E, 20F, 20G, 20H, 20I, 20J, 20K, 20L, 20M, 20N, 20O, 20P, 20Q, 20R, 20S, 20T, 20U, 20V, 20W, 20X, 20Y, 20Z, 21A, 21B, 21C, 21D, 21E, 21F, 21G, 21H, 21I, 21J, 21K, 21L, 21M, 21N, 21O, 21P, 21Q, 21R, 21S, 21T, 21U, 21V, 21W, 21X, 21Y, 21Z, 22A, 22B, 22C, 22D, 22E, 22F, 22G, 22H, 22I, 22J, 22K, 22L, 22M, 22N, 22O, 22P, 22Q, 22R, 22S, 22T, 22U, 22V, 22W, 22X, 22Y, 22Z, 23A, 23B, 23C, 23D, 23E, 23F, 23G, 23H, 23I, 23J, 23K, 23L, 23M, 23N, 23O, 23P, 23Q, 23R, 23S, 23T, 23U, 23V, 23W, 23X, 23Y, 23Z, 24A, 24B, 24C, 24D, 24E, 24F, 24G, 24H, 24I, 24J, 24K, 24L, 24M, 24N, 24O, 24P, 24Q, 24R, 24S, 24T, 24U, 24V, 24W, 24X, 24Y, 24Z, 25A, 25B, 25C, 25D, 25E, 25F, 25G, 25H, 25I, 25J, 25K, 25L, 25M, 25N, 25O, 25P, 25Q, 25R, 25S, 25T, 25U, 25V, 25W, 25X, 25Y, 25Z, 26A, 26B, 26C, 26D, 26E, 26F, 26G, 26H, 26I, 26J, 26K, 26L, 26M, 26N, 26O, 26P, 26Q, 26R, 26S, 26T, 26U, 26V, 26W, 26X, 26Y, 26Z, 27A, 27B, 27C, 27D, 27E, 27F, 27G, 27H, 27I, 27J, 27K, 27L, 27M, 27N, 27O, 27P, 27Q, 27R, 27S, 27T, 27U, 27V, 27W, 27X, 27Y, 27Z, 28A, 28B, 28C, 28D, 28E, 28F, 28G, 28H, 28I, 28J, 28K, 28L, 28M, 28N, 28O, 28P, 28Q, 28R, 28S, 28T, 28U, 28V, 28W, 28X, 28Y, 28Z, 29A, 29B, 29C, 29D, 29E, 29F, 29G, 29H, 29I, 29J, 29K, 29L, 29M, 29N, 29O, 29P, 29Q, 29R, 29S, 29T, 29U, 29V, 29W, 29X, 29Y, 29Z, 30A, 30B, 30C, 30D, 30E, 30F, 30G, 30H, 30I, 30J, 30K, 30L, 30M, 30N, 30O, 30P, 30Q, 30R, 30S, 30T, 30U, 30V, 30W, 30X, 30Y, 30Z, 31A, 31B, 31C, 31D, 31E, 31F, 31G, 31H, 31I, 31J, 31K, 31L, 31M, 31N, 31O, 31P, 31Q, 31R, 31S, 31T, 31U, 31V, 31W, 31X, 31Y, 31Z, 32A, 32B, 32C, 32D, 32E, 32F, 32G, 32H, 32I, 32J, 32K, 32L, 32M, 32N, 32O, 32P, 32Q, 32R, 32S, 32T, 32U, 32V, 32W, 32X, 32Y, 32Z, 33A, 33B, 33C, 33D, 33E, 33F, 33G, 33H, 33I, 33J, 33K, 33L, 33M, 33N, 33O, 33P, 33Q, 33R, 33S, 33T, 33U, 33V, 33W, 33X, 33Y, 33Z, 34A, 34B, 34C, 34D, 34E, 34F, 34G, 34H, 34I, 34J, 34K, 34L, 34M, 34N, 34O, 34P, 34Q, 34R, 34S, 34T, 34U, 34V, 34W, 34X, 34Y, 34Z, 35A, 35B, 35C, 35D, 35E, 35F, 35G, 35H, 35I, 35J, 35K, 35L, 35M, 35N, 35O, 35P, 35Q, 35R, 35S, 35T, 35U, 35V, 35W, 35X, 35Y, 35Z, 36A, 36B, 36C, 36D, 36E, 36F, 36G, 36H, 36I, 36J, 36K, 36L, 36M, 36N, 36O, 36P, 36Q, 36R, 36S, 36T, 36U, 36V, 36W, 36X, 36Y, 36Z, 37A, 37B, 37C, 37D, 37E, 37F, 37G, 37H, 37I, 37J, 37K, 37L, 37M, 37N, 37O, 37P, 37Q, 37R, 37S, 37T, 37U, 37V, 37W, 37X, 37Y, 37Z, 38A, 38B, 38C, 38D, 38E, 38F, 38G, 38H, 38I, 38J, 38K, 38L, 38M, 38N, 38O, 38P, 38Q, 38R, 38S, 38T, 38U, 38V, 38W, 38X, 38Y, 38Z, 39A, 39B, 39C, 39D, 39E, 39F, 39G, 39H, 39I, 39J, 39K, 39L, 39M, 39N, 39O, 39P, 39Q, 39R, 39S, 39T, 39U, 39V, 39W, 39X, 39Y, 39Z, 40A, 40B, 40C, 40D, 40E, 40F, 40G, 40H, 40I, 40J, 40K, 40L, 40M, 40N, 40O, 40P, 40Q, 40R, 40S, 40T, 40U, 40V, 40W, 40X, 40Y, 40Z, 41A, 41B, 41C, 41D, 41E, 41F, 41G, 41H, 41I, 41J, 41K, 41L, 41M, 41N, 41O, 41P, 41Q, 41R, 41S, 41T, 41U, 41V, 41W, 41X, 41Y, 41Z, 42A, 42B, 42C, 42D, 42E, 42F, 42G, 42H, 42I, 42J, 42K, 42L, 42M, 42N, 42O, 42P, 42Q, 42R, 42S, 42T, 42U, 42V, 42W, 42X, 42Y, 42Z, 43A, 43B, 43C, 43D, 43E, 43F, 43G, 43H, 43I, 43J, 43K, 43L, 43M, 43N, 43O, 43P, 43Q, 43R, 43S, 43T, 43U, 43V, 43W, 43X, 43Y, 43Z, 44A, 44B, 44C, 44D, 44E, 44F, 44G, 44H, 44I, 44J, 44K, 44L, 44M, 44N, 44O, 44P, 44Q, 44R, 44S, 44T, 44U, 44V, 44W, 44X, 44Y, 44Z, 45A, 45B, 45C, 45D, 45E, 45F, 45G, 45H, 45I, 45J, 45K, 45L, 45M, 45N, 45O, 45P, 45Q, 45R, 45S, 45T, 45U, 45V, 45W, 45X, 45Y, 45Z, 46A, 46B, 46C, 46D, 46E, 46F, 46G, 46H, 46I, 46J, 46K, 46L, 46M, 46N, 46O, 46P, 46Q, 46R, 46S, 46T, 46U, 46V, 46W, 46X, 46Y, 46Z, 47A, 47B, 47C, 47D, 47E, 47F, 47G, 47H, 47I, 47J, 47K, 47L, 47M, 47N, 47O, 47P, 47Q, 47R, 47S, 47T, 47U, 47V, 47W, 47X, 47Y, 47Z, 48A, 48B, 48C, 48D, 48E, 48F, 48G, 48H, 48I, 48J, 48K, 48L, 48M, 48N, 48O, 48P, 48Q, 48R, 48S, 48T, 48U, 48V, 48W, 48X, 48Y, 48Z, 49A, 49B, 49C, 49D, 49E, 49F, 49G, 49H, 49I, 49J, 49K, 49L, 49M, 49N, 49O, 49P, 49Q, 49R, 49S, 49T, 49U, 49V, 49W, 49X, 49Y, 49Z, 50A, 50B, 50C, 50D, 50E, 50F, 50G, 50H, 50I, 50J, 50K, 50L, 50M, 50N, 50O, 50P, 50Q, 50R, 50S, 50T, 50U, 50V, 50W, 50X, 50Y, 50Z, 51A, 51B, 51C, 51D, 51E, 51F, 51G, 51H, 51I, 51J, 51K, 51L, 51M, 51N, 51O, 51P, 51Q, 51R, 51S, 51T, 51U, 51V, 51W, 51X, 51Y, 51Z, 52A, 52B, 52C, 52D, 52E, 52F, 52G, 52H, 52I, 52J, 52K, 52L, 52M, 52N, 52O, 52P, 52Q, 52R, 52S, 52T, 52U, 52V, 52W, 52X, 52Y, 52Z, 53A, 53B, 53C, 53D, 53E, 53F, 53G, 53H, 53I, 53J, 53K, 53L, 53M, 53N, 53O, 53P, 53Q, 53R, 53S, 53T, 53U, 53V, 53W, 53X, 53Y, 53Z, 54A, 54B, 54C, 54D, 54E, 54F, 54G, 54H, 54I, 54J, 54K, 54L, 54M, 54N, 54O, 54P, 54Q, 54R, 54S, 54T, 54U, 54V, 54W, 54X, 54Y, 54Z, 55A, 55B, 55C, 55D, 55E, 55F, 55G, 55H, 55I, 55J, 55K, 55L, 55M, 55N, 55O, 55P, 55Q, 55R, 55S, 55T, 55U, 55V, 55W, 55X, 55Y, 55Z, 56A, 56B, 56C, 56D, 56E, 56F, 56G, 56H, 56I, 56J, 56K, 56L, 56M, 56N, 56O, 56P, 56Q, 56R, 56S, 56T, 56U, 56V, 56W, 56X, 56Y, 56Z, 57A, 57B, 57C, 57D, 57E, 57F, 57G, 57H, 57I, 57J, 57K, 57L, 57M, 57N, 57O, 57P, 57Q, 57R, 57S, 57T, 57U, 57V, 57W, 57X, 57Y, 57Z, 58A, 58B, 58C, 58D, 58E, 58F, 58G, 58H, 58I, 58J, 58K, 58L, 58M, 58N, 58O, 58P, 58Q, 58R, 58S, 58T, 58U, 58V, 58W, 58X, 58Y, 58Z, 59A, 59B, 59C, 59D, 59E, 59F, 59G, 59H, 59I, 59J, 59K, 59L, 59M, 59N, 59O, 59P, 59Q, 59R, 59S, 59T, 59U, 59V, 59W, 59X, 59Y, 59Z, 60A, 60B, 60C, 60D, 60E, 60F, 60G, 60H, 60I, 60J, 60K, 60L, 60M, 60N, 60O, 60P, 60Q, 60R, 60S, 60T, 60U, 60V, 60W, 60X, 60Y, 60Z, 61A, 61B, 61C, 61D, 61E, 61F, 61G, 61H, 61I, 61J, 61K, 61L, 61M, 61N, 61O, 61P, 61Q, 61R, 61S, 61T, 61U, 61V, 61W, 61X, 61Y, 61Z, 62A, 62B, 62C, 62D, 62E, 62F, 62G, 62H, 62I, 62J, 62K, 62L, 62M, 62N, 62O, 62P, 62Q, 62R, 62S, 62T, 62U, 62V, 62W, 62X, 62Y, 62Z, 63A, 63B, 63C, 63D, 63E, 63F, 63G, 63H, 63I, 63J, 63K, 63L, 63M, 63N, 63O, 63P, 63Q, 63R, 63S, 63T, 63U, 63V, 63W, 63X, 63Y, 63Z, 64A, 64B, 64C, 64D, 64E, 64F, 64G, 64H, 64I, 64J, 64K, 64L, 64M, 64N, 64O, 64P, 64Q, 64R, 64S, 64T, 64U, 64V, 64W, 64X, 64Y, 64Z, 65A, 65B, 65C, 65D, 65E, 65F, 65G, 65H, 65I, 65J, 65K, 65L, 65M, 65N, 65O, 65P, 65Q, 65R, 65S, 65T, 65U, 65V, 65W, 65X, 65Y, 65Z, 66A, 66B, 66C, 66D, 66E, 66F, 66G, 66H, 66I, 66J, 66K, 66L, 66M, 66N, 66O, 66P, 66Q, 66R, 66S, 66T, 66U, 66V, 66W, 66X, 66Y, 66Z, 67A, 67B, 67C, 67D, 67E, 67F, 67G, 67H, 67I, 67J, 67K, 67L, 67M, 67N, 67O, 67P, 67Q, 67R, 67S, 67T, 67U, 67V, 67W, 67X, 67Y, 67Z, 68A, 68B, 68C, 68D, 68E, 68F, 68G, 68H, 68I, 68J, 68K, 68L, 68M, 68N, 68O, 68P, 68Q, 68R, 68S, 68T, 68U, 68V, 68W, 68X, 68Y, 68Z, 69A, 69B, 69C, 69D, 69E, 69F, 69G, 69H, 6

## **PART II**

### **SPECIFICATIONS AND STANDARD DRAWINGS**

### **SPECIFICATIONS REFERENCE**

Any reference in the plans or proposal to previous editions of the *Standard Specifications for Road and Bridge Construction* and *Standard Drawings* are superseded by *Standard Specifications for Road and Bridge Construction, Edition of 2012* and *Standard Drawings, Edition of 2016*.

## **SUPPLEMENTAL SPECIFICATIONS**

The contractor shall use the Supplemental Specifications that are effective at the time of letting.  
The Supplemental Specifications can be found at the following link:

<http://transportation.ky.gov/Construction/Pages/Kentucky-Standard-Specifications.aspx>

**2016 STANDARD DRAWINGS THAT APPLY**

---

**ROADWAY**  
**~ *BARRIERS* ~**  
**GUARDRAIL HARDWARE**

DELINEATORS FOR GUARDRAIL.....**SEPIA-032**

**TRAFFIC**  
**~ *TEMPORARY* ~**  
**TRAFFIC CONTROL**

LANE CLOSURE TWO-LANE HIGHWAY .....TTC-100-04  
LANE CLOSURE MULTI-LANE HIGHWAY CASE I .....TTC-115-03  
SHOULDER CLOSURE.....TTC-135-02

COUNTY OF	ITEM NO.	SHEET NO.
-----------	----------	-----------

~ NOTES ~

- BID ITEMS AND UNIT TO BID  
 DELINEATOR FOR GUARDRAIL B/W EACH  
 DELINEATOR FOR GUARDRAIL M/W EACH  
 DELINEATOR FOR GUARDRAIL M/Y EACH
- DELINEATORS SHALL BE MEASURED AND PAID FOR AT THE CONTRACT UNIT PRICE EACH AND SHALL INCLUDE ALL MATERIALS AND LABOR NECESSARY FOR ONE COMPLETE INSTALLATION.
  - DELINEATOR SHAPE AND DIMENSIONS ARE SHOWN FOR ILLUSTRATION PURPOSES ONLY. TYPES OF DELINEATORS PERMITTED SHALL BE FROM THE LIST OF APPROVED MATERIALS.
  - GUARDRAIL DELINEATORS SHALL BE REQUIRED ON ALL GUARDRAIL.
  - DELINEATORS SHALL NOT BE INSTALLED WITHIN THE PAY LIMITS OF THE END TREATMENT.
  - DELINEATORS SHALL BE MANUFACTURED FROM 12 GA. GALVANIZED STEEL.
  - DIMENSIONS SHOWN ARE APPROXIMATE AND ARE SUBJECT TO MANUFACTURER'S TOLERANCES.
  - WHEN CONCRETE BARRIERS EXTEND ACROSS BRIDGE STRUCTURES IN LIEU OF STEEL BEAM GUARDRAIL, DELINEATORS SHALL BE INSTALLED AT SAME VERTICAL ALIGNMENT AS ON THE GUARDRAIL, AND DELINEATORS SHALL COMPLY WITH CURRENT STANDARD DRAWING RBM-020.
  - DELINEATORS SHALL BE INSTALLED IN ACCORDANCE WITH MANUFACTURER'S RECOMMENDATIONS.

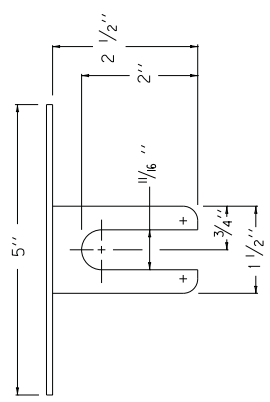

PLAN VIEW

TYPE IX SHEETING,  
 YELLOW OR WHITE

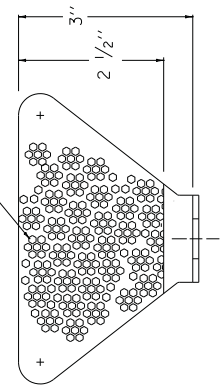

FRONT VIEW

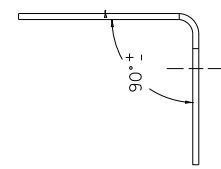

SIDE VIEW

DIMENSIONS SHOWN ARE FOR ONE VERSION OF A WEB-MOUNTED GUARDRAIL DELINEATOR. DELINEATORS WITH ALTERNATE DIMENSIONS MAY BE CONSIDERED FOR INCLUSION ON THE APPROVED PRODUCTS LIST.

BI-DIRECTIONAL WHITE DELINEATOR FOR GUARDRAIL FACING TRAFFIC

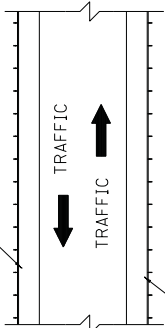

BI-DIRECTIONAL WHITE DELINEATOR FOR GUARDRAIL FACING TRAFFIC

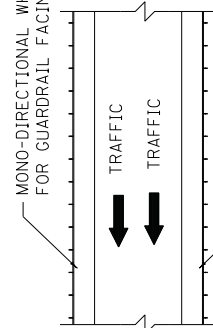

MONO-DIRECTIONAL WHITE DELINEATOR FOR GUARDRAIL FACING TRAFFIC

MONO-DIRECTIONAL YELLOW DELINEATOR FOR GUARDRAIL FACING TRAFFIC



PLACEMENT OF DELINEATORS FOR GUARDRAIL

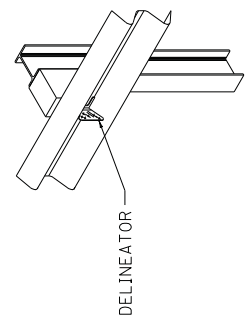

ISOMETRIC VIEW

USE WITH CUR. STD. DWGS.  
 RBM-020, RBR-060

APPROXIMATE DELINEATOR SPACING	
TANGENT	100'
CURVE	50'

SPACING SHOULD BE ADJUSTED IN CURVES SO THAT SEVERAL DELINEATORS ARE ALWAYS SIMULTANEOUSLY VISIBLE TO THE ROAD USER.

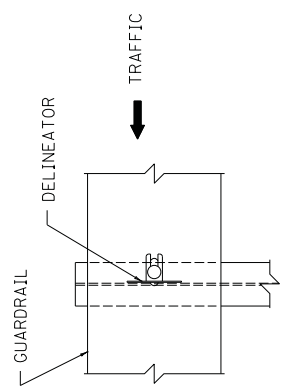

FRONT VIEW

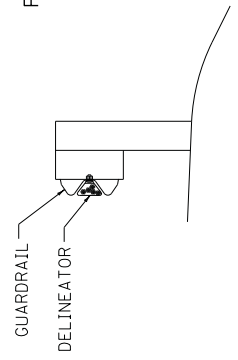

SIDE VIEW

KENTUCKY  
 DEPARTMENT OF HIGHWAYS  
 DELINEATORS FOR GUARDRAIL

DATE: 11-17-17  
 SUBMITTED BY: [Signature]  
 DIRECTOR/DESIGNER OF DESIGN: [Signature]

032



COUNTY OF	ITEM NO.	SHEET NO.

Single turn lane

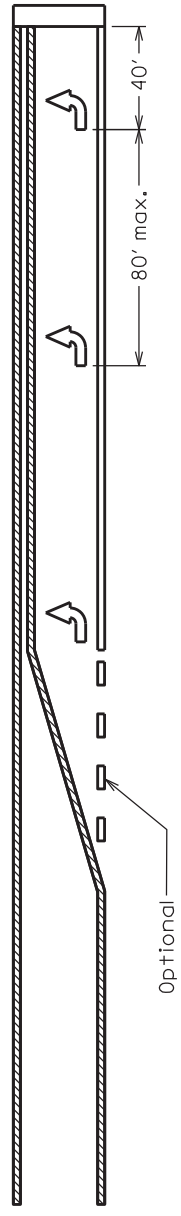

Dual turn lane

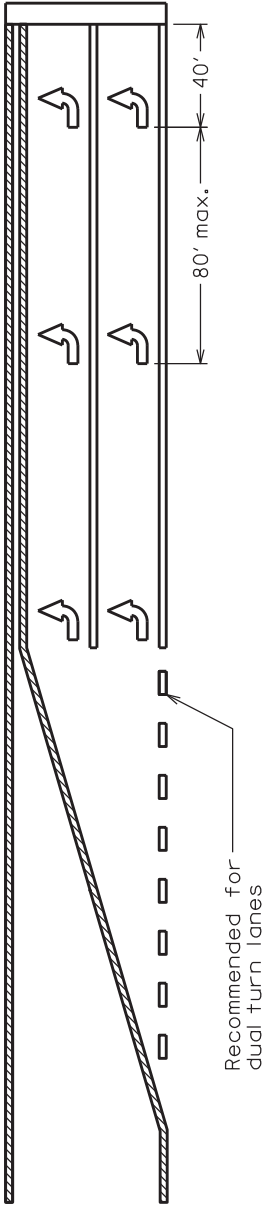

Offset turn lane

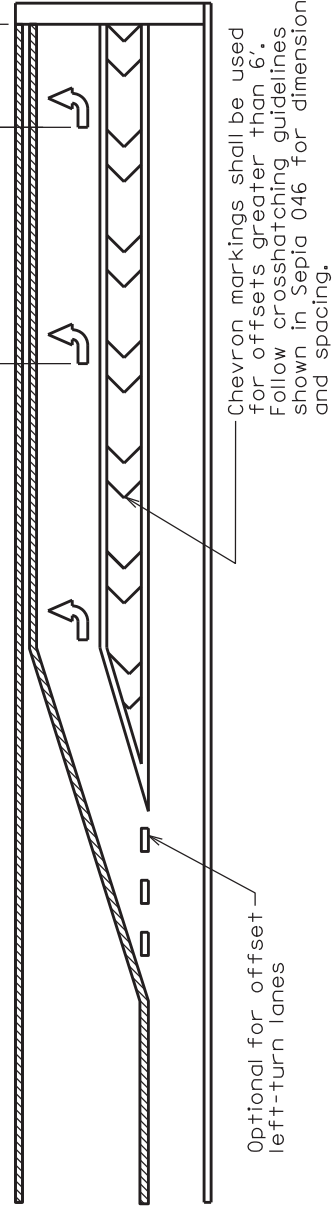

**STRIPING NOTES:**

- ARROWS SHALL BE USED IN ANY EXCLUSIVE TURN LANES.
- IN A SINGLE TURN LANE, DOTTED WHITE LINE EXTENSIONS MAY BE USED THROUGH THE TAPER OF THE TURN LANE.
- IF USED, DOTTED WHITE LANE LINE EXTENSIONS SHALL BE NORMAL WIDTH, AND SHOULD BE 2' LONG, WITH A GAP OF 2-6' BETWEEN EACH LINE.
- IN DUAL TURN LANES, DOTTED WHITE LANE LINE EXTENSIONS SHOULD BE USED THROUGH THE TAPER OF THE TURN LANE. BOTH SOLID LINES FORMING THE TURN LANES SHALL BEGIN AT THE DOWNSTREAM END OF THE TAPER.

**ARROW SPACING NOTES:**

- IN SINGLE-DIRECTION TURN LANES, ARROWS SHOULD BE SPACED AS FOLLOWS:
- AT LEAST TWO ARROWS SHOULD BE USED IN EACH TURN LANE. HOWEVER, IF A TURN LANE IS LESS THAN 80' IN LENGTH, THE DOWNSTREAM ARROW MAY BE ELIMINATED.
- THE FIRST UPSTREAM ARROW SHALL BE PLACED AT THE BEGINNING OF THE SOLID LINE FOR THE TURN LANE.
- THE LAST DOWNSTREAM ARROW SHOULD BE PLACED 40' FROM THE STOP BAR.
- ANY ADDITIONAL ARROWS SHOULD BE EVENLY SPACED. SPACING SHOULD NOT EXCEED 80'.
- ARROW SPACING AND NUMBER OF ARROWS MAY VARY BASED ON SITE CONDITIONS.

**DOTTED EXTENSION DIMENSIONS:**



Dotted extensions shall be normal width.

**KENTUCKY DEPARTMENT OF HIGHWAYS**

**TYPICAL MARKINGS FOR TURN LANES**

SUBMITTED: *R. [Signature]* DATE: 11-30-18

042

**DRAWING NOT TO SCALE**

**LEGEND**

MARKINGS	WHITE
	YELLOW

Chevron markings shall be used for offsets greater than 6'. Follow crosshatching guidelines shown in Sepia 046 for dimensions and spacing.

Optional for offset left-turn lanes

COUNTY OF	ITEM NO.	SHEET NO.

LANE\_DROP\_MARKINGS\_NOTES:

IN SITUATIONS WHERE A THROUGH LANE BECOMES A MANDATORY TURN LANE, THE FOLLOWING GUIDELINES APPLY:  
 -A WIDE SOLID LINE SHOULD EXTEND BACK A MINIMUM OF 200' FROM THE STOP BAR.  
 -A WIDE, DOTTED LINE SHALL EXTEND FROM THE END OF THE SOLID LINE BACK A MINIMUM OF THE DISTANCE SHOWN IN THE CHART (A). THESE LINES SHALL BE 3' LONG, WITH A SPACE OF 9' BETWEEN LINES.  
 -ALTERNATING ARROWS AND "ONLY" WORD MESSAGES SHALL BE USED, WITH THE FIRST AND LAST MARKING BEING AN ARROW.  
 -ALTERNATING ARROWS AND "ONLY" WORD MESSAGES SHOULD BE SPACED EVENLY, FOLLOWING GUIDELINES FOR ARROW SPACING. THESE SYMBOLS SHALL EXTEND BACK AT LEAST TO THE END OF THE SOLID STRIPE, BUT MAY BE EXTENDED BACK FARTHER IF ADDITIONAL GUIDANCE IS NEEDED.

Lane\_drop\_scenario

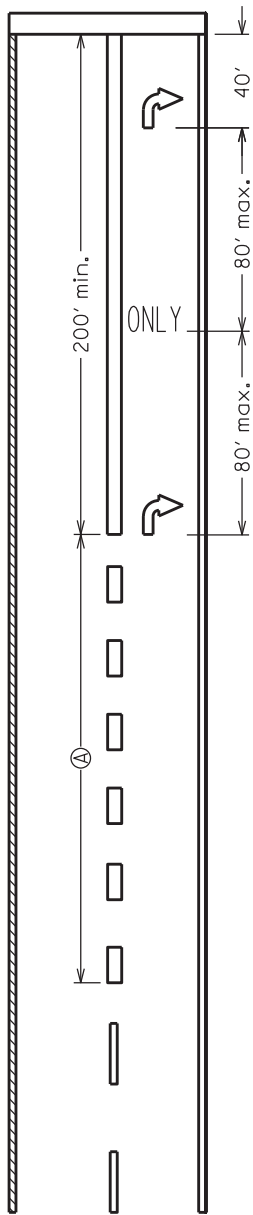

Speed Limit	(A)
25	125'
35	245'
45	540'
55	660'
65	780'

WIDE\_DOTTED\_LANE\_LINE\_DIMENSIONS:

3' → | ← 9'

Dotted lane lines shall be twice the normal width in lane drop scenarios.

TWO-WAY LEFT-TURN LANE NOTES:

IN A TWO-WAY LEFT-TURN LANE, THE FOLLOWING GUIDELINES APPLY:  
 -ONE SET OF ARROWS SHOULD BE PLACED AT OR NEAR THE BEGINNING OF THE TWO-WAY LEFT-TURN LANE.  
 -ADDITIONAL SETS OF ARROWS SHOULD BE PLACED THROUGHOUT THE TWO-WAY LEFT-TURN LANE IF LEFT TURN MOVEMENTS ARE EXPECTED. THEY SHOULD BE SPACED NO LESS THAN 300' AND NO MORE THAN 1/2 MILE.  
 -THE SPACING BETWEEN EACH ARROW IN A SINGLE ARROW SET SHOULD BE 16 FEET.  
 -TWO-WAY LEFT-TURN LANES SHALL TERMINATE IN A DEDICATED LEFT-TURN LANE AT A SIGNALIZED INTERSECTION. THEY MAY TERMINATE IN A DEDICATED LEFT-TURN LANE AT OTHER LOCATIONS IF DEEMED NECESSARY.  
 -CONTACT TRAFFIC ENGINEER FOR RECOMMENDED DISTANCE FOR LEFT TURN STORAGE AT INTERSECTIONS.  
 -REFER TO THE TRAFFIC OPERATIONS GUIDANCE MANUAL SECTION TO-504 FOR MORE GUIDANCE ON TWO-WAY LEFT-TURN LANES.

Two-way\_left-turn\_lane

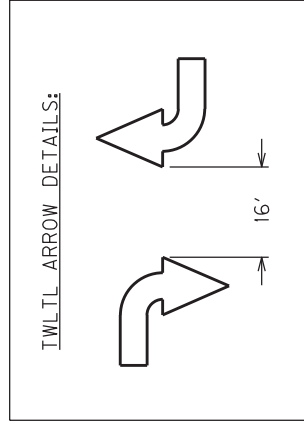
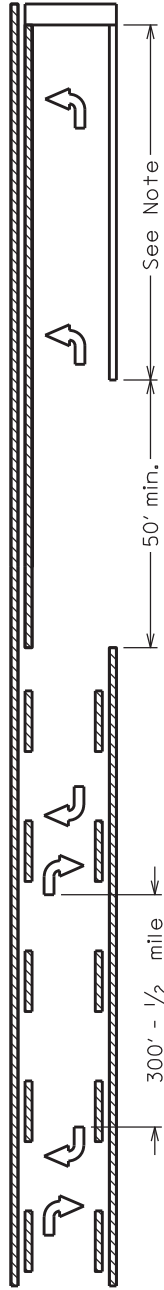

**DRAWING NOT TO SCALE**

LEGEND	
MARKINGS	WHITE
	YELLOW

**KENTUCKY DEPARTMENT OF HIGHWAYS**

**TYPICAL MARKINGS FOR TURN LANES**

SUBMITTED: *R. [Signature]* DATE: 11-30-18

043

SHEET NO.	ITEM NO.	COUNTY OF
-----------	----------	-----------

CROSSWALK DETAIL

"TRANSVERSE"

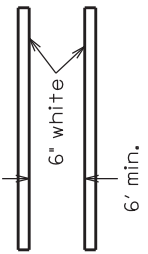

TRANSVERSE LINES SHOULD EXTEND ACROSS THE FULL WIDTH OF THE APPROACH PAVEMENT.

TRANSVERSE LINES MAY BE COMBINED WITH LONGITUDINAL LINES TO FORM A "LADDER-STYLE" CROSSWALK.

"LONGITUDINAL"

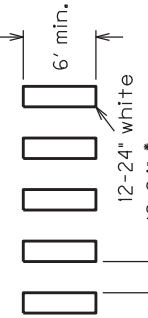

CROSSWALK BARS SHALL BE INSTALLED PARALLEL WITH ONCOMING TRAFFIC.

\*SPACING OF BARS SHOULD BE MODIFIED SO AS TO AVOID TIRE PATHS OF APPROACHING VEHICLES.

STOP LINE NOTES

1. STOP LINES SHALL BE 24" WHITE AND SHALL EXTEND ACROSS ALL APPROACH LANES.
2. STOP LINES SHOULD BE PLACED A MINIMUM OF 4' IN ADVANCE OF THE NEAREST EDGE OF A MARKED CROSSWALK. IN THE ABSENCE OF A MARKED CROSSWALK, STOP LINES SHOULD BE PLACED NO MORE THAN 30' OR NO LESS THAN 4' FROM THE NEAREST EDGE OF THE INTERSECTING ROADWAY.
3. STOP LINES IN LEFT TURN LANES MAY BE PULLED BACK SO AS NOT TO INTERFERE WITH THE WHEEL PATH OF TURNING VEHICLES.

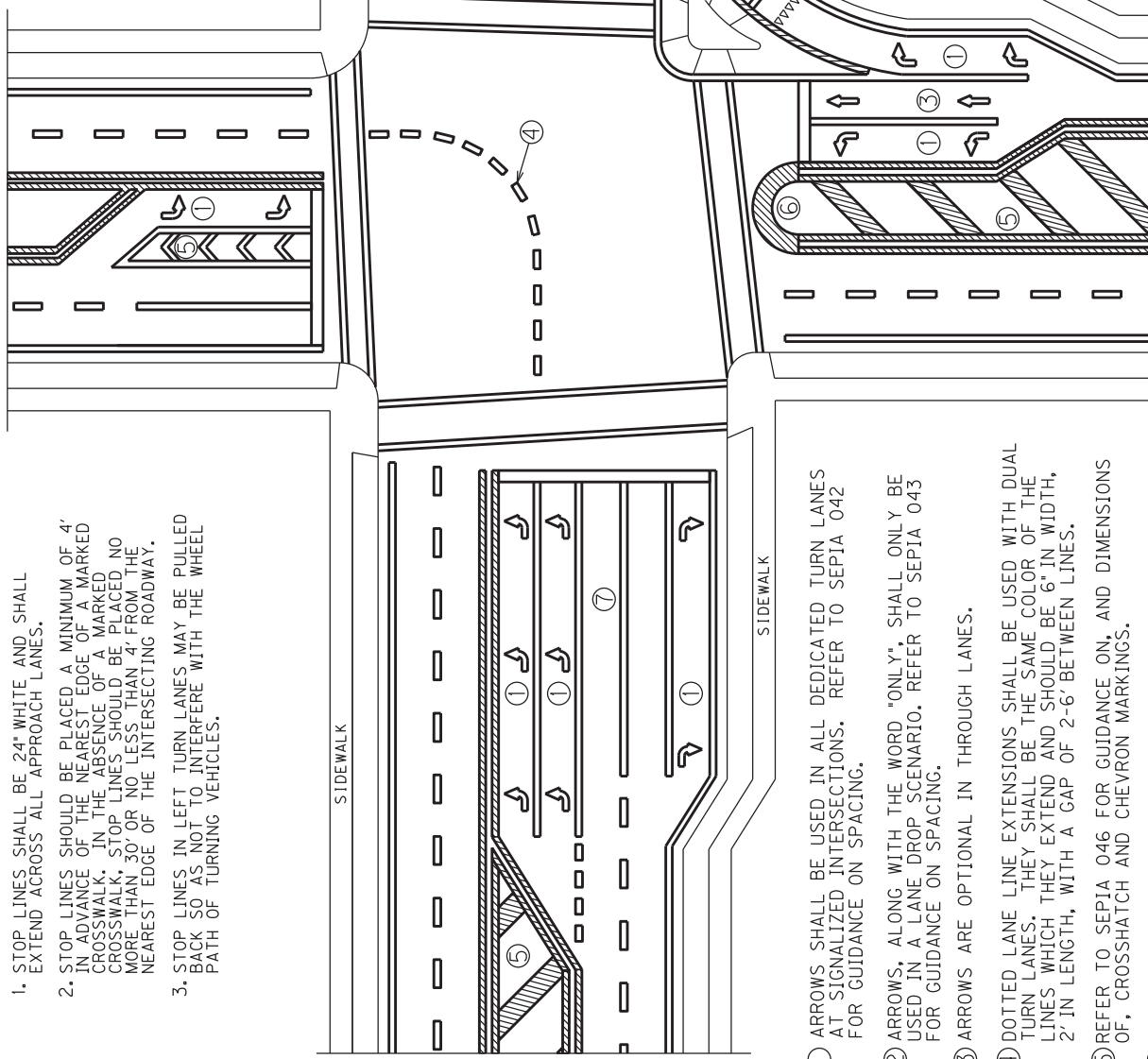

YIELD LINE DETAIL

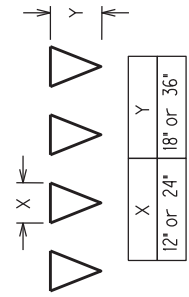

NOTE: SPACING BETWEEN TRIANGLES SHOULD BE 3-12"

DRAWING NOT TO SCALE

LEGEND	
MARKINGS	WHITE
	YELLOW

- ① ARROWS SHALL BE USED IN ALL DEDICATED TURN LANES AT SIGNALIZED INTERSECTIONS. REFER TO SEPIA 042 FOR GUIDANCE ON SPACING.
- ② ARROWS, ALONG WITH THE WORD "ONLY", SHALL ONLY BE USED IN A LANE DROP SCENARIO. REFER TO SEPIA 043 FOR GUIDANCE ON SPACING.
- ③ ARROWS ARE OPTIONAL IN THROUGH LANES.
- ④ DOTTED LANE LINE EXTENSIONS SHALL BE USED WITH DUAL TURN LANES. THEY SHALL BE THE SAME COLOR OF THE LINES WHICH THEY EXTEND AND SHOULD BE 6" IN WIDTH, 2' IN LENGTH, WITH A GAP OF 2-6' BETWEEN LINES.
- ⑤ REFER TO SEPIA 046 FOR GUIDANCE ON, AND DIMENSIONS OF, CROSSHATCH AND CHEVRON MARKINGS.
- ⑥ REFER TO SEPIA 046 FOR GUIDANCE ON MEDIAN NOSES.
- ⑦ SOLID LINE SEPARATING THROUGH LANES SHOULD EXTEND BACK A MINIMUM OF 50' FROM THE STOP BAR.

\*NOTE: OTHER THAN LONGITUDINAL STRIPING, ALL MARKINGS SHOWN ON THIS DRAWING SHOULD BE THERMOPLASTIC.

KENTUCKY  
 DEPARTMENT OF HIGHWAYS

**TYPICAL MARKINGS AT SIGNALIZED INTERSECTIONS**

SUBMITTED *R. [Signature]* DATE **04/16/16** PAGE 83 OF 131

COUNTY OF	ITEM NO.	SHEET NO.

### TYPICAL RIGHT-TURN CHANNELIZING ISLAND MARKINGS

**GENERAL NOTES**

THE MINIMUM WIDTH (X) OF CROSSHATCH MARKINGS IS 12" FOR LOW SPEED ROADS (<45 MPH) AND 24" FOR HIGH SPEED ROADS (≥45 MPH).

THE SPACE BETWEEN ADJACENT CROSSHATCH MARKINGS (Y) SHOULD BE SET AT 10 TIMES THE WIDTH (X) OF THE CROSSHATCH MARKINGS.

CROSSHATCH MARKINGS SHOULD NOT BE PLACED IN A MEDIAN LESS THAN 6' IN WIDTH.

CROSSHATCH MARKINGS SHOULD NOT BE PLACED IN AND ISLAND IF ANY SIDE OF AN ISLAND IS LESS THAN 30' IN LENGTH.

THE OUTLINE OF AN ISLAND SHOULD BE EITHER 8" OR 12".

MEDIAN NOSES MAY BE EITHER A SINGLE 12" LINE OR A SOLID SEMI-CIRCLE.

CROSSHATCH AND CHEVRON MARKINGS SHOULD BE THERMOPLASTIC.

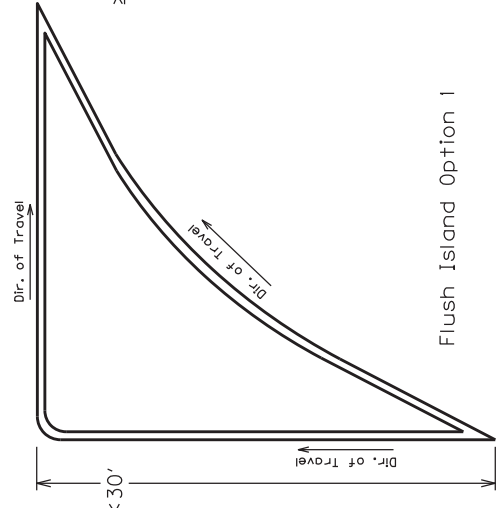
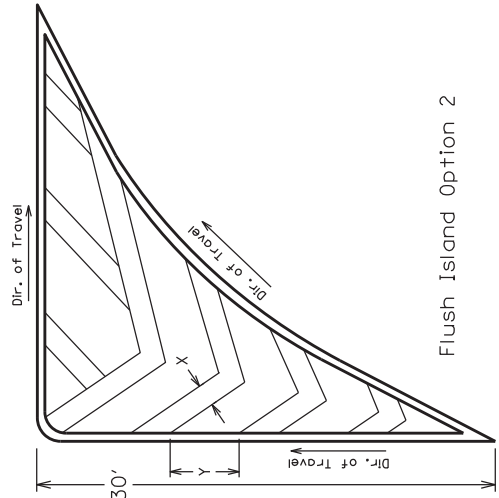
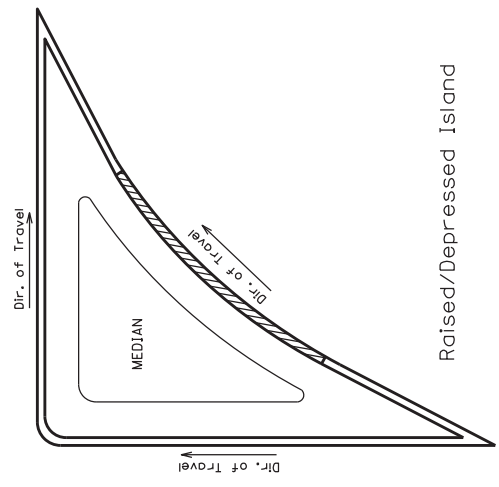

### TYPICAL LEFT-TURN LANE / FLUSH MEDIAN CROSSHATCH MARKINGS

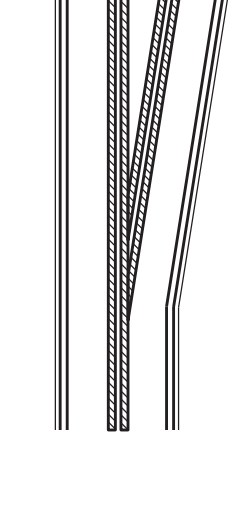
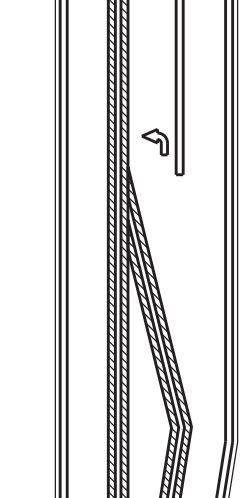
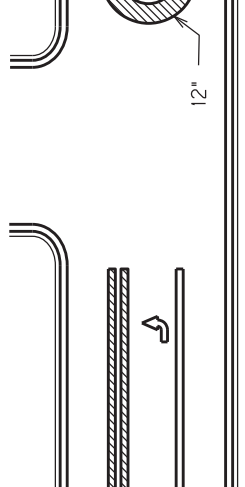
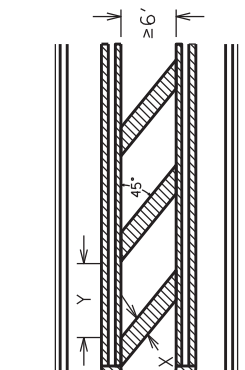

**LEGEND**

MARKINGS	WHITE
	YELLOW

**DRAWING NOT TO SCALE**

### TYPICAL TWO-WAY LEFT-TURN LANE (TWLTL) TRANSITION MARKINGS

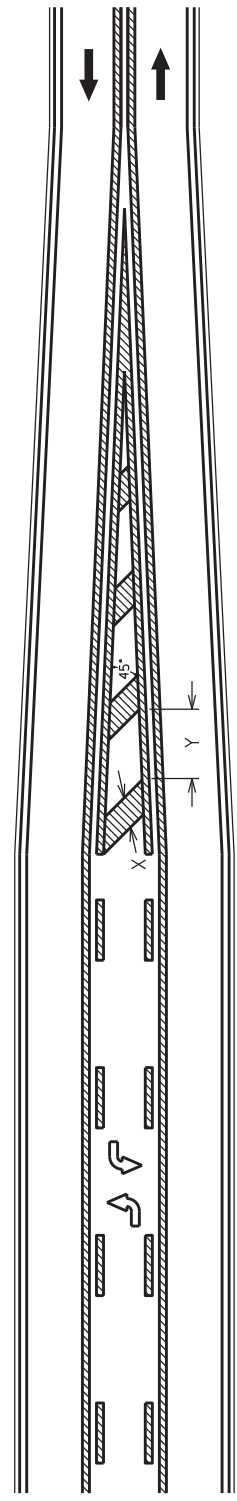

Note: Crosshatch markings shall be placed in the transition area of a TWLTL.

KENTUCKY  
 DEPARTMENT OF HIGHWAYS

**TYPICAL MARKINGS FOR ISLANDS AND MEDIANS**

DATE: 11-30-18  
 SUBMITTED BY: *R. [Signature]*  
 046

## **PART III**

### **EMPLOYMENT, WAGE AND RECORD REQUIREMENTS**

FHWA-1273 -- Revised May 1, 2012

## REQUIRED CONTRACT PROVISIONS FEDERAL-AID CONSTRUCTION CONTRACTS

- I. General
- II. Nondiscrimination
- III. Nonsegregated Facilities
- IV. Davis-Bacon and Related Act Provisions
- V. Contract Work Hours and Safety Standards Act Provisions
- VI. Subletting or Assigning the Contract
- VII. Safety: Accident Prevention
- VIII. False Statements Concerning Highway Projects
- IX. Implementation of Clean Air Act and Federal Water Pollution Control Act
- X. Compliance with Governmentwide Suspension and Debarment Requirements
- XI. Certification Regarding Use of Contract Funds for Lobbying

### ATTACHMENTS

A. Employment and Materials Preference for Appalachian Development Highway System or Appalachian Local Access Road Contracts (included in Appalachian contracts only)

### I. GENERAL

1. Form FHWA-1273 must be physically incorporated in each construction contract funded under Title 23 (excluding emergency contracts solely intended for debris removal). The contractor (or subcontractor) must insert this form in each subcontract and further require its inclusion in all lower tier subcontracts (excluding purchase orders, rental agreements and other agreements for supplies or services).

The applicable requirements of Form FHWA-1273 are incorporated by reference for work done under any purchase order, rental agreement or agreement for other services. The prime contractor shall be responsible for compliance by any subcontractor, lower-tier subcontractor or service provider.

Form FHWA-1273 must be included in all Federal-aid design-build contracts, in all subcontracts and in lower tier subcontracts (excluding subcontracts for design services, purchase orders, rental agreements and other agreements for supplies or services). The design-builder shall be responsible for compliance by any subcontractor, lower-tier subcontractor or service provider.

Contracting agencies may reference Form FHWA-1273 in bid proposal or request for proposal documents, however, the Form FHWA-1273 must be physically incorporated (not referenced) in all contracts, subcontracts and lower-tier subcontracts (excluding purchase orders, rental agreements and other agreements for supplies or services related to a construction contract).

2. Subject to the applicability criteria noted in the following sections, these contract provisions shall apply to all work performed on the contract by the contractor's own organization and with the assistance of workers under the contractor's immediate superintendence and to all work performed on the contract by piecework, station work, or by subcontract.

3. A breach of any of the stipulations contained in these Required Contract Provisions may be sufficient grounds for withholding of progress payments, withholding of final payment, termination of the contract, suspension / debarment or any other action determined to be appropriate by the contracting agency and FHWA.

4. Selection of Labor: During the performance of this contract, the contractor shall not use convict labor for any purpose within the limits of a construction project on a Federal-aid highway unless it is labor performed by convicts who are on parole, supervised release, or probation. The term Federal-aid highway does not include roadways functionally classified as local roads or rural minor collectors.

### II. NONDISCRIMINATION

The provisions of this section related to 23 CFR Part 230 are applicable to all Federal-aid construction contracts and to all related construction subcontracts of \$10,000 or more. The provisions of 23 CFR Part 230 are not applicable to material supply, engineering, or architectural service contracts.

In addition, the contractor and all subcontractors must comply with the following policies: Executive Order 11246, 41 CFR 60, 29 CFR 1625-1627, Title 23 USC Section 140, the Rehabilitation Act of 1973, as amended (29 USC 794), Title VI of the Civil Rights Act of 1964, as amended, and related regulations including 49 CFR Parts 21, 26 and 27; and 23 CFR Parts 200, 230, and 633.

The contractor and all subcontractors must comply with: the requirements of the Equal Opportunity Clause in 41 CFR 60-1.4(b) and, for all construction contracts exceeding \$10,000, the Standard Federal Equal Employment Opportunity Construction Contract Specifications in 41 CFR 60-4.3.

Note: The U.S. Department of Labor has exclusive authority to determine compliance with Executive Order 11246 and the policies of the Secretary of Labor including 41 CFR 60, and 29 CFR 1625-1627. The contracting agency and the FHWA have the authority and the responsibility to ensure compliance with Title 23 USC Section 140, the Rehabilitation Act of 1973, as amended (29 USC 794), and Title VI of the Civil Rights Act of 1964, as amended, and related regulations including 49 CFR Parts 21, 26 and 27; and 23 CFR Parts 200, 230, and 633.

The following provision is adopted from 23 CFR 230, Appendix A, with appropriate revisions to conform to the U.S. Department of Labor (US DOL) and FHWA requirements.

**1. Equal Employment Opportunity:** Equal employment opportunity (EEO) requirements not to discriminate and to take affirmative action to assure equal opportunity as set forth under laws, executive orders, rules, regulations (28 CFR 35, 29 CFR 1630, 29 CFR 1625-1627, 41 CFR 60 and 49 CFR 27) and orders of the Secretary of Labor as modified by the provisions prescribed herein, and imposed pursuant to 23 U.S.C. 140 shall constitute the EEO and specific affirmative action standards for the contractor's project activities under

this contract. The provisions of the Americans with Disabilities Act of 1990 (42 U.S.C. 12101 et seq.) set forth under 28 CFR 35 and 29 CFR 1630 are incorporated by reference in this contract. In the execution of this contract, the contractor agrees to comply with the following minimum specific requirement activities of EEO:

a. The contractor will work with the contracting agency and the Federal Government to ensure that it has made every good faith effort to provide equal opportunity with respect to all of its terms and conditions of employment and in their review of activities under the contract.

b. The contractor will accept as its operating policy the following statement:

"It is the policy of this Company to assure that applicants are employed, and that employees are treated during employment, without regard to their race, religion, sex, color, national origin, age or disability. Such action shall include: employment, upgrading, demotion, or transfer; recruitment or recruitment advertising; layoff or termination; rates of pay or other forms of compensation; and selection for training, including apprenticeship, pre-apprenticeship, and/or on-the-job training."

**2. EEO Officer:** The contractor will designate and make known to the contracting officers an EEO Officer who will have the responsibility for and must be capable of effectively administering and promoting an active EEO program and who must be assigned adequate authority and responsibility to do so.

**3. Dissemination of Policy:** All members of the contractor's staff who are authorized to hire, supervise, promote, and discharge employees, or who recommend such action, or who are substantially involved in such action, will be made fully cognizant of, and will implement, the contractor's EEO policy and contractual responsibilities to provide EEO in each grade and classification of employment. To ensure that the above agreement will be met, the following actions will be taken as a minimum:

a. Periodic meetings of supervisory and personnel office employees will be conducted before the start of work and then not less often than once every six months, at which time the contractor's EEO policy and its implementation will be reviewed and explained. The meetings will be conducted by the EEO Officer.

b. All new supervisory or personnel office employees will be given a thorough indoctrination by the EEO Officer, covering all major aspects of the contractor's EEO obligations within thirty days following their reporting for duty with the contractor.

c. All personnel who are engaged in direct recruitment for the project will be instructed by the EEO Officer in the contractor's procedures for locating and hiring minorities and women.

d. Notices and posters setting forth the contractor's EEO policy will be placed in areas readily accessible to employees, applicants for employment and potential employees.

e. The contractor's EEO policy and the procedures to implement such policy will be brought to the attention of employees by means of meetings, employee handbooks, or other appropriate means.

**4. Recruitment:** When advertising for employees, the contractor will include in all advertisements for employees the notation: "An Equal Opportunity Employer." All such advertisements will be placed in publications having a large circulation among minorities and women in the area from which the project work force would normally be derived.

a. The contractor will, unless precluded by a valid bargaining agreement, conduct systematic and direct recruitment through public and private employee referral sources likely to yield qualified minorities and women. To meet this requirement, the contractor will identify sources of potential minority group employees, and establish with such identified sources procedures whereby minority and women applicants may be referred to the contractor for employment consideration.

b. In the event the contractor has a valid bargaining agreement providing for exclusive hiring hall referrals, the contractor is expected to observe the provisions of that agreement to the extent that the system meets the contractor's compliance with EEO contract provisions. Where implementation of such an agreement has the effect of discriminating against minorities or women, or obligates the contractor to do the same, such implementation violates Federal nondiscrimination provisions.

c. The contractor will encourage its present employees to refer minorities and women as applicants for employment. Information and procedures with regard to referring such applicants will be discussed with employees.

**5. Personnel Actions:** Wages, working conditions, and employee benefits shall be established and administered, and personnel actions of every type, including hiring, upgrading, promotion, transfer, demotion, layoff, and termination, shall be taken without regard to race, color, religion, sex, national origin, age or disability. The following procedures shall be followed:

a. The contractor will conduct periodic inspections of project sites to insure that working conditions and employee facilities do not indicate discriminatory treatment of project site personnel.

b. The contractor will periodically evaluate the spread of wages paid within each classification to determine any evidence of discriminatory wage practices.

c. The contractor will periodically review selected personnel actions in depth to determine whether there is evidence of discrimination. Where evidence is found, the contractor will promptly take corrective action. If the review indicates that the discrimination may extend beyond the actions reviewed, such corrective action shall include all affected persons.

d. The contractor will promptly investigate all complaints of alleged discrimination made to the contractor in connection with its obligations under this contract, will attempt to resolve such complaints, and will take appropriate corrective action within a reasonable time. If the investigation indicates that the discrimination may affect persons other than the complainant, such corrective action shall include such other persons. Upon completion of each investigation, the contractor will inform every complainant of all of their avenues of appeal.

**6. Training and Promotion:**

a. The contractor will assist in locating, qualifying, and increasing the skills of minorities and women who are

applicants for employment or current employees. Such efforts should be aimed at developing full journey level status employees in the type of trade or job classification involved.

b. Consistent with the contractor's work force requirements and as permissible under Federal and State regulations, the contractor shall make full use of training programs, i.e., apprenticeship, and on-the-job training programs for the geographical area of contract performance. In the event a special provision for training is provided under this contract, this subparagraph will be superseded as indicated in the special provision. The contracting agency may reserve training positions for persons who receive welfare assistance in accordance with 23 U.S.C. 140(a).

c. The contractor will advise employees and applicants for employment of available training programs and entrance requirements for each.

d. The contractor will periodically review the training and promotion potential of employees who are minorities and women and will encourage eligible employees to apply for such training and promotion.

**7. Unions:** If the contractor relies in whole or in part upon unions as a source of employees, the contractor will use good faith efforts to obtain the cooperation of such unions to increase opportunities for minorities and women. Actions by the contractor, either directly or through a contractor's association acting as agent, will include the procedures set forth below:

a. The contractor will use good faith efforts to develop, in cooperation with the unions, joint training programs aimed toward qualifying more minorities and women for membership in the unions and increasing the skills of minorities and women so that they may qualify for higher paying employment.

b. The contractor will use good faith efforts to incorporate an EEO clause into each union agreement to the end that such union will be contractually bound to refer applicants without regard to their race, color, religion, sex, national origin, age or disability.

c. The contractor is to obtain information as to the referral practices and policies of the labor union except that to the extent such information is within the exclusive possession of the labor union and such labor union refuses to furnish such information to the contractor, the contractor shall so certify to the contracting agency and shall set forth what efforts have been made to obtain such information.

d. In the event the union is unable to provide the contractor with a reasonable flow of referrals within the time limit set forth in the collective bargaining agreement, the contractor will, through independent recruitment efforts, fill the employment vacancies without regard to race, color, religion, sex, national origin, age or disability; making full efforts to obtain qualified and/or qualifiable minorities and women. The failure of a union to provide sufficient referrals (even though it is obligated to provide exclusive referrals under the terms of a collective bargaining agreement) does not relieve the contractor from the requirements of this paragraph. In the event the union referral practice prevents the contractor from meeting the obligations pursuant to Executive Order 11246, as amended, and these special provisions, such contractor shall immediately notify the contracting agency.

**8. Reasonable Accommodation for Applicants / Employees with Disabilities:** The contractor must be familiar

with the requirements for and comply with the Americans with Disabilities Act and all rules and regulations established there under. Employers must provide reasonable accommodation in all employment activities unless to do so would cause an undue hardship.

**9. Selection of Subcontractors, Procurement of Materials and Leasing of Equipment:** The contractor shall not discriminate on the grounds of race, color, religion, sex, national origin, age or disability in the selection and retention of subcontractors, including procurement of materials and leases of equipment. The contractor shall take all necessary and reasonable steps to ensure nondiscrimination in the administration of this contract.

a. The contractor shall notify all potential subcontractors and suppliers and lessors of their EEO obligations under this contract.

b. The contractor will use good faith efforts to ensure subcontractor compliance with their EEO obligations.

**10. Assurance Required by 49 CFR 26.13(b):**

a. The requirements of 49 CFR Part 26 and the State DOT's U.S. DOT-approved DBE program are incorporated by reference.

b. The contractor or subcontractor shall not discriminate on the basis of race, color, national origin, or sex in the performance of this contract. The contractor shall carry out applicable requirements of 49 CFR Part 26 in the award and administration of DOT-assisted contracts. Failure by the contractor to carry out these requirements is a material breach of this contract, which may result in the termination of this contract or such other remedy as the contracting agency deems appropriate.

**11. Records and Reports:** The contractor shall keep such records as necessary to document compliance with the EEO requirements. Such records shall be retained for a period of three years following the date of the final payment to the contractor for all contract work and shall be available at reasonable times and places for inspection by authorized representatives of the contracting agency and the FHWA.

a. The records kept by the contractor shall document the following:

(1) The number and work hours of minority and non-minority group members and women employed in each work classification on the project;

(2) The progress and efforts being made in cooperation with unions, when applicable, to increase employment opportunities for minorities and women; and

(3) The progress and efforts being made in locating, hiring, training, qualifying, and upgrading minorities and women;

b. The contractors and subcontractors will submit an annual report to the contracting agency each July for the duration of the project, indicating the number of minority, women, and non-minority group employees currently engaged in each work classification required by the contract work. This information is to be reported on [Form FHWA-1391](#). The staffing data should represent the project work force on board in all or any part of the last payroll period preceding the end of July. If on-the-job training is being required by special provision, the contractor



will be required to collect and report training data. The employment data should reflect the work force on board during all or any part of the last payroll period preceding the end of July.

### III. NONSEGREGATED FACILITIES

This provision is applicable to all Federal-aid construction contracts and to all related construction subcontracts of \$10,000 or more.

The contractor must ensure that facilities provided for employees are provided in such a manner that segregation on the basis of race, color, religion, sex, or national origin cannot result. The contractor may neither require such segregated use by written or oral policies nor tolerate such use by employee custom. The contractor's obligation extends further to ensure that its employees are not assigned to perform their services at any location, under the contractor's control, where the facilities are segregated. The term "facilities" includes waiting rooms, work areas, restaurants and other eating areas, time clocks, restrooms, washrooms, locker rooms, and other storage or dressing areas, parking lots, drinking fountains, recreation or entertainment areas, transportation, and housing provided for employees. The contractor shall provide separate or single-user restrooms and necessary dressing or sleeping areas to assure privacy between sexes.

### IV. DAVIS-BACON AND RELATED ACT PROVISIONS

This section is applicable to all Federal-aid construction projects exceeding \$2,000 and to all related subcontracts and lower-tier subcontracts (regardless of subcontract size). The requirements apply to all projects located within the right-of-way of a roadway that is functionally classified as Federal-aid highway. This excludes roadways functionally classified as local roads or rural minor collectors, which are exempt. Contracting agencies may elect to apply these requirements to other projects.

The following provisions are from the U.S. Department of Labor regulations in 29 CFR 5.5 "Contract provisions and related matters" with minor revisions to conform to the FHWA-1273 format and FHWA program requirements.

#### 1. Minimum wages

a. All laborers and mechanics employed or working upon the site of the work, will be paid unconditionally and not less often than once a week, and without subsequent deduction or rebate on any account (except such payroll deductions as are permitted by regulations issued by the Secretary of Labor under the Copeland Act (29 CFR part 3)), the full amount of wages and bona fide fringe benefits (or cash equivalents thereof) due at time of payment computed at rates not less than those contained in the wage determination of the Secretary of Labor which is attached hereto and made a part hereof, regardless of any contractual relationship which may be alleged to exist between the contractor and such laborers and mechanics.

Contributions made or costs reasonably anticipated for bona fide fringe benefits under section 1(b)(2) of the Davis-Bacon Act on behalf of laborers or mechanics are considered wages paid to such laborers or mechanics, subject to the provisions

of paragraph 1.d. of this section; also, regular contributions made or costs incurred for more than a weekly period (but not less often than quarterly) under plans, funds, or programs which cover the particular weekly period, are deemed to be constructively made or incurred during such weekly period. Such laborers and mechanics shall be paid the appropriate wage rate and fringe benefits on the wage determination for the classification of work actually performed, without regard to skill, except as provided in 29 CFR 5.5(a)(4). Laborers or mechanics performing work in more than one classification may be compensated at the rate specified for each classification for the time actually worked therein: Provided, That the employer's payroll records accurately set forth the time spent in each classification in which work is performed. The wage determination (including any additional classification and wage rates conformed under paragraph 1.b. of this section) and the Davis-Bacon poster (WH-1321) shall be posted at all times by the contractor and its subcontractors at the site of the work in a prominent and accessible place where it can be easily seen by the workers.

b.(1) The contracting officer shall require that any class of laborers or mechanics, including helpers, which is not listed in the wage determination and which is to be employed under the contract shall be classified in conformance with the wage determination. The contracting officer shall approve an additional classification and wage rate and fringe benefits therefore only when the following criteria have been met:

(i) The work to be performed by the classification requested is not performed by a classification in the wage determination; and

(ii) The classification is utilized in the area by the construction industry; and

(iii) The proposed wage rate, including any bona fide fringe benefits, bears a reasonable relationship to the wage rates contained in the wage determination.

(2) If the contractor and the laborers and mechanics to be employed in the classification (if known), or their representatives, and the contracting officer agree on the classification and wage rate (including the amount designated for fringe benefits where appropriate), a report of the action taken shall be sent by the contracting officer to the Administrator of the Wage and Hour Division, Employment Standards Administration, U.S. Department of Labor, Washington, DC 20210. The Administrator, or an authorized representative, will approve, modify, or disapprove every additional classification action within 30 days of receipt and so advise the contracting officer or will notify the contracting officer within the 30-day period that additional time is necessary.

(3) In the event the contractor, the laborers or mechanics to be employed in the classification or their representatives, and the contracting officer do not agree on the proposed classification and wage rate (including the amount designated for fringe benefits, where appropriate), the contracting officer shall refer the questions, including the views of all interested parties and the recommendation of the contracting officer, to the Wage and Hour Administrator for determination. The Wage and Hour Administrator, or an authorized representative, will issue a determination within 30 days of receipt and so advise the contracting officer or

will notify the contracting officer within the 30-day period that additional time is necessary.

(4) The wage rate (including fringe benefits where appropriate) determined pursuant to paragraphs 1.b.(2) or 1.b.(3) of this section, shall be paid to all workers performing work in the classification under this contract from the first day on which work is performed in the classification.

c. Whenever the minimum wage rate prescribed in the contract for a class of laborers or mechanics includes a fringe benefit which is not expressed as an hourly rate, the contractor shall either pay the benefit as stated in the wage determination or shall pay another bona fide fringe benefit or an hourly cash equivalent thereof.

d. If the contractor does not make payments to a trustee or other third person, the contractor may consider as part of the wages of any laborer or mechanic the amount of any costs reasonably anticipated in providing bona fide fringe benefits under a plan or program. Provided, That the Secretary of Labor has found, upon the written request of the contractor, that the applicable standards of the Davis-Bacon Act have been met. The Secretary of Labor may require the contractor to set aside in a separate account assets for the meeting of obligations under the plan or program.

## 2. Withholding

The contracting agency shall upon its own action or upon written request of an authorized representative of the Department of Labor, withhold or cause to be withheld from the contractor under this contract, or any other Federal contract with the same prime contractor, or any other federally-assisted contract subject to Davis-Bacon prevailing wage requirements, which is held by the same prime contractor, so much of the accrued payments or advances as may be considered necessary to pay laborers and mechanics, including apprentices, trainees, and helpers, employed by the contractor or any subcontractor the full amount of wages required by the contract. In the event of failure to pay any laborer or mechanic, including any apprentice, trainee, or helper, employed or working on the site of the work, all or part of the wages required by the contract, the contracting agency may, after written notice to the contractor, take such action as may be necessary to cause the suspension of any further payment, advance, or guarantee of funds until such violations have ceased.

## 3. Payrolls and basic records

a. Payrolls and basic records relating thereto shall be maintained by the contractor during the course of the work and preserved for a period of three years thereafter for all laborers and mechanics working at the site of the work. Such records shall contain the name, address, and social security number of each such worker, his or her correct classification, hourly rates of wages paid (including rates of contributions or costs anticipated for bona fide fringe benefits or cash equivalents thereof of the types described in section 1(b)(2)(B) of the Davis-Bacon Act), daily and weekly number of hours worked, deductions made and actual wages paid. Whenever the Secretary of Labor has found under 29 CFR 5.5(a)(1)(iv) that the wages of any laborer or mechanic include the amount of any costs reasonably anticipated in providing benefits under a plan or program described in section 1(b)(2)(B) of the Davis-

Bacon Act, the contractor shall maintain records which show that the commitment to provide such benefits is enforceable, that the plan or program is financially responsible, and that the plan or program has been communicated in writing to the laborers or mechanics affected, and records which show the costs anticipated or the actual cost incurred in providing such benefits. Contractors employing apprentices or trainees under approved programs shall maintain written evidence of the registration of apprenticeship programs and certification of trainee programs, the registration of the apprentices and trainees, and the ratios and wage rates prescribed in the applicable programs.

b.(1) The contractor shall submit weekly for each week in which any contract work is performed a copy of all payrolls to the contracting agency. The payrolls submitted shall set out accurately and completely all of the information required to be maintained under 29 CFR 5.5(a)(3)(i), except that full social security numbers and home addresses shall not be included on weekly transmittals. Instead the payrolls shall only need to include an individually identifying number for each employee (e.g., the last four digits of the employee's social security number). The required weekly payroll information may be submitted in any form desired. Optional Form WH-347 is available for this purpose from the Wage and Hour Division Web site at <http://www.dol.gov/esa/whd/forms/wh347instr.htm> or its successor site. The prime contractor is responsible for the submission of copies of payrolls by all subcontractors. Contractors and subcontractors shall maintain the full social security number and current address of each covered worker, and shall provide them upon request to the contracting agency for transmission to the State DOT, the FHWA or the Wage and Hour Division of the Department of Labor for purposes of an investigation or audit of compliance with prevailing wage requirements. It is not a violation of this section for a prime contractor to require a subcontractor to provide addresses and social security numbers to the prime contractor for its own records, without weekly submission to the contracting agency..

(2) Each payroll submitted shall be accompanied by a "Statement of Compliance," signed by the contractor or subcontractor or his or her agent who pays or supervises the payment of the persons employed under the contract and shall certify the following:

(i) That the payroll for the payroll period contains the information required to be provided under §5.5 (a)(3)(ii) of Regulations, 29 CFR part 5, the appropriate information is being maintained under §5.5 (a)(3)(i) of Regulations, 29 CFR part 5, and that such information is correct and complete;

(ii) That each laborer or mechanic (including each helper, apprentice, and trainee) employed on the contract during the payroll period has been paid the full weekly wages earned, without rebate, either directly or indirectly, and that no deductions have been made either directly or indirectly from the full wages earned, other than permissible deductions as set forth in Regulations, 29 CFR part 3;

(iii) That each laborer or mechanic has been paid not less than the applicable wage rates and fringe benefits or cash equivalents for the classification of work performed, as specified in the applicable wage determination incorporated into the contract.

(3) The weekly submission of a properly executed certification set forth on the reverse side of Optional Form WH-347 shall satisfy the requirement for submission of the "Statement of Compliance" required by paragraph 3.b.(2) of this section.

(4) The falsification of any of the above certifications may subject the contractor or subcontractor to civil or criminal prosecution under section 1001 of title 18 and section 231 of title 31 of the United States Code.

c. The contractor or subcontractor shall make the records required under paragraph 3.a. of this section available for inspection, copying, or transcription by authorized representatives of the contracting agency, the State DOT, the FHWA, or the Department of Labor, and shall permit such representatives to interview employees during working hours on the job. If the contractor or subcontractor fails to submit the required records or to make them available, the FHWA may, after written notice to the contractor, the contracting agency or the State DOT, take such action as may be necessary to cause the suspension of any further payment, advance, or guarantee of funds. Furthermore, failure to submit the required records upon request or to make such records available may be grounds for debarment action pursuant to 29 CFR 5.12.

#### 4. Apprentices and trainees

##### a. Apprentices (programs of the USDOL).

Apprentices will be permitted to work at less than the predetermined rate for the work they performed when they are employed pursuant to and individually registered in a bona fide apprenticeship program registered with the U.S. Department of Labor, Employment and Training Administration, Office of Apprenticeship Training, Employer and Labor Services, or with a State Apprenticeship Agency recognized by the Office, or if a person is employed in his or her first 90 days of probationary employment as an apprentice in such an apprenticeship program, who is not individually registered in the program, but who has been certified by the Office of Apprenticeship Training, Employer and Labor Services or a State Apprenticeship Agency (where appropriate) to be eligible for probationary employment as an apprentice.

The allowable ratio of apprentices to journeymen on the job site in any craft classification shall not be greater than the ratio permitted to the contractor as to the entire work force under the registered program. Any worker listed on a payroll at an apprentice wage rate, who is not registered or otherwise employed as stated above, shall be paid not less than the applicable wage rate on the wage determination for the classification of work actually performed. In addition, any apprentice performing work on the job site in excess of the ratio permitted under the registered program shall be paid not less than the applicable wage rate on the wage determination for the work actually performed. Where a contractor is performing construction on a project in a locality other than that in which its program is registered, the ratios and wage rates (expressed in percentages of the journeyman's hourly rate) specified in the contractor's or subcontractor's registered program shall be observed.

Every apprentice must be paid at not less than the rate specified in the registered program for the apprentice's level of progress, expressed as a percentage of the journeymen hourly

rate specified in the applicable wage determination. Apprentices shall be paid fringe benefits in accordance with the provisions of the apprenticeship program. If the apprenticeship program does not specify fringe benefits, apprentices must be paid the full amount of fringe benefits listed on the wage determination for the applicable classification. If the Administrator determines that a different practice prevails for the applicable apprentice classification, fringes shall be paid in accordance with that determination.

In the event the Office of Apprenticeship Training, Employer and Labor Services, or a State Apprenticeship Agency recognized by the Office, withdraws approval of an apprenticeship program, the contractor will no longer be permitted to utilize apprentices at less than the applicable predetermined rate for the work performed until an acceptable program is approved.

##### b. Trainees (programs of the USDOL).

Except as provided in 29 CFR 5.16, trainees will not be permitted to work at less than the predetermined rate for the work performed unless they are employed pursuant to and individually registered in a program which has received prior approval, evidenced by formal certification by the U.S. Department of Labor, Employment and Training Administration.

The ratio of trainees to journeymen on the job site shall not be greater than permitted under the plan approved by the Employment and Training Administration.

Every trainee must be paid at not less than the rate specified in the approved program for the trainee's level of progress, expressed as a percentage of the journeyman hourly rate specified in the applicable wage determination. Trainees shall be paid fringe benefits in accordance with the provisions of the trainee program. If the trainee program does not mention fringe benefits, trainees shall be paid the full amount of fringe benefits listed on the wage determination unless the Administrator of the Wage and Hour Division determines that there is an apprenticeship program associated with the corresponding journeyman wage rate on the wage determination which provides for less than full fringe benefits for apprentices. Any employee listed on the payroll at a trainee rate who is not registered and participating in a training plan approved by the Employment and Training Administration shall be paid not less than the applicable wage rate on the wage determination for the classification of work actually performed. In addition, any trainee performing work on the job site in excess of the ratio permitted under the registered program shall be paid not less than the applicable wage rate on the wage determination for the work actually performed.

In the event the Employment and Training Administration withdraws approval of a training program, the contractor will no longer be permitted to utilize trainees at less than the applicable predetermined rate for the work performed until an acceptable program is approved.

c. Equal employment opportunity. The utilization of apprentices, trainees and journeymen under this part shall be in conformity with the equal employment opportunity requirements of Executive Order 11246, as amended, and 29 CFR part 30.

d. Apprentices and Trainees (programs of the U.S. DOT).

Apprentices and trainees working under apprenticeship and skill training programs which have been certified by the Secretary of Transportation as promoting EEO in connection with Federal-aid highway construction programs are not subject to the requirements of paragraph 4 of this Section IV. The straight time hourly wage rates for apprentices and trainees under such programs will be established by the particular programs. The ratio of apprentices and trainees to journeymen shall not be greater than permitted by the terms of the particular program.

**5. Compliance with Copeland Act requirements.** The contractor shall comply with the requirements of 29 CFR part 3, which are incorporated by reference in this contract.

**6. Subcontracts.** The contractor or subcontractor shall insert Form FHWA-1273 in any subcontracts and also require the subcontractors to include Form FHWA-1273 in any lower tier subcontracts. The prime contractor shall be responsible for the compliance by any subcontractor or lower tier subcontractor with all the contract clauses in 29 CFR 5.5.

**7. Contract termination: debarment.** A breach of the contract clauses in 29 CFR 5.5 may be grounds for termination of the contract, and for debarment as a contractor and a subcontractor as provided in 29 CFR 5.12.

**8. Compliance with Davis-Bacon and Related Act requirements.** All rulings and interpretations of the Davis-Bacon and Related Acts contained in 29 CFR parts 1, 3, and 5 are herein incorporated by reference in this contract.

**9. Disputes concerning labor standards.** Disputes arising out of the labor standards provisions of this contract shall not be subject to the general disputes clause of this contract. Such disputes shall be resolved in accordance with the procedures of the Department of Labor set forth in 29 CFR parts 5, 6, and 7. Disputes within the meaning of this clause include disputes between the contractor (or any of its subcontractors) and the contracting agency, the U.S. Department of Labor, or the employees or their representatives.

**10. Certification of eligibility.**

a. By entering into this contract, the contractor certifies that neither it (nor he or she) nor any person or firm who has an interest in the contractor's firm is a person or firm ineligible to be awarded Government contracts by virtue of section 3(a) of the Davis-Bacon Act or 29 CFR 5.12(a)(1).

b. No part of this contract shall be subcontracted to any person or firm ineligible for award of a Government contract by virtue of section 3(a) of the Davis-Bacon Act or 29 CFR 5.12(a)(1).

c. The penalty for making false statements is prescribed in the U.S. Criminal Code, 18 U.S.C. 1001.

**V. CONTRACT WORK HOURS AND SAFETY STANDARDS ACT**

The following clauses apply to any Federal-aid construction contract in an amount in excess of \$100,000 and subject to the overtime provisions of the Contract Work Hours and Safety Standards Act. These clauses shall be inserted in addition to the clauses required by 29 CFR 5.5(a) or 29 CFR 4.6. As used in this paragraph, the terms laborers and mechanics include watchmen and guards.

**1. Overtime requirements.** No contractor or subcontractor contracting for any part of the contract work which may require or involve the employment of laborers or mechanics shall require or permit any such laborer or mechanic in any workweek in which he or she is employed on such work to work in excess of forty hours in such workweek unless such laborer or mechanic receives compensation at a rate not less than one and one-half times the basic rate of pay for all hours worked in excess of forty hours in such workweek.

**2. Violation; liability for unpaid wages; liquidated damages.** In the event of any violation of the clause set forth in paragraph (1.) of this section, the contractor and any subcontractor responsible therefor shall be liable for the unpaid wages. In addition, such contractor and subcontractor shall be liable to the United States (in the case of work done under contract for the District of Columbia or a territory, to such District or to such territory), for liquidated damages. Such liquidated damages shall be computed with respect to each individual laborer or mechanic, including watchmen and guards, employed in violation of the clause set forth in paragraph (1.) of this section, in the sum of \$10 for each calendar day on which such individual was required or permitted to work in excess of the standard workweek of forty hours without payment of the overtime wages required by the clause set forth in paragraph (1.) of this section.

**3. Withholding for unpaid wages and liquidated damages.** The FHWA or the contracting agency shall upon its own action or upon written request of an authorized representative of the Department of Labor withhold or cause to be withheld, from any moneys payable on account of work performed by the contractor or subcontractor under any such contract or any other Federal contract with the same prime contractor, or any other federally-assisted contract subject to the Contract Work Hours and Safety Standards Act, which is held by the same prime contractor, such sums as may be determined to be necessary to satisfy any liabilities of such contractor or subcontractor for unpaid wages and liquidated damages as provided in the clause set forth in paragraph (2.) of this section.

**4. Subcontracts.** The contractor or subcontractor shall insert in any subcontracts the clauses set forth in paragraph (1.) through (4.) of this section and also a clause requiring the subcontractors to include these clauses in any lower tier subcontracts. The prime contractor shall be responsible for compliance by any subcontractor or lower tier subcontractor with the clauses set forth in paragraphs (1.) through (4.) of this section.

## VI. SUBLETTING OR ASSIGNING THE CONTRACT

This provision is applicable to all Federal-aid construction contracts on the National Highway System.

1. The contractor shall perform with its own organization contract work amounting to not less than 30 percent (or a greater percentage if specified elsewhere in the contract) of the total original contract price, excluding any specialty items designated by the contracting agency. Specialty items may be performed by subcontract and the amount of any such specialty items performed may be deducted from the total original contract price before computing the amount of work required to be performed by the contractor's own organization (23 CFR 635.116).

a. The term "perform work with its own organization" refers to workers employed or leased by the prime contractor, and equipment owned or rented by the prime contractor, with or without operators. Such term does not include employees or equipment of a subcontractor or lower tier subcontractor, agents of the prime contractor, or any other assignees. The term may include payments for the costs of hiring leased employees from an employee leasing firm meeting all relevant Federal and State regulatory requirements. Leased employees may only be included in this term if the prime contractor meets all of the following conditions:

- (1) the prime contractor maintains control over the supervision of the day-to-day activities of the leased employees;
- (2) the prime contractor remains responsible for the quality of the work of the leased employees;
- (3) the prime contractor retains all power to accept or exclude individual employees from work on the project; and
- (4) the prime contractor remains ultimately responsible for the payment of predetermined minimum wages, the submission of payrolls, statements of compliance and all other Federal regulatory requirements.

b. "Specialty Items" shall be construed to be limited to work that requires highly specialized knowledge, abilities, or equipment not ordinarily available in the type of contracting organizations qualified and expected to bid or propose on the contract as a whole and in general are to be limited to minor components of the overall contract.

2. The contract amount upon which the requirements set forth in paragraph (1) of Section VI is computed includes the cost of material and manufactured products which are to be purchased or produced by the contractor under the contract provisions.

3. The contractor shall furnish (a) a competent superintendent or supervisor who is employed by the firm, has full authority to direct performance of the work in accordance with the contract requirements, and is in charge of all construction operations (regardless of who performs the work) and (b) such other of its own organizational resources (supervision, management, and engineering services) as the contracting officer determines is necessary to assure the performance of the contract.

4. No portion of the contract shall be sublet, assigned or otherwise disposed of except with the written consent of the contracting officer, or authorized representative, and such consent when given shall not be construed to relieve the contractor of any responsibility for the fulfillment of the contract. Written consent will be given only after the contracting agency has assured that each subcontract is

evidenced in writing and that it contains all pertinent provisions and requirements of the prime contract.

5. The 30% self-performance requirement of paragraph (1) is not applicable to design-build contracts; however, contracting agencies may establish their own self-performance requirements.

## VII. SAFETY: ACCIDENT PREVENTION

This provision is applicable to all Federal-aid construction contracts and to all related subcontracts.

1. In the performance of this contract the contractor shall comply with all applicable Federal, State, and local laws governing safety, health, and sanitation (23 CFR 635). The contractor shall provide all safeguards, safety devices and protective equipment and take any other needed actions as it determines, or as the contracting officer may determine, to be reasonably necessary to protect the life and health of employees on the job and the safety of the public and to protect property in connection with the performance of the work covered by the contract.

2. It is a condition of this contract, and shall be made a condition of each subcontract, which the contractor enters into pursuant to this contract, that the contractor and any subcontractor shall not permit any employee, in performance of the contract, to work in surroundings or under conditions which are unsanitary, hazardous or dangerous to his/her health or safety, as determined under construction safety and health standards (29 CFR 1926) promulgated by the Secretary of Labor, in accordance with Section 107 of the Contract Work Hours and Safety Standards Act (40 U.S.C. 3704).

3. Pursuant to 29 CFR 1926.3, it is a condition of this contract that the Secretary of Labor or authorized representative thereof, shall have right of entry to any site of contract performance to inspect or investigate the matter of compliance with the construction safety and health standards and to carry out the duties of the Secretary under Section 107 of the Contract Work Hours and Safety Standards Act (40 U.S.C.3704).

## VIII. FALSE STATEMENTS CONCERNING HIGHWAY PROJECTS

This provision is applicable to all Federal-aid construction contracts and to all related subcontracts.

In order to assure high quality and durable construction in conformity with approved plans and specifications and a high degree of reliability on statements and representations made by engineers, contractors, suppliers, and workers on Federal-aid highway projects, it is essential that all persons concerned with the project perform their functions as carefully, thoroughly, and honestly as possible. Willful falsification, distortion, or misrepresentation with respect to any facts related to the project is a violation of Federal law. To prevent any misunderstanding regarding the seriousness of these and similar acts, Form FHWA-1022 shall be posted on each Federal-aid highway project (23 CFR 635) in one or more places where it is readily available to all persons concerned with the project:

18 U.S.C. 1020 reads as follows:

"Whoever, being an officer, agent, or employee of the United States, or of any State or Territory, or whoever, whether a person, association, firm, or corporation, knowingly makes any false statement, false representation, or false report as to the character, quality, quantity, or cost of the material used or to be used, or the quantity or quality of the work performed or to be performed, or the cost thereof in connection with the submission of plans, maps, specifications, contracts, or costs of construction on any highway or related project submitted for approval to the Secretary of Transportation; or

Whoever knowingly makes any false statement, false representation, false report or false claim with respect to the character, quality, quantity, or cost of any work performed or to be performed, or materials furnished or to be furnished, in connection with the construction of any highway or related project approved by the Secretary of Transportation; or

Whoever knowingly makes any false statement or false representation as to material fact in any statement, certificate, or report submitted pursuant to provisions of the Federal-aid Roads Act approved July 1, 1916, (39 Stat. 355), as amended and supplemented;

Shall be fined under this title or imprisoned not more than 5 years or both."

#### **IX. IMPLEMENTATION OF CLEAN AIR ACT AND FEDERAL WATER POLLUTION CONTROL ACT**

This provision is applicable to all Federal-aid construction contracts and to all related subcontracts.

By submission of this bid/proposal or the execution of this contract, or subcontract, as appropriate, the bidder, proposer, Federal-aid construction contractor, or subcontractor, as appropriate, will be deemed to have stipulated as follows:

1. That any person who is or will be utilized in the performance of this contract is not prohibited from receiving an award due to a violation of Section 508 of the Clean Water Act or Section 306 of the Clean Air Act.

2. That the contractor agrees to include or cause to be included the requirements of paragraph (1) of this Section X in every subcontract, and further agrees to take such action as the contracting agency may direct as a means of enforcing such requirements.

#### **X. CERTIFICATION REGARDING DEBARMENT, SUSPENSION, INELIGIBILITY AND VOLUNTARY EXCLUSION**

This provision is applicable to all Federal-aid construction contracts, design-build contracts, subcontracts, lower-tier subcontracts, purchase orders, lease agreements, consultant contracts or any other covered transaction requiring FHWA approval or that is estimated to cost \$25,000 or more – as defined in 2 CFR Parts 180 and 1200.

##### **1. Instructions for Certification – First Tier Participants:**

a. By signing and submitting this proposal, the prospective first tier participant is providing the certification set out below.

b. The inability of a person to provide the certification set out below will not necessarily result in denial of participation in this

covered transaction. The prospective first tier participant shall submit an explanation of why it cannot provide the certification set out below. The certification or explanation will be considered in connection with the department or agency's determination whether to enter into this transaction. However, failure of the prospective first tier participant to furnish a certification or an explanation shall disqualify such a person from participation in this transaction.

c. The certification in this clause is a material representation of fact upon which reliance was placed when the contracting agency determined to enter into this transaction. If it is later determined that the prospective participant knowingly rendered an erroneous certification, in addition to other remedies available to the Federal Government, the contracting agency may terminate this transaction for cause of default.

d. The prospective first tier participant shall provide immediate written notice to the contracting agency to whom this proposal is submitted if any time the prospective first tier participant learns that its certification was erroneous when submitted or has become erroneous by reason of changed circumstances.

e. The terms "covered transaction," "debarred," "suspended," "ineligible," "participant," "person," "principal," and "voluntarily excluded," as used in this clause, are defined in 2 CFR Parts 180 and 1200. "First Tier Covered Transactions" refers to any covered transaction between a grantee or subgrantee of Federal funds and a participant (such as the prime or general contract). "Lower Tier Covered Transactions" refers to any covered transaction under a First Tier Covered Transaction (such as subcontracts). "First Tier Participant" refers to the participant who has entered into a covered transaction with a grantee or subgrantee of Federal funds (such as the prime or general contractor). "Lower Tier Participant" refers any participant who has entered into a covered transaction with a First Tier Participant or other Lower Tier Participants (such as subcontractors and suppliers).

f. The prospective first tier participant agrees by submitting this proposal that, should the proposed covered transaction be entered into, it shall not knowingly enter into any lower tier covered transaction with a person who is debarred, suspended, declared ineligible, or voluntarily excluded from participation in this covered transaction, unless authorized by the department or agency entering into this transaction.

g. The prospective first tier participant further agrees by submitting this proposal that it will include the clause titled "Certification Regarding Debarment, Suspension, Ineligibility and Voluntary Exclusion-Lower Tier Covered Transactions," provided by the department or contracting agency, entering into this covered transaction, without modification, in all lower tier covered transactions and in all solicitations for lower tier covered transactions exceeding the \$25,000 threshold.

h. A participant in a covered transaction may rely upon a certification of a prospective participant in a lower tier covered transaction that is not debarred, suspended, ineligible, or voluntarily excluded from the covered transaction, unless it knows that the certification is erroneous. A participant is responsible for ensuring that its principals are not suspended, debarred, or otherwise ineligible to participate in covered transactions. To verify the eligibility of its principals, as well as the eligibility of any lower tier prospective participants, each participant may, but is not required to, check the Excluded Parties List System website (<https://www.epls.gov/>), which is compiled by the General Services Administration.

i. Nothing contained in the foregoing shall be construed to require the establishment of a system of records in order to render in good faith the certification required by this clause. The knowledge and information of the prospective participant is not required to exceed that which is normally possessed by a prudent person in the ordinary course of business dealings.

j. Except for transactions authorized under paragraph (f) of these instructions, if a participant in a covered transaction knowingly enters into a lower tier covered transaction with a person who is suspended, debarred, ineligible, or voluntarily excluded from participation in this transaction, in addition to other remedies available to the Federal Government, the department or agency may terminate this transaction for cause or default.

\* \* \* \* \*

**2. Certification Regarding Debarment, Suspension, Ineligibility and Voluntary Exclusion – First Tier Participants:**

a. The prospective first tier participant certifies to the best of its knowledge and belief, that it and its principals:

(1) Are not presently debarred, suspended, proposed for debarment, declared ineligible, or voluntarily excluded from participating in covered transactions by any Federal department or agency;

(2) Have not within a three-year period preceding this proposal been convicted of or had a civil judgment rendered against them for commission of fraud or a criminal offense in connection with obtaining, attempting to obtain, or performing a public (Federal, State or local) transaction or contract under a public transaction; violation of Federal or State antitrust statutes or commission of embezzlement, theft, forgery, bribery, falsification or destruction of records, making false statements, or receiving stolen property;

(3) Are not presently indicted for or otherwise criminally or civilly charged by a governmental entity (Federal, State or local) with commission of any of the offenses enumerated in paragraph (a)(2) of this certification; and

(4) Have not within a three-year period preceding this application/proposal had one or more public transactions (Federal, State or local) terminated for cause or default.

b. Where the prospective participant is unable to certify to any of the statements in this certification, such prospective participant shall attach an explanation to this proposal.

**2. Instructions for Certification - Lower Tier Participants:**

(Applicable to all subcontracts, purchase orders and other lower tier transactions requiring prior FHWA approval or estimated to cost \$25,000 or more - 2 CFR Parts 180 and 1200)

a. By signing and submitting this proposal, the prospective lower tier is providing the certification set out below.

b. The certification in this clause is a material representation of fact upon which reliance was placed when this transaction was entered into. If it is later determined that the prospective lower tier participant knowingly rendered an erroneous certification, in addition to other remedies available to the Federal Government, the department, or agency with which

this transaction originated may pursue available remedies, including suspension and/or debarment.

c. The prospective lower tier participant shall provide immediate written notice to the person to which this proposal is submitted if at any time the prospective lower tier participant learns that its certification was erroneous by reason of changed circumstances.

d. The terms "covered transaction," "debarred," "suspended," "ineligible," "participant," "person," "principal," and "voluntarily excluded," as used in this clause, are defined in 2 CFR Parts 180 and 1200. You may contact the person to which this proposal is submitted for assistance in obtaining a copy of those regulations. "First Tier Covered Transactions" refers to any covered transaction between a grantee or subgrantee of Federal funds and a participant (such as the prime or general contract). "Lower Tier Covered Transactions" refers to any covered transaction under a First Tier Covered Transaction (such as subcontracts). "First Tier Participant" refers to the participant who has entered into a covered transaction with a grantee or subgrantee of Federal funds (such as the prime or general contractor). "Lower Tier Participant" refers any participant who has entered into a covered transaction with a First Tier Participant or other Lower Tier Participants (such as subcontractors and suppliers).

e. The prospective lower tier participant agrees by submitting this proposal that, should the proposed covered transaction be entered into, it shall not knowingly enter into any lower tier covered transaction with a person who is debarred, suspended, declared ineligible, or voluntarily excluded from participation in this covered transaction, unless authorized by the department or agency with which this transaction originated.

f. The prospective lower tier participant further agrees by submitting this proposal that it will include this clause titled "Certification Regarding Debarment, Suspension, Ineligibility and Voluntary Exclusion-Lower Tier Covered Transaction," without modification, in all lower tier covered transactions and in all solicitations for lower tier covered transactions exceeding the \$25,000 threshold.

g. A participant in a covered transaction may rely upon a certification of a prospective participant in a lower tier covered transaction that is not debarred, suspended, ineligible, or voluntarily excluded from the covered transaction, unless it knows that the certification is erroneous. A participant is responsible for ensuring that its principals are not suspended, debarred, or otherwise ineligible to participate in covered transactions. To verify the eligibility of its principals, as well as the eligibility of any lower tier prospective participants, each participant may, but is not required to, check the Excluded Parties List System website (<https://www.epls.gov/>), which is compiled by the General Services Administration.

h. Nothing contained in the foregoing shall be construed to require establishment of a system of records in order to render in good faith the certification required by this clause. The knowledge and information of participant is not required to exceed that which is normally possessed by a prudent person in the ordinary course of business dealings.

i. Except for transactions authorized under paragraph e of these instructions, if a participant in a covered transaction knowingly enters into a lower tier covered transaction with a person who is suspended, debarred, ineligible, or voluntarily excluded from participation in this transaction, in addition to other remedies available to the Federal Government, the

department or agency with which this transaction originated may pursue available remedies, including suspension and/or debarment.

\* \* \* \* \*

**Certification Regarding Debarment, Suspension, Ineligibility and Voluntary Exclusion--Lower Tier Participants:**

1. The prospective lower tier participant certifies, by submission of this proposal, that neither it nor its principals is presently debarred, suspended, proposed for debarment, declared ineligible, or voluntarily excluded from participating in covered transactions by any Federal department or agency.

2. Where the prospective lower tier participant is unable to certify to any of the statements in this certification, such prospective participant shall attach an explanation to this proposal.

\* \* \* \* \*

**XI. CERTIFICATION REGARDING USE OF CONTRACT FUNDS FOR LOBBYING**

This provision is applicable to all Federal-aid construction contracts and to all related subcontracts which exceed \$100,000 (49 CFR 20).

1. The prospective participant certifies, by signing and submitting this bid or proposal, to the best of his or her knowledge and belief, that:

a. No Federal appropriated funds have been paid or will be paid, by or on behalf of the undersigned, to any person for influencing or attempting to influence an officer or employee of any Federal agency, a Member of Congress, an officer or employee of Congress, or an employee of a Member of Congress in connection with the awarding of any Federal contract, the making of any Federal grant, the making of any Federal loan, the entering into of any cooperative agreement, and the extension, continuation, renewal, amendment, or modification of any Federal contract, grant, loan, or cooperative agreement.

b. If any funds other than Federal appropriated funds have been paid or will be paid to any person for influencing or attempting to influence an officer or employee of any Federal agency, a Member of Congress, an officer or employee of Congress, or an employee of a Member of Congress in connection with this Federal contract, grant, loan, or cooperative agreement, the undersigned shall complete and submit Standard Form-LLL, "Disclosure Form to Report Lobbying," in accordance with its instructions.

2. This certification is a material representation of fact upon which reliance was placed when this transaction was made or entered into. Submission of this certification is a prerequisite for making or entering into this transaction imposed by 31 U.S.C. 1352. Any person who fails to file the required certification shall be subject to a civil penalty of not less than \$10,000 and not more than \$100,000 for each such failure.

3. The prospective participant also agrees by submitting its bid or proposal that the participant shall require that the language of this certification be included in all lower tier subcontracts, which exceed \$100,000 and that all such recipients shall certify and disclose accordingly.



**ATTACHMENT A - EMPLOYMENT AND MATERIALS  
PREFERENCE FOR APPALACHIAN DEVELOPMENT  
HIGHWAY SYSTEM OR APPALACHIAN LOCAL ACCESS  
ROAD CONTRACTS**

This provision is applicable to all Federal-aid projects funded under the Appalachian Regional Development Act of 1965.

1. During the performance of this contract, the contractor undertaking to do work which is, or reasonably may be, done as on-site work, shall give preference to qualified persons who regularly reside in the labor area as designated by the DOL wherein the contract work is situated, or the subregion, or the Appalachian counties of the State wherein the contract work is situated, except:

a. To the extent that qualified persons regularly residing in the area are not available.

b. For the reasonable needs of the contractor to employ supervisory or specially experienced personnel necessary to assure an efficient execution of the contract work.

c. For the obligation of the contractor to offer employment to present or former employees as the result of a lawful collective bargaining contract, provided that the number of nonresident persons employed under this subparagraph (1c) shall not exceed 20 percent of the total number of employees employed by the contractor on the contract work, except as provided in subparagraph (4) below.

2. The contractor shall place a job order with the State Employment Service indicating (a) the classifications of the laborers, mechanics and other employees required to perform the contract work, (b) the number of employees required in each classification, (c) the date on which the participant estimates such employees will be required, and (d) any other pertinent information required by the State Employment Service to complete the job order form. The job order may be placed with the State Employment Service in writing or by telephone. If during the course of the contract work, the information submitted by the contractor in the original job order is substantially modified, the participant shall promptly notify the State Employment Service.

3. The contractor shall give full consideration to all qualified job applicants referred to him by the State Employment Service. The contractor is not required to grant employment to any job applicants who, in his opinion, are not qualified to perform the classification of work required.

4. If, within one week following the placing of a job order by the contractor with the State Employment Service, the State Employment Service is unable to refer any qualified job applicants to the contractor, or less than the number requested, the State Employment Service will forward a certificate to the contractor indicating the unavailability of applicants. Such certificate shall be made a part of the contractor's permanent project records. Upon receipt of this certificate, the contractor may employ persons who do not normally reside in the labor area to fill positions covered by the certificate, notwithstanding the provisions of subparagraph (1c) above.

5. The provisions of 23 CFR 633.207(e) allow the contracting agency to provide a contractual preference for the use of mineral resource materials native to the Appalachian region.

6. The contractor shall include the provisions of Sections 1 through 4 of this Attachment A in every subcontract for work which is, or reasonably may be, done as on-site work.

**KENTUCKY TRANSPORTATION CABINET  
DEPARTMENT OF HIGHWAYS**

**EMPLOYMENT REQUIREMENTS  
RELATING TO  
NONDISCRIMINATION OF EMPLOYEES  
(APPLICABLE TO FEDERAL-AID SYSTEM CONTRACTS)**

**AN ACT OF THE KENTUCKY GENERAL ASSEMBLY  
TO PREVENT DISCRIMINATION IN EMPLOYMENT**

**KRS CHAPTER 344  
EFFECTIVE JUNE 16, 1972**

The contract on this project, in accordance with KRS Chapter 344, provides that during the performance of this contract, the contractor agrees as follows:

1. The contractor shall not fail or refuse to hire, or shall not discharge any individual, or otherwise discriminate against an individual with respect to his compensation, terms, conditions, or privileges of employment, because of such individual's race, color, religion, national origin, sex, disability or age (forty and above); or limit, segregate, or classify his employees in any way which would deprive or tend to deprive an individual of employment opportunities or otherwise adversely affect his status as an employee, because of such individual's race, color, religion, national origin, sex, disability or age forty (40) and over. The contractor agrees to post in conspicuous places, available to employees and applicants for employment, notices to be provided setting forth the provisions of this nondiscrimination clause.

2. The contractor shall not print or publish or cause to be printed or published a notice or advertisement relating to employment by such an employer or membership in or any classification or referral for employment by the employment agency, indicating any preference, limitation, specification, or discrimination, based on race, color, religion, national origin, sex, or age forty (40) and over, or because the person is a qualified individual with a disability, except that such a notice or advertisement may indicate a preference, limitation, or specification based on religion, national origin, sex, or age forty (40) and over, or because the person is a qualified individual with a disability, when religion, national origin, sex, or age forty (40) and over, or because the person is a qualified individual with a disability, is a bona fide occupational qualification for employment.

3. If the contractor is in control of apprenticeship or other training or retraining, including on-the-job training programs, he shall not discriminate against an individual because of his race, color, religion, national origin, sex, disability or age forty (40) and over, in admission to, or employment in any program established to provide apprenticeship or other training.

4. The contractor will send to each labor union or representative of workers with which he has a collective bargaining agreement or other contract or understanding, a notice to be provided advising the said labor union or workers' representative of the contractor's commitments under this section, and shall post copies of the notice in conspicuous places available to employees and applicants for employment. The contractor will take such action with respect to any subcontract or purchase order as the administering agency may direct as a means of enforcing such provisions, including sanctions for non-compliance.

Revised: January 25, 2017

### Standard Title VI/Non-Discrimination Assurances

During the performance of this contract, the contractor, for itself, its assignees, and successors in interest (hereinafter referred to as the "contractor") agrees as follows:

1. **Compliance with Regulations:** The contractor (hereinafter includes consultants) will comply with the Acts and the Regulations relative to Non-discrimination in Federally-assisted programs of the U.S. Department of Transportation, **Federal Highway Administration**, as they may be amended from time to time, which are herein incorporated by reference and made a part of this contract.
2. **Non-discrimination:** The contractor, with regard to the work performed by it during the contract, will not discriminate on the grounds of race, color, or national origin in the selection and retention of subcontractors, including procurements of materials and leases of equipment. The contractor will not participate directly or indirectly in the discrimination prohibited by the Acts and the Regulations, including employment practices when the contract covers any activity, project, or program set forth in Appendix B of 49 CFR Part 21.
3. **Solicitations for Subcontracts, Including Procurements of Materials and Equipment:** In all solicitations, either by competitive bidding, or negotiation made by the contractor for work to be performed under a subcontract, including procurements of materials, or leases of equipment, each potential subcontractor or supplier will be notified by the contractor of the contractor's obligations under this contract and the Acts and the Regulations relative to Non-discrimination on the grounds of race, color, or national origin.
4. **Information and Reports:** The contractor will provide all information and reports required by the Acts, the Regulations, and directives issued pursuant thereto and will permit access to its books, records, accounts, other sources of information, and its facilities as may be determined by the Recipient or the **Federal Highway Administration** to be pertinent to ascertain compliance with such Acts, Regulations, and instructions. Where any information required of a contractor is in the exclusive possession of another who fails or refuses to furnish the information, the contractor will so certify to the Recipient or the **Federal Highway Administration**, as appropriate, and will set forth what efforts it has made to obtain the information.
5. **Sanctions for Noncompliance:** In the event of a contractor's noncompliance with the Non-discrimination provisions of this contract, the Recipient will impose such contract sanctions as it or the **Federal Highway Administration** may determine to be appropriate, including, but not limited to:
  - a. withholding payments to the contractor under the contract until the contractor complies; and/or
  - b. cancelling, terminating, or suspending a contract, in whole or in part.
6. **Incorporation of Provisions:** The contractor will include the provisions of paragraphs one through six in every subcontract, including procurements of materials and leases of equipment, unless exempt by the Acts, the Regulations and directives issued pursuant thereto. The contractor will take action with respect to any subcontract or procurement as the Recipient or the **Federal Highway Administration** may direct as a means of enforcing such provisions including sanctions for noncompliance. Provided, that if the contractor becomes involved in, or is threatened with litigation by a subcontractor, or supplier because of such direction, the contractor may request the Recipient to enter into any litigation to protect the interests of the Recipient. In addition, the contractor may request the United States to enter into the litigation to protect the interests of the United States.

### Standard Title VI/Non-Discrimination Statutes and Authorities

During the performance of this contract, the contractor, for itself, its assignees, and successors in interest (hereinafter referred to as the “contractor”) agrees to comply with the following non-discrimination statutes and authorities; including but not limited to:

- Title VI of the Civil Rights Act of 1964 (42 U.S.C. § 2000d *et seq.*, 78 stat. 252), (prohibits discrimination on the basis of race, color, national origin); and 49 CFR Part 21;
- The Uniform Relocation Assistance and Real Property Acquisition Policies Act of 1970, (42 U.S.C. § 4601), (prohibits unfair treatment of persons displaced or whose property has been acquired because of Federal or Federal-aid programs and projects);
- Federal-Aid Highway Act of 1973, (23 U.S.C. § 324 *et seq.*), (prohibits discrimination on the basis of sex);
- Section 504 of the Rehabilitation Act of 1973, (29 U.S.C. § 794 *et seq.*), as amended, (prohibits discrimination on the basis of disability); and 49 CFR Part 27;
- The Age Discrimination Act of 1975, as amended, (42 U.S.C. § 6101 *et seq.*), (prohibits discrimination on the basis of age);
- Airport and Airway Improvement Act of 1982, (49 USC § 471, Section 47123), as amended, (prohibits discrimination based on race, creed, color, national origin, or sex);
- The Civil Rights Restoration Act of 1987, (PL 100-209), (Broadened the scope, coverage and applicability of Title VI of the Civil Rights Act of 1964, The Age Discrimination Act of 1975 and Section 504 of the Rehabilitation Act of 1973, by expanding the definition of the terms “programs or activities” to include all of the programs or activities of the Federal-aid recipients, sub-recipients and contractors, whether such programs or activities are Federally funded or not);
- Titles II and III of the Americans with Disabilities Act, which prohibit discrimination on the basis of disability in the operation of public entities, public and private transportation systems, places of public accommodation, and certain testing entities (42 U.S.C. §§ 12131 -- 12189) as implemented by Department of Transportation regulations at 49 C.F.R. parts 37 and 38;
- The Federal Aviation Administration’s Non-discrimination statute (49 U.S.C. § 47123) (prohibits discrimination on the basis of race, color, national origin, and sex);
- Executive Order 12898, Federal Actions to Address Environmental Justice in Minority Populations and Low-Income Populations, which ensures non-discrimination against minority populations by discouraging programs, policies, and activities with disproportionately high and adverse human health or environmental effects on minority and low-income populations;
- Executive Order 13166, Improving Access to Services for Persons with Limited English Proficiency, and resulting agency guidance, national origin discrimination includes discrimination because of limited English proficiency (LEP). To ensure compliance with Title VI, you must take reasonable steps to ensure that LEP persons have meaningful access to your programs (70 Fed. Reg. at 74087 to 74100);
- Title IX of the Education Amendments of 1972, as amended, which prohibits you from discriminating because of sex in education programs or activities (20 U.S.C. 1681 *et seq.*)

## EXECUTIVE BRANCH CODE OF ETHICS

In the 1992 regular legislative session, the General Assembly passed and Governor Brereton Jones signed Senate Bill 63 (codified as KRS 11A), the Executive Branch Code of Ethics, which states, in part:

KRS 11A.040 (7) provides:

No present or former public servant shall, within six (6) months following termination of his office or employment, accept employment, compensation, or other economic benefit from any person or business that contracts or does business with, or is regulated by, the state in matters in which he was directly involved during the last thirty-six (36) months of his tenure. This provision shall not prohibit an individual from returning to the same business, firm, occupation, or profession in which he was involved prior to taking office or beginning his term of employment, or for which he received, prior to his state employment, a professional degree or license, provided that, for a period of six (6) months, he personally refrains from working on any matter in which he was directly involved during the last thirty-six (36) months of his tenure in state government. This subsection shall not prohibit the performance of ministerial functions, including but not limited to filing tax returns, filing applications for permits or licenses, or filing incorporation papers, nor shall it prohibit the former officer or public servant from receiving public funds disbursed through entitlement programs.

KRS 11A.040 (9) states:

A former public servant shall not represent a person or business before a state agency in a matter in which the former public servant was directly involved during the last thirty-six (36) months of his tenure, for a period of one (1) year after the latter of:

- a) The date of leaving office or termination of employment; or
- b) The date the term of office expires to which the public servant was elected.

This law is intended to promote public confidence in the integrity of state government and to declare as public policy the idea that state employees should view their work as a public trust and not as a way to obtain private benefits.

If you have worked for the executive branch of state government within the past six months, you may be subject to the law's prohibitions. The law's applicability may be different if you hold elected office or are contemplating representation of another before a state agency.

Also, if you are affiliated with a firm which does business with the state and which employs former state executive-branch employees, you should be aware that the law may apply to them.

In case of doubt, the law permits you to request an advisory opinion from the Executive Branch Ethics Commission, 3 Fountain Place, Frankfort, Kentucky 40601; telephone (502) 564-7954.



Stone Mason.....	\$ 21.50	8.50
CARPENTER		
Carpenter.....	\$ 24.90	14.50
Piledriver.....	\$ 24.55	14.50

CEMENT MASON.....	\$ 21.25	8.50
-------------------	----------	------

ELECTRICIAN		
Electrician.....	\$ 29.36	10.55
Equipment Operator.....	\$ 26.90	10.31
Groundsman.....	\$ 17.79	8.51
Lineman.....	\$ 30.09	10.94

When workmen are required to work from bosum chairs, trusses, stacks, tanks, scaffolds, catwalks, radio and T.V. towers, structural steel (open, unprotected, unfloored raw steel), and bridges or similar hazardous locations where workmen are subject to fall, except where using JLG's and bucket trucks up to 75 feet: Add 25% to workman's base rate for 50 to 75 feet, and add 50% to workman's base rate for over 75 feet.

IRONWORKER.....	\$ 27.56	20.57
-----------------	----------	-------

LABORER		
Group 1.....	\$ 21.80	12.36
Group 2.....	\$ 22.05	12.36
Group 3.....	\$ 22.10	12.36
Group 4.....	\$ 22.70	12.36

GROUP 1: Aging and Curing of Concrete (Any Mode or Method), Asbestos Abatement Worker, Asphalt Plant Laborers, Asphalt Laborers, Batch Truck Dumpers, Carpenter Tenders, Cement Mason Tenders, Cleaning of Machines, Concrete Laborers, Demolition Laborers, Dredging Laborers, Drill Tender, Environmental Laborer - Nuclear, Radiation, Toxic and Hazardous Waste - Level D, Flagmen, Grade Checkers, All Hand Digging and Hand Back Filling, Highway Marker Placers, Landscaping Laborers, Mesh Handlers and Placers, Puddler, Railroad Laborers, Rip-rap and Grouters, Right of Way Laborers, Sign, Guard Rail and Fence Installers (All Types), Signalmen, Sound Barrier Installer, Storm and Sanitary Sewer Laborers, Swampers, Truck Spotters and Dumpers, Wrecking of Concrete Forms, General Cleanup

GROUP 2: Batter Board Men (Sanitary and Storm Sewer), Brickmason Tenders, Mortar Mixer Operator, Scaffold Builders, Burner and Welder, Bushammers, Chain Saw Operator, Concrete Saw Operators, Deckhand Scow Man, Dry Cement Handlers, Environmental Laborers - Nuclear, Radiation, Toxic and Hazardous Waste - Level C, Forklift Operators for Masonry, Form Setters, Green Concrete Cutting, Hand Operated Grouter and Grinder Machine Operator, Jack Hammers, Lead Paint Abatement, Pavement Breakers, Paving Joint Machine, Pipe Layers - Laser Operators (Non-metallic), Plastic Pipe Fusion, Power Driven Georgia Buggy and Wheel Barrow, Power Post Hole Diggers, Precast Manhole Setters, Walk-behind Tampers, Walk-behind Trenchers, Sand Blasters, Concrete Chippers, Surface Grinders, Vibrator Operators, Wagon Drillers

GROUP 3: Air Track Driller (All Types), Asphalt Luteman and Rakers, Gunnite Nozzleman, Gunnite Operators and Mixers, Grout

Pump Operator, Powderman and Blaster, Side Rail Setters, Rail Paved Ditches, Screw Operators, Tunnel Laborers (Free Air), Water Blasters

GROUP 4: Caisson Workers (Free Air), Cement Finishers, Environmental Laborer - Nuclear, Radiation, Toxic and Hazardous Waste - Level A and B, miners and Drillers (Free Air), Tunnel Blasters, and Tunnel Mockers (Free Air), Directional and Horizontal Boring, Air Track Drillers (All Types), Powder Man and Blasters, Troxler and Concrete Tester if Laborer is Utilized

PAINTER

All Excluding Bridges.....	\$ 19.92	9.57
Bridges.....	\$ 23.92	10.07

PLUMBER.....\$ 22.52 7.80

POWER EQUIPMENT OPERATOR:

Group 1.....	\$ 29.95	14.40
Group 2.....	\$ 29.95	14.40
Group 3.....	\$ 27.26	14.40
Group 4.....	\$ 26.96	14.40

GROUP 1: Auto Patrol, Batch Plant, Bituminous Paver, Cable-Way, Clamshell, Concrete Mixer (21 cu ft or over), Concrete Pump, Crane, Crusher Plant, Derrick, Derrick Boat, Ditching and Trenching Machine, Dragline, Dredge Engineer, Elevator (regardless of ownership when used for hoisting any building material), Elevating Grader and all types of Loaders, Hoe-type Machine, Hoisting Engine, Locomotive, LeTourneau or Carry-all Scoop, Bulldozer, Mechanic, Orangepeel Bucket, Piledriver, Power Blade, Roller (Bituminous), Roller (Earth), Roller (Rock), Scarifier, Shovel, Tractor Shovel, Truck Crane, Well Point, Winch Truck, Push Dozer, Grout Pump, High Lift, Fork Lift (regardless of lift height), all types of Boom Cats, Multiple Operator, Core Drill, Tow or Push Boat, A-Frame Winch Truck, Concrete Paver, Grade-All, Hoist, Hyster, Material Pump, Pumpcrete, Ross Carrier, Sheepfoot, Sideboom, Throttle-Valve Man, Rotary Drill, Power Generator, Mucking Machine, Rock Spreader attached to Equipment, Scoopmobile, KeCal Loader, Tower Cranes, (French, German and other types), Hydrocrane, Tugger, Backfiller Gurries, Self-propelled Compactor, Self-Contained Hydraulic Percussion Drill

GROUP 2: All Air Compressors (200 cu ft/min or greater), Bituminous Mixer, Concrete Mixer (21 cu. ft. or over), Welding Machine, Form Grader, Tractor (50 hp and over), Bull Float, Finish Machine, Outboard Motor Boat, Brakeman, Mechanic Tender, Whirly Oiler, Tract-air, Road Widening Trencher, Articulating Trucks

GROUP 3: Greaser on Grease Facilities servicing Heavy Equipment

GROUP 4: Bituminous Distributor, Cement Gun, Conveyor, Mud Jack, Paving Joint Machine, Pump, Tamping Machine, Tractor (under 50 hp), Vibrator, Oiler, Air Compressor (under 200 cu ft per minute), Concrete Saw, Burlap and Curing Machine, Hydro Seeder, Power Form Handling Equipment, Deckhand Oiler, Hydraulic Post Driver



SHEET METAL WORKER.....	\$ 20.40	7.80
TRUCK DRIVER		
Driver (3 Tons and Over), Driver (Truck Mounted Rotary Drill).....	\$ 23.74	14.50
Driver (3 Tons and Under), Tire Changer and Truck Mechanic Tender.....	\$ 23.53	14.50
Driver (Semi-Trailer or Pole Trailer), Driver (Dump Truck, Tandem Axle), Driver of Distributor.....	\$ 23.40	14.50
Driver on Mixer Trucks (All Types).....	\$ 23.45	14.50
Driver on Pavement Breakers.	\$ 23.55	14.50
Driver, Euclid and Other Heavy Earth Moving Equipment and Low Boy.....	\$ 24.31	14.50
Driver, Winch Truck and A- Frame when used in Transporting Materials.....	\$ 23.30	14.50
Greaser on Greasing Facilities.....	\$ 24.40	14.50
Truck Mechanic.....	\$ 23.50	14.50
Truck Tender and Warehouseman.....	\$ 23.20	14.50

-----  
WELDERS - Receive rate prescribed for craft performing  
operation to which welding is incidental.

=====  
Note: Executive Order (EO) 13706, Establishing Paid Sick Leave  
for Federal Contractors applies to all contracts subject to the  
Davis-Bacon Act for which the contract is awarded (and any  
solicitation was issued) on or after January 1, 2017. If this  
contract is covered by the EO, the contractor must provide  
employees with 1 hour of paid sick leave for every 30 hours  
they work, up to 56 hours of paid sick leave each year.  
Employees must be permitted to use paid sick leave for their  
own illness, injury or other health-related needs, including  
preventive care; to assist a family member (or person who is  
like family to the employee) who is ill, injured, or has other  
health-related needs, including preventive care; or for reasons  
resulting from, or to assist a family member (or person who is  
like family to the employee) who is a victim of, domestic  
violence, sexual assault, or stalking. Additional information  
on contractor requirements and worker protections under the EO  
is available at [www.dol.gov/whd/govcontracts](http://www.dol.gov/whd/govcontracts).

Unlisted classifications needed for work not included within  
the scope of the classifications listed may be added after  
award only as provided in the labor standards contract clauses  
(29CFR 5.5 (a) (1) (ii)).

The body of each wage determination lists the classification and wage rates that have been found to be prevailing for the cited type(s) of construction in the area covered by the wage determination. The classifications are listed in alphabetical order of "identifiers" that indicate whether the particular rate is a union rate (current union negotiated rate for local), a survey rate (weighted average rate) or a union average rate (weighted union average rate).

#### Union Rate Identifiers

A four letter classification abbreviation identifier enclosed in dotted lines beginning with characters other than "SU" or "UAVG" denotes that the union classification and rate were prevailing for that classification in the survey. Example: PLUM0198-005 07/01/2014. PLUM is an abbreviation identifier of the union which prevailed in the survey for this classification, which in this example would be Plumbers. 0198 indicates the local union number or district council number where applicable, i.e., Plumbers Local 0198. The next number, 005 in the example, is an internal number used in processing the wage determination. 07/01/2014 is the effective date of the most current negotiated rate, which in this example is July 1, 2014.

Union prevailing wage rates are updated to reflect all rate changes in the collective bargaining agreement (CBA) governing this classification and rate.

#### Survey Rate Identifiers

Classifications listed under the "SU" identifier indicate that no one rate prevailed for this classification in the survey and the published rate is derived by computing a weighted average rate based on all the rates reported in the survey for that classification. As this weighted average rate includes all rates reported in the survey, it may include both union and non-union rates. Example: SULA2012-007 5/13/2014. SU indicates the rates are survey rates based on a weighted average calculation of rates and are not majority rates. LA indicates the State of Louisiana. 2012 is the year of survey on which these classifications and rates are based. The next number, 007 in the example, is an internal number used in producing the wage determination. 5/13/2014 indicates the survey completion date for the classifications and rates under that identifier.

Survey wage rates are not updated and remain in effect until a new survey is conducted.

#### Union Average Rate Identifiers

Classification(s) listed under the UAVG identifier indicate that no single majority rate prevailed for those classifications; however, 100% of the data reported for the classifications was union data. EXAMPLE: UAVG-OH-0010 08/29/2014. UAVG indicates that the rate is a weighted union average rate. OH indicates the state. The next number, 0010 in the example, is an internal number used in producing the wage

determination. 08/29/2014 indicates the survey completion date for the classifications and rates under that identifier.

A UAVG rate will be updated once a year, usually in January of each year, to reflect a weighted average of the current negotiated/CBA rate of the union locals from which the rate is based.

---

WAGE DETERMINATION APPEALS PROCESS

1.) Has there been an initial decision in the matter? This can be:

- \* an existing published wage determination
- \* a survey underlying a wage determination
- \* a Wage and Hour Division letter setting forth a position on a wage determination matter
- \* a conformance (additional classification and rate) ruling

On survey related matters, initial contact, including requests for summaries of surveys, should be with the Wage and Hour Regional Office for the area in which the survey was conducted because those Regional Offices have responsibility for the Davis-Bacon survey program. If the response from this initial contact is not satisfactory, then the process described in 2.) and 3.) should be followed.

With regard to any other matter not yet ripe for the formal process described here, initial contact should be with the Branch of Construction Wage Determinations. Write to:

Branch of Construction Wage Determinations  
Wage and Hour Division  
U.S. Department of Labor  
200 Constitution Avenue, N.W.  
Washington, DC 20210

2.) If the answer to the question in 1.) is yes, then an interested party (those affected by the action) can request review and reconsideration from the Wage and Hour Administrator (See 29 CFR Part 1.8 and 29 CFR Part 7). Write to:

Wage and Hour Administrator  
U.S. Department of Labor  
200 Constitution Avenue, N.W.  
Washington, DC 20210

The request should be accompanied by a full statement of the interested party's position and by any information (wage payment data, project description, area practice material, etc.) that the requestor considers relevant to the issue.

3.) If the decision of the Administrator is not favorable, an interested party may appeal directly to the Administrative Review Board (formerly the Wage Appeals Board). Write to:

Administrative Review Board  
U.S. Department of Labor  
200 Constitution Avenue, N.W.  
Washington, DC 20210

4.) All decisions by the Administrative Review Board are final.

=====  
END OF GENERAL DECISION

Fringe benefit amounts are applicable for all hours worked except when otherwise noted.

No laborer, workman or mechanic shall be paid at a rate less than that of a Journeyman except those classified as bona fide apprentices.

Apprentices or trainees shall be permitted to work as such subject to Administrative Regulations adopted by the Commissioner of Workplace Standards. Copies of these regulations will be furnished upon request from any interested person.

Before using apprentices on the job the contractor shall present to the Contracting Officer written evidence of registration of such employees in a program of a State apprenticeship and training agency approved and recognized by the U. S. Bureau of Apprenticeship and Training. In the absence of such a State agency, the contractor shall submit evidence of approval and registration by the U. S. Bureau of Apprenticeship and Training.

The contractor shall submit to the Contracting Officer, written evidence of the established apprenticeship-journeyman ratios and wage rates in the project area, which will be the basis for establishing such ratios and rates for the project under the applicable contract provisions.

**TO: EMPLOYERS/EMPLOYEES**

**PREVAILING WAGE SCHEDULE:**

**The wages indicated on this wage schedule are the least permitted to be paid for the occupations indicated. When an employee works in more than one classification, the employer must record the number of hours worked in each classification at the prescribed hourly base rate.**

**OVERTIME:**

**Overtime is to be paid after an employee works eight (8) hours a day or forty (40) hours a week, whichever gives the employee the greater wages. At least time and one-half the base rate is required for all overtime. A laborer, workman or mechanic and an employer may enter into a written agreement or a collective bargaining agreement to work more than eight (8) hours a calendar day but not more than ten (10) hours a calendar day for the straight time hourly rate. Wage violations or questions should be directed to the designated Engineer or the undersigned.**

Director  
Division of Construction Procurement  
Frankfort, Kentucky 40622  
502-564-3500

General Decision Number: KY190038 01/04/2019 KY38

Superseded General Decision Number: KY20180100

State: Kentucky

Construction Type: Highway

Counties: Anderson, Bath, Bourbon, Boyd, Boyle, Bracken, Breckinridge, Bullitt, Carroll, Carter, Clark, Elliott, Fayette, Fleming, Franklin, Gallatin, Grant, Grayson, Greenup, Hardin, Harrison, Henry, Jefferson, Jessamine, Larue, Lewis, Madison, Marion, Mason, Meade, Mercer, Montgomery, Nelson, Nicholas, Oldham, Owen, Robertson, Rowan, Scott, Shelby, Spencer, Trimble, Washington and Woodford Counties in Kentucky.

HIGHWAY CONSTRUCTION PROJECTS (excluding tunnels, building structures in rest area projects & railroad construction; bascule, suspension & spandrel arch bridges designed for commercial navigation, bridges involving marine construction; and other major bridges).

Note: Under Executive Order (EO) 13658, an hourly minimum wage of \$10.60 for calendar year 2019 applies to all contracts subject to the Davis-Bacon Act for which the contract is awarded (and any solicitation was issued) on or after January 1, 2015. If this contract is covered by the EO, the contractor must pay all workers in any classification listed on this wage determination at least \$10.60 per hour (or the applicable wage rate listed on this wage determination, if it is higher) for all hours spent performing on the contract in calendar year 2019. If this contract is covered by the EO and a classification considered necessary for performance of work on the contract does not appear on this wage determination, the contractor must pay workers in that classification at least the wage rate determined through the conformance process set forth in 29 CFR 5.5(a)(1)(ii) (or the EO minimum wage rate, if it is higher than the conformed wage rate). The EO minimum wage rate will be adjusted annually. Please note that this EO applies to the above-mentioned types of contracts entered into by the federal government that are subject to the Davis-Bacon Act itself, but it does not apply to contracts subject only to the Davis-Bacon Related Acts, including those set forth at 29 CFR 5.1(a)(2)-(60). Additional information on contractor requirements and worker protections under the EO is available at [www.dol.gov/whd/govcontracts](http://www.dol.gov/whd/govcontracts).

Modification Number      Publication Date  
0                              01/04/2019

BRIN0004-003 06/01/2017

BRECKENRIDGE COUNTY

Rates                      Fringes

BRICKLAYER.....\$ 26.80 12.38

-----  
BRKY0001-005 06/01/2017

BULLITT, CARROLL, GRAYSON, HARDIN, HENRY, JEFFERSON, LARUE,  
MARION, MEADE, NELSON, OLDHAM, SHELBY, SPENCER, & TRIMBLE  
COUNTIES:

Rates Fringes

BRICKLAYER.....\$ 26.80 12.38

-----  
BRKY0002-006 06/01/2017

BRACKEN, GALLATIN, GRANT, MASON & ROBERTSON COUNTIES:

Rates Fringes

BRICKLAYER.....\$ 27.81 13.01

-----  
BRKY0007-004 06/01/2017

BOYD, CARTER, ELLIOT, FLEMING, GREENUP, LEWIS & ROWAN COUNTIES:

Rates Fringes

BRICKLAYER.....\$ 32.98 19.02

-----  
BRKY0017-004 06/01/2017

ANDERSON, BATH, BOURBON, BOYLE, CLARK, FAYETTE, FRANKLIN,  
HARRISON, JESSAMINE, MADISON, MERCER, MONTGOMERY, NICHOLAS,  
OWEN, SCOTT, WASHINGTON & WOODFORD COUNTIES:

Rates Fringes

BRICKLAYER.....\$ 26.47 12.76

-----  
CARP0064-001 05/01/2015

Rates Fringes

CARPENTER.....\$ 27.50 16.06  
Diver.....\$ 41.63 16.06  
PILEDRIVERMAN.....\$ 27.75 16.06

-----  
ELEC0212-008 06/04/2018

BRACKEN, GALLATIN and GRANT COUNTIES

Rates Fringes

ELECTRICIAN.....\$ 28.39 18.98

-----  
ELEC0212-014 11/27/2017

BRACKEN, GALLATIN & GRANT COUNTIES:

	Rates	Fringes
Sound & Communication Technician.....	\$ 23.55	11.26
-----		
ELEC0317-012 06/01/2018		

BOYD, CARTER, ELLIOT & ROWAN COUNTIES:

	Rates	Fringes
ELECTRICIAN (Wiremen) Cable Splicer.....	\$ 32.68	18.13
Electrician.....	\$ 33.75	20.03
-----		
ELEC0369-007 05/30/2018		

ANDERSON, BATH, BOURBON, BOYLE, BRECKINRIDGE, BULLITT, CARROLL,  
 CLARK, FAYETTE, FRAONKLIN, GRAYSON, HARDIN, HARRISON, HENRY,  
 JEFFERSON, JESSAMINE, LARUE, MADISON, MARION, MEADE, MERCER,  
 MONTGOMERY, NELSON, NICHOLAS, OLDHAM, OWEN, ROBERTSON, SCOTT,  
 SHELBY, SPENCER, TRIMBLE, WASHINGTON, & WOODFORD COUNTIES:

	Rates	Fringes
ELECTRICIAN.....	\$ 31.66	17.01
-----		
ELEC0575-002 05/28/2018		

FLEMING, GREENUP, LEWIS & MASON COUNTIES:

	Rates	Fringes
ELECTRICIAN.....	\$ 32.45	16.43
-----		
ENGI0181-018 07/01/2017		

	Rates	Fringes
POWER EQUIPMENT OPERATOR GROUP 1.....	\$ 31.95	15.15
GROUP 2.....	\$ 29.09	15.15
GROUP 3.....	\$ 29.54	15.15
GROUP 4.....	\$ 28.77	15.15

OPERATING ENGINEER CLASSIFICATIONS

GROUP 1 - A-Frame Winch Truck; Auto Patrol; Backfiller;  
 Batcher Plant; Bituminous Paver; Bituminous Transfer  
 Machine; Boom Cat; Bulldozer; Mechanic; Cableway; Carry-All  
 Scoop; Carry Deck Crane; Central Compressor Plant; Cherry  
 Picker; Clamshell; Concrete Mixer (21 cu. ft. or Over);  
 Concrete Paver; Truck-Mounted Concrete Pump; Core Drill;  
 Crane; Crusher Plant; Derrick; Derrick Boat; Ditching &  
 Trenching Machine; Dragline; Dredge Operator; Dredge  
 Engineer; Elevating Grader & Loaders; Grade-All; Gurries;  
 Heavy Equipment Robotics Operator/Mechanic; High Lift;  
 Hoe-Type Machine; Hoist (Two or More Drums); Hoisting



Engine (Two or More Drums); Horizontal Directional Drill Operator; Hydrocrane; Hyster; KeCal Loader; LeTourneau; Locomotive; Mechanic; Mechanically Operated Laser Screed; Mechanic Welder; Mucking Machine; Motor Scraper; Orangepeel Bucket; Overhead Crane; Piledriver; Power Blade; Pumpcrete; Push Dozer; Rock Spreader, attached to equipment; Rotary Drill; Roller (Bituminous); Rough Terrain Crane; Scarifier; Scoopmobile; Shovel; Side Boom; Subgrader; Tailboom; Telescoping Type Forklift; Tow or Push Boat; Tower Crane (French, German & other types); Tractor Shovel; Truck Crane; Tunnel Mining Machines, including Moles, Shields or similar types of Tunnel Mining Equipment

GROUP 2 - Air Compressor (Over 900 cu. ft. per min.); Bituminous Mixer; Boom Type Tamping Machine; Bull Float; Concrete Mixer (Under 21 cu. ft.); Dredge Engineer; Electric Vibrator; Compactor/Self-Propelled Compactor; Elevator (One Drum or Buck Hoist); Elevator (When used to Hoist Building Material); Finish Machine; Firemen & Hoist (One Drum); Flexplane; Forklift (Regardless of Lift Height); Form Grader; Joint Sealing Machine; Outboard Motor Boat; Power Sweeper (Riding Type); Roller (Rock); Ross Carrier; Skid Mounted or Trailer Mounted Concrete Pump; Skid Steer Machine with all Attachments; Switchman or Brakeman; Throttle Valve Person; Tractair & Road Widening Trencher; Tractor (50 H.P. or Over); Truck Crane Oiler; Tugger; Welding Machine; Well Points; & Whirley Oiler

GROUP 3 - All Off Road Material Handling Equipment, including Articulating Dump Trucks; Greaser on Grease Facilities servicing Heavy Equipment

GROUP 4 - Bituminous Distributor; Burlap & Curing Machine; Cement Gun; Concrete Saw; Conveyor; Deckhand Oiler; Grout Pump; Hydraulic Post Driver; Hydro Seeder; Mud Jack; Oiler; Paving Joint Machine; Power Form Handling Equipment; Pump; Roller (Earth); Steerman; Tamping Machine; Tractor (Under 50 H.P.); & Vibrator

CRANES - with booms 150 ft. & Over (Including JIB), and where the length of the boom in combination with the length of the piling leads equals or exceeds 150 ft. - \$1.00 over Group 1 rate

EMPLOYEES ASSIGNED TO WORK BELOW GROUND LEVEL ARE TO BE PAID 10% ABOVE BASIC WAGE RATE. THIS DOES NOT APPLY TO OPEN CUT WORK.

-----  
IRON0044-009 06/01/2018

BRACKEN, GALLATIN, GRANT, HARRISON, ROBERTSON,  
BOURBON (Northern third, including Townships of Jackson, Millersburg, Ruddel Mills & Shawhan);  
CARROLL (Eastern third, including the Township of Ghent);  
FLEMING (Western part, excluding Townships of Beechburg, Colfax, Elizaville, Flemingsburg, Flemingsburg Junction, Foxport, Grange City, Hillsboro, Hilltop, Mount Carmel, Muses Mills, Nepton, Pecksridge, Plummers Landing, Plummers Mill, Poplar Plains, Ringos Mills, Tilton & Wallingford);

MASON (Western two-thirds, including Townships of Dover, Lewisburg, Mays Lick, Maysville, Minerva, Moranburg, Murphysville, Ripley, Sardis, Shannon, South Ripley & Washington);  
 NICHOLAS (Townships of Barefoot, Barterville, Carlisle, Ellisville, Headquarters, Henryville, Morningglory, Myers & Oakland Mills);  
 OWEN (Townships of Beechwood, Bromley, Fairbanks, Holbrook, Jonesville, Long Ridge, Lusby's Mill, New, New Columbus, New Liberty, Owenton, Poplar Grove, Rockdale, Sanders, Teresita & Wheatley);  
 SCOTT (Northern two-thirds, including Townships of Biddle, Davis, Delaplain, Elmville, Longlick, Muddy Ford, Oxford, Rogers Gap, Sadieville, Skinnersburg & Stonewall)

	Rates	Fringes
IRONWORKER		
Fence Erector.....	\$ 26.76	21.20
Structural.....	\$ 28.17	21.20

-----  
 IRON0070-006 06/01/2018

ANDERSON, BOYLE, BRECKINRIDGE, BULLITT, FAYETTE, FRANKLIN, GRAYSON, HARDIN, HENRY, JEFFERSON, JESSAMINE, LARUE, MADISON, MARION, MEADE, MERCER, NELSON, OLDHAM, SHELBY, SPENCER, TRIMBLE, WASHINGTON & WOODFORD  
 BOURBON (Southern two-thirds, including Townships of Austerlity, Centerville, Clintonville, Elizabeth, Hutchison, Littlerock, North Middletown & Paris);  
 CARROLL (Western two-thirds, including Townships of Carrollton, Easterday, English, Locust, Louis, Prestonville & Worthville);  
 CLARK (Western two-thirds, including Townships of Becknerville, Flanagan, Ford, Pine Grove, Winchester & Wyandotte);  
 OWEN (Eastern eighth, including Townships of Glenmary, Gratz, Monterey, Perry Park & Tacketts Mill);  
 SCOTT (Southern third, including Townships of Georgetown, Great Crossing, Newtown, Stampling Ground & Woodlake);

	Rates	Fringes
IRONWORKER.....	\$ 28.79	22.50

-----  
 IRON0769-007 06/01/2018

BATH, BOYD, CARTER, ELLIOTT, GREENUP, LEWIS, MONTGOMERY & ROWAN  
 CLARK (Eastern third, including townships of Bloomingdale, Hunt, Indian Fields, Kiddville, Loglick, Rightangele & Thomson);  
 FLEMING (Townships of Beechburg, Colfax, Elizaville, Flemingsburg, Flemingsburg Junction, Foxport, Grange City, Hillsboro, Hilltop, Mount Carmel, Muses Mills, Nepton, Pecksville, Plummers Landing, Plummers Mill, Poplar Plains, Ringos Mills, Tilton & Wallingford);  
 MASON (Eastern third, including Townships of Helena, Marshall, Orangeburg, Plumville & Springdale);  
 NICHOLAS (Eastern eighth, including the Township of Moorefield Sprout)

	Rates	Fringes
IRONWORKER		
ZONE 1.....	\$ 31.67	25.27
ZONE 2.....	\$ 31.67	25.27
ZONE 3.....	\$ 31.67	25.27

ZONE 1 - (no base rate increase) Up to 10 mile radius of Union Hall, 1643 Greenup Ave, Ashland, KY.

ZONE 2 - (add \$0.40 per hour to base rate) 10 to 50 mile radius of Union Hall, 1643 Greenup Ave, Ashland, KY.

ZONE 3 - (add \$2.00 per hour to base rate) 50 mile radius & over of Union Hall, 1643 Greenup Ave, Ashland, KY.

-----  
LABO0189-003 07/01/2018

BATH, BOURBON, BOYD, BOYLE, BRACKEN, CARTER, CLARK, ELLIOTT, FAYETTE, FLEMING, FRANKLIN, GALLATIN, GRANT, GREENUP, HARRISON, JESSAMINE, LEWIS, MADISON, MASON, MERCER, MONTGOMERY, NICHOLAS, OWEN, ROBERTSON, ROWAN, SCOTT, & WOOLFORD COUNTIES

	Rates	Fringes
Laborers:		
GROUP 1.....	\$ 23.07	14.21
GROUP 2.....	\$ 23.32	14.21
GROUP 3.....	\$ 23.37	14.21
GROUP 4.....	\$ 23.97	14.21

LABORERS CLASSIFICATIONS

GROUP 1 - Aging & Curing of Concrete; Asbestos Abatement Worker; Asphalt Plant; Asphalt; Batch Truck Dump; Carpenter Tender; Cement Mason Tender; Cleaning of Machines; Concrete; Demolition; Dredging; Environmental - Nuclear, Radiation, Toxic & Hazardous Waste - Level D; Flagperson; Grade Checker; Hand Digging & Hand Back Filling; Highway Marker Placer; Landscaping, Mesh Handler & Placer; Puddler; Railroad; Rip-rap & Grouter; Right-of-Way; Sign, Guard Rail & Fence Installer; Signal Person; Sound Barrier Installer; Storm & Sanitary Sewer; Swamper; Truck Spotter & Dumper; Wrecking of Concrete Forms; General Cleanup

GROUP 2 - Batter Board Man (Sanitary & Storm Sewer); Brickmason Tender; Mortar Mixer Operator; Scaffold Builder; Burner & Welder; Bushhammer; Chain Saw Operator; Concrete Saw Operator; Deckhand Scow Man; Dry Cement Handler; Environmental - Nuclear, Radiation, Toxic & Hazardous Waste - Level C; Forklift Operator for Masonary; Form Setter; Green Concrete Cutting; Hand Operated Grouter & Grinder Machine Operator; Jackhammer; Pavement Breaker; Paving Joint Machine; Pipelayer; Plastic Pipe Fusion; Power Driven Georgia Buggy & Wheel Barrow; Power Post Hole Digger; Precast Manhole Setter; Walk-Behind Tamper; Walk-Behind Trencher; Sand Blaster; Concrete Chipper; Surface Grinder;

Vibrator Operator; Wagon Driller

GROUP 3 - Asphalt Luteman & Raker; Gunnite Nozzleman;  
Gunnite Operator & Mixer; Grout Pump Operator; Side Rail  
Setter; Rail Paved Ditches; Screw Operator; Tunnel (Free  
Air); Water Blaster

GROUP 4 - Caisson Worker (Free Air); Cement Finisher;  
Environmental - Nuclear, Radiation, Toxic & Hazardous Waste  
- Levels A & B; Miner & Driller (Free Air); Tunnel Blaster;  
& Tunnel Mucker (Free Air); Directional & Horizontal  
Boring; Air Track Drillers (All Types); Powdermen &  
Blasters; Troxler & Concrete Tester if Laborer is Utilized

-----  
LAB00189-008 07/01/2018

ANDERSON, BULLITT, CARROLL, HARDIN, HENRY, JEFFERSON, LARUE,  
MARION, MEADE, NELSON, OLDHAM, SHELBY, SPENCER, TRIMBLE &  
WASHINGTON COUNTIES

Rates Fringes

Laborers:

GROUP 1.....	\$ 23.07	14.21
GROUP 2.....	\$ 23.32	14.21
GROUP 3.....	\$ 23.37	14.21
GROUP 4.....	\$ 23.97	14.21

LABORERS CLASSIFICATIONS

GROUP 1 - Aging & Curing of Concrete; Asbestos Abatement  
Worker; Asphalt Plant; Asphalt; Batch Truck Dump; Carpenter  
Tender; Cement Mason Tender; Cleaning of Machines;  
Concrete; Demolition; Dredging; Environmental - Nuclear,  
Radiation, Toxic & Hazardous Waste - Level D; Flagperson;  
Grade Checker; Hand Digging & Hand Back Filling; Highway  
Marker Placer; Landscaping, Mesh Handler & Placer; Puddler;  
Railroad; Rip-rap & Grouter; Right-of-Way; Sign, Guard Rail  
& Fence Installer; Signal Person; Sound Barrier Installer;  
Storm & Sanitary Sewer; Swamper; Truck Spotter & Dumper;  
Wrecking of Concrete Forms; General Cleanup

GROUP 2 - Batter Board Man (Sanitary & Storm Sewer);  
Brickmason Tender; Mortar Mixer Operator; Scaffold Builder;  
Burner & Welder; Bushhammer; Chain Saw Operator; Concrete  
Saw Operator; Deckhand Scow Man; Dry Cement Handler;  
Environmental - Nuclear, Radiation, Toxic & Hazardous Waste  
- Level C; Forklift Operator for Masonary; Form Setter;  
Green Concrete Cutting; Hand Operated Grouter & Grinder  
Machine Operator; Jackhammer; Pavement Breaker; Paving  
Joint Machine; Pipelayer; Plastic Pipe Fusion; Power Driven  
Georgia Buggy & Wheel Barrow; Power Post Hole Digger;  
Precast Manhole Setter; Walk-Behind Tamper; Walk-Behind  
Trencher; Sand Blaster; Concrete Chipper; Surface Grinder;  
Vibrator Operator; Wagon Driller

GROUP 3 - Asphalt Luteman & Raker; Gunnite Nozzleman;  
Gunnite Operator & Mixer; Grout Pump Operator; Side Rail

Setter; Rail Paved Ditches; Screw Operator; Tunnel (Free Air); Water Blaster

GROUP 4 - Caisson Worker (Free Air); Cement Finisher; Environmental - Nuclear, Radiation, Toxic & Hazardous Waste - Levels A & B; Miner & Driller (Free Air); Tunnel Blaster; & Tunnel Mucker (Free Air); Directional & Horizontal Boring; Air Track Drillers (All Types); Powdermen & Blasters; Troxler & Concrete Tester if Laborer is Utilized

-----  
LABO0189-009 07/01/2018

BRECKINRIDGE & GRAYSON COUNTIES

Rates Fringes

Laborers:

GROUP 1.....	\$ 23.07	14.21
GROUP 2.....	\$ 23.32	14.21
GROUP 3.....	\$ 23.37	14.21
GROUP 4.....	\$ 23.97	14.21

LABORERS CLASSIFICATIONS

GROUP 1 - Aging & Curing of Concrete; Asbestos Abatement Worker; Asphalt Plant; Asphalt; Batch Truck Dump; Carpenter Tender; Cement Mason Tender; Cleaning of Machines; Concrete; Demolition; Dredging; Environmental - Nuclear, Radiation, Toxic & Hazardous Waste - Level D; Flagperson; Grade Checker; Hand Digging & Hand Back Filling; Highway Marker Placer; Landscaping, Mesh Handler & Placer; Puddler; Railroad; Rip-rap & Grouter; Right-of-Way; Sign, Guard Rail & Fence Installer; Signal Person; Sound Barrier Installer; Storm & Sanitary Sewer; Swamper; Truck Spotter & Dumper; Wrecking of Concrete Forms; General Cleanup

GROUP 2 - Batter Board Man (Sanitary & Storm Sewer); Brickmason Tender; Mortar Mixer Operator; Scaffold Builder; Burner & Welder; Bushhammer; Chain Saw Operator; Concrete Saw Operator; Deckhand Scow Man; Dry Cement Handler; Environmental - Nuclear, Radiation, Toxic & Hazardous Waste - Level C; Forklift Operator for Masonary; Form Setter; Green Concrete Cutting; Hand Operated Grouter & Grinder Machine Operator; Jackhammer; Pavement Breaker; Paving Joint Machine; Pipelayer; Plastic Pipe Fusion; Power Driven Georgia Buggy & Wheel Barrow; Power Post Hole Digger; Precast Manhole Setter; Walk-Behind Tamper; Walk-Behind Trencher; Sand Blaster; Concrete Chipper; Surface Grinder; Vibrator Operator; Wagon Driller

GROUP 3 - Asphalt Luteman & Raker; Gunnite Nozzleman; Gunnite Operator & Mixer; Grout Pump Operator; Side Rail Setter; Rail Paved Ditches; Screw Operator; Tunnel (Free Air); Water Blaster

GROUP 4 - Caisson Worker (Free Air); Cement Finisher; Environmental - Nuclear, Radiation, Toxic & Hazardous Waste - Levels A & B; Miner & Driller (Free Air); Tunnel Blaster; & Tunnel Mucker (Free Air); Directional & Horizontal

Boring; Air Track Drillers (All Types); Powdermen &  
 Blasters; Troxler & Concrete Tester if Laborer is Utilized

-----  
 PAIN0012-005 06/11/2005

BATH, BOURBON, BOYLE, CLARK, FAYETTE, FLEMING, FRANKLIN,  
 HARRISON, JESSAMINE, MADISON, MERCER, MONTGOMERY, NICHOLAS,  
 ROBERTSON, SCOTT & WOODFORD COUNTIES:

	Rates	Fringes
PAINTER		
Bridge/Equipment Tender and/or Containment Builder..\$	18.90	5.90
Brush & Roller.....\$	21.30	5.90
Elevated Tanks; Steeplejack Work; Bridge & Lead Abatement.....\$	22.30	5.90
Sandblasting & Waterblasting.....\$	22.05	5.90
Spray.....\$	21.80	5.90

-----  
 PAIN0012-017 05/01/2015

BRACKEN, GALLATIN, GRANT, MASON & OWEN COUNTIES:

	Rates	Fringes
PAINTER (Heavy & Highway Bridges - Guardrails - Lightpoles - Striping)		
Bridge Equipment Tender and Containment Builder.....\$	20.73	9.06
Brush & Roller.....\$	23.39	9.06
Elevated Tanks; Steeplejack Work; Bridge & Lead Abatement.....\$	24.39	9.06
Sandblasting & Water Blasting.....\$	24.14	9.06
Spray.....\$	23.89	9.06

-----  
 PAIN0118-004 06/01/2018

ANDERSON, BRECKINRIDGE, BULLITT, CARROLL, GRAYSON, HARDIN,  
 HENRY, JEFFERSON, LARUE, MARION, MEADE, NELSON, OLDHAM, SHELBY,  
 SPENCER, TRIMBLE & WASHINGTON COUNTIES:

	Rates	Fringes
PAINTER		
Brush & Roller.....\$	22.00	12.52
Spray, Sandblast, Power Tools, Waterblast & Steam Cleaning.....\$	23.00	12.52

-----  
 \* PAIN1072-003 12/01/2018

BOYD, CARTER, ELLIOTT, GREENUP, LEWIS and ROWAN COUNTIES

	Rates	Fringes
Painters:		
Bridges; Locks; Dams; Tension Towers & Energized Substations.....	\$ 33.33	18.50
Power Generating Facilities.	\$ 30.09	18.50

-----  
 PLUM0248-003 06/01/2018

BOYD, CARTER, ELLIOTT, GREENUP, LEWIS & ROWAN COUNTIES:

	Rates	Fringes
Plumber and Steamfitter.....	\$ 36.00	20.23

-----  
 PLUM0392-007 06/01/2018

BRACKEN, CARROLL (Eastern Half), GALLATIN, GRANT, MASON, OWEN &  
 ROBERTSON COUNTIES:

	Rates	Fringes
Plumbers and Pipefitters.....	\$ 32.01	19.67

-----  
 PLUM0502-003 08/01/2018

BRECKINRIDGE, BULLITT, CARROLL (Western Half), FRANKLIN  
 (Western three-fourths), GRAYSON, HARDIN, HENRY, JEFFERSON,  
 LARUE, MARION, MEADE, NELSON, OLDHAM, SHELBY, SPENCER, TRIMBLE &  
 WASHINGTON COUNTIES

	Rates	Fringes
PLUMBER.....	\$ 34.62	20.78

-----  
 SUKY2010-160 10/08/2001

	Rates	Fringes
Truck drivers:		
GROUP 1.....	\$ 16.57	7.34
GROUP 2.....	\$ 16.68	7.34
GROUP 3.....	\$ 16.86	7.34
GROUP 4.....	\$ 16.96	7.34

TRUCK DRIVER CLASSIFICATIONS

GROUP 1 - Mobile Batch Truck Tender

GROUP 2 - Greaser; Tire Changer; & Mechanic Tender

GROUP 3 - Single Axle Dump; Flatbed; Semi-trailer or Pole  
 Trailer when used to pull building materials and equipment;  
 Tandem Axle Dump; Distributor; Mixer; & Truck Mechanic

GROUP 4 - Euclid & Other Heavy Earthmoving Equipment & Lowboy; Articulator Cat; 5-Axle Vehicle; Winch & A-Frame when used in transporting materials; Ross Carrier; Forklift when used to transport building materials; & Pavement Breaker

-----  
WELDERS - Receive rate prescribed for craft performing operation to which welding is incidental.  
=====

Note: Executive Order (EO) 13706, Establishing Paid Sick Leave for Federal Contractors applies to all contracts subject to the Davis-Bacon Act for which the contract is awarded (and any solicitation was issued) on or after January 1, 2017. If this contract is covered by the EO, the contractor must provide employees with 1 hour of paid sick leave for every 30 hours they work, up to 56 hours of paid sick leave each year. Employees must be permitted to use paid sick leave for their own illness, injury or other health-related needs, including preventive care; to assist a family member (or person who is like family to the employee) who is ill, injured, or has other health-related needs, including preventive care; or for reasons resulting from, or to assist a family member (or person who is like family to the employee) who is a victim of, domestic violence, sexual assault, or stalking. Additional information on contractor requirements and worker protections under the EO is available at [www.dol.gov/whd/govcontracts](http://www.dol.gov/whd/govcontracts).

Unlisted classifications needed for work not included within the scope of the classifications listed may be added after award only as provided in the labor standards contract clauses (29CFR 5.5 (a) (1) (ii)).

-----  
The body of each wage determination lists the classification and wage rates that have been found to be prevailing for the cited type(s) of construction in the area covered by the wage determination. The classifications are listed in alphabetical order of "identifiers" that indicate whether the particular rate is a union rate (current union negotiated rate for local), a survey rate (weighted average rate) or a union average rate (weighted union average rate).

#### Union Rate Identifiers

A four letter classification abbreviation identifier enclosed in dotted lines beginning with characters other than "SU" or "UAVG" denotes that the union classification and rate were prevailing for that classification in the survey. Example: PLUM0198-005 07/01/2014. PLUM is an abbreviation identifier of the union which prevailed in the survey for this classification, which in this example would be Plumbers. 0198 indicates the local union number or district council number where applicable, i.e., Plumbers Local 0198. The next number,



005 in the example, is an internal number used in processing the wage determination. 07/01/2014 is the effective date of the most current negotiated rate, which in this example is July 1, 2014.

Union prevailing wage rates are updated to reflect all rate changes in the collective bargaining agreement (CBA) governing this classification and rate.

#### Survey Rate Identifiers

Classifications listed under the "SU" identifier indicate that no one rate prevailed for this classification in the survey and the published rate is derived by computing a weighted average rate based on all the rates reported in the survey for that classification. As this weighted average rate includes all rates reported in the survey, it may include both union and non-union rates. Example: SULA2012-007 5/13/2014. SU indicates the rates are survey rates based on a weighted average calculation of rates and are not majority rates. LA indicates the State of Louisiana. 2012 is the year of survey on which these classifications and rates are based. The next number, 007 in the example, is an internal number used in producing the wage determination. 5/13/2014 indicates the survey completion date for the classifications and rates under that identifier.

Survey wage rates are not updated and remain in effect until a new survey is conducted.

#### Union Average Rate Identifiers

Classification(s) listed under the UAVG identifier indicate that no single majority rate prevailed for those classifications; however, 100% of the data reported for the classifications was union data. EXAMPLE: UAVG-OH-0010 08/29/2014. UAVG indicates that the rate is a weighted union average rate. OH indicates the state. The next number, 0010 in the example, is an internal number used in producing the wage determination. 08/29/2014 indicates the survey completion date for the classifications and rates under that identifier.

A UAVG rate will be updated once a year, usually in January of each year, to reflect a weighted average of the current negotiated/CBA rate of the union locals from which the rate is based.

---

#### WAGE DETERMINATION APPEALS PROCESS

1.) Has there been an initial decision in the matter? This can be:

- \* an existing published wage determination
- \* a survey underlying a wage determination
- \* a Wage and Hour Division letter setting forth a position on a wage determination matter
- \* a conformance (additional classification and rate) ruling

On survey related matters, initial contact, including requests for summaries of surveys, should be with the Wage and Hour Regional Office for the area in which the survey was conducted because those Regional Offices have responsibility for the Davis-Bacon survey program. If the response from this initial contact is not satisfactory, then the process described in 2.) and 3.) should be followed.

With regard to any other matter not yet ripe for the formal process described here, initial contact should be with the Branch of Construction Wage Determinations. Write to:

Branch of Construction Wage Determinations  
Wage and Hour Division  
U.S. Department of Labor  
200 Constitution Avenue, N.W.  
Washington, DC 20210

2.) If the answer to the question in 1.) is yes, then an interested party (those affected by the action) can request review and reconsideration from the Wage and Hour Administrator (See 29 CFR Part 1.8 and 29 CFR Part 7). Write to:

Wage and Hour Administrator  
U.S. Department of Labor  
200 Constitution Avenue, N.W.  
Washington, DC 20210

The request should be accompanied by a full statement of the interested party's position and by any information (wage payment data, project description, area practice material, etc.) that the requestor considers relevant to the issue.

3.) If the decision of the Administrator is not favorable, an interested party may appeal directly to the Administrative Review Board (formerly the Wage Appeals Board). Write to:

Administrative Review Board  
U.S. Department of Labor  
200 Constitution Avenue, N.W.  
Washington, DC 20210

4.) All decisions by the Administrative Review Board are final.

=====  
END OF GENERAL DECISION

Fringe benefit amounts are applicable for all hours worked except when otherwise noted.

No laborer, workman or mechanic shall be paid at a rate less than that of a Journeyman except those classified as bona fide apprentices.

Apprentices or trainees shall be permitted to work as such subject to Administrative Regulations adopted by the Commissioner of Workplace Standards. Copies of these regulations will be furnished upon request from any interested person.

Before using apprentices on the job the contractor shall present to the Contracting Officer written evidence of registration of such employees in a program of a State apprenticeship and training agency approved and recognized by the U. S. Bureau of Apprenticeship and Training. In the absence of such a State agency, the contractor shall submit evidence of approval and registration by the U. S. Bureau of Apprenticeship and Training.

The contractor shall submit to the Contracting Officer, written evidence of the established apprenticeship-journeyman ratios and wage rates in the project area, which will be the basis for establishing such ratios and rates for the project under the applicable contract provisions.

**TO: EMPLOYERS/EMPLOYEES**

**PREVAILING WAGE SCHEDULE:**

**The wages indicated on this wage schedule are the least permitted to be paid for the occupations indicated. When an employee works in more than one classification, the employer must record the number of hours worked in each classification at the prescribed hourly base rate.**

**OVERTIME:**

**Overtime is to be paid after an employee works eight (8) hours a day or forty (40) hours a week, whichever gives the employee the greater wages. At least time and one-half the base rate is required for all overtime. A laborer, workman or mechanic and an employer may enter into a written agreement or a collective bargaining agreement to work more than eight (8) hours a calendar day but not more than ten (10) hours a calendar day for the straight time hourly rate. Wage violations or questions should be directed to the designated Engineer or the undersigned.**

Director  
Division of Construction Procurement  
Frankfort, Kentucky 40622  
502-564-3500

**NOTICE OF REQUIREMENT FOR AFFIRMATIVE ACTION  
TO ENSURE EQUAL EMPLOYMENT OPPORTUNITY  
(Executive Order 11246)**

1. The Offeror's or Bidder's attention is called to the "Equal Opportunity Clause" and the "Standard Federal Equal Employment Specifications" set forth herein.
2. The goals and timetables for minority and female participation, expressed in percentage terms for the Contractor's aggregate work force in each trade on all construction work in the covered area, are as follows:

<b>GOALS FOR MINORITY PARTICIPATION IN EACH TRADE</b>	<b>GOALS FOR FEMALE PARTICIPATION IN EACH TRADE</b>
9.6%	6.9%

These goals are applicable to all the Contractor's construction work (whether or not it is Federal or federally-assisted) performed in the covered area. If the contractor performs construction work in a geographical area located outside of the covered area, it shall apply the goals established for such geographical area where the work is actually performed. With regard to this second area, the contractor also is subject to the goals for both its federally involved and non-federally involved construction.

The Contractor's compliance with the Executive Order and the regulations in CFR Part 60-4 shall be based on its implementation of the Equal Opportunity Clause, specific affirmative action obligations required by the specifications set forth in 41 CFR 60-4, 3(a), and its efforts to meet the goals. The hours of minority and female employment and training must be substantially uniform throughout the length of the contract, and in each trade, and the contractor shall make a good faith effort to employ minorities and women evenly on each of its projects. The transfer of minority or female employees or trainees from Contractor to Contractor or from project to project for the sole purpose of meeting the Contractor's goals shall be a violation of the contract, the Executive Order and the regulations in 41 CFR Part 60-4. Compliance with the goals will be measured against the total work hours performed.

3. The Contractor shall provide written notification to the Director of the Office of Federal Contract Compliance Programs within ten (10) working days of award of any construction subcontract in excess of \$10,000.00 at any tier for construction work under the contract resulting from this solicitation. The notification shall list the name, address and telephone number of the subcontractor; employer identification number of the subcontractor; estimated dollar amount of the subcontract; estimated starting and completion dates of the subcontract; and the geographical area in which the subcontract is to be performed. The notification shall be mailed to:

**Evelyn Teague, Regional Director  
Office of Federal Contract Compliance Programs  
61 Forsyth Street, SW, Suite 7B75  
Atlanta, Georgia 30303-8609**

4. As used in this Notice, and in the contract resulting from this solicitation, the "**covered area**" is Nelson County.

**NOTICE OF REQUIREMENT FOR AFFIRMATIVE ACTION  
TO ENSURE EQUAL EMPLOYMENT OPPORTUNITY  
(Executive Order 11246)**

1. The Offeror's or Bidder's attention is called to the "Equal Opportunity Clause" and the "Standard Federal Equal Employment Specifications" set forth herein.
2. The goals and timetables for minority and female participation, expressed in percentage terms for the Contractor's aggregate work force in each trade on all construction work in the covered area, are as follows:

<b>GOALS FOR MINORITY PARTICIPATION IN EACH TRADE</b>	<b>GOALS FOR FEMALE PARTICIPATION IN EACH TRADE</b>
7.0%	6.9%

These goals are applicable to all the Contractor's construction work (whether or not it is Federal or federally-assisted) performed in the covered area. If the contractor performs construction work in a geographical area located outside of the covered area, it shall apply the goals established for such geographical area where the work is actually performed. With regard to this second area, the contractor also is subject to the goals for both its federally involved and non-federally involved construction.

The Contractor's compliance with the Executive Order and the regulations in CFR Part 60-4 shall be based on its implementation of the Equal Opportunity Clause, specific affirmative action obligations required by the specifications set forth in 41 CFR 60-4, 3(a), and its efforts to meet the goals. The hours of minority and female employment and training must be substantially uniform throughout the length of the contract, and in each trade, and the contractor shall make a good faith effort to employ minorities and women evenly on each of its projects. The transfer of minority or female employees or trainees from Contractor to Contractor or from project to project for the sole purpose of meeting the Contractor's goals shall be a violation of the contract, the Executive Order and the regulations in 41 CFR Part 60-4. Compliance with the goals will be measured against the total work hours performed.

3. The Contractor shall provide written notification to the Director of the Office of Federal Contract Compliance Programs within ten (10) working days of award of any construction subcontract in excess of \$10,000.00 at any tier for construction work under the contract resulting from this solicitation. The notification shall list the name, address and telephone number of the subcontractor; employer identification number of the subcontractor; estimated dollar amount of the subcontract; estimated starting and completion dates of the subcontract; and the geographical area in which the subcontract is to be performed. The notification shall be mailed to:

**Evelyn Teague, Regional Director  
Office of Federal Contract Compliance Programs  
61 Forsyth Street, SW, Suite 7B75  
Atlanta, Georgia 30303-8609**

4. As used in this Notice, and in the contract resulting from this solicitation, the "**covered area**" is Taylor County.

**NOTICE OF REQUIREMENT FOR AFFIRMATIVE ACTION  
TO ENSURE EQUAL EMPLOYMENT OPPORTUNITY  
(Executive Order 11246)**

1. The Offeror's or Bidder's attention is called to the "Equal Opportunity Clause" and the "Standard Federal Equal Employment Specifications" set forth herein.
2. The goals and timetables for minority and female participation, expressed in percentage terms for the Contractor's aggregate work force in each trade on all construction work in the covered area, are as follows:

<b>GOALS FOR MINORITY PARTICIPATION IN EACH TRADE</b>	<b>GOALS FOR FEMALE PARTICIPATION IN EACH TRADE</b>
9.6%	6.9%

These goals are applicable to all the Contractor's construction work (whether or not it is Federal or federally-assisted) performed in the covered area. If the contractor performs construction work in a geographical area located outside of the covered area, it shall apply the goals established for such geographical area where the work is actually performed. With regard to this second area, the contractor also is subject to the goals for both its federally involved and non-federally involved construction.

The Contractor's compliance with the Executive Order and the regulations in CFR Part 60-4 shall be based on its implementation of the Equal Opportunity Clause, specific affirmative action obligations required by the specifications set forth in 41 CFR 60-4, 3(a), and its efforts to meet the goals. The hours of minority and female employment and training must be substantially uniform throughout the length of the contract, and in each trade, and the contractor shall make a good faith effort to employ minorities and women evenly on each of its projects. The transfer of minority or female employees or trainees from Contractor to Contractor or from project to project for the sole purpose of meeting the Contractor's goals shall be a violation of the contract, the Executive Order and the regulations in 41 CFR Part 60-4. Compliance with the goals will be measured against the total work hours performed.

3. The Contractor shall provide written notification to the Director of the Office of Federal Contract Compliance Programs within ten (10) working days of award of any construction subcontract in excess of \$10,000.00 at any tier for construction work under the contract resulting from this solicitation. The notification shall list the name, address and telephone number of the subcontractor; employer identification number of the subcontractor; estimated dollar amount of the subcontract; estimated starting and completion dates of the subcontract; and the geographical area in which the subcontract is to be performed. The notification shall be mailed to:

**Evelyn Teague, Regional Director  
Office of Federal Contract Compliance Programs  
61 Forsyth Street, SW, Suite 7B75  
Atlanta, Georgia 30303-8609**

4. As used in this Notice, and in the contract resulting from this solicitation, the "**covered area**" is Washington County.

**PART IV**  
**INSURANCE**

## INSURANCE

The Contractor shall procure and maintain the following insurance in addition to the insurance required by law:

- 1) Commercial General Liability-Occurrence form – not less than \$2,000,000 General aggregate, \$2,000,000 Products & Completed Aggregate, \$1,000,000 Personal & Advertising, \$1,000,000 each occurrence.
- 2) Automobile Liability- \$1,000,000 per accident
- 3) Employers Liability:
  - a) \$100,000 Each Accident Bodily Injury
  - b) \$500,000 Policy limit Bodily Injury by Disease
  - c) \$100,000 Each Employee Bodily Injury by Disease
- 4) The insurance required above must be evidenced by a Certificate of Insurance and this Certificate of Insurance must contain one of the following statements:
  - a) "policy contains no deductible clauses."
  - b) "policy contains \_\_\_\_\_ (amount) deductible property damage clause but company will pay claim and collect the deductible from the insured."
- 5) KENTUCKY WORKMEN'S COMPENSATION INSURANCE. The contractor shall furnish evidence of coverage of all his employees or give evidence of self-insurance by submitting a copy of a certificate issued by the Workmen's Compensation Board.

The cost of insurance is incidental to all contract items. All subcontractors must meet the same minimum insurance requirements.



**PART V**  
**BID ITEMS**

### PROPOSAL BID ITEMS

194205

Page 1 of 2

Report Date 1/28/19

#### Section: 0001 - ROADWAY

LINE	BID CODE	ALT	DESCRIPTION	QUANTITY	UNIT	UNIT PRIC	FP	AMOUNT
0010	01987		DELINEATOR FOR GUARDRAIL BI DIRECTIONAL WHITE	1,690.00	EACH		\$	
0020	02562		TEMPORARY SIGNS	760.00	SQFT		\$	
0030	02650		MAINTAIN & CONTROL TRAFFIC (NELSON KY 245 @ KY 1430)	1.00	LS		\$	
0040	02650		MAINTAIN & CONTROL TRAFFIC (TAYLOR US 68 @ KY 289)	1.00	LS		\$	
0050	02650		MAINTAIN & CONTROL TRAFFIC (WASHINGTON KY 555 @ KY 528)	1.00	LS		\$	
0060	02650		MAINTAIN & CONTROL TRAFFIC (WASHINGTON KY 555 @ US 150)	1.00	LS		\$	
0070	02775		ARROW PANEL	4.00	EACH		\$	
0080	04960		REMOVE AND REPLACE SIDEWALK	2.00	SQYD		\$	
0090	05990		SODDING	80.00	SQYD		\$	
0100	06514		PAVE STRIPING-PERM PAINT-4 IN	1,200.00	LF		\$	
0110	06546		PAVE STRIPING-THERMO-12 IN W	650.00	LF		\$	
0120	06566		PAVE MARKING-THERMO X-WALK-12 IN	460.00	LF		\$	
0130	06568		PAVE MARKING-THERMO STOP BAR-24IN	345.00	LF		\$	
0140	06574		PAVE MARKING-THERMO CURV ARROW	32.00	EACH		\$	
0150	06598		PAVEMENT MARKING REMOVAL	100.00	SQFT		\$	
0160	22520EN		PAVE MARKING-THERMO YIELD BAR-36 IN	60.00	LF		\$	
0170	23158ES505		DETECTABLE WARNINGS	10.00	SQFT		\$	
0180	24683ED		PAVE MARKING-THERMO DOTTED LANE EXTEN	160.00	LF		\$	

#### Section: 0002 - SIGNALIZATION

LINE	BID CODE	ALT	DESCRIPTION	QUANTITY	UNIT	UNIT PRIC	FP	AMOUNT
0190	04792		CONDUIT-1 IN	25.00	LF		\$	
0200	04795		CONDUIT-2 IN	20.00	LF		\$	
0210	04797		CONDUIT-3 IN	10.00	LF		\$	
0220	04811		ELECTRICAL JUNCTION BOX TYPE B	10.00	EACH		\$	
0230	04820		TRENCHING AND BACKFILLING	2,080.00	LF		\$	
0240	04830		LOOP WIRE	350.00	LF		\$	
0250	04844		CABLE-NO. 14/5C	8,997.00	LF		\$	
0260	04850		CABLE-NO. 14/1 PAIR	4,575.00	LF		\$	
0270	04884		ANCHOR	2.00	EACH		\$	
0280	04885		MESSENGER-10800 LB	505.00	LF		\$	
0290	04886		MESSENGER-15400 LB	175.00	LF		\$	
0300	04895		LOOP SAW SLOT AND FILL	115.00	LF		\$	
0310	04931		INSTALL CONTROLLER TYPE 170	1.00	EACH		\$	
0320	04932		INSTALL STEEL STRAIN POLE	5.00	EACH		\$	
0330	06472		INSTALL SPAN MOUNTED SIGN	1.00	EACH		\$	
0340	20093NS835		INSTALL PEDESTRIAN HEAD-LED	2.00	EACH		\$	
0350	20094ES835		TEMP RELOCATION OF SIGNAL HEAD	20.00	EACH		\$	
0360	20188NS835		INSTALL LED SIGNAL-3 SECTION	34.00	EACH		\$	
0370	20266ES835		INSTALL LED SIGNAL- 4 SECTION	22.00	EACH		\$	

**PROPOSAL BID ITEMS**

194205

Page 2 of 2

Report Date 1/28/19

LINE	BID CODE	ALT	DESCRIPTION	QUANTITY	UNIT	UNIT PRIC	FP	AMOUNT
0380	20390NS835		INSTALL COORDINATING UNIT	2.00	EACH		\$	
0390	20408ES835		INSTALL LED BEACON-12 IN	4.00	EACH		\$	
0400	21543EN		BORE AND JACK CONDUIT	50.00	LF		\$	
0410	21743NN		INSTALL PEDESTRIAN DETECTOR	2.00	EACH		\$	
0420	23157EN		TRAFFIC SIGNAL POLE BASE	23.00	CUYD		\$	
0430	24525EC		ADVANCE WARNING FLASHER	2.00	EACH		\$	
0440	24900EC		PVC CONDUIT-1 1/4 IN-SCHEDULE 80	165.00	LF		\$	
0450	24901EC		PVC CONDUIT-2 IN-SCHEDULE 80	2,080.00	LF		\$	
0460	24908EC		INSTALL SIGNAL CONTROLLER-TY ATC	2.00	EACH		\$	
0470	24955ED		REMOVE SIGNAL EQUIPMENT (NELSON KY 245 @ KY 1430)	1.00	EACH		\$	
0480	24955ED		REMOVE SIGNAL EQUIPMENT (TAYLOR US 68 @ KY 289)	1.00	EACH		\$	
0490	24955ED		REMOVE SIGNAL EQUIPMENT (WASHINGTON KY 555 @ KY 528)	1.00	EACH		\$	
0500	24955ED		REMOVE SIGNAL EQUIPMENT (WASHINGTON KY 555 @ US 150)	1.00	EACH		\$	

**Section: 0003 - DEMOBILIZATION**

LINE	BID CODE	ALT	DESCRIPTION	QUANTITY	UNIT	UNIT PRIC	FP	AMOUNT
0510	02569		DEMOBILIZATION	1.00	LS		\$	