

FILE NAME: H:\Resources\Bases\_Sheets\Diaphragms\English\Current\pci\_4\_diaphr agms.dgn

USER: earlw.downey  
DATE PLOTTED: 25-APR-2018

E-SHEET NAME:

MicroStation v8.11.7.180

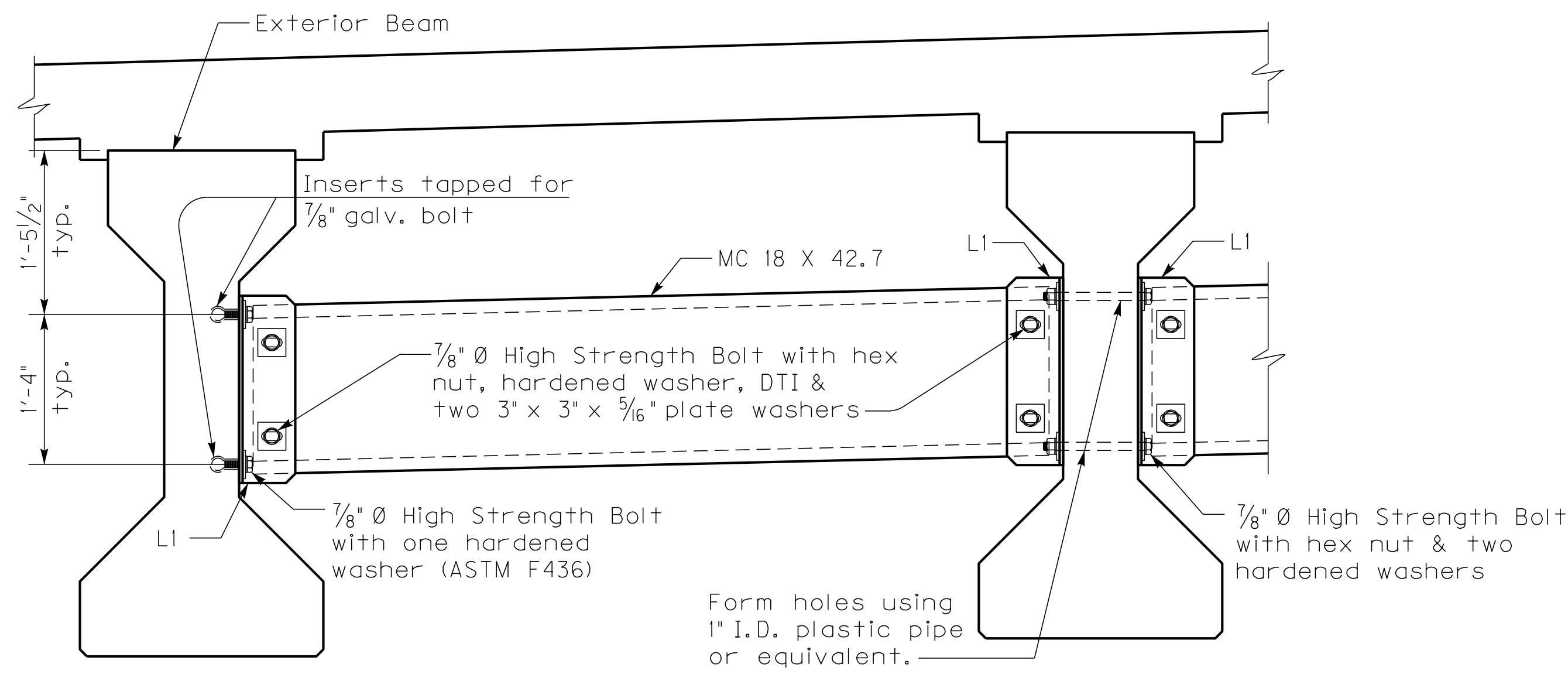

**INTERMEDIATE DIAPHRAGM**  
~Typical for 0° Skew PCI, Type 4 Beams~

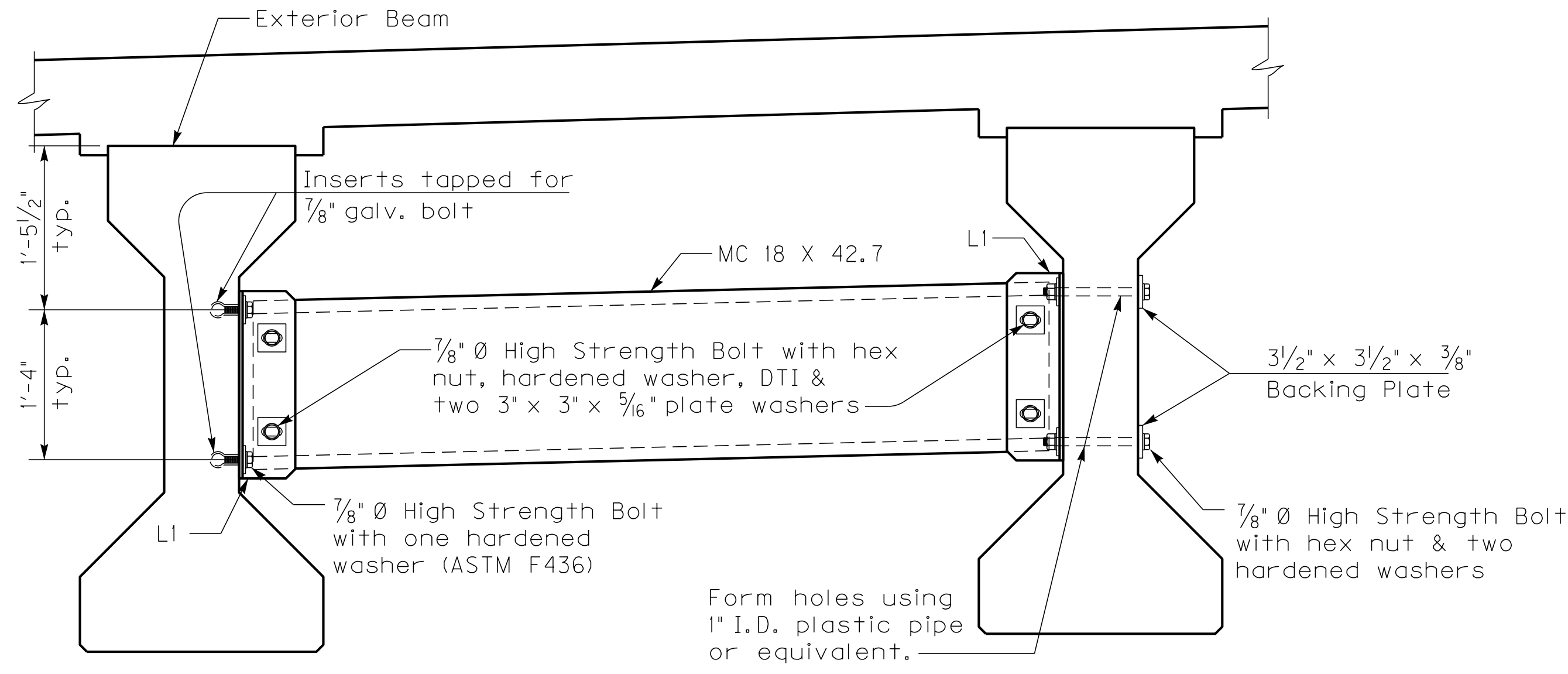

**INTERMEDIATE DIAPHRAGM**  
~Typical for Skewed PCI, Type 4 Beams~

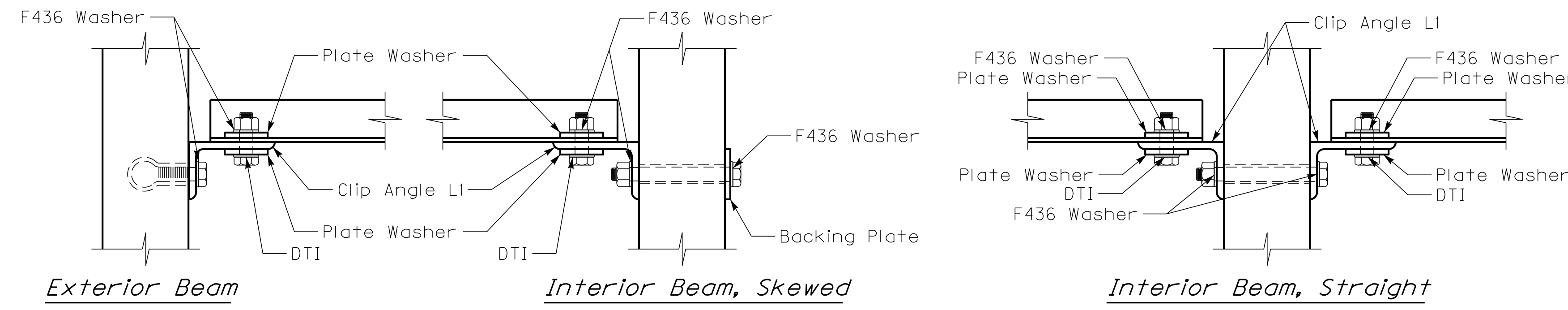

**CONNECTION DETAILS**

**Diaphragm Notes**

**CONNECTIONS:** Ensure all bolted connections are ASTM A325, 7/8 inch diameter high strength bolts, nuts, and washers, mechanically zinc coated in accordance with AASHTO M298, for Class 50. Install all high strength bolted field connections using 'direct tension indicators' (DTI's) in accordance with the Standard Specifications and ASTM F959. Ensure all DTI's are mechanically zinc coated. Show installation details of the DTI's on the shop plans. Place DTI's under the bolt head. ASTM A449 bolts may be used in lieu of A325 for the bolts carried through the girder webs only.

**STRUCTURAL STEEL:** Ensure plates, angles, and channels conform to ASTM A36 or A572 and galvanized after fabrication.

**SHOP DRAWINGS:** Show the location of all inserts and holes on the precast beam shop drawings. Submit shop drawings for the steel diaphragms to the Division of Structural Design for approval.

**DIAPHRAGMS:** Erect the diaphragms the same day that the precast beams are placed on the substructure. Include the cost of all materials and labor required to fabricate and erect the diaphragms in the bid for Precast Beams.

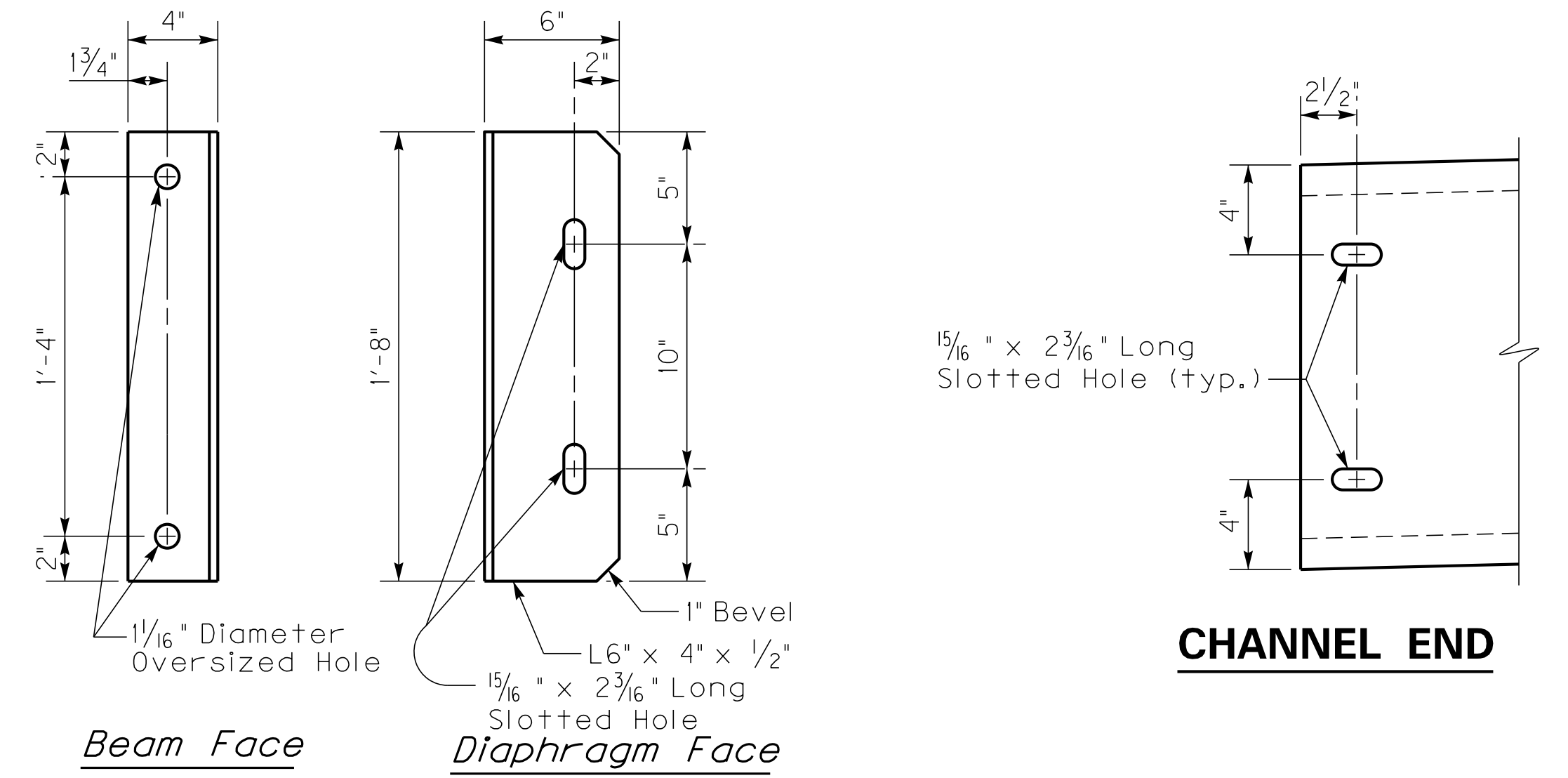

**CLIP ANGLE - L1**

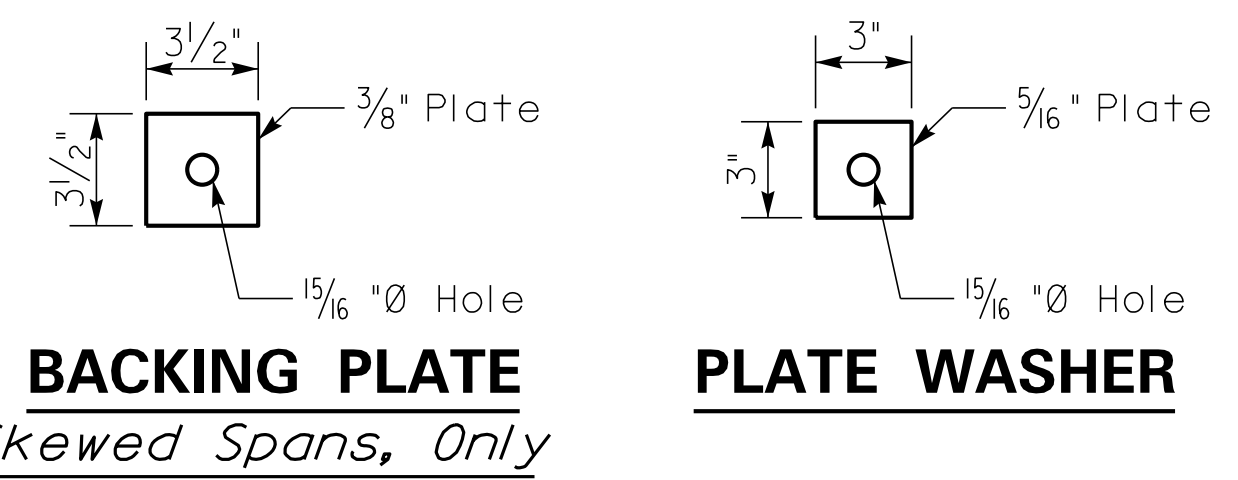

**BACKING PLATE**  
Skewed Spans, Only

**PLATE WASHER**

REVISION		DATE
DATE:	CHECKED BY	
DESIGNED BY:		
DETAILED BY:		
<b>Commonwealth of Kentucky</b> <b>DEPARTMENT OF HIGHWAYS</b>		
COUNTY		
ROUTE	CROSSING	
ITEM NUMBER	PREPARED BY	SHEET NO.
	<b>Division of Structural Design</b>	DRAWING NO.