

50-70 FT OVERHEAD SIGN SUPPORT TRUSS GENERAL NOTES

Specifications:

All references to the standard specifications are to the 2019 Edition of the Kentucky Transportation Cabinet Standard Specifications for Road and Bridge Construction. All references to the AASHTO Specifications are to the AASHTO LRFD Specifications for Structural Supports for Highway Signs, Luminaires, and Traffic Signals with Interims through 2022.

Design:

Designed in accordance with AASHTO LRFD Specifications for Structural Supports for Highway Signs, Luminaires, and Traffic Signals with Interims through 2022 using the following parameters:

- 1700 year MRI, with 120 MPH Design Wind Speed
- Infinite Fatigue Life
- 10 year MRI 76 MPH Service Wind Speed
- Fatigue Design Loads: Natural Wind Gust, Truck-Induced Wind Gust

Superelevation of Roadway:

The contractor shall allow for differences in elevations across the full shoulder width as shown in the Roadway Plans in maintaining the required 18 foot minimum vertical clearance to the bottom, of the lowest part of the sign or support. Sign shall be centered over the lane or lanes to which it applies, or as specified in the Signing Plans.

Material Design Specifications:

For Class "A" Concrete $f'c = 3,500$ psi
 For Steel Reinforcement $fy = 60,000$ psi
 For Structural Aluminum $fy = 35,000$ psi

Material Specifications:

AASHTO Specifications or ASTM, Current edition, as designated below shall govern the materials furnished:

Structural Aluminum:

6061-T6	Aluminum Extruded Tube	B221-21
6061-T6	Aluminum Extruded Tube; seamless	B0241-22
6061-T6	Aluminum Structural Shapes	B0308-20
6061-T6	Aluminum Sheet and Plate	B0209-21A
356.0-T6	Aluminum Sand Mold Casting	B0026-18E01
356.0-T6	Aluminum Permanent Mold Casting	B0108-19
Grade L7	Stainless steel hardware	A0320-22
Grade 12	Cadmium coatings for anchor bolts	B0766-23

Concrete:

Class "A" Concrete shall be used throughout, and shall be paid for at the unit bid price for Class "A" Concrete for Signs.

Beveled Edges:

All exposed concrete edges are to be beveled $\frac{3}{4}$ " unless otherwise shown.

Reinforcement:

Dimensions shown from the face of concrete to bars are to center of bar unless otherwise shown. Spacing of bars is from center to center of bars. Clear distance to face of concrete is 2 inches unless otherwise noted. Reinforcing bars in the plans shall be epoxy coated in accordance with section 811.10 of the Standard Specifications.

Any reinforcing bars designated by the suffix (s) in a Bill of Reinforcement shall be considered a stirrup bar for purposes of bend diameters.

Payment for reinforcement shall be paid for at the unit bid price for Steel Reinforcement for Signs.

Shop Drawings:

The contractor shall submit detailed shop drawings to the Division of Construction for review prior to fabrication in accordance with the specifications. The roadway cross section developed by the contractor is to accompany the shop drawings. The shop drawings and roadway cross section will also be forwarded to the engineer to review.

Bolted Connections:

All bolted connections shall include lock washers. After bolted connections are complete, threads shall be scored to prevent nut loosening. Care shall be taken not to damage the nut and threads engaged by the nut. Damaged nuts shall be replaced at the contractors expense.

Fabrication:

The sign support shall be fabricated in accordance with the AASHTO Specifications. Perform all welding according to requirements specified in ANSI/AASHTO/AWS D1.2 Structural Welding Code Current edition with interims.

Mill Test Reports:

Submit Mill Test Reports in accordance with section 607.03.13 of the Standard Specifications

Footings:

All footings shall be poured against undisturbed earth. The maximum allowable service bearing pressure is 3 kips per square foot.

Design Limits:

This standard drawing is applicable to all overhead sign supports that meet the following criteria:

Maximum Total Sign Area:	400 SF
Minimum Vertical Clearance of Sign Above Roadway:	18 FT
Maximum Height of Sign Above Roadway:	44 FT
Maximum Sign Panel Height:	24 FT
Maximum Exit Panel Height:	4.5 FT
Span Range:	50 FT - 70 FT
Min. Sign Edge Distance to Column CL:	12 FT
Max./Min. Column Height (HL/HR):	27 FT / 18 FT
Max. Pedestal Height (FL/FR):	14 FT
Min. Pedestal Offset behind Guardrail:	6 FT
Min. Pedestal Projection above soil:	2.5 FT
Min. Fill above Base of Footing:	3 FT

Design Chart:

A registered professional engineer licensed to practice in the Commonwealth of Kentucky shall fill out the Design Chart based on the design cross section at the location where the truss is to be erected, the actual signs to be used, and the instructions herein. The Engineer's name shall appear in the "Checked By:" Box of the title block of this sheet. The Engineer is responsible for verifying the information based on the contractor's submitted cross sections and reviewing the fabricators shop drawings in detail.

Roadway Cross Section:

The contractor shall take field measurements at each sign location and develop a cross section showing the following:

- Pedestal and median heights
- Pedestal offset distance behind guardrail
- Column Heights
- Minimum Vertical Clearance to each sign

Any work associated with developing and furnishing the Roadway Cross Section shall be incidental to OSS Sign Truss.

Payment:

All engineering, materials, labor, equipment, and any other incidentals necessary to furnish and install the sign truss as detailed in these standards and the shop drawings shall be paid for at the unit bid price for OSS Sign Truss.

Fabricator Certification:

The fabricator shall be AISC Certified for SBR (Certified Bridge Fabricator - Simple).

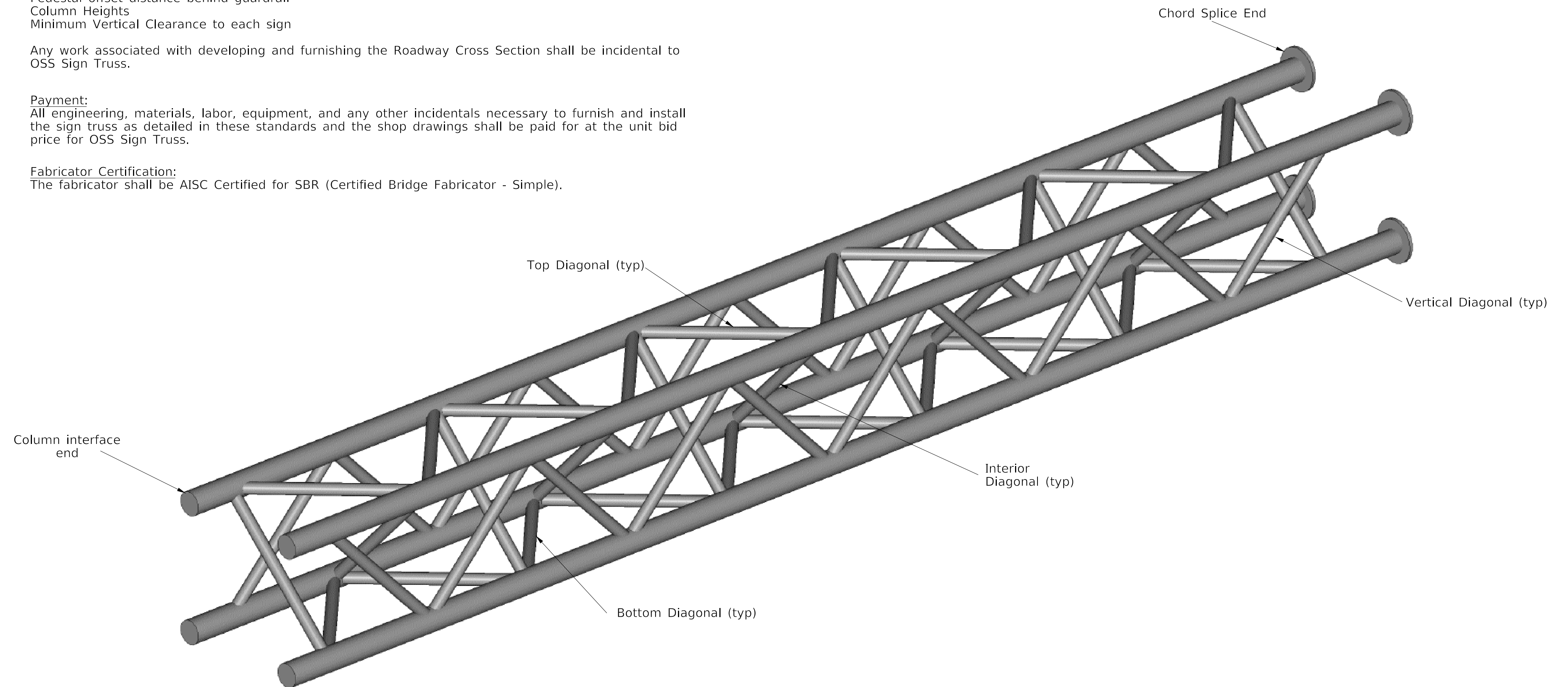

ISOMETRIC VIEW OF TYPICAL TRUSS MODULE
(FOR INFORMATION ONLY)



COMMONWEALTH OF KENTUCKY
DEPARTMENT OF HIGHWAYS



REVISION	DATE

PREPARED BY	DATE:

CHECKED BY	DESIGNED BY:

GENERAL NOTES	
CROSSING	

ROUTE	ITEM NO.
	SHEET NO.

COUNTY OF

Support No.	STATION	SPAN		SUPPORT HEIGHT		FOOTING HEIGHT						
		L		HL	HR	FL	FR					
Total Area**	SIGN A				SIGN B				SIGN C			
	I.D.	Horiz.	Vert.	Area*	I.D.	Horiz.	Vert.	Area*	I.D.	Horiz.	Vert.	Area*
	SIGN D				SIGN E				SIGN F			
	I.D.	Horiz.	Vert.	Area*	I.D.	Horiz.	Vert.	Area*	I.D.	Horiz.	Vert.	Area*
	SIGN D				SIGN E				SIGN F			
	I.D.	Horiz.	Vert.	Area*	I.D.	Horiz.	Vert.	Area*	I.D.	Horiz.	Vert.	Area*

* Area includes Exit Number Signs that are not shown.
 ** Total Area includes the sum of all of the signs on the structure and shall not exceed 400 square feet.
 ① Maximum space between sign brackets = 4'-0"
 Maximum sign overhang past chord at sign brackets = 2'-0"

L	Y
50	3/16"
55	1/4"
60	1/4"
65	5/16"
70	3/8"

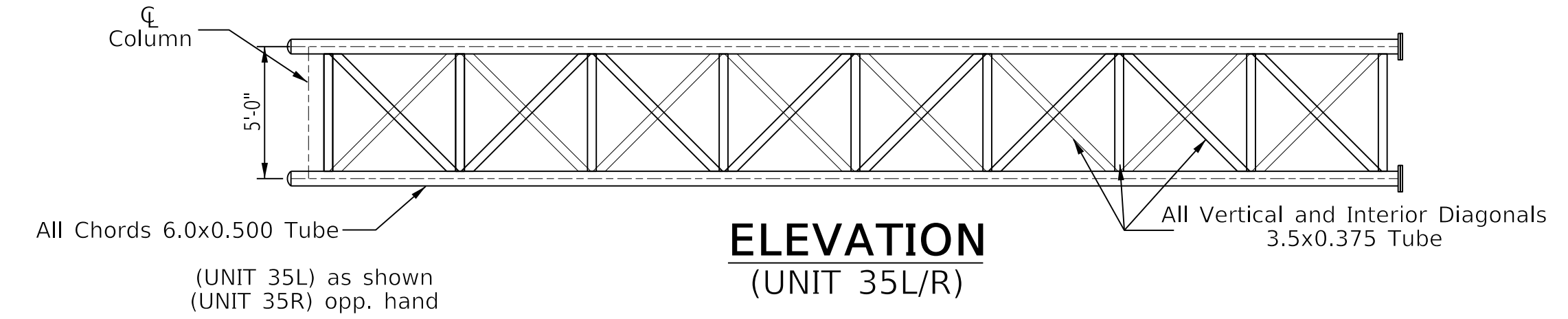
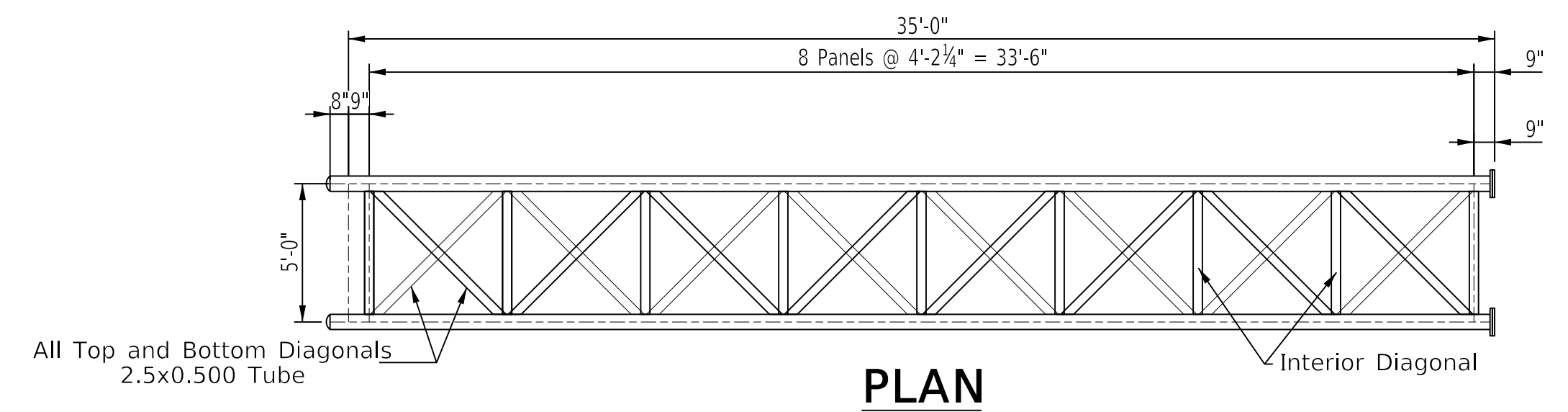
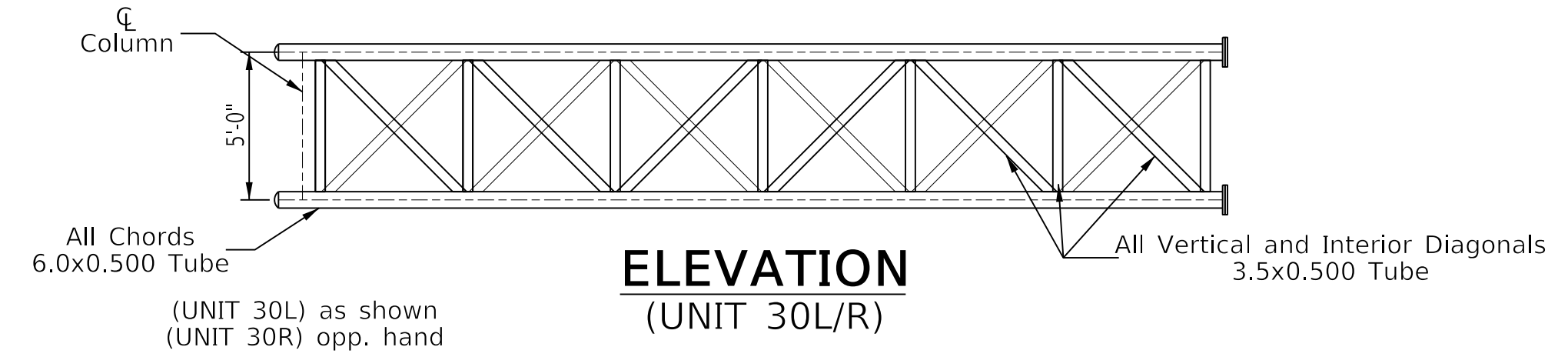
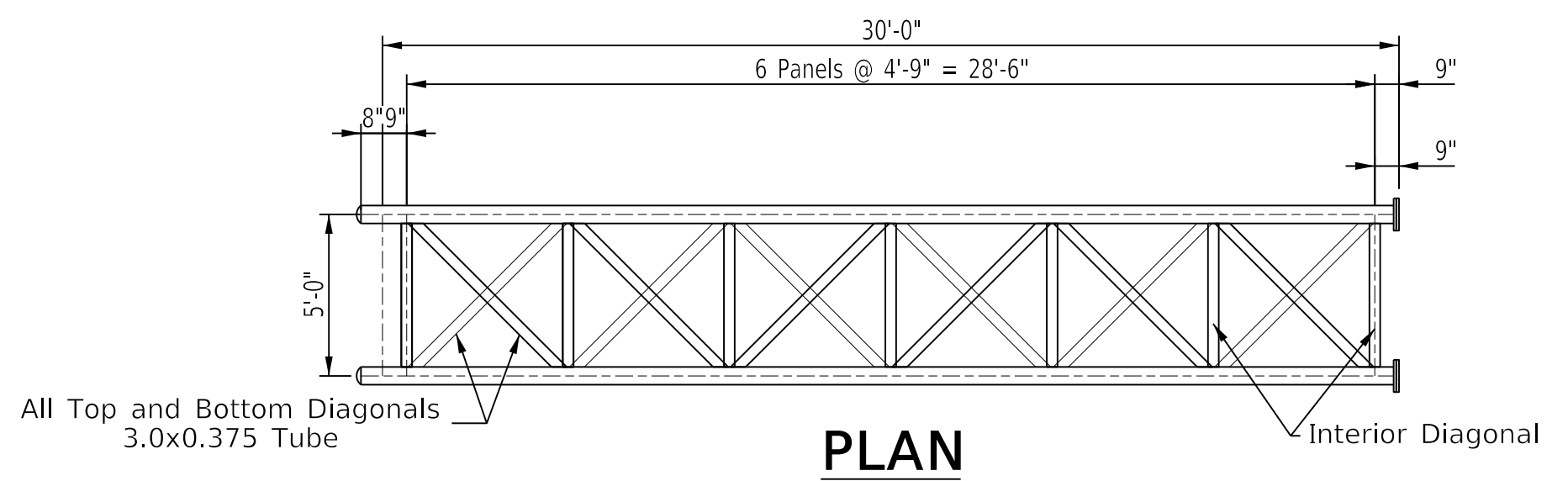
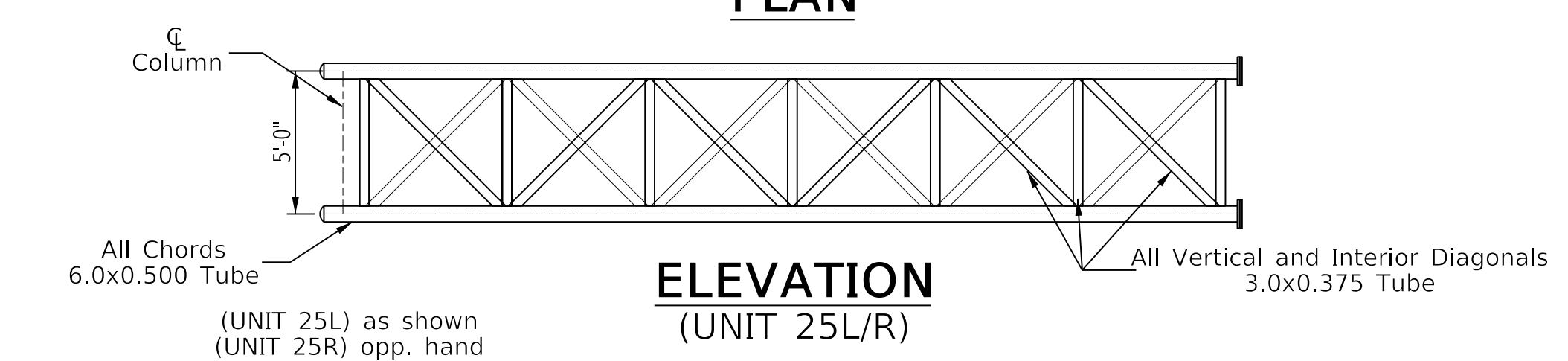
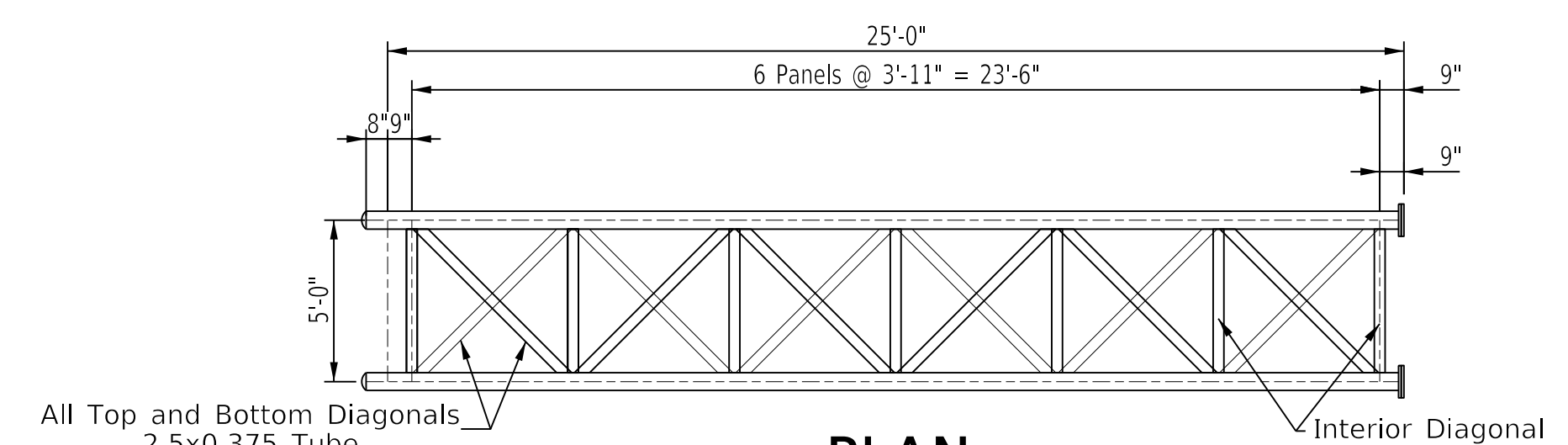
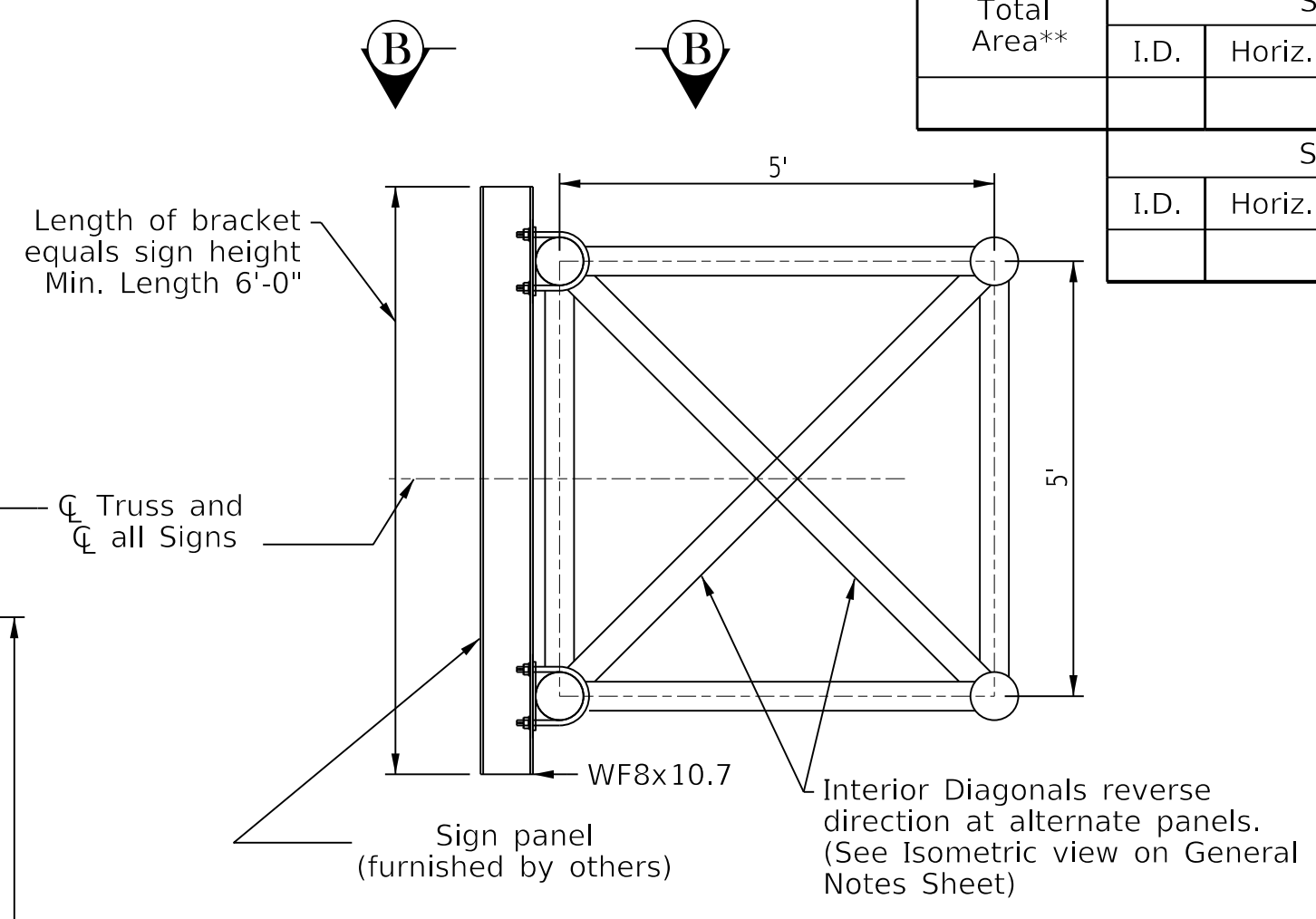
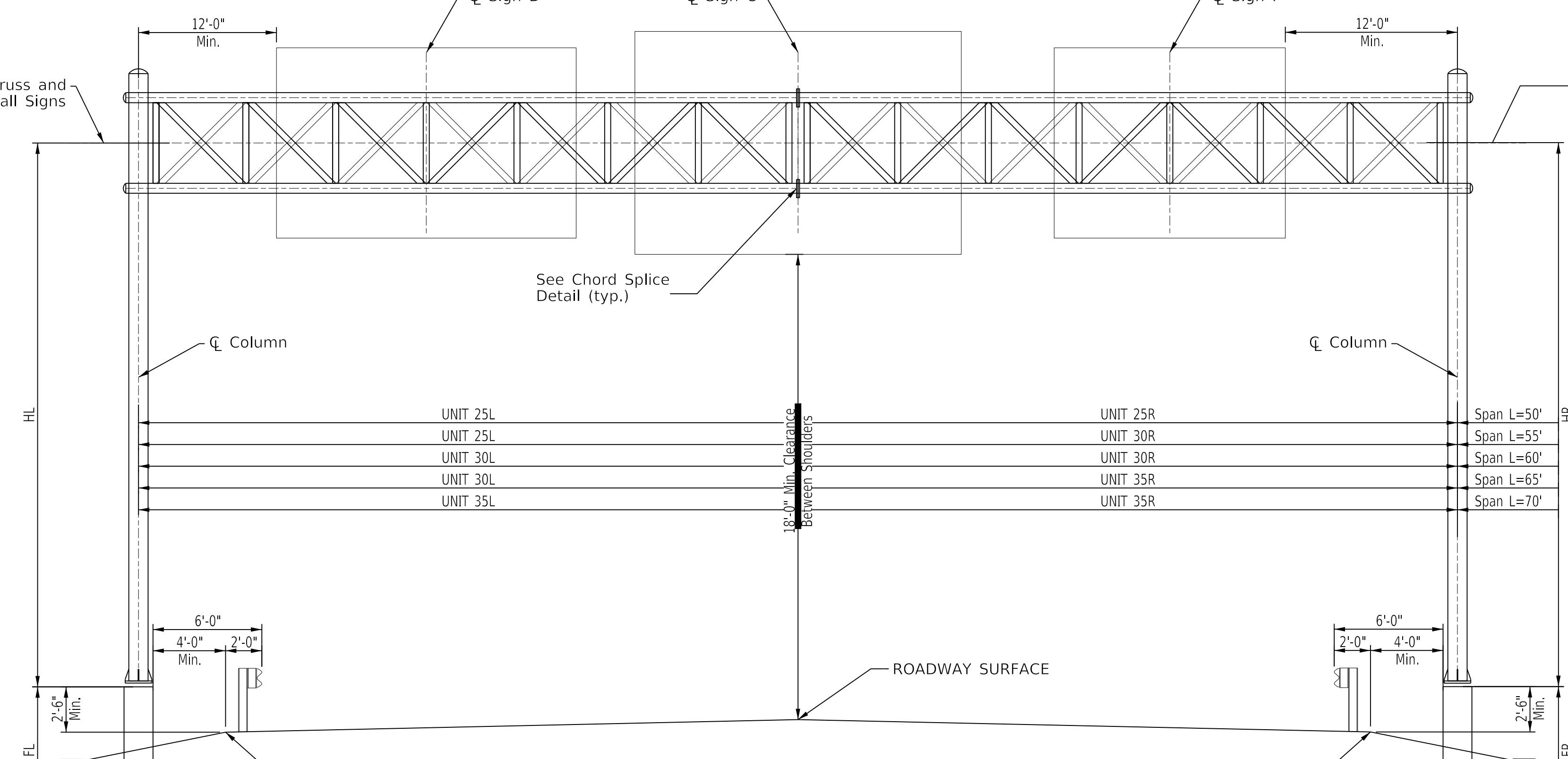
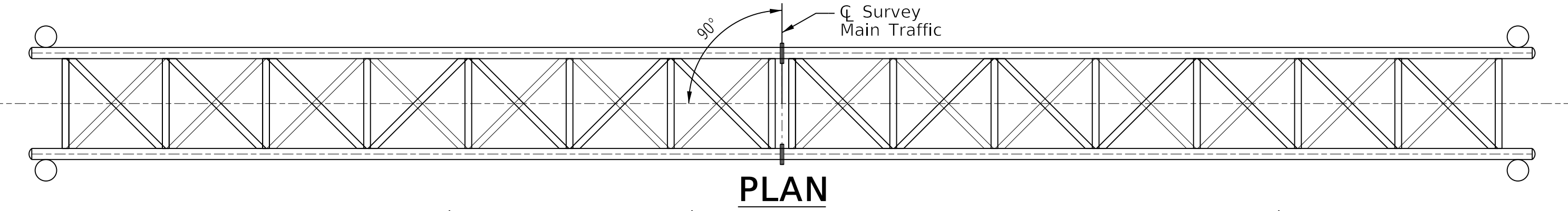
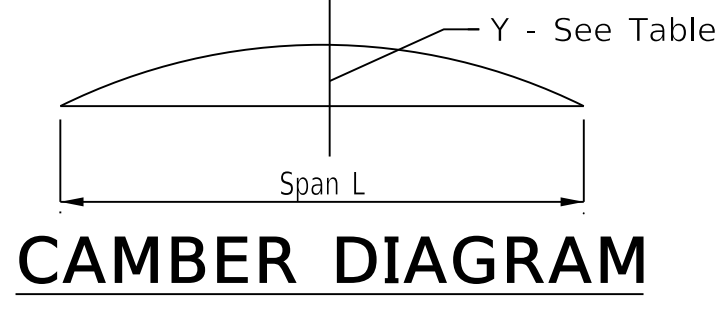

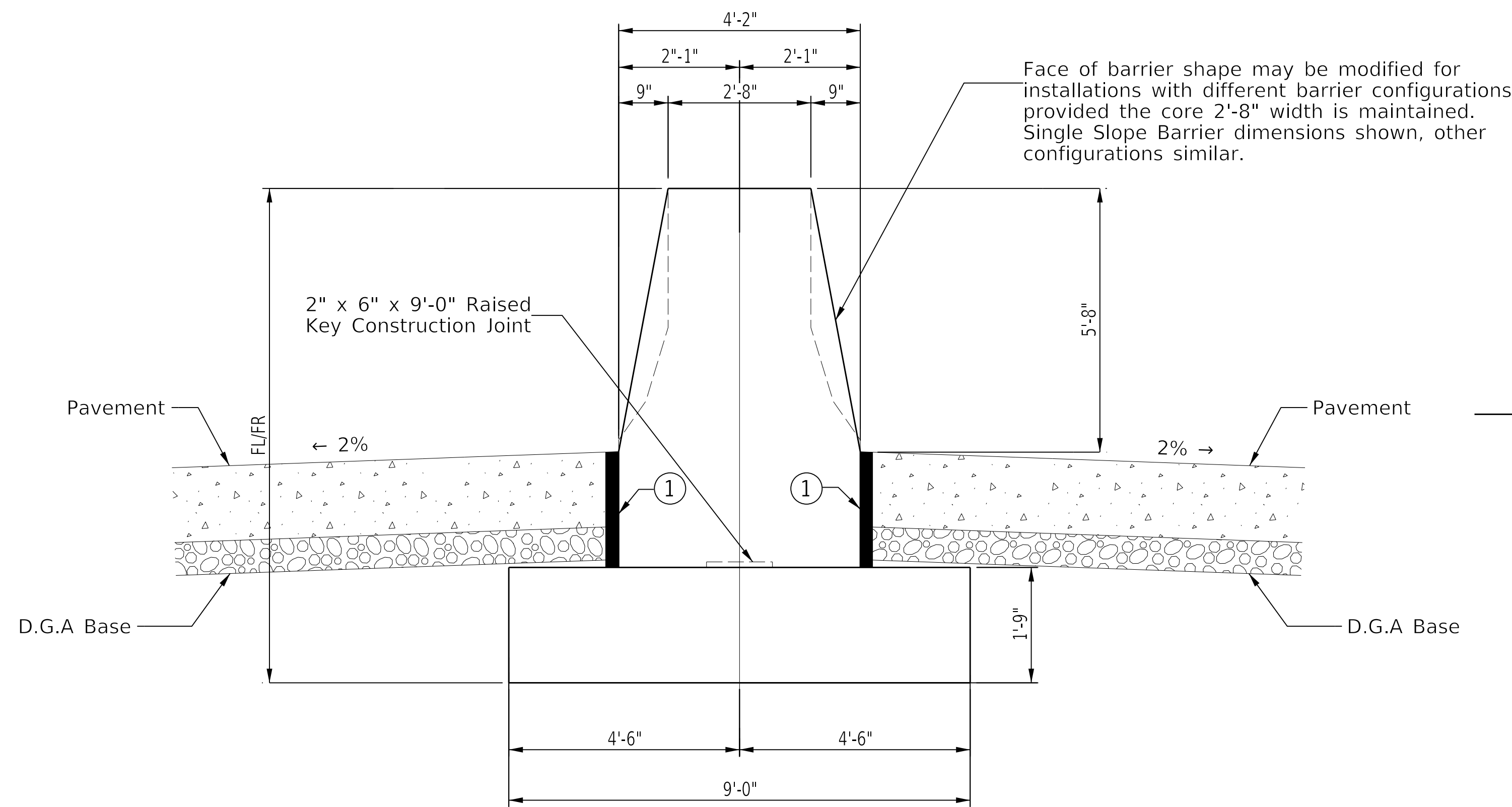

END VIEW MEDIAN
(At Sign Truss)

Note:
① 1/2" PRE-MOLDED EXPANSION MATERIAL

NOTE:
FOR DETAILS SEE TRUSS LAYOUT
AND TRUSS DETAILS SHEET

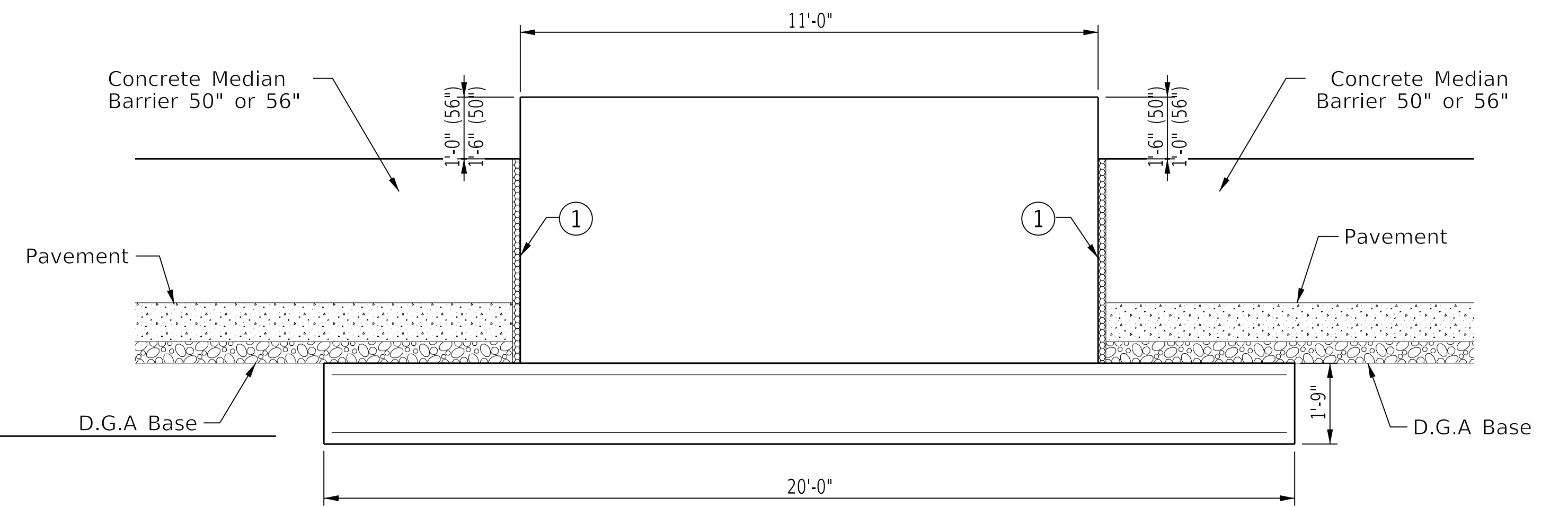

SIDE ELEVATION MEDIAN

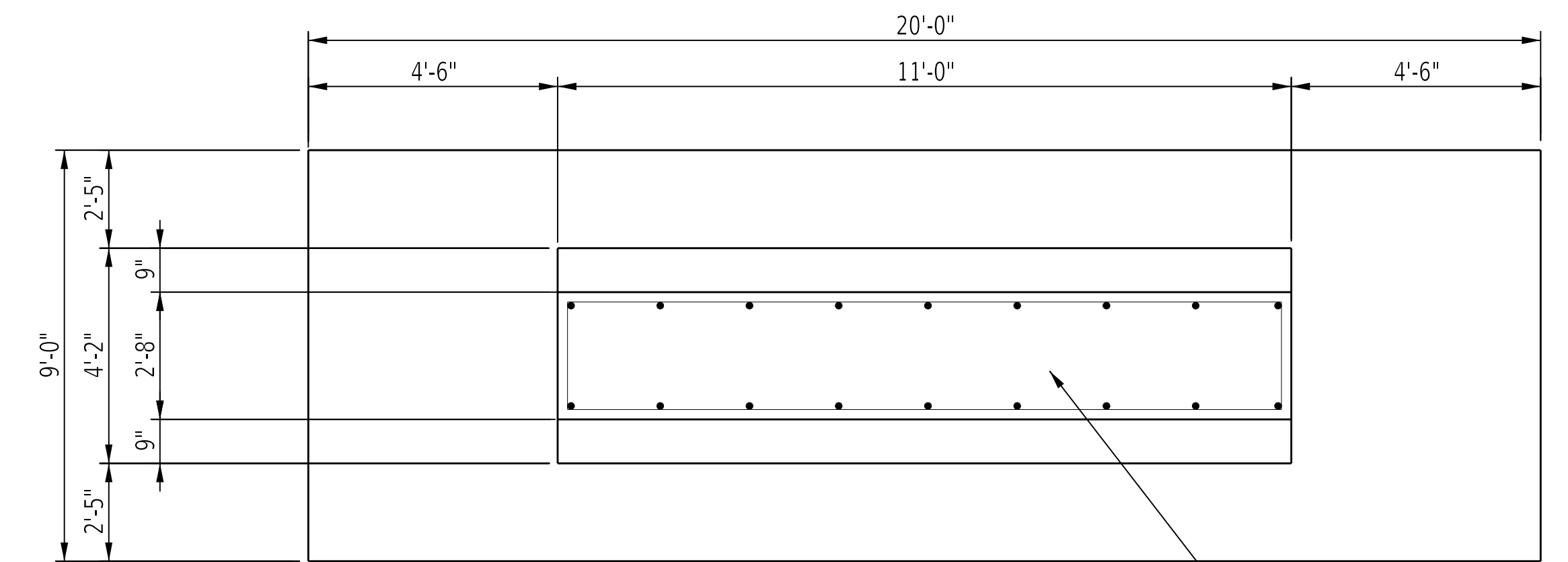

PLAN VIEW MEDIAN

SEE TRUSS DETAILS SHEET
FOR REINFORCEMENT

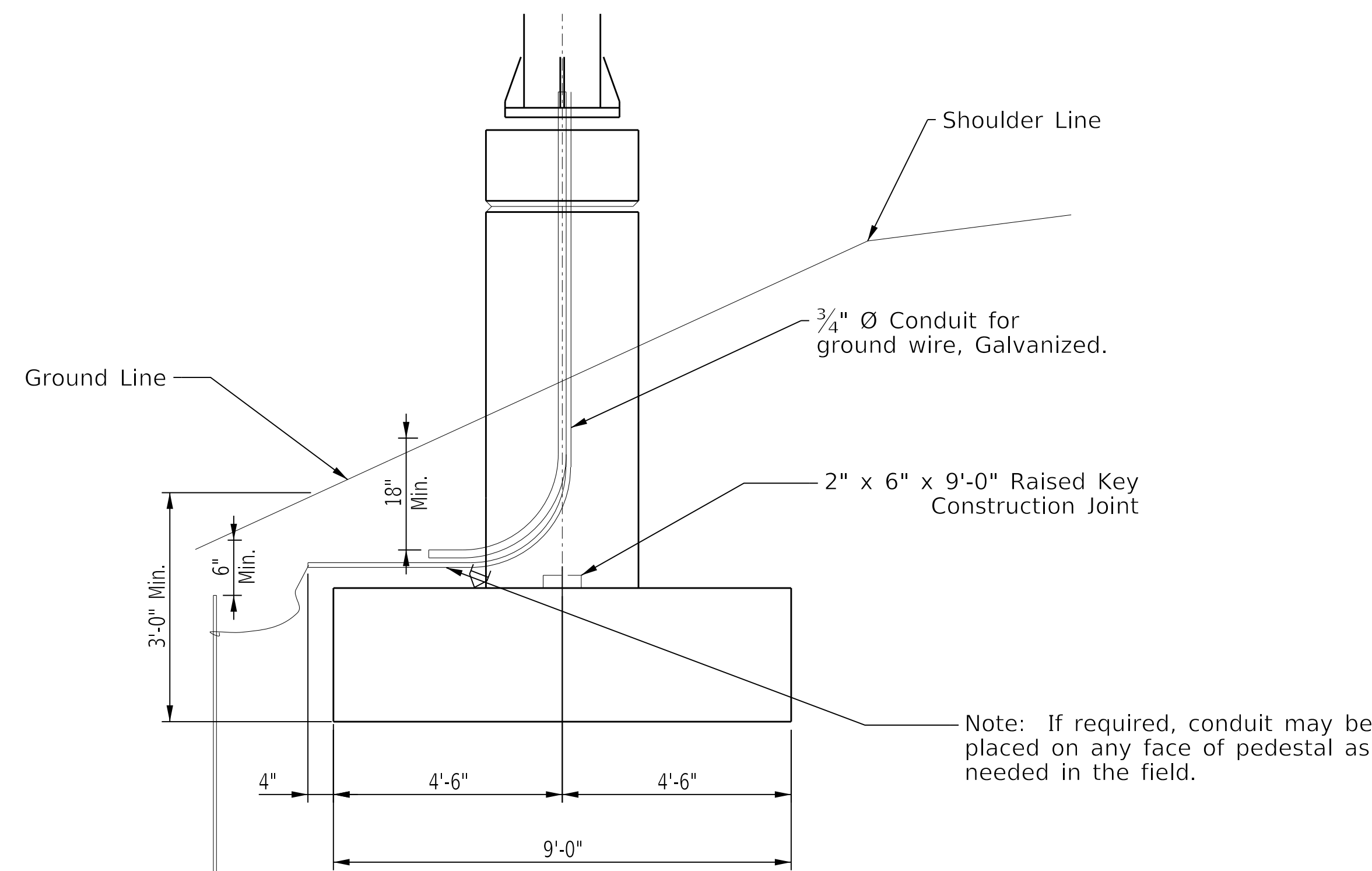

END VIEW PEDESTAL

See Truss Details Sheet for Plan View

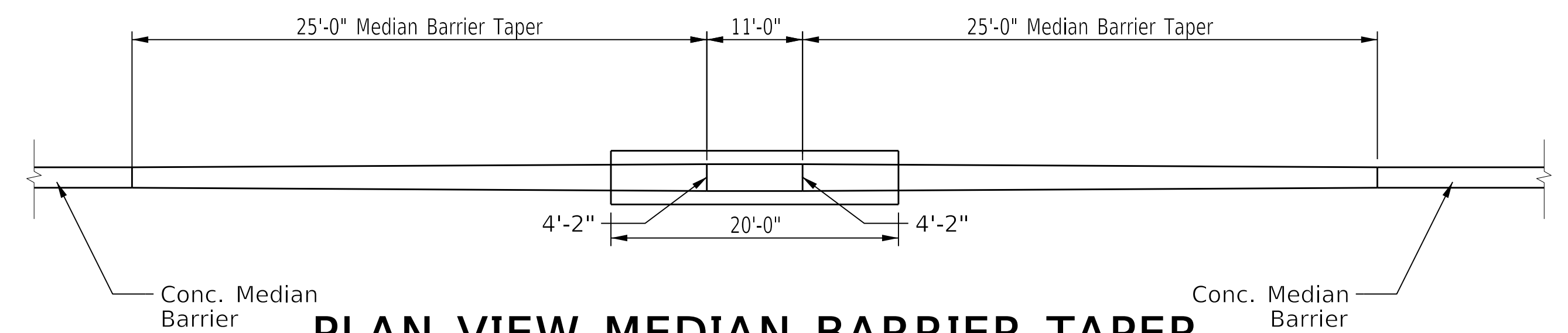

PLAN VIEW MEDIAN BARRIER TAPER

* Approx. estimate is for information only. Tabulated FL/FR shall be verified by the Engineer in the field.

* ESTIMATE OF QUANTITIES FOR MEDIAN FOOTING		
	Conc. Class "A"	Steel Reinforcement
FL/FR=8'-2"	20.8 cu.yds.	1796 lbs
1' of additional Pedestal height	1.7 cu.yds.	100 lbs

Quantities for 8'-2" FL/FR assumes 9" pavement/DGA base thickness



COMMONWEALTH OF KENTUCKY
DEPARTMENT OF HIGHWAYS



REVISION	DATE

PREPARED BY

DATE:

DESIGNED BY:

DETAILED BY:

CHECKED BY

FOUNDATION LAYOUT

CROSSING

ROUTE

ITEM NO.

COUNTY OF

SHEET NO.