



**Hickman-Fulton County  
Riverport Authority**

**2024**

**HFCRA Spreader Bar and Coil Hooks**

**Projected Total Cost \$ 24,500**

**June 3, 2024**

**Prepared By:**

**Greg Curlin**

**Executive Director**



KENTUCKY RIVERPORT IMPROVEMENT (KRI) APPLICATION

INSTRUCTIONS: A guidance document is provided to assist in completing the application packet and may be accessed at https://transportation.ky.gov/MultimodalFreight/Pages/Ky-Riverport-Grant-Program.aspx See the guidance document for required attachments and acceptable methods of submittal.

SECTION 1: APPLICANT INFORMATION

Table with 4 columns: RIVERPORT NAME, TOTAL PROJECT COST, KRI GRANT REQUEST, APPLICATION YEAR. Includes fields for STREET ADDRESS, CITY, STATE, ZIP, CONTACT NAME & TITLE, PHONE, and EMAIL.

SECTION 2: PROJECT DESCRIPTION

Table with 2 columns: PROJECT TITLE, DURATION. Includes field for FACILITIES AFFECTED BY THE PROPOSED PROJECT.

Facilities affected by the proposed project: [ ] Owned by Riverport Authority [ ] Leased to:

Briefly describe the project, including operational and market need, and how the project will increase jobs and efficiency: (Text limited for accurate printing. Attach additional pages as needed.) Design and construction of new Spreader Bar and Coil Hooks for unloading wire coils from barges.

Select ONE: [ ] Applicant plans to use their own manpower, equipment, or materials on the project (Force Account). [ ] Applicant plans to competitively bid out all work related to the project.

Table with 3 columns: TRAFFIC, CURRENT, AFTER PROJECT. Rows include Trucks per day, Train cars per week, and Barges per week.

FOR KYTC USE ONLY. Includes fields for Date Received, Application Complete, Eligible Applicant?, Permits Needed?, WTAB Approval, Sec. Approval, Award Amount, Award Date, Notification of Award, MOA #, and Notice to Proceed.



**KENTUCKY RIVERPORT IMPROVEMENT (KRI) APPLICATION**

**SECTION 3: APPLICANT CASH MATCH**

<b>Cash Match Amount:</b>	<b>Match Percentage</b> (20% or more of Total Project cost is required.):	
	<b>AMOUNT</b>	
<b>SOURCE(S) OF CASH MATCH</b>	<b>SECURED</b>	<b>APPLIED</b>
	\$4,900.00	\$19,600.00
	\$0.00	\$0.00
	\$0.00	\$0.00

**SECTION 4: PERMITS AND APPROVALS**

	YES	NO
Has the applicant consulted with state and federal agencies (US Army Corps of Engineers, US Coast Guard, US Fish & Wildlife Service, KY Division of Water, KY Heritage Council, etc.)?	<input type="checkbox"/>	<input checked="" type="checkbox"/>
Has state and federal agency consultation determined permits are needed?	<input type="checkbox"/>	<input checked="" type="checkbox"/>
Have all required permits (environmental, encroachment, etc.) been obtained?	<input type="checkbox"/>	<input checked="" type="checkbox"/>

**SECTION 5: SUBMISSION CHECKLIST** (See guidance document for details.)

- Kentucky Riverport Improvement Application
- Statement of Work
- Scope of Work
- Purchase quote or cost estimate for the project
- Project Schedule/Timeline
- Certification of the ability to provide the minimum 20% match requirement
- Maps, aerial photos, drawings, and photographs, as needed
- Engineering plans, schematics, details, drawings of the proposed project, as needed
- Copies of all correspondence or evidence of consultation that has occurred with state & federal agencies, if applicable
- Annual Affidavit for Bidders, Offerors and Contractors from applicant
- Documentation of Port Planning

**SECTION 6: CERTIFICATION**

I have read the Riverport Improvement Project Guidance Document and understand and agree to abide by what is stated therein. I agree that incomplete applications, applications missing any of the above required supporting documents, or applications received after the deadline, will be deemed ineligible by Division staff without consideration for KRI funds and returned to applicant. I also hereby certify, subject to the provision of KRS 523.100 (unsworn falsification to authorities), that the above information is true and correct to the best of my knowledge.

PRINTED NAME & TITLE	SIGNATURE	DATE
Greg Curlin Executive Director		6-5-24

Completed applications and all required attachments must be submitted electronically in PDF format. Paper copies will not be accepted. Emailed applications must be received by the Division by date indicated in document. PDF copies shall be sent via email to [KYTC.ModalPrograms@ky.gov](mailto:KYTC.ModalPrograms@ky.gov)



## **HFCRA Spreader Bar and Coil Hooks Project**

### **Statement of Work**

**Project Title:** HFCRA Spreader Bar and Coil Hooks Project

**Project Grantee:** Hickman-Fulton County Riverport Authority

**County:** Fulton County

#### **Statement of Work:**

Design and construction of new Spreader Bar and Coil Hooks for unloading wire coils from barges.

Normal wear and tear on the Hickman-Fulton County Riverport Authority spreader bar and hooks has created the need to replace the current spreader bar and hooks. The plan is to design a new spreader bar and coil hooks for lifting different sizes of wire coils from barges. The current design of coil hooks is not compatible with the different sizes of wire coils that we receive at the riverport. The Riverport is looking to have designed an adjustable coil hook that can be adjusted to handle different lengths of coils.

The requirement will be to construct a new spreader bar with four adjustable coil hooks.

**Funding:** Hickman-Fulton County Riverport Authority - \$ 4,900.00

KRI Funding - \$ 19,600.00

**Budget:** The HFCRA will provide the remaining funding for the project. The HFCRA does not receive any county or city funding for the Riverport.

**Description:** New Spreader Bar and Coil Hooks for unloading wire coils from barges.

The plan is to design a new spreader bar and coil hooks for lifting different sizes of wire coils from barges. The current design of coil hooks is not compatible with the different sizes of wire coils that we receive at the riverport. The Riverport is looking to have designed an adjustable coil hook that can be adjusted to handle different lengths of coils.





## **HFCRA Spreader Bar and Coil Hooks Project**

### **Scope of Work**

#### **Work to be Done:**

Design and construction of new Spreader Bar and Coil Hooks for unloading wire coils from barges.

Normal wear and tear on the Hickman-Fulton County Riverport Authority spreader bar and hooks has created the need to replace the current spreader bar and hooks. The plan is to design a new spreader bar and coil hooks for lifting different sizes of wire coils from barges. The current design of coil hooks is not compatible with the different sizes of wire coils that we receive at the riverport. The Riverport is looking to have designed an adjustable coil hook that can be adjusted to handle different lengths of coils.

The requirement will be to construct a new spreader bar with four adjustable coil hooks.

#### **Summary of Estimated Costs:**

TOTAL:	\$ 24,500.00
KRI Request:	\$ 19,600.00
HFCRA Funding:	\$ 4,500.00



## **HFCRA Spreader Bar and Coil Hooks Project**

### **Cost Estimate**

**Project Title:** HFCRA Spreader Bar and Coil Hooks Project

**Project Grantee:** Hickman-Fulton County Riverport Authority

**County:** Fulton County

#### **Cost Estimate:**

Design and construction of new Spreader Bar and Coil Hooks for unloading wire coils from barges.

The plan is to design a new spreader bar and coil hooks for lifting different sizes of wire coils from barges. The current design of coil hooks is not compatible with the different sizes of wire coils that we receive at the riverport. The Riverport is looking to have designed an adjustable coil hook that can be adjusted to handle different lengths of coils.

The estimate will be to construct a new spreader bar with four adjustable coil hooks.

**Total Cost Estimate: \$24,500.00**

**Funding:** Hickman-Fulton County Riverport Authority - \$4,900.00

KRI Funding - \$19,600.00

**Budget:** The HFCRA will provide 20% of the funding for the project. The HFCRA does not receive any county or city funding for the Riverport.

**QUOTATION TRANSMITTAL**

**QUOTE REF:** 1608SB.406 - Hickman River Port

**SEND TO**

**NAME:** Greg Curlin

**DATE:** 5.16.2024

**COMPANY:** Hickman - Fulton County Riverport Authority

**CELL #** 270.627.6911

**E-MAIL:** [greg@hickmanriverport.com](mailto:greg@hickmanriverport.com)

**OFFICE #** 270.236.2563

**FROM:**

**NAME:** Bobby King

**CELL #** 731.446.2878

**E-MAIL:** [bking@greenfieldpi.com](mailto:bking@greenfieldpi.com)

**OFFICE #** 731.886.1500

**MODEL NUMBER:** \_\_\_\_\_

**RATING INFO.:** 25 Ton

PRODUCT DESCRIPTION	Strong back beam for coil handling "C" hooks	
ITEM	DESCRIPTION	PRICE
SB	<p>Strong back beam to handle 4 "C" hooks for unloading steel wire from barges. Beam can also be used as a conventional strong back with pad eyes on the bottom side of the beam.</p> <p>Beam and "C" hooks to be blasted, primed and painted - Vivid Yellow top coat.</p> <p><b>Capacity is to be 25 tons - 50,000 lbs</b></p> <p>Freight: To be picked up by customer when completed.</p>	\$ 8,700.00

**FREIGHT:** Freight is not included in this quotation \$ -

<b>QUANTITY: 1</b>	<b>PER UNIT TOTAL \$ 8,700.00</b>
	<b>ORDER TOTAL \$ 8,700.00</b>

**AVAILABILITY** 6 week ARO or less if possible.

**FREIGHT:** Freight is not included in this quotation

**FOB:** **PLANT:**  **DELIVERED:**

**NOTES:** Certified Load testing is the responsibility of customer if required.

**Bobby King**  
Sales

\*\*\*Please Note\*\*\*

\*\*This quotation may detail additional optional equipment that can be included or excluded per individual customer specification as desired.

\*\*Prices quoted do not include applicable taxes.

\*\*Terms are Net 30 pending Credit Application.

**QUOTATION TRANSMITTAL**

**QUOTE REF:** 1705SBHook.411 - Hickman River Port.001

**SEND TO**

**NAME:** Greg Curlin

**DATE:** 5.16.2024

**COMPANY:** Hickman - Fulton County Riverport Authority

**CELL #** 270.627.6911

**E-MAIL:** [greg@hickmanriverport.com](mailto:greg@hickmanriverport.com)

**OFFICE #** 270.236.2563

**FROM:**

**NAME:** Bobby King

**CELL #** 731.446.2878

**E-MAIL:** [bking@greenfieldpi.com](mailto:bking@greenfieldpi.com)

**OFFICE #** 731.886.1500

**MODEL NUMBER:** \_\_\_\_\_

**RATING INFO.:** 6,000 LBS

PRODUCT DESCRIPTION	"C" Hook for handling coil wire	
ITEM	DESCRIPTION	PRICE
C-hooks	<p>C-Hook for handling coiled wire from barged. Hooks will have moveable back spacer to change depth of lower tine. Allows two different coil lengths to be handled with the same hook.</p> <p>Hooks to be media blasted, primed with Vivid yellow top coat.</p> <p>Capacity is 6,000 LBS per hook.</p> <p>Freight: To be picked up by customer when completed.</p>	ea \$ 3,160.00

**FREIGHT:** Freight is not included in this quotation \$ -

**QUANTITY: 5** **PER UNIT TOTAL \$ 3,160.00**  
**ORDER TOTAL \$ 15,800.00**

**AVAILABILITY** 6 week ARO or less if possible.

**FREIGHT:** Freight is not included in this quotation

**FOB:** **PLANT:**  **DELIVERED:**

**NOTES:** Certified Load testing is the responsibility of customer if required.

**Bobby King**  
Sales

\*\*\*Please Note\*\*\*

\*\*This quotation may detail additional optional equipment that can be included or excluded per individual customer specification as desired.

\*\*Prices quoted do not include applicable taxes.

\*\*Terms are Net 30 pending Credit Application.



## **HFCRA Spreader Bar and Coil Hooks Project Schedule and Timeline**

1) Advertise for Bids from Contractors	August 1, 2024	August 15, 2024
2) Receive and Review Contractors Bids	August 15, 2024	August 26, 2024
3) Award Contract to Winning Contractor	August 27, 2024	
4) Estimated time for Construction	6 Weeks	October 4, 2024
5) Complete Project and Receive Spreader Bar/Coil Hooks		October 11, 2024





## Affidavit

I, Greg Curlin, do hereby certify that I am a duly appointed and qualified Director of the Hickman-Fulton County Riverport Authority organized and existing under the laws of the State of Kentucky and that I am authorized by the Board of Directors to execute these applications with the Kentucky Transportation Cabinet recognizing that this project includes a 20% matching fund obligation of the Riverport. I affirm that the Riverport is in such financial good standing as to possess the ability to meet the 20% match requirements.

Date: 05/23/2024

By: Greg Curlin

Title: Executive Director

PORT OF HICKMAN SPREADER BAR WITH BALE HOOKS  
 CAPACITY 1: 25 US TONS AT OUTER SHACKLE POINTS  
 CAPACITY 2: 3 US TONS AT EACH BALE HOOK  
 WEIGHT: 2,400 LB WITH BALE HOOKS INSTALLED

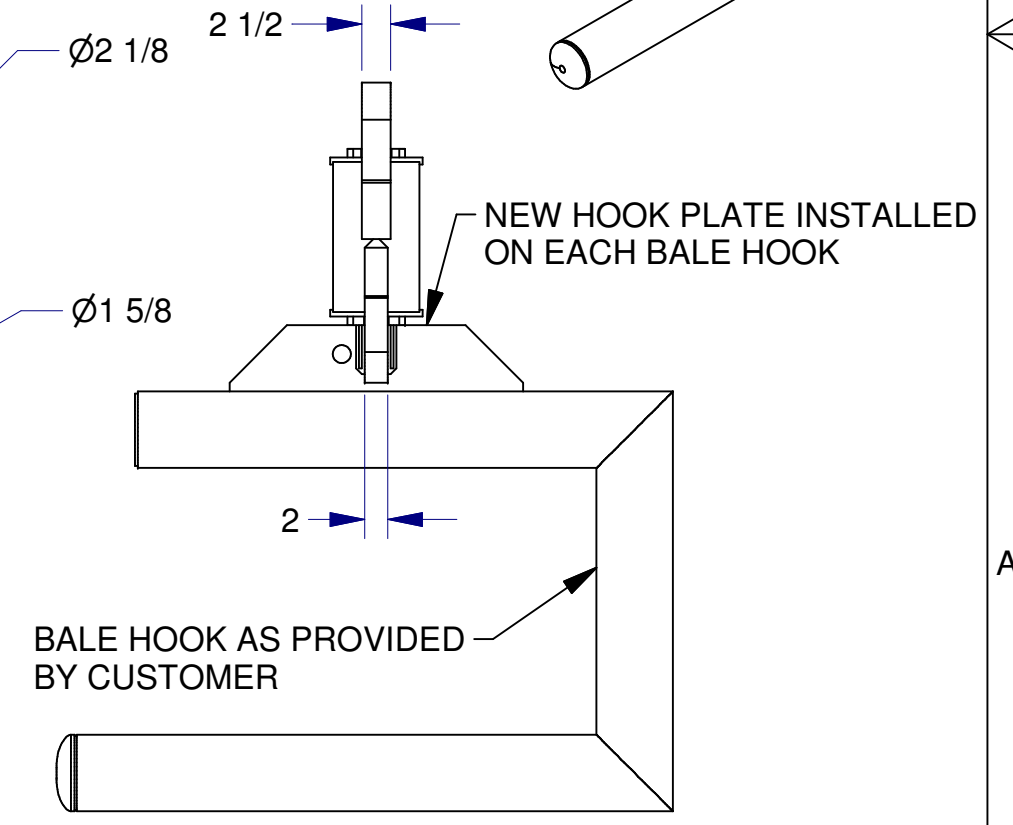
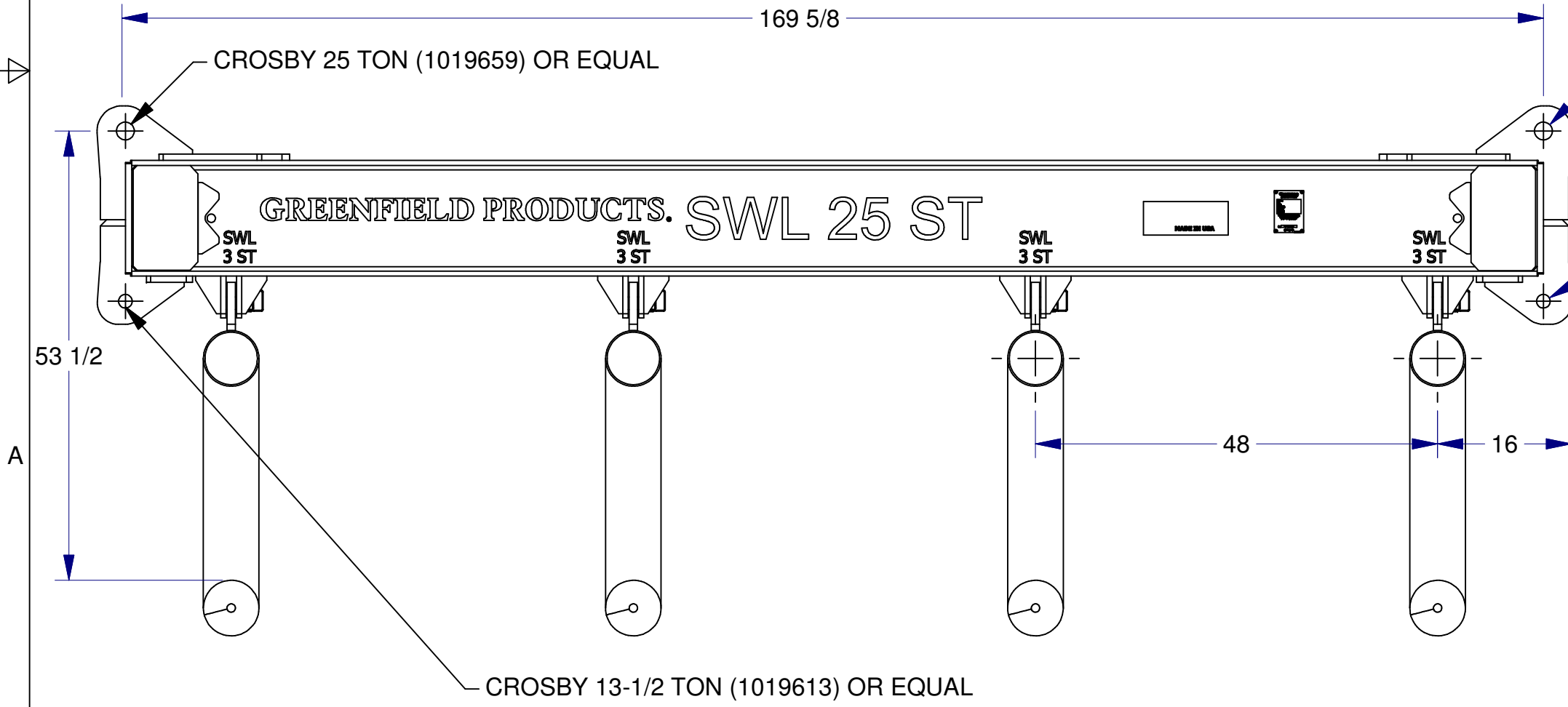
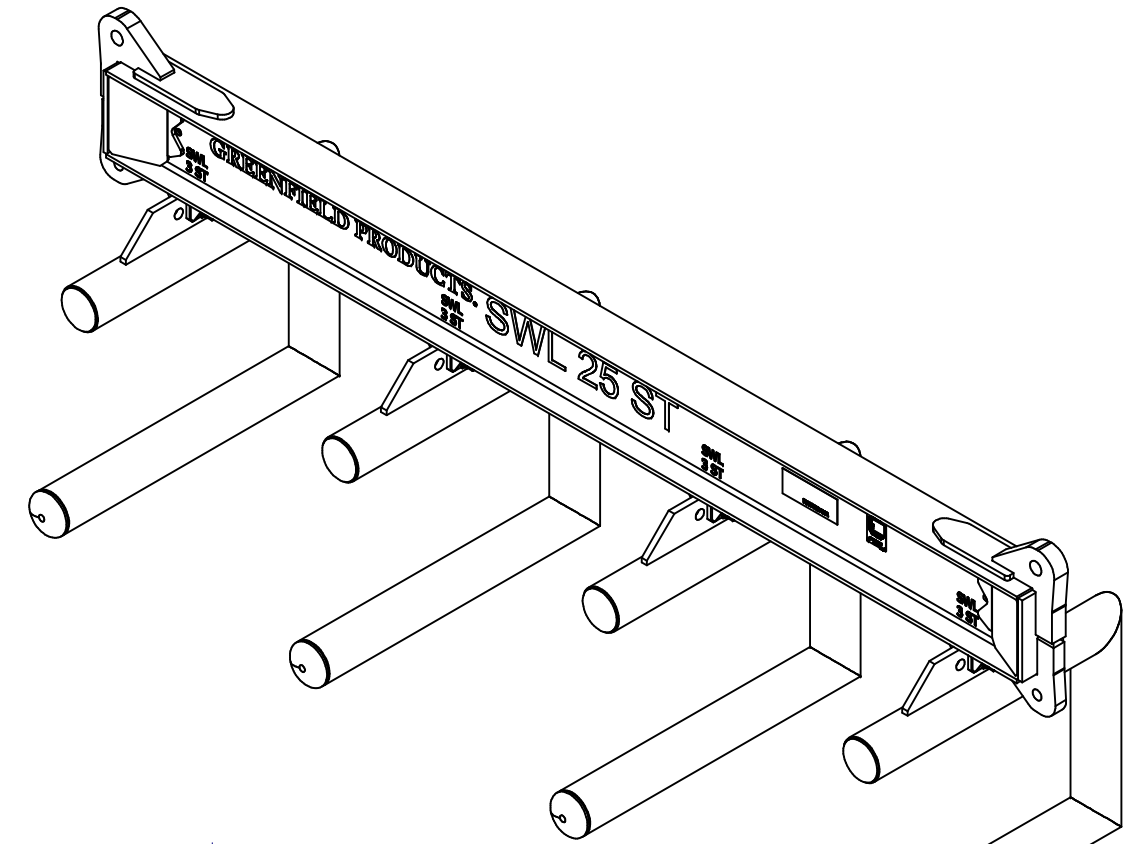

IT.	QTY	DESCRIPTION	PART NO.
1	1	SPREADER BEAM W.A. (50 TON, 10 FEET)	51-2357
2	1	PLATE, SERIAL NUMBER	51-2387
3	2	DECAL, "SWL 50 ST"	51-2392
4	2	DECAL, GREENFIELD PRODUCTS	99-1591
5	4	RIVET, POP (3/16 DIA X 1/2 LG)	900303

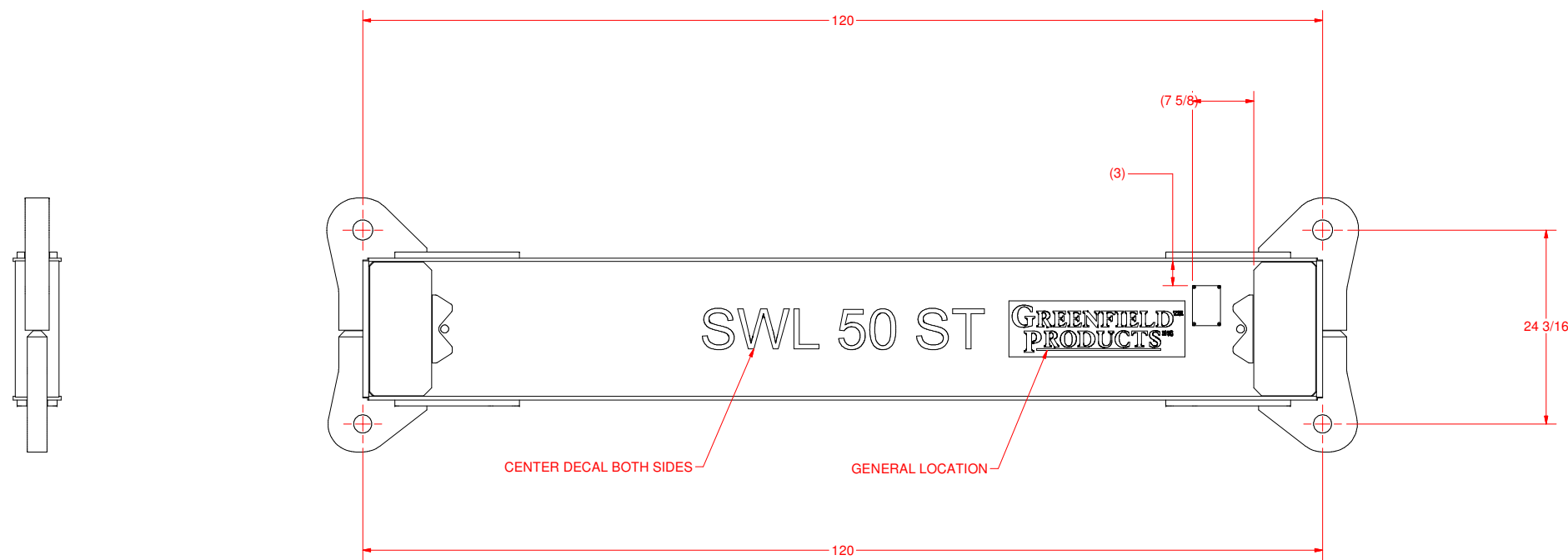
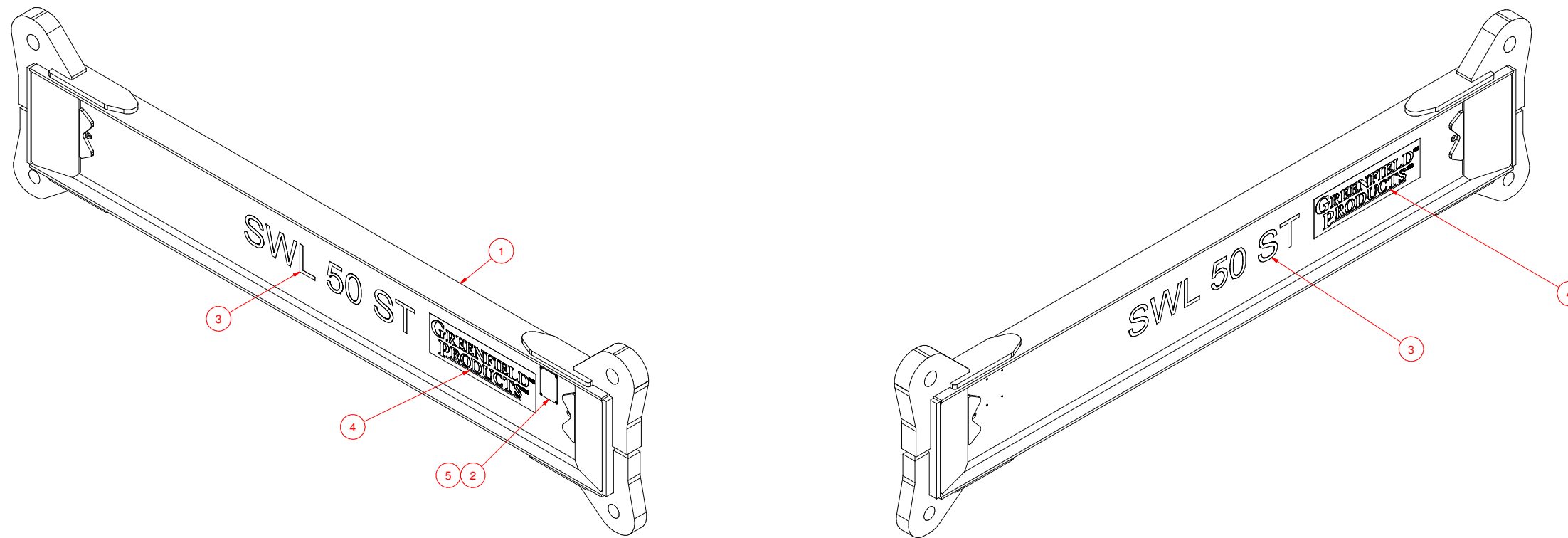

45° BRIDLE RATING WITH 50 TON TOTAL LIFTING CAPACITY  
 25 TON RATING AT TWO POINTS ON LOWER SHACKLE HOLES

HICKMAN SPREADER BAR  
RATING: 25 US TON AT OUTER LIFT POINTS  
RATING: 3 US TON AT EACH COIL LIFT POINT

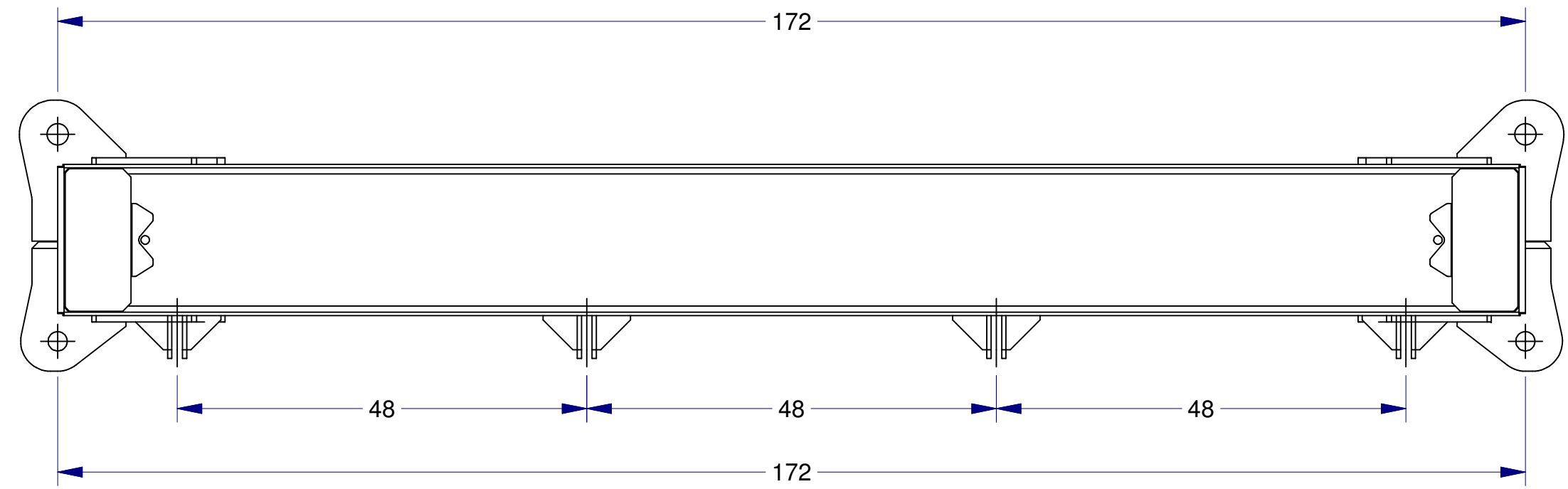
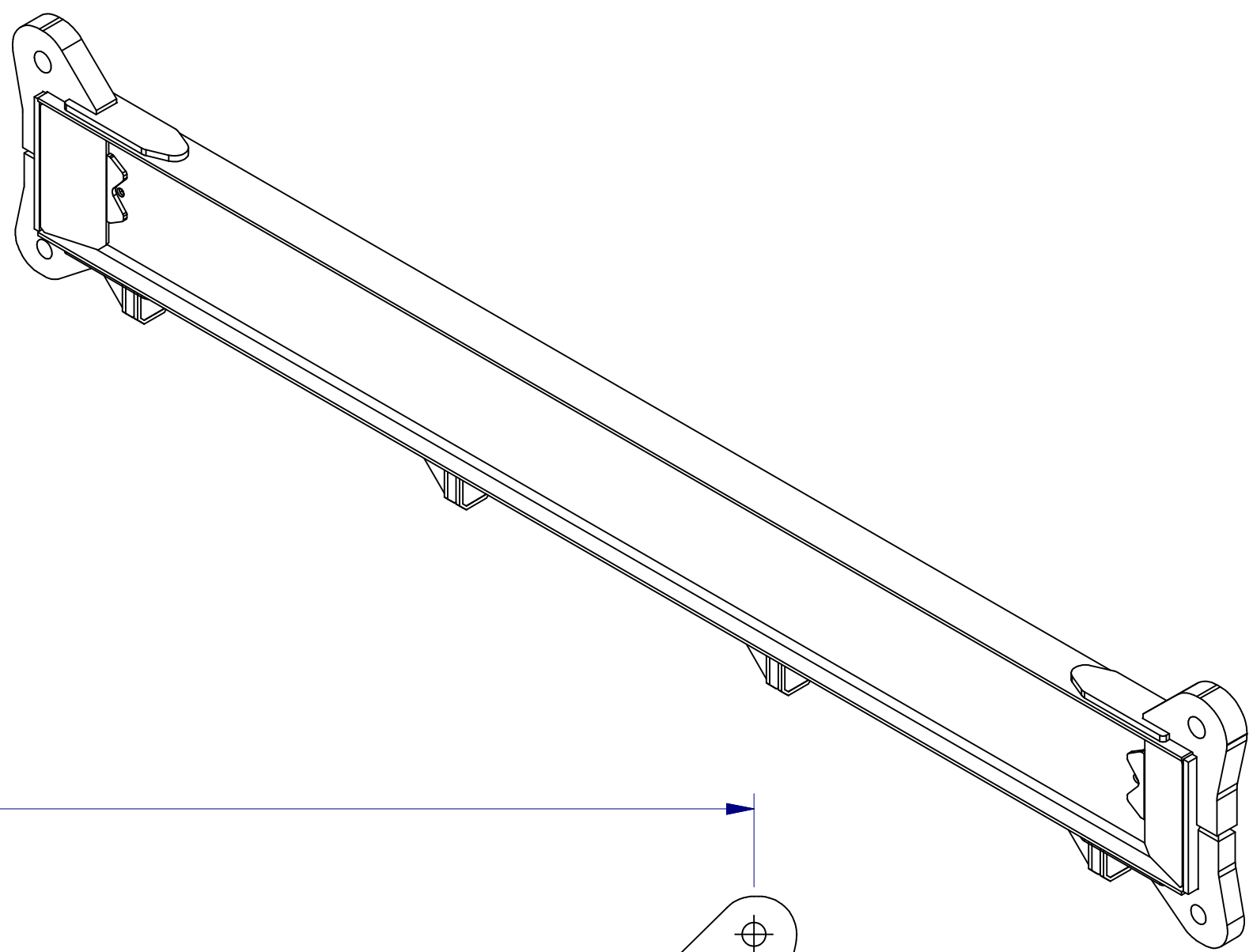

4

3

2

1

B

B

A

A

4

3

2

1

172

48

48

48

172

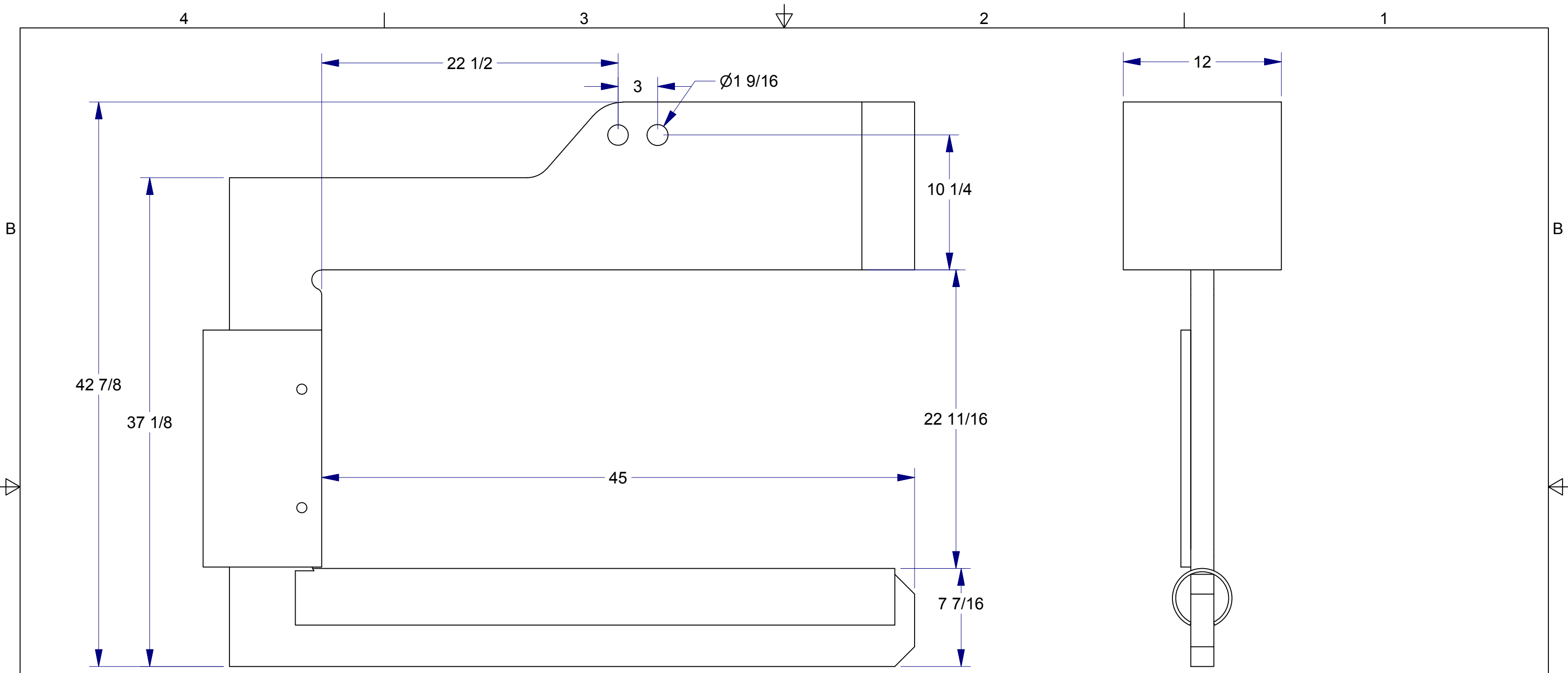

SHEET 1 OF 2

**PRELIM**

**GREENFIELD PRODUCTS** INC

TITLE **3T COIL HOOK**

THIS DRAWING MUST NOT BE USED UNTIL APPROVED FOR CONSTRUCTION. THIS DRAWING IS THE EXCLUSIVE PROPERTY OF GREENFIELD PRODUCTS INC. IT'S ACCEPTANCE CONSTITUTES AN AGREEMENT THAT IT SHALL BE TREATED AS A STRICTLY CONFIDENTIAL DOCUMENT AND IS TO BE RETURNED UPON REQUEST, AND IS NOT TO BE COMMUNICATED, DISCLOSED, OR COPIED EXCEPT AS EXPRESSLY AUTHORIZED IN WRITING BY GREENFIELD PRODUCTS INC.

PLOTING SCALE	
DRAWN BY <b>DVanderschaaf</b>	DATE
APPROVED BY	DATE

PART NO. <b>1705CHook.402</b>	REV. <b>A</b>
----------------------------------	------------------

ESTIMATED WEIGHT: 360 LBS

© 2007



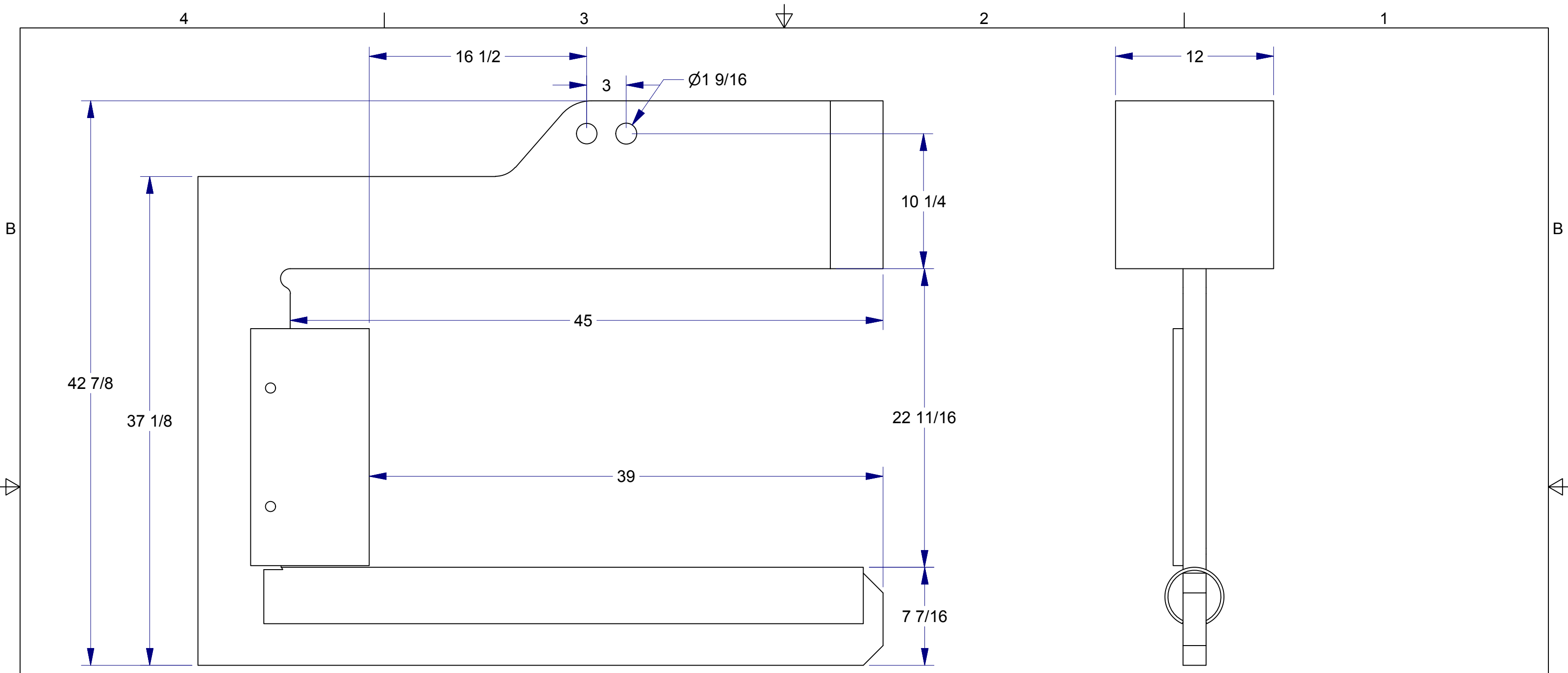

SHEET 2 OF 2

**PRELIM**

**GREENFIELD PRODUCTS** INC

TITLE **3T COIL HOOK**

THIS DRAWING MUST NOT BE USED UNTIL APPROVED FOR CONSTRUCTION. THIS DRAWING IS THE EXCLUSIVE PROPERTY OF GREENFIELD PRODUCTS INC. IT'S ACCEPTANCE CONSTITUTES AN AGREEMENT THAT IT SHALL BE TREATED AS A STRICTLY CONFIDENTIAL DOCUMENT AND IS TO BE RETURNED UPON REQUEST, AND IS NOT TO BE COMMUNICATED, DISCLOSED, OR COPIED EXCEPT AS EXPRESSLY AUTHORIZED IN WRITING BY GREENFIELD PRODUCTS INC.	PLOTING SCALE	
	DRAWN BY <b>DVanderschaaf</b>	DATE
	APPROVED BY	DATE
	PART NO. <b>1705CHook.402</b>	REV. <b>A</b>

ESTIMATED WEIGHT: 775 LBS

© 2007



GREENFIELD PRODUCTS SWL 25 ST

SWL  
3 ST

SWL  
3 ST

SWL  
3 ST

SWL  
3 ST

GREENFIELD  
PRODUCTS  
MADE IN USA





FIELD PRODUCTS SW

SWL  
3 ST







GREENFIELD PRODUCTS SWL 25 ST

GREENFIELD PRODUCTS  
MADE IN USA

SWL  
3 ST

SWL  
3 ST

SWL  
3 ST

SWL  
3 ST





## **HFCRA Spreader Bar and Coil Hooks Project**

**Copies of correspondence or consultation with state and federal agencies.**

Not applicable

Design and Purchase will be made by using State of Kentucky Bidding Requirements. Initial design work performed by local manufacturer.



Hickman Riverport  
Capital Improvement Projects  
2024 2025

6/6/2024

1	Grain Conveyor Replacement	\$4,500,000.00
2	Repairs to Dock Cells	\$550,000.00
3	New Loader to Replace Volvo Loader	\$275,000.00
4	Barge Access Walkway to Crane Barges	\$100,000.00
5	Warehouse Roof / Skylight Removal	\$20,000.00
6	Crane Wire Unloading Rack	\$25,000.00
7	Crane Bridge Hopper	\$75,000.00
8	New East Access Road connecting to Crane Bridge	\$250,000.00
9	Stokes Property and Gravel for Laydown area	\$200,000.00
10	Walkway for Barge Access on Crane Dock	\$250,000.00
11	New Wharf Project to move Crane and Unload Area	\$13,500,000.00
12	New Bulk Storage Warehouse	\$4,000,000.00
13	Climate Controlled Box Warehouse	\$1,750,000.00
14	Property Acquisition 'B' House	\$200,000.00
15	Conveyor Walkway to Truck Loading Cell	\$125,000.00
16	Paint Grain Conveyors	\$200,000.00
17	Dredging of Dock Cells as needed	\$75,000.00
18	Scale Access Paving Project	\$125,000.00
19	Grain Bin for loading Barges on Crane Side	\$500,000.00
20	New Tractor and Mower	\$40,000.00
21	Security Fence Upgrade	\$50,000.00
		\$26,810,000.00



### Required Affidavit for Bidders, Offerors and Contractors (KRS 45A.110 & 45A.115)

#### Affidavit Effective for One (1) Year from Date of Execution

**Instructions:** Pursuant to [KRS 45A.110](#) and [45A.115](#), a bidder, offeror, or contractor ("Contractor") is required to submit a Required Affidavit for Bidders, Offerors, and Contractors to be awarded a contract, or for the renewal of a contract. An authorized representative of the contracting party must complete the attestation below, have the attestation notarized, and return the completed affidavit to the Commonwealth.

#### Attestation

As a duly authorized representative for the Contractor, I swear and affirm under penalty of perjury, that that the Contractor has not knowingly violated campaign finance laws of the Commonwealth of Kentucky and that the award of a contract will not violate any provision of the campaign finance laws of the Commonwealth. For purposes of this attestation, "Knowingly" means that the bidder or offeror is aware or should have been aware of the existence of a violation. The bidder or offer understands that the Commonwealth retains the right to request an updated affidavit at any time.

Greg Curlin  
Signature

Greg Curlin

Printed Name

Executive Director  
Title

05/21/2024  
Date

Bidder or Offeror Name: Hickman-Fulton Co. Riverport Authority Inc.  
Address: 625 Catlett Street  
Hickman, Kentucky, 42050

Commonwealth of Kentucky Vendor Code (If known): KY0016208

Subscribed and sworn to before me this 21<sup>st</sup> day of May, 2024.

State of: Kentucky

Notary: Keleia McCloud

County of: Fulton

My Commission Expires: 3-19-25

