

VEHICULAR GATE (4' AND 6' HIGH FENCE)

~ NOTES ~

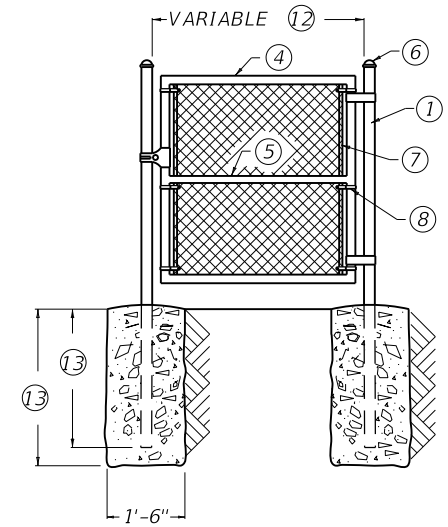

PEDESTRIAN GATE  
(4' AND 6' HIGH FENCE)

- ① 6' TO 13' WIDTH FOR SINGLE GATE OR 12' TO 26' WIDTH FOR DOUBLE GATE. SEE ELSEWHERE IN PLANS FOR GATE HEIGHT.
- ② 4' TO 6' WIDTH. SEE ELSEWHERE IN PLANS FOR GATE HEIGHT.
- ③ 3'-0" FOR 4' FENCE OR 3'-6" FOR 6' FENCE. 2'-6" FOR 4' FENCE OR 3'-0" FOR 6' FENCE.
- 14. ALL POST SHALL BE SET IN CONCRETE TO THE DIMENSIONS AS INDICATED ON THIS DRAWING.
- 15. VEHICULAR AND PEDESTRIAN GATES SHALL HAVE HEAVY PRESSED STEEL CORNERS SECURELY RIVETED OR SHALL BE MACHINE NOTCHED, AND ELECTRICALLY WELDED SO AS TO BE RIGID AND WATER TIGHT; AND EQUIPPED WITH A PADLOCKING DEVICE AND GROUND STOP.
- 16. ALL WELDED JOINTS SHALL BE CLEANED AND PAINTED WITH TWO ( 2 ) COATS OF ALUMINUM PAINT.
- 17. 4' HIGH GATES SHALL HAVE 4' FABRIC HEIGHT. 6' HIGH GATES SHALL HAVE 6' FABRIC HEIGHT. 8' HIGH GATES SHALL HAVE 7' FABRIC HEIGHT. 9' HIGH GATES SHALL HAVE 8' FABRIC HEIGHT. 10' HIGH GATES SHALL HAVE 9' FABRIC HEIGHT. 11' HIGH GATES SHALL HAVE 10' FABRIC HEIGHT. 12' HIGH GATES SHALL HAVE 11' FABRIC HEIGHT.
- 18. BARBED WIRE IS REQUIRED ON 8' TO 12' HIGH GATES. SEE DETAILS A AND B FOR INSTALLATION.
- 19. THE CONTRACTOR IS NOT TO ORDER GATES UNTIL THEIR NECESSITY AND LOCATION HAVE BEEN CERTIFIED BY THE ENGINEER.
- 20. ALL FENCE FITTINGS SHALL COMPLY WITH ASTM F626.
- 21. NPS = NOMINAL PIPE SIZE - ASTM F1083 AND ASTM F1043 (HEAVY INDUSTRIAL FENCE) SHALL GOVERN.

BID ITEMS AND UNIT TO BID

SINGLE VEHICULAR CHAIN LINK GATE	EACH
OR	
DOUBLE VEHICULAR CHAIN LINK GATE	EACH
OR	
PEDESTRIAN CHAIN LINK GATE	EACH
CONCRETE-CLASS B	CUYD

LEGEND / (ALTERNATES)

	TUBULAR	ROLL FORMED
①	END POST 2½" NPS	3½" X 3½"
②	END POST 2½" NPS	3½" X 3½"
③	GATE POST 3½" NPS	NO ALTERNATE
④	GATE FRAME 1½" NPS	NO ALTERNATE
⑤	1¼" NPS	NO ALTERNATE
⑥	APPROVED CAPS	NOT REQUIRED
⑦	FLAT TENSION BAR	NOT REQUIRED
⑧	BRACE BAND AND TENSION BAND	NOT REQUIRED
⑨	BARBED WIRE	BARBED WIRE
⑩	BARBED WIRE ARMS	BARBED WIRE ARMS

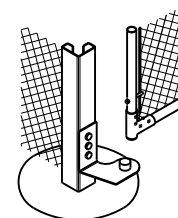

ROLL FORMED HINGE DETAIL

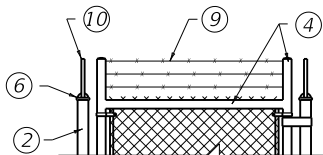

DETAIL "A"  
(8' TO 12' HIGH FENCE)



DETAIL "B"  
(8' TO 12' HIGH FENCE)

KENTUCKY  
DEPARTMENT OF HIGHWAYS

4' TO 12' HIGH  
CHAIN LINK GATE

STANDARD DRAWING NO. RFG-005-06

SUBMITTED	<i>[Signature]</i>	12-01-15
DESIGNED BY	DATE OF DESIGN	DATE
APPROVED	<i>[Signature]</i>	12-01-15
STATE HIGHWAY ENGINEER	DATE	DATE