

PLAN VIEW

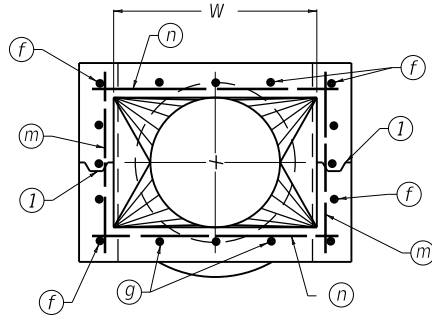

SECTION B-B

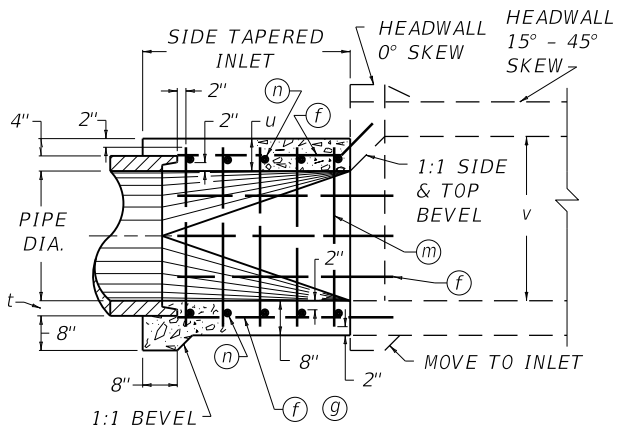

SECTION A-A

DIMENSIONS AND QUANTITIES

PIPE DIA.	30"	36"	42"	48"	54"	60"						
ELLIPT. EQUIV. HDWL. TO USE	42"	48"	54"	60"	66"	72"						
NO. 5 BARS	QTY.	LENGTH	QTY.	LENGTH	QTY.	LENGTH	QTY.	LENGTH	QTY.	LENGTH		
f	13	4'-2"	14	4'-2"	16	5'-2"	17	5'-2"	19	5'-2"	22	6'-2"
g	3	4'-2"	4	4'-2"	4	5'-2"	5	5'-2"	5	5'-2"	6	6'-2"
m	10	3'-6"	10	4'-0"	12	4'-6"	12	5'-0"	12	5'-8"	14	6'-2"
n1	2	3'-8"	2	4'-2"	2	4'-8"	2	5'-2"	2	5'-8"	2	6'-0"
n2	2	3'-11"	2	4'-6"	2	5'-0"	2	5'-6"	2	6'-0"	2	6'-4"
n3	2	4'-2"	2	4'-10"	2	5'-4"	2	5'-10"	2	6'-4"	2	6'-8"
n4	2	4'-6"	2	5'-2"	2	5'-8"	2	6'-2"	2	6'-8"	2	7'-0"
n5	2	4'-9"	2	5'-6"	2	6'-0"	2	6'-6"	2	7'-0"	2	7'-4"
n6	-	-	-	-	2	6'-4"	2	6'-10"	2	7'-4"	2	7'-8"
n7	-	-	-	-	-	-	-	-	-	-	2	8'-0"
LBS. STEEL	150	170	233	256	282	372						
CU. YD. CONC.	1.38	1.66	2.48	2.87	3.28	4.47						
L	4'-0"	4'-0"	5'-0"	5'-0"	5'-0"	6'-0"						
W	3'-11"	4'-7"	5'-4"	6'-1"	6'-9"	7'-6"						
Q	0'-6"	0'-8"	0'-10"	1'-0"	1'-2"	1'-6"						
u	0'-7½"	0'-8"	0'-8½"	0'-9"	0'-9½"	0'-10"						
v	3'-2"	3'-8"	4'-2"	4'-8"	5'-2"	5'-8"						
t	0'-3½"	0'-4"	0'-4½"	0'-5"	0'-5½"	0'-6"						

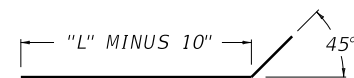

f BAR DETAIL

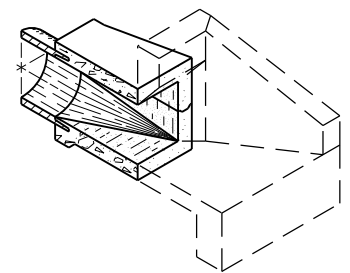

ISOMETRIC OF SECTION A-A
(0° SKEW HEADWALL SHOWN)

~ NOTES ~

- CONSTRUCTION JOINT PERMITTED.
- THIS INLET SHALL BE CONSTRUCTED IN ACCORDANCE WITH THE CURRENT STANDARD SPECIFICATIONS.
- SHOULD INLET DIMENSIONS CONFLICT WITH THOSE OF THE HEADWALL, THE INLET SHALL GOVERN.
- INLET QUANTITIES SHALL BE COMBINED WITH HEADWALL QUANTITIES. NOTES SHALL APPEAR ON THE PIPE DRAINAGE SUMMARY INDICATING THIS INCLUSION.
- THE INLET INTERIOR SHALL TAPER FROM A RECTANGULAR OPENING AT THE HEADWALL JUNCTION TO A CIRCULAR CONFIGURATION AT THE PIPE. (NOTE THE 1:1 TOP AND SIDE BEVELS TO BE CONSTRUCTED ON THE HEADWALL PORTION.)
- MINOR MODIFICATIONS IN THIS DESIGN, SUCH AS TRANSITIONING FROM ELLIPTICAL TO CIRCULAR, MAY BE MADE IF APPROVED IN WRITING BY THE ENGINEER.
- ENCIRCLED LETTERS INDICATE STEEL REINFORCING BAR LOCATIONS.
- FIVE PERCENT (5%) VERTICAL ELONGATION OF METAL PIPE SHALL BE ELIMINATED AND MADE ROUND FOR 48", 54", AND 60" PIPE WHERE IT JOINS THE INLET.

KENTUCKY
DEPARTMENT OF HIGHWAYS

SIDE TAPERED INLETS
30" TO 60" DIA.
ALL SLOPES - ALL SKEWS

STANDARD DRAWING NO. RDX-150-06

SUBMITTED *W. P. Galt* DIRECTOR, DIVISION OF DESIGN 12-01-15
DATE
APPROVED *W. P. Galt* STATE HIGHWAY ENGINEER 12-01-15
DATE