

~ NOTES ~

BID ITEM AND UNIT TO BID
 JUNCTION BOX EACH

1. THE CONTRACT UNIT PRICE EACH SHALL INCLUDE PAYMENT IN FULL FOR ALL MATERIALS, EXCAVATION, LABOR AND INCIDENTALS NECESSARY TO COMPLETE THE WORK.
- ② $H = D + t + 1'-0"$ FOR THE LARGEST PIPE INVOLVED.
3. STEEL REINFORCEMENT SHALL BE NO. 4 BARS PLACED 6" O.C.
- ④ THE MAXIMUM DEPTH OF THE BOX FROM THE FINAL GRADE TO FLOW LINE OF PIPE SHALL BE 8'-0". ANY BOXES DEEPER THAN 8'-0" SHALL BE SPECIFICALLY DESIGNED.
5. SEE CUR. STD. DWG. [RDX-002](#) FOR DIMENSIONS AND QUANTITIES.
6. FOR THIS APPLICATION THE "X" DIMENSION IS ASSUMED TO BE EQUAL TO OR GREATER THAN THE "Y" DIMENSION.
7. THE BOX SIZE NUMBER IS TO BE SHOWN ON THE PLANS AND SHALL BE DETERMINED BY THE LARGEST PIPE IN THE "X" OR "Y" DIMENSION.
- ⑧ TO ELIMINATE FORM REMOVAL, THE TOP SHALL BE PRECAST.

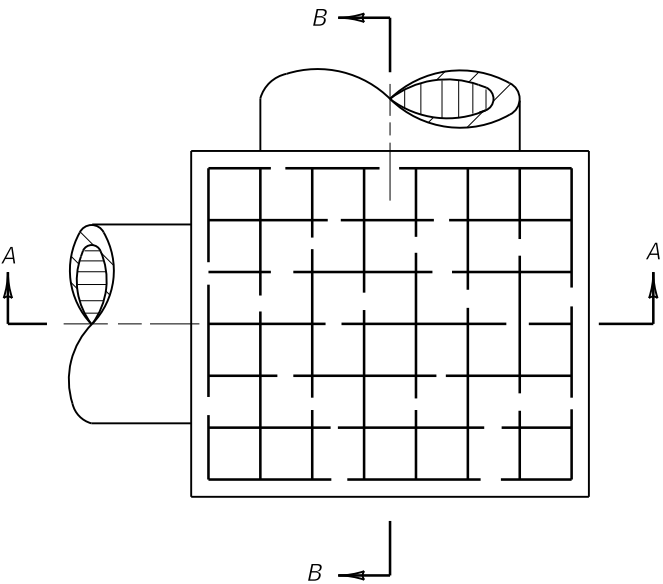

PLAN VIEW

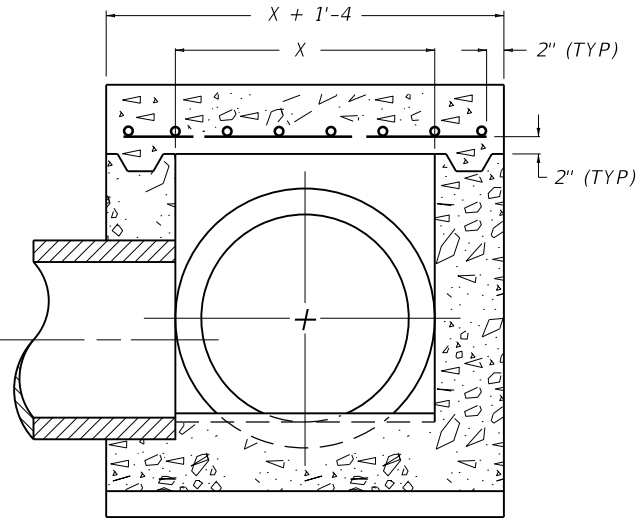

SECTION A-A

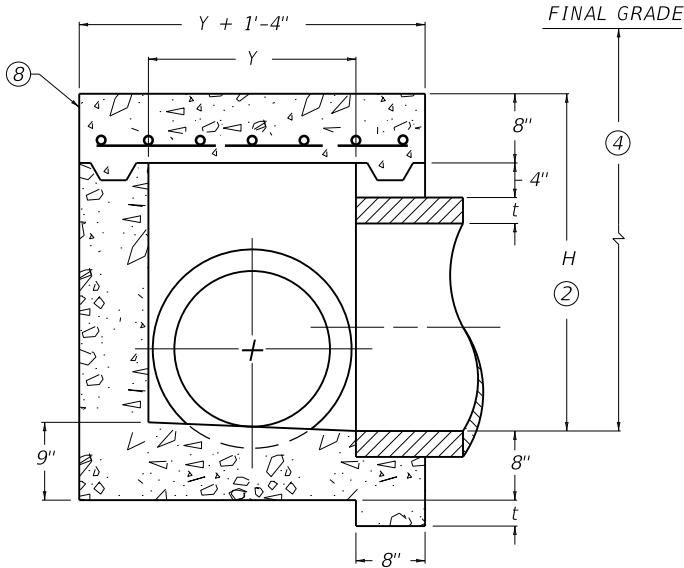

SECTION B-B

USE WITH CUR. STD. DWG.
[RDX-002](#)

KENTUCKY DEPARTMENT OF HIGHWAYS	
JUNCTION BOX	
STANDARD DRAWING NO. RDX-001-06	
SUBMITTED <i>[Signature]</i> DIRECTOR, BUREAU OF DESIGN	12-01-15 DATE
APPROVED <i>[Signature]</i> STATE HIGHWAY ENGINEER	12-01-15 DATE