

~ NOTES ~

BID ITEM AND UNIT TO BID
PAVED DITCH TYPE 2

SQYD

- ① ROADWAY EXCAVATION SHALL BE PAID FROM THE TOP OF THE PAVED DITCH SLAB TO THE ORIGINAL GROUND. THE EXCAVATION FROM THE TOP OF THE CONCRETE OF THE PAVED DITCH DOWN, WILL BE INCLUDED IN THE PRICE PAID FOR THE PAVED DITCH INCLUDING THE EXCAVATION FOR THE INTERMEDIATE AND END ANCHORS, AND NO DIRECT PAYMENT WILL BE MADE FOR THIS EXCAVATION.
2. ESTIMATE 0.032 CU. YDS. CLASS A CONCRETE PER LINEAR FT. OF PAVED DITCH AND 0.060 CU. YDS. CLASS A CONCRETE PER ANCHOR BASED ON MINIMUM DIMENSIONS SHOWN ON THIS DRAWING.
3. THE SECTION SHOWN WITHIN THE MINIMUM DIMENSION IS ESTIMATED AT 0.30 SQ. YD. PER LIN. FT.
4. COMPACTION, FINISHING AND CURING SHALL BE THE SAME AS REQUIRED FOR CONCRETE SIDEWALK.
5. IF THE CONTRACTOR ELECTS TO USE A CONSTRUCTION JOINT IN THE POURING OF THE PAVED DITCH, IT SHALL BE CONSTRUCTED AS DETAILED.
6. ANY LENGTH OF LONGITUDINAL REINFORCING STEEL WILL BE PERMITTED PROVIDED A 1'-0" LAP IS USED IN THE SPLICE. ADEQUATE TIES AT THE SPLICE SHALL BE REQUIRED.

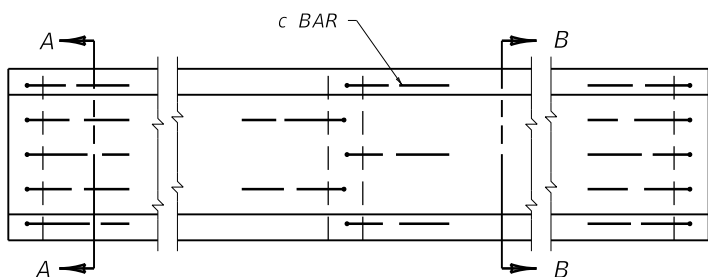

PLAN VIEW

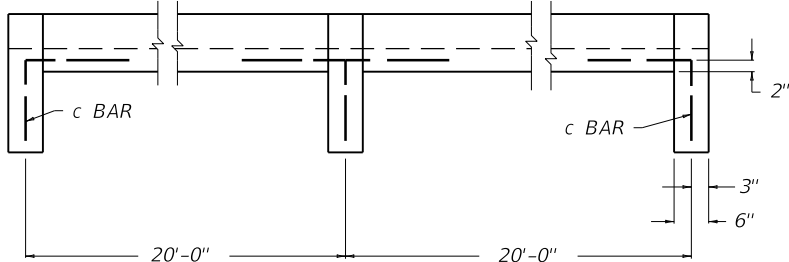

ELEVATION VIEW

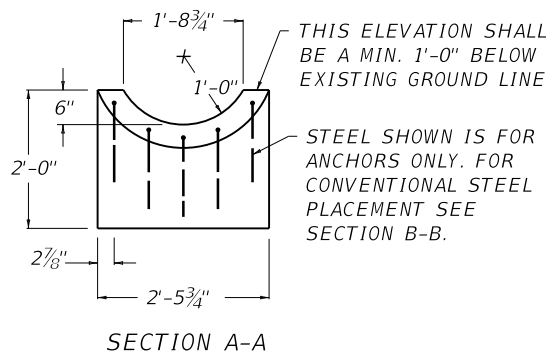

SECTION A-A

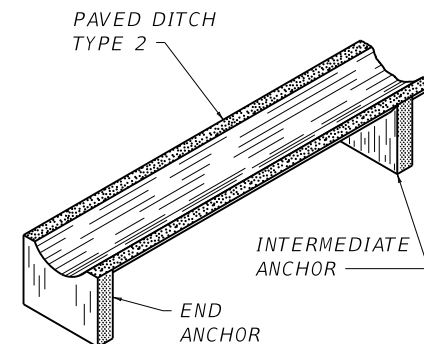

ISOMETRIC VIEW

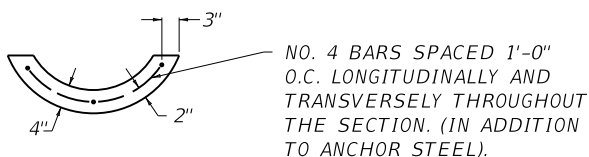

SECTION B-B

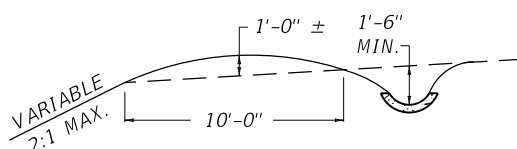

TYPICAL PAVED DITCH
(INTERCEPTOR DITCH)

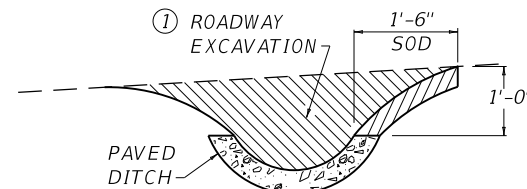

SHOULD THE TERRAIN OF THE EXISTING GROUND BE SO THAT WATER WOULD DRAIN INTO THE DITCH FROM BOTH SIDES, THEN SODDING WILL BE REQUIRED ON BOTH SIDES OF THE DITCH.

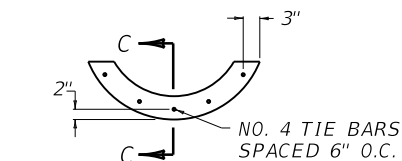

TIE BAR SECTIONAL VIEW

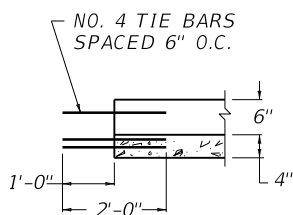

SECTION C-C

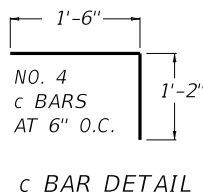

c BAR DETAIL

APPROX. STEEL QUANTITIES FOR MINIMUM SECTION SHOWN	
END ANCHORS (EACH)	8.90 LBS.
INTERMEDIATE ANCHORS (EACH)	8.90 LBS.
CONSTRUCTION JOINTS (EACH)	6.68 LBS.
BARS PER SQ. YD. OF DITCH	12.47 LBS.

KENTUCKY
DEPARTMENT OF HIGHWAYS

PAVED DITCH
TYPE 2

STANDARD DRAWING NO. RDD-002-07

SUBMITTED *W. P. Seal* 12-01-15
DATE
APPROVED *W. P. Seal* 12-01-15
DATE
STATE HIGHWAY ENGINEER