

PLAN VIEW

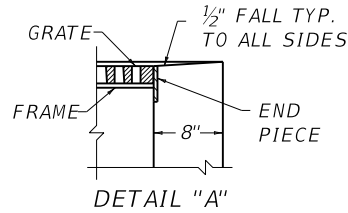

DETAIL "A"

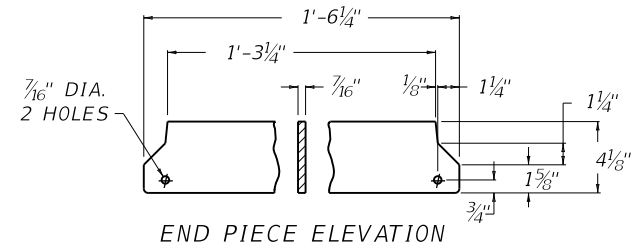

END PIECE ELEVATION

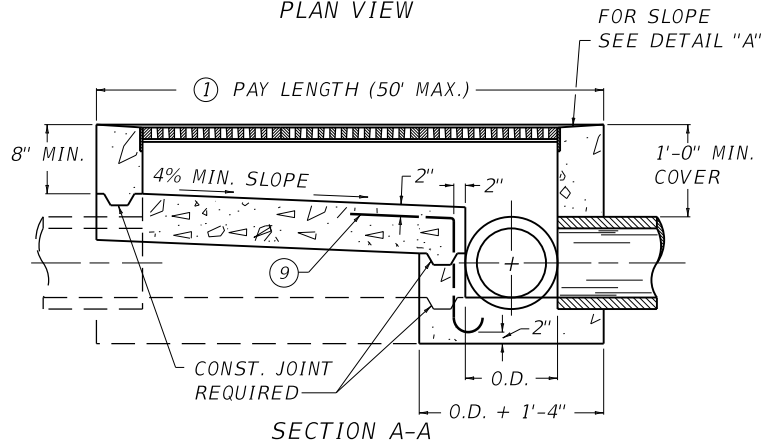

SECTION A-A

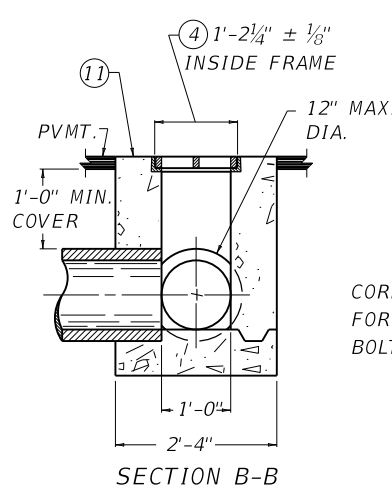

SECTION B-B

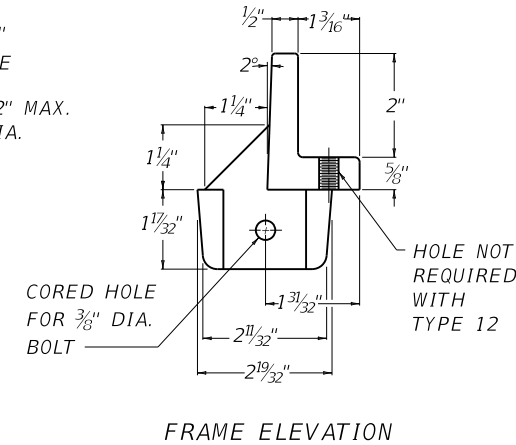

FRAME ELEVATION

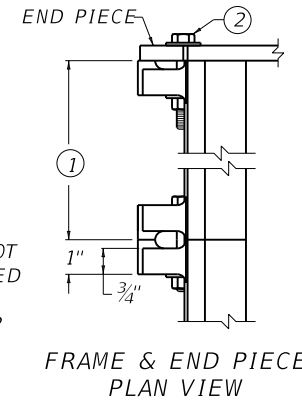

FRAME & END PIECE PLAN VIEW

~ NOTES ~

BID ITEM AND UNIT TO BID
 DROP BOX INLET TYPE 12 LF
 DROP BOX INLET TYPE 12A LF

12 WHEN THE GRATES ARE NOT TO BE BOLTED TO THE FRAME.
 12A WHEN THE GRATES ARE TO BE BOLTED TO THE FRAME.

- ① THE UNIT LENGTHS ARE 3'-0" FOR THE FRAMES AND 1'-11 7/8" FOR THE GRATES AND ARE TO BE CONSTRUCTED IN MULTIPLE LENGTHS OF 6'-0" FOR TYPE 12 INLET. THE UNIT LENGTHS ARE 2'-0" FOR THE FRAMES AND 1'-11 7/8" FOR THE GRATES AND ARE TO BE CONSTRUCTED IN MULTIPLE LENGTHS OF 2'-0" FOR TYPE 12A INLET.
- ② THE FRAME AND END PIECES SHALL BE ASSEMBLED WITH 3/8" X 2 1/2" HEX HEAD BOLTS, NUTS AND FLAT WASHERS (COMMERCIAL QUALITY).
- ③ WHEN DROP BOX INLET TYPE 12A IS A BID ITEM, THE GRATES SHALL BE BOLTED TO THE FRAME WITH FOUR 3/8"-16 X 2" STAINLESS STEEL HEX BOLTS AND FLAT WASHERS (COMMERCIAL QUALITY).
- ④ THIS IS A CONTROL DIMENSION TO PREVENT FRAME FROM SPREADING.
- 5. THE WALLS AND BASE OF THE STRUCTURE SHALL BE 8" THICK.
- 6. SEE PIPE SECTIONS IN THE PLANS FOR FLOW LINE ELEVATIONS, PIPE SIZES, AND OTHER PERTINENT DETAILS.
- 7. SECURITY DEVICES ARE REQUIRED FOR TYPE 12 ONLY.
- 8. APPROXIMATE WEIGHT OF CASTINGS:
 FRAME 15 LBS. PER FT. (BOTH SIDES)
 GRATE 50 LBS. PER FT.
- ⑨ TOP SLOPE OF INLET SHALL BE CONSTRUCTED TO MATCH SLOPE OF ADJACENT PAVEMENT.
- 12. THESE GRATES ARE BICYCLE FRIENDLY.

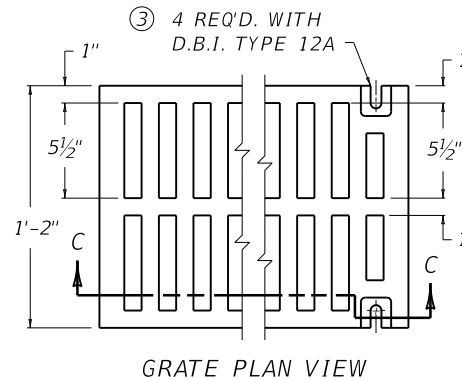
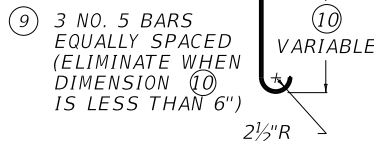

GRATE PLAN VIEW

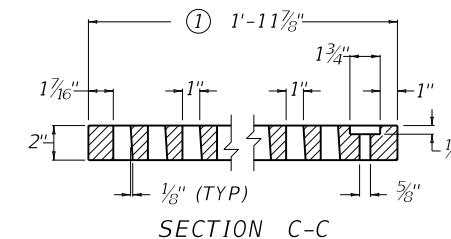

SECTION C-C

VARIATIONS OF DRAINAGE PATTERNS

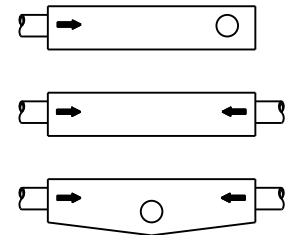

COMBINATIONS OF THE ABOVE MAY BE REQUIRED (SEE PIPE SECTIONS FOR APPROPRIATE DETAILS)

KENTUCKY DEPARTMENT OF HIGHWAYS

DROP BOX INLET TYPE 12 OR 12A

STANDARD DRAWING NO. RDB-012-10
 SUBMITTED *[Signature]* 12-01-15
 APPROVED *[Signature]* 12-01-15
 STATE HIGHWAY ENGINEER DATE