

PLAN VIEW

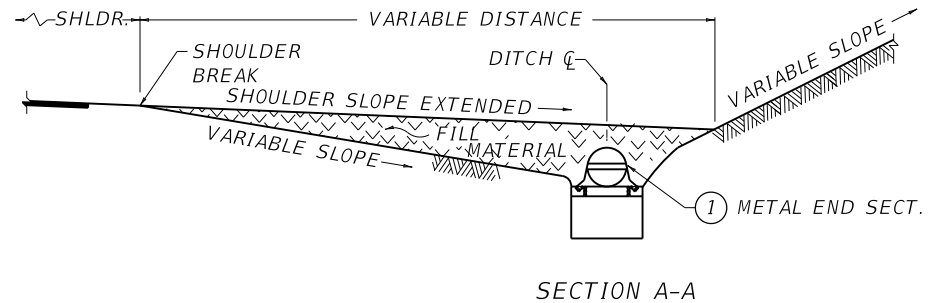

SECTION A-A

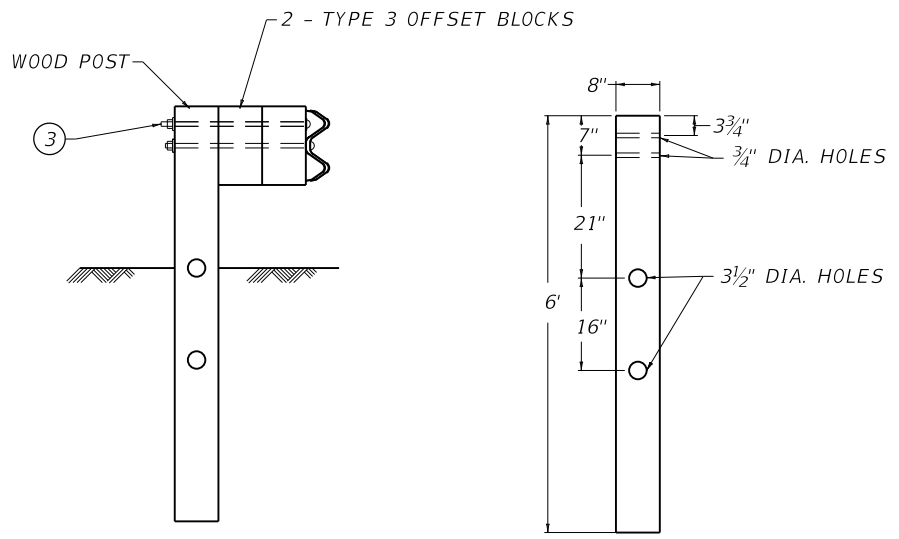

6" X 8" CRT WOOD POST
W/ 2 OFFSET BLOCKS

6" X 8" CRT WOOD POST

- ~ NOTES ~
- BID ITEMS AND UNIT TO BID
 - CHANNEL LINING CLASS II TON
 - END ANCHOR CUYD
 - PIPE LF
 - METAL END SECTION EACH
 - SEE CURRENT STANDARD DRAWING [RBR-030](#) FOR OTHER BID ITEMS.
 - ① SEE CURRENT STANDARD DRAWING [RDB-150](#) AND [RDB-160](#) FOR METAL END SECTIONS.
 - ② A MINIMUM DISTANCE OF 5'-0" BEHIND THE RAIL SHALL BE CLEAR OF ANY FIXED OBJECT HAZARDS.
 - ③ 1 - 5/8" DIA. BOLT WITH TWO ROUND WASHERS.
 - ④ SEE CURRENT STANDARD DRAWING [RBR-032](#) FOR ALTERNATE END ANCHOR.

USE WITH CUR. STD. DWGS.
[RBR-030](#) [RBR-032](#) [RDB-150](#)
[RDB-160](#) [RDX-060](#) [RDX-065](#)

KENTUCKY DEPARTMENT OF HIGHWAYS	
GUARDRAIL END TREATMENT TYPE 3 PIPE DRAINAGE DETAIL	
STANDARD DRAWING NO. RBR-031-01	
SUBMITTED <i>[Signature]</i> <small>DIRECTOR OF DESIGN</small>	12-01-15 <small>DATE</small>
APPROVED <i>[Signature]</i> <small>STATE HIGHWAY ENGINEER</small>	12-01-15 <small>DATE</small>