

5/8" BUTTON HEAD BOLT AND RECESSED NUT

- ~ NOTES ~
- ① RAIL BOLT SIMILAR EXCEPT LENGTH.
 - ② THE THRIE BEAM TO "W" BEAM CONNECTOR SHALL COMPLY WITH AASHTO M-180 CLASS A, TYPE 2 EXCEPT WHERE IT IS IN CONFLICT WITH THIS DETAIL.
- BID ITEM AND UNIT TO BID
THRIE BEAM TO W BEAM CONNECTOR EACH

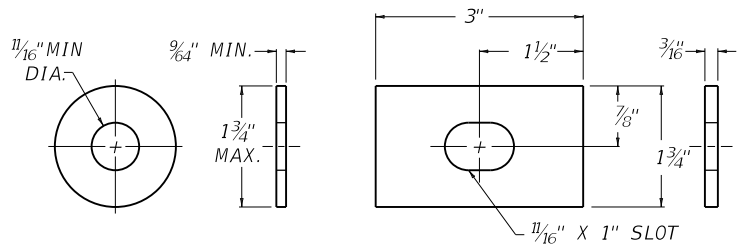

ROUND WASHER AND RECTANGULAR PLATE WASHER

SEE CUR. STD.
DWG. RBR-001
FOR DIMENSIONS

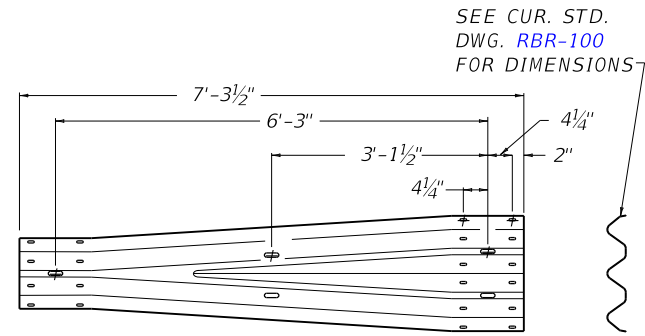

SEE CUR. STD.
DWG. RBR-100
FOR DIMENSIONS

THRIE BEAM TO "W" BEAM CONNECTOR ②

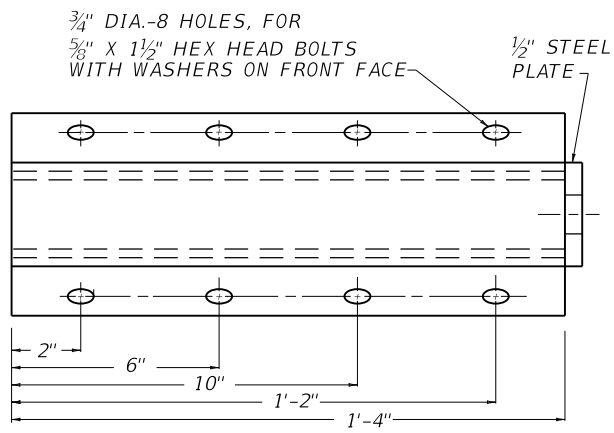

RAIL ANCHOR ASSEMBLY

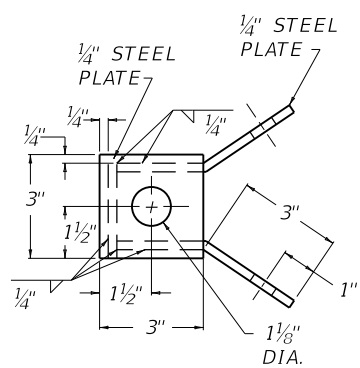

ALTERNATE NO. 1

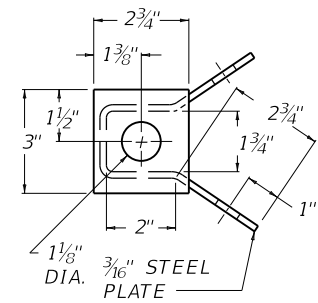

ALTERNATE NO. 2

USE WITH CUR. STD. DWG.
RBR-001 RBR-100

KENTUCKY DEPARTMENT OF HIGHWAYS	
GUARDRAIL COMPONENTS	
STANDARD DRAWING NO. RBR-005-11	
SUBMITTED	12-01-15
DESIGNED BY	DATE
APPROVED	12-01-15
STATE HIGHWAY ENGINEER	DATE