

~ NOTES ~

BID ITEM AND UNIT TO BID:  
 CONCRETE MEDIAN BARRIER TYPE  $\oplus$   $\oplus$   $\star$  LF

$\oplus$  9, 12, OR 14 DEPENDING ON "W"

$\oplus$  A, B, C, D OR E DEPENDING ON PAVEMENT APPLICATION.

$\star$  1 = SOLID SEGMENT - DENOTES BARRIER WALL WITH:

a. TRANSITION FROM "W" WIDTH TO MAX. WIDTH OF 4'.

b. CONSTANT WIDTH WALL GREATER THAN "W" WIDE BUT NOT GREATER THAN 4' WIDE. (EX.: WALL BETWEEN BRDG. PIERS).

2 = SEPARATE SEGMENT

THE METHOD OF MEASUREMENT FOR CONCRETE MEDIAN BARRIER FOR EACH TYPE WILL BE IN LINEAR FEET MEASURED ALONG THE TOP CENTERLINE OF THE BARRIER.

- TRANSITION CONDITION NO. 1, 2 AND 3 ALONG WITH SYMMETRICAL AND ASYMMETRICAL BARRIER SECTIONS ARE DEPICTED ON THIS DRAWING FOR ILLUSTRATION PURPOSES ONLY AT STRUCTURES AND FIXED OBJECTS. (SEE PLANS FOR ADDITIONAL DETAILS)
- ALL PAVEMENT, FILL MATERIAL, PIPE DRAINAGE (EXCLUSIVE OF WEEP HOLE PIPE) PLACED BETWEEN SEGMENTS OF THE BARRIER SHALL BE SHOWN SEPARATELY OR INCLUDED WITH OTHER LIKE PAY ITEMS ON THE PROJECT.
- FOR APPLICATION DETAILS TO NEW OR EXISTING PAVEMENT SEE CUR. STD. DWG. **RBM-001**.
- SEE ELSEWHERE IN PLANS FOR SIZE, LOCATION AND PAYMENT FOR RACEWAY WHEN REQUIRED.
- 4" PIPE FOR WEEP HOLES SPACED ON 20' CENTERS AND STAGGERED 10' WITH EACH WALL.

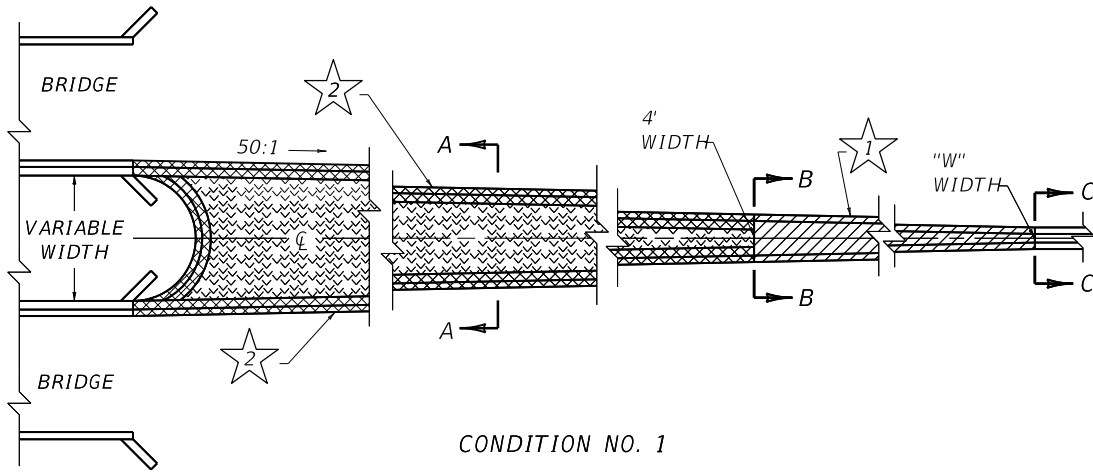

CONDITION NO. 1

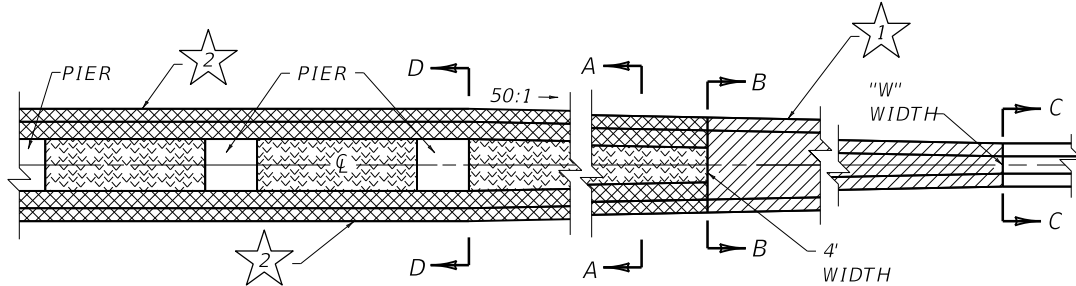

CONDITION NO. 2

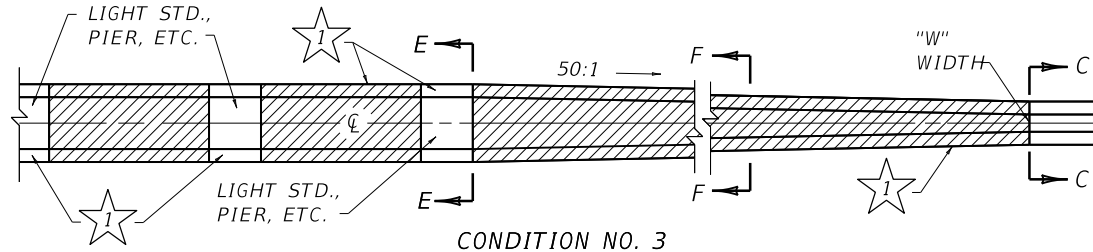

CONDITION NO. 3

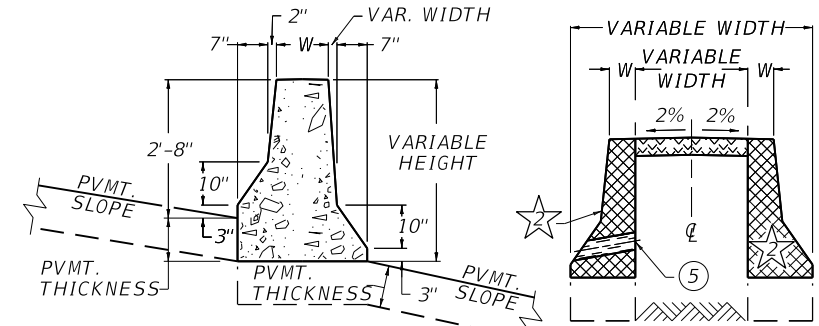

ASYMMETRICAL WALL SECTION

SECTION A-A

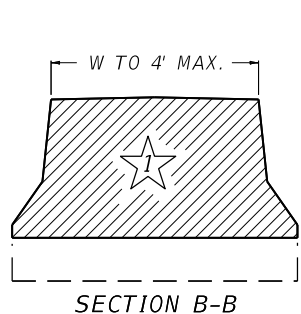

SECTION B-B

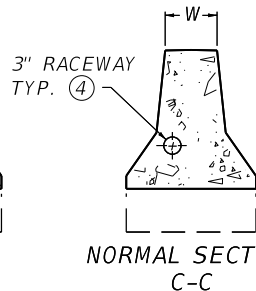

NORMAL SECTION C-C

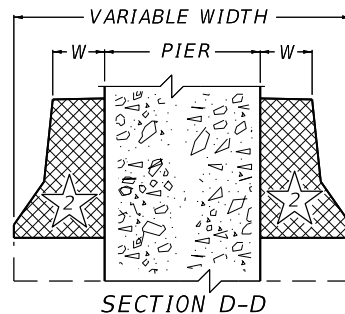

SECTION D-D

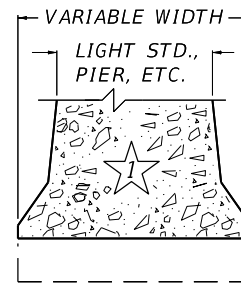

SECTION E-E

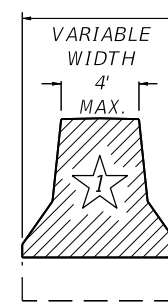

SECTION F-F

VARIABLE WIDTH USE WITH CUR. STD. DWG. **RBM-001**

KENTUCKY DEPARTMENT OF HIGHWAYS		
CONCRETE MEDIAN BARRIER SYMMETRICAL & ASYMMETRICAL SEPARATE & TRANSITION DETAILS		
STANDARD DRAWING NO. <b>RBM-015-06</b>		
SUBMITTED	<i>[Signature]</i>	12-01-15
APPROVED	<i>[Signature]</i>	12-01-15
	DATE	DATE