

PLAN VIEW

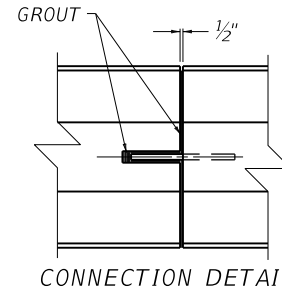

CONNECTION DETAIL

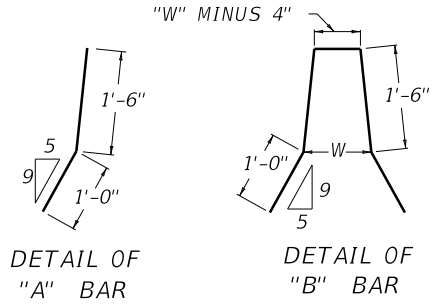

DETAIL OF "A" BAR

DETAIL OF "B" BAR

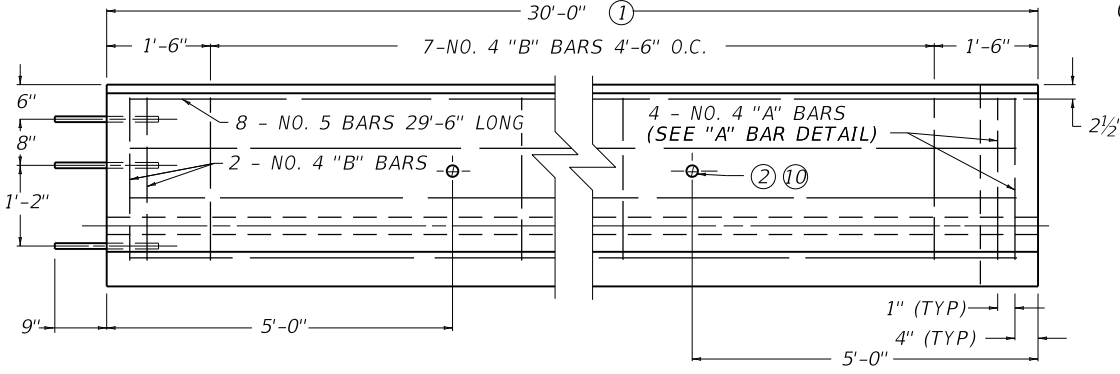

ELEVATION VIEW

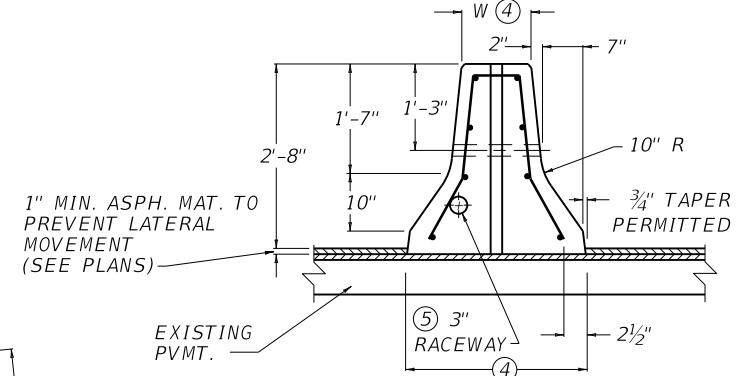

RIGHT ELEVATION VIEW

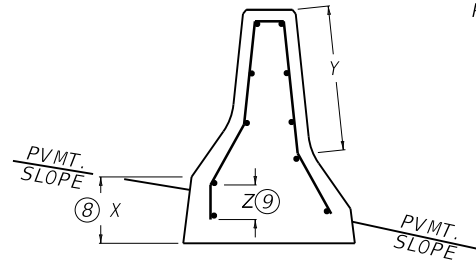

STEEL PLACEMENT FOR ASYMMETRICAL WALL SECTION

APPROX. REINF./30' SECTION
289 LBS.

APPROX. CU. YD. CONC./LIN. FT.

9" WIDE TOP = 0.14
12" WIDE TOP = 0.16
14" WIDE TOP = 0.17

APPROX. WEIGHT/30' SECTION
BASED ON 150 LBS./CU. FT.

9" WIDE TOP = 8.1 TONS
12" WIDE TOP = 9.7 TONS
14" WIDE TOP = 10.6 TONS

~ NOTES ~

NOT FOR NEW CONSTRUCTION. ONLY USE FOR REPAIRING OR RESTORING EXISTING HARDWARE.

BID ITEM AND UNIT TO BID:
CONCRETE MEDIAN BARRIER TYPE \oplus \oplus LF

\oplus 9 OR 12 OR 14 DEPENDING ON "W".
 \oplus D OR E DEPENDING ON PAVEMENT TYPE. (SEE CUR. STD. DWG. RBM-001 FOR TYPE).

- ① SHORTER SECTIONS MAY BE PERMITTED IF APPROVED IN WRITING BY THE ENGINEER.
- ② 2" DIA. LIFTING HOLE - 2 REQUIRED AT EACH SECTION. FORMED WITH 2" P.V.C. PIPE OR EQUAL.
3. SEE ELSEWHERE IN THE PLANS FOR BASE REQUIREMENTS.
- ④ 9" WIDE TOP WITH 2'-3" WIDE BASE OR 12" WIDE TOP WITH 2'-6" BASE. 14" WIDE TOP WITH 2'-8" WIDE BASE. (TAPER NOT INCLUDED IN BASE WIDTH).
- ⑤ THE RACEWAY SHALL BE TIED TO EACH OF THE "A" AND "B" BARS TO PREVENT SAG. SEE ELSEWHERE IN THE PLANS FOR SIZE, LOCATION, AND PAYMENT FOR RACEWAY WHEN REQUIRED.
6. PLACE ALL STEEL REINFORCEMENT A CLEAR DISTANCE OF 2" MIN. FROM OUTSIDE FACE OF WALL, EXCEPT WHERE SHOWN OTHERWISE.
7. SHOP DRAWINGS SHALL BE APPROVED PRIOR TO MANUFACTURE.
- ⑧ WHEN THE "X" DIMENSION EQUALS 10" THE BAR SHALL BE TURNED DOWN 6" ("Z" DIMENSION) AND AN ADDITIONAL LONGITUDINAL BAR SHALL BE ADDED AT THE BOTTOM OF THE TURN DOWN ("Z" DIMENSION) AND TO THE "Y" PORTION OF THE BAR. FOR EACH 6" INCREMENT OF THE "X" DIMENSION ABOVE 10" AN ADDITIONAL LONGITUDINAL BAR SHALL BE ADDED IN THE "Z" AND "Y" PORTION OF THE BAR.
- ⑨ THE "Z" DIMENSION SHALL INCREASE INCH FOR INCH WHEN THE "X" DIMENSION EXCEEDS 10".
- ⑩ LIFTING BARS SHALL BE REQUIRED TO PREVENT SPALLING OF CONCRETE AROUND HOLES.
11. WHEN THE PRECAST WALL IS USED IN PERMANENT CONSTRUCTION THE LIFTING HOLES SHALL BE FILLED WITH GROUT.

USE WITH CUR. STD. DWG.
RBM-001

KENTUCKY DEPARTMENT OF HIGHWAYS	
CONCRETE MEDIAN BARRIER PRECAST (PERMANENT - EXISTING PAVEMENT)	
STANDARD DRAWING NO. RBM-006-11	
SUBMITTED <i>[Signature]</i> DATE 02-26-20	FOR DIVISION OF DESIGN DATE
APPROVED <i>[Signature]</i> DATE 02-26-20	ENGINEER DATE