

~ NOTES ~

- ① THE MIN. LENGTH OF GUARDRAIL, INCLUDING THE END TREATMENT, PRECEDING A FIXED OBJECT IS 200 FEET (LENGTH MAY BE REDUCED SHOULD FIELD CONDITIONS WARRANT).
- ② 4'-0" OR MORE FROM NORMAL GUARDRAIL ALIGNMENT. HOWEVER, IF COLUMNS, PIERS, ABUTMENTS, ETC. ARE LOCATED IN THE CLEAR ZONE DISTANCE OR 30'-0" WHICHEVER IS GREATER FROM THE EDGE OF A THROUGH TRAVEL LANE, GUARDRAIL SHALL NOT BE REQUIRED.
- ③ TO TERMINATE GUARDRAIL INSTALLATION:
  - A. ALL FILLS, ALSO SOLID ROCK CUTS WITH ADEQUATE VEHICLE RECOVERY ZONE BEHIND GUARDRAIL; USE END TREATMENT TYPE 1 OR 4A.
  - B. SOLID ROCK CUTS WITHOUT ADEQUATE VEHICLE RECOVERY ZONE BEHIND GUARDRAIL; USE END TREATMENT TYPE 2A.
  - C. EARTH CUTS AND SOFT ROCK CUTS; USE END TREATMENT TYPE 3.
- ④ SEE CUR. STD. DWG. [RBI-007](#) OR CUR. STD. DWG. [RBI-009](#) AS APPLICABLE.
- ⑤ WHEN CONCRETE MEDIAN BARRIER WALL IS REQUIRED, SEE CUR. STD. DWG. [RBM-015](#) FOR APPLICABLE DETAILS.

LOCATION OF GUARDRAIL WITH VARIABLE WIDTH MEDIAN

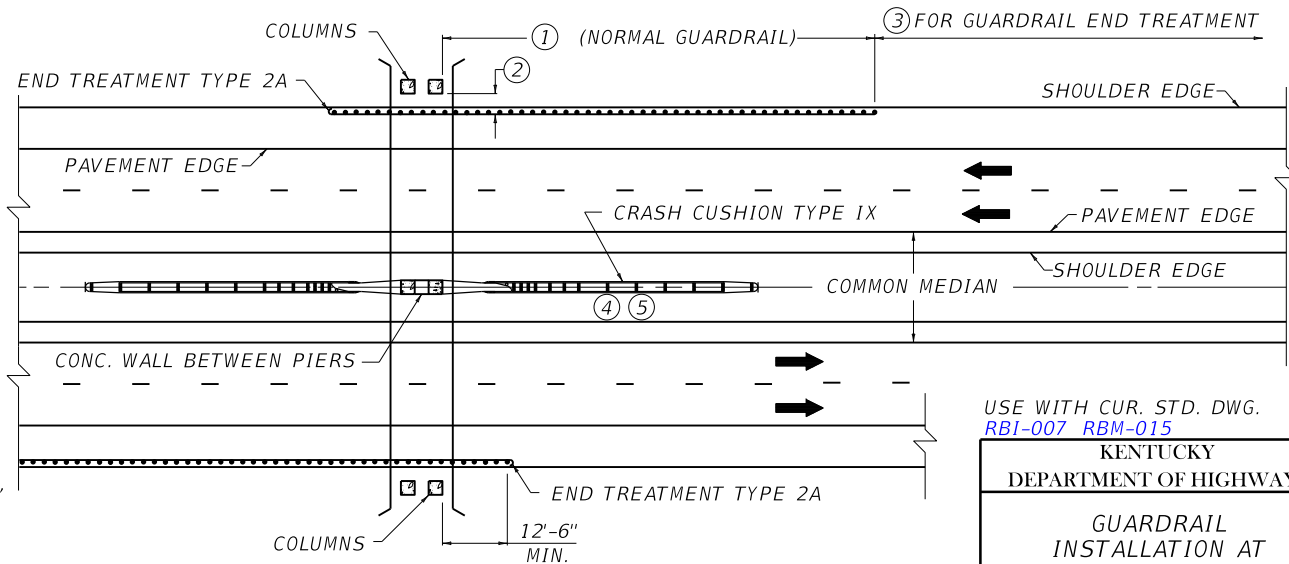

LOCATION OF GUARDRAIL WITH CONSTANT WIDTH MEDIAN

USE WITH CUR. STD. DWG.  
[RBI-007](#) [RBM-015](#)

KENTUCKY  
DEPARTMENT OF HIGHWAYS

GUARDRAIL  
INSTALLATION AT  
BRIDGE COLUMNS

STANDARD DRAWING NO. [RBI-005-08](#)

SUBMITTED  <small>DESIGNER</small>	12-01-15 <small>DATE</small>
APPROVED  <small>STATE HIGHWAY ENGINEER</small>	12-01-15 <small>DATE</small>