





CLASS	SPEED (MPH)	ATTENUATOR					SUGGESTED ADT* RANGE (P.C.P.L.) **
		MODEL	PRODUCT NAME	MANUFACTURER	WIDTH	LENGTH	
B	45 & LESS	TL3	QUADGUARD M WIDE	VALTIR OF DALLAS, TEXAS	24"	27' - 2"	UP TO 12,000
C	OVER 45	TL3	QUADGUARD ELITE M10 WIDE	VALTIR OF DALLAS, TEXAS	69"	27' - 1"	8,000 AND OVER

* AVERAGE DAILY TRAFFIC
 ** PASSENGER CARS PER LANE

~ NOTES ~

- ① NOSE ASSEMBLY (OBJECT MARKER TYPE 1 AS REQUIRED).
- ② 6" CONCRETE PAD PER MANUFACTURER SPECIFICATIONS.
- ③ WIDE WIDTH = 69".
- 4. THE CONTRACT UNIT PRICE SHALL BE CRASH CUSHION TYPE VII, CLASS  ,  .
 CLASS B OR C , AS REQUIRED.
 TEST LEVEL 2 (TL2) OR TEST LEVEL 3 (TL3), AS REQUIRED.
- ⑤ THE CONCRETE PAD, PAD EXCAVATION AND STEEL REINFORCEMENT, INSTALLED IN PLACE SHALL BE INCLUDED IN THE UNIT PRICE BID FOR CRASH CUSHION TYPE VI. DIMENSION AND REINFORCEMENT SPECIFICATIONS FOR CONCRETE PADS ARE TO BE PROVIDED BY THE MANUFACTURER. THE PAD WILL NOT BE REQUIRED WHEN THE UNIT IS CONSTRUCTED ON RIGID PAVEMENT.
- 6. THE CROSS SLOPE ON THE PAD OR PAVEMENT SHALL BE PER MANUFACTURER SPECIFICATIONS.
- 7. WHEN INSTALLED ON A STRUCTURE, DETAILS FOR ANCHORAGE SHALL BE DEVELOPED AND SHOWN ELSEWHERE ON THE PLANS.
- 8. SPECIAL WIDTH UNITS ARE AVAILABLE FROM THE MANUFACTURERS. WHEN SPECIAL WIDE UNITS ARE REQUIRED DETAILS OF THE UNIT SHALL BE DEVELOPED AND SHOWN ELSEWHERE ON THE PLANS.
- ⑨ CRASH CUSHIONS ARE TO BE INSTALLED PER MANUFACTURER SPECIFICATIONS, INCLUDING THE CONCRETE PAD. THE MANUFACTURER SHALL FURNISH TWO (2) SETS OF SHOP PLANS TO THE CONTRACTOR WITH EACH INSTALLATION.
- 10. CONCRETE PAD AND BELOW GRADE ANCHOR SHALL BE PLACED MONOLITHICALLY.
- ⑩ END SHOE MAY BE ELIMINATED WITH ONE WAY TRAFFIC.
- 12. THE CRASH CUSHION TYPE VII MAY ALSO BE UTILIZED FOR TEMPORARY USE AND CONSTRUCTION ZONES (CLASS BT).
- 13. A CRASH CUSHION TYPE VII CLASS B IS TO BE USED IN AREAS WHERE CRASH HISTORY IS NOT KNOWN TO BE SEVERE.
- 14. A CRASH CUSHION TYPE VII CLASS C IS CONSIDERED A SEVERE USE CRASH CUSHION.

ADDITIONAL BID ITEMS AND UNIT TO BID:
 OBJECT MARKER TYPE 1 (AS REQUIRED) EACH

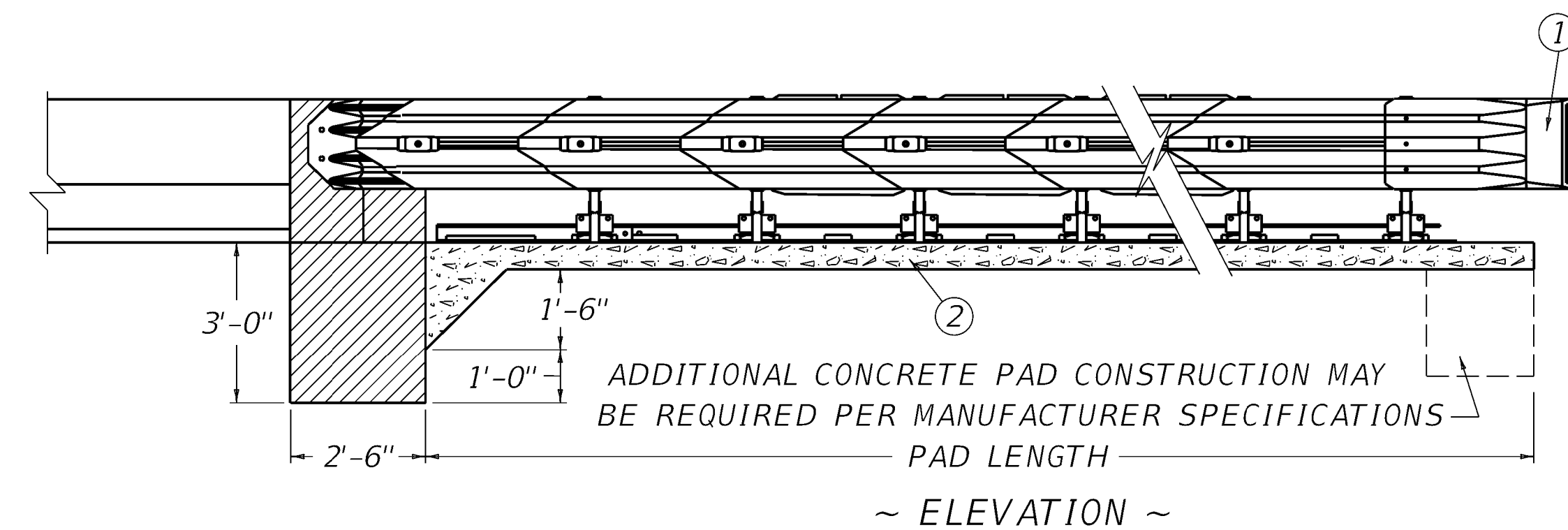
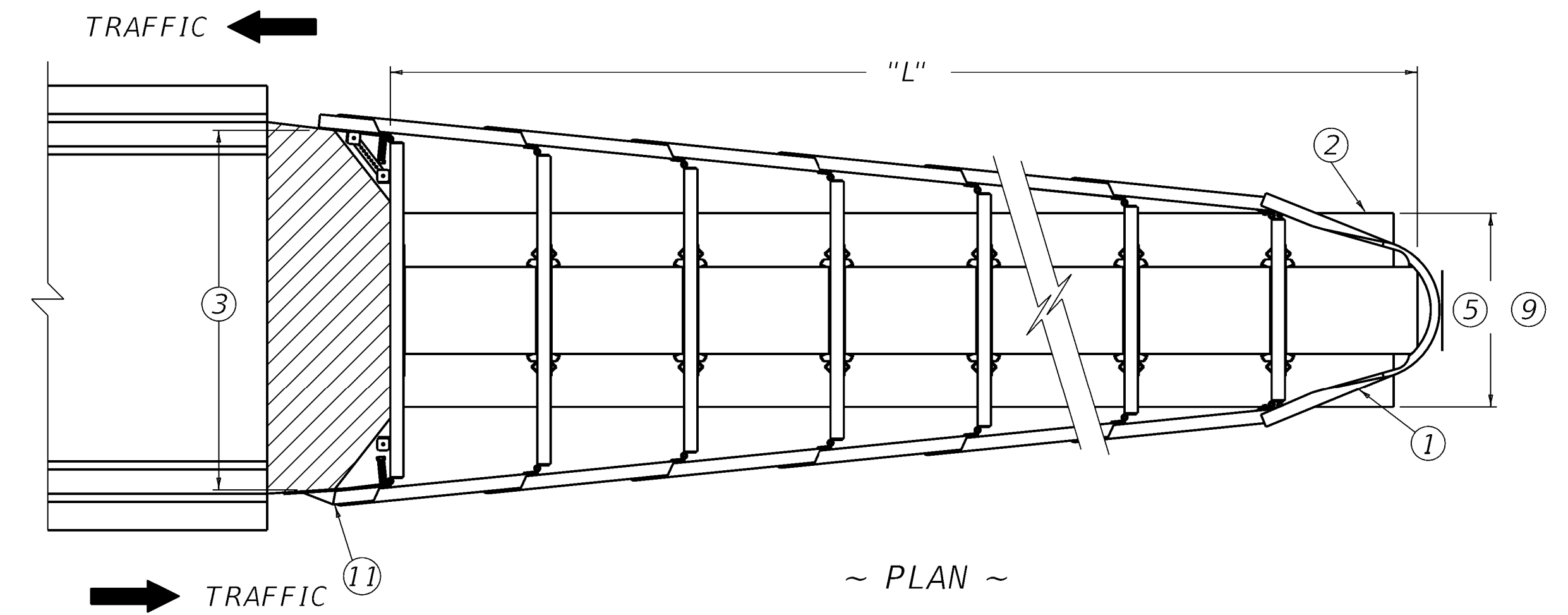

REINFORCEMENT PER MANUFACTURER SPECIFICATIONS

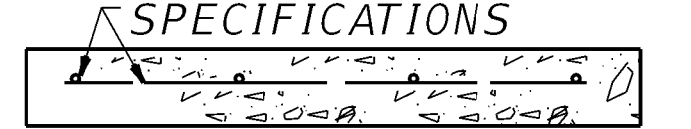

~ CONCRETE PAD SECTION ~
 (PER MANUFACTURER SPECIFICATIONS)
 REFER TO NOTES ⑤

SUBMITTED  05-03-2024
 DIVISION DIRECTOR DATE



COMMONWEALTH OF KENTUCKY
 DEPARTMENT OF HIGHWAYS

DRAWING TITLE: SEPIA 038 - CRASH CUSHION TYPE VII CLASS B AND C (ONE AND TWO DIRECTION)

ITEM NO. COUNTY OF

SHEET NO.