

**BID ITEM NOTES**

**GUARDRAIL-STEEL W BEAM (SINGLE FACE BR):** The bid unit for this item is be linear feet. This item shall include the Railing System Type II that is to be installed on the bridge between the endmost posts attached to the bridge and all labor and incidentals necessary to properly install the railing system. For non-composite box beams, the railing system is attached to the beam prior to shipment.

**GUARDRAIL-STEEL W BEAM (SINGLE FACE A):** The bid unit for this item is be linear feet. This item includes the W-Beam guardrail (2 ply for extra strength), guardrail posts, offset blocks, hardware, and labor and incidentals necessary to properly install the approach guardrail within the 25'-0" limits at each corner of the structure. For guardrail components, refer to Standard Drawings RBR-001,c.e., RBR-005,c.e. and RBR-015,c.e.

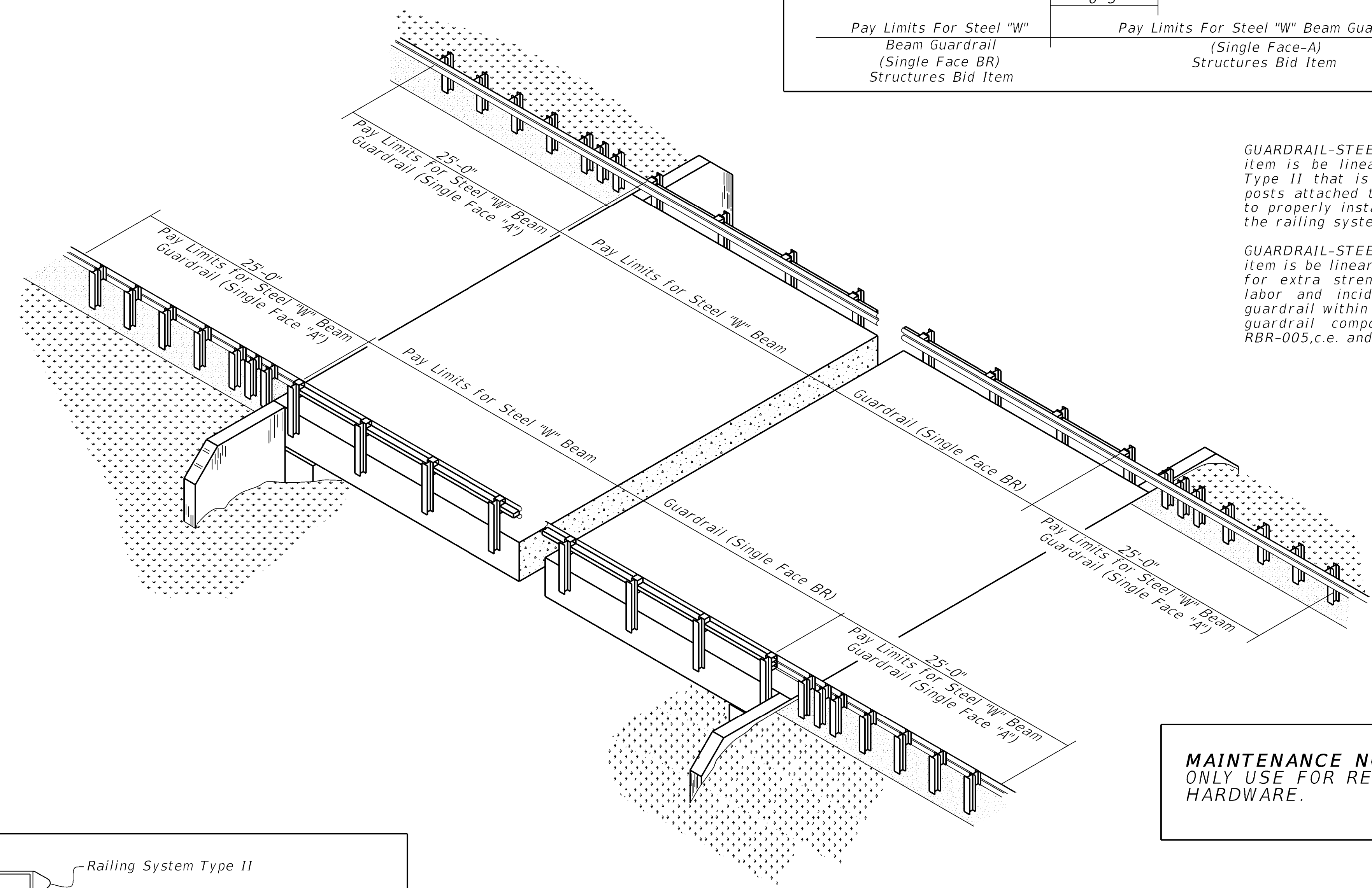

**MAINTENANCE NOTES: NOT FOR NEW CONSTRUCTION. ONLY USE FOR REPAIRING OR RESTORING EXISTING HARDWARE.**

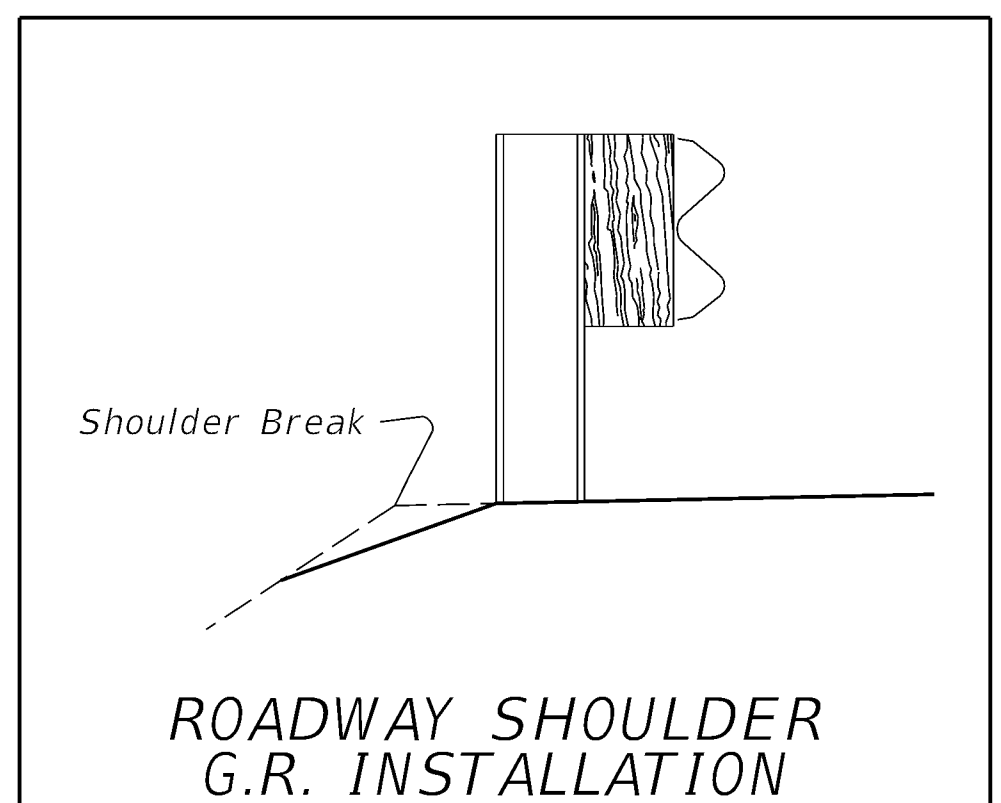
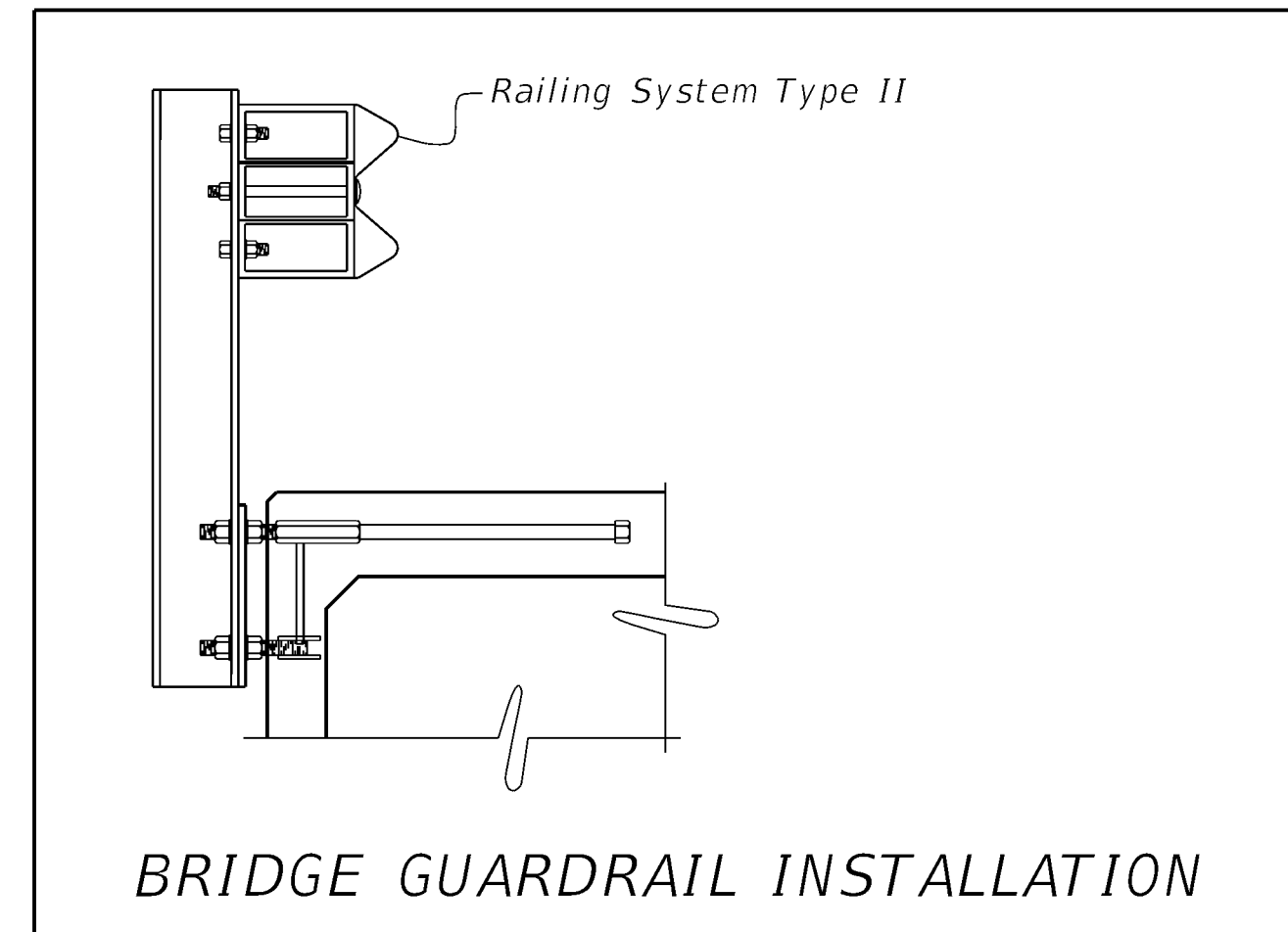

SUBMITTED  DIVISION DIRECTOR 06-23-20 DATE