

# General Notes

**SPECIFICATIONS:** All references to the Specifications are to the current edition of the Kentucky Department of Highways Standard Specifications for Road and Bridge Construction. All references to the AASHTO Specifications are to the current edition of the AASHTO LRFD Bridge Design Specifications.

**INSTALLATION PROCEDURE:** Seal the ends of the joint seal to prevent the entrance of water and foreign material.

**WELDING SPECIFICATIONS:** Ensure techniques and welding procedure comply with current joint specification ANSI/AASHTO/AWS D1.5 Bridge Welding Code.

**MATERIAL SPECIFICATIONS:** Ensure steel material is new, commercial grade steel suitable for welding. Acceptance will be based on visual inspection by the Engineer. Joint sealing material, only, is in accordance with Section 807 of the Specifications. Ensure stud shear connectors conform to ASTM A108 and A29, Grade 1015.

**LOCATION:** Locate armored edges and/or expansion dams in accordance with detail plans.

**PAINT:** Clean and paint all structural steel in accordance with the Specifications, except that no field coating will be required.

**SHOP DRAWINGS:** Contrary to the Specifications, no shop plans are required.

**BASIS OF PAYMENT:** The accepted quantities of Neoprene Expansion Dam which includes the armored edges & preformed compression joint seal will be paid for at the contract unit price per linear foot for each size, measured along centerline of joint between the vertical faces of the barriers. When only an Armored Edge is required the cost of furnishing and placing the armored edge will be paid for at the contract unit price per linear foot, measured along the Armored Edge between the vertical faces of the barriers. Measure along armored edge from fascia to fascia of slab when used with Type II railing and no curb.

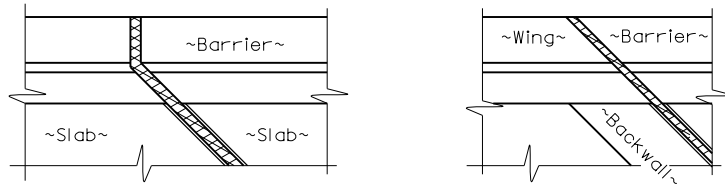

@ Piers or Bents      @ Backwall Substructures

## TYPICAL BARRIER-JOINT TREATMENTS

*Details are for skewed joints*

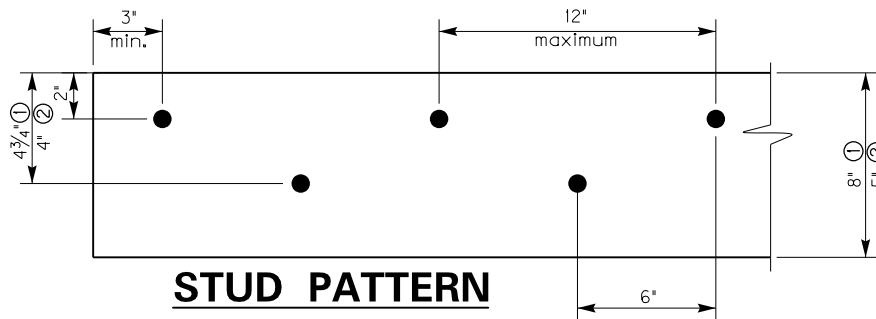

### STUD PATTERN

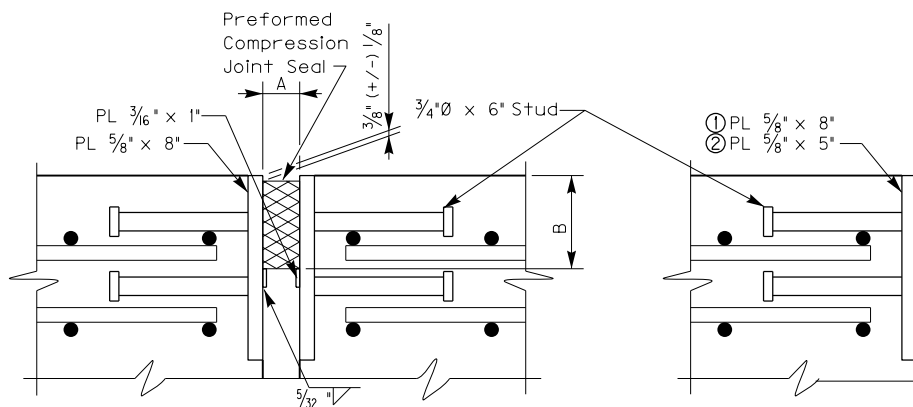

### SECTION THROUGH JOINT

"A" - Minimum Joint opening @ 60°F  
 "B" - Manufacturer's compressed seal height 1/4".

- ① Assembly weight = 18.8 lbs./ft.
- ② Assembly weight = 12.4 lbs./ft.

Joint Data		The joint seal supplied must accommodate the required movement shown. Set Dimension A with temperature change increment and as required by the manufacturer to obtain the required movement.
Dim. A @ 60°F (in)	Move-ment (in)	
1 1/2	1	
2	1 1/2	
2 1/2	2	

- ① Applies to 8" slab thickness
- ② Applies to 5" slab thickness

Temperature Change Increment per 10°F			
Concrete		Steel	
Span Length (ft)	Increment (in)	Span Length (ft)	Increment (in)
0 - 80	1/32	0 - 60	1/32
81 - 140	1/16	61 - 100	1/16
141 - 200	3/32	101 - 140	3/32
201 - 260	1/8	141 - 180	1/8
261 - 320	5/32		

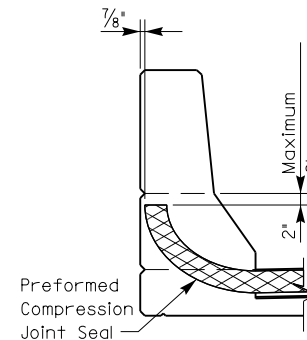

### SECTION THROUGH ARMORED EDGE

### SECTION THROUGH BARRIER

**KENTUCKY DEPARTMENT OF HIGHWAYS**

**NEOPRENE EXPANSION DAMS AND ARMORED EDGES**

STANDARD DRAWING NO. BJE-001-13

SUBMITTED *Mad. Art* DATE 12-01-15  
 DIRECTOR DIVISION OF STRUCTURAL DESIGN

APPROVED *[Signature]* DATE 12-01-15  
 STATE HIGHWAY ENGINEER