

PLAN VIEW

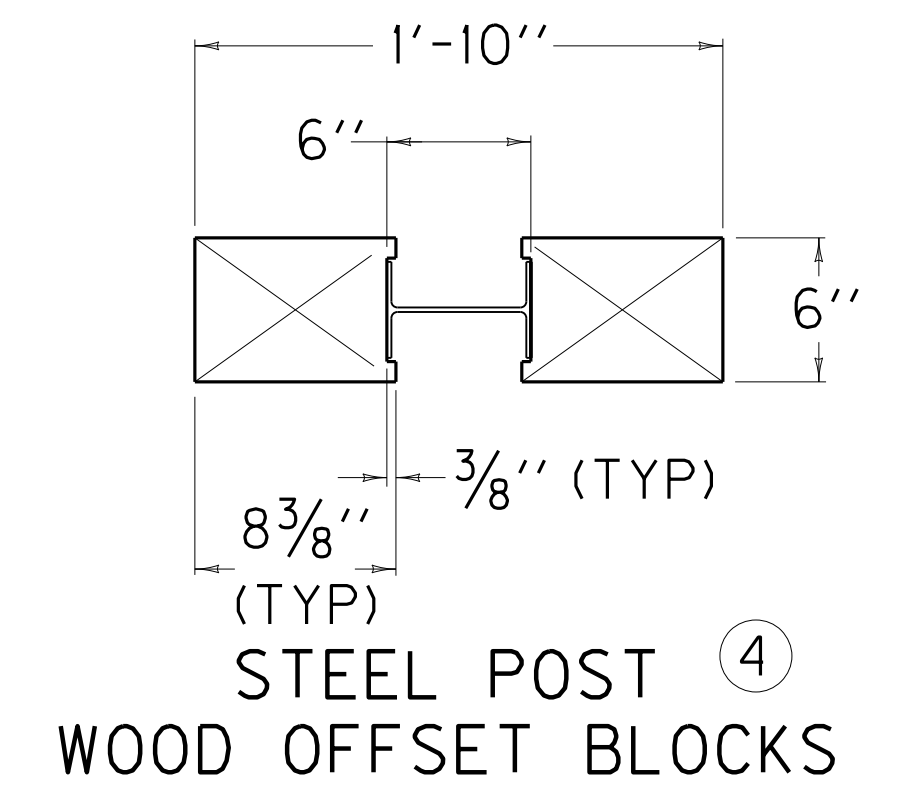
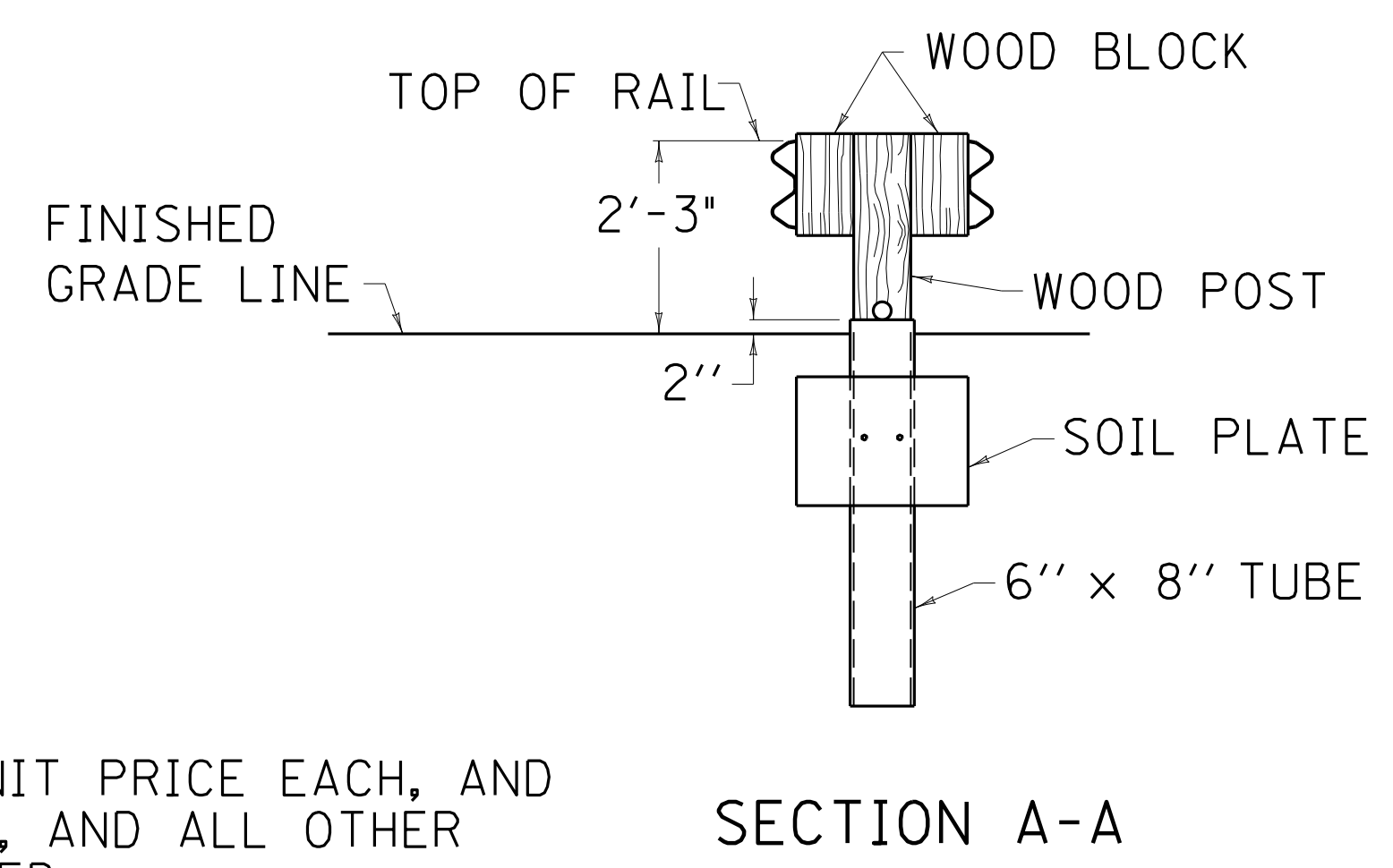
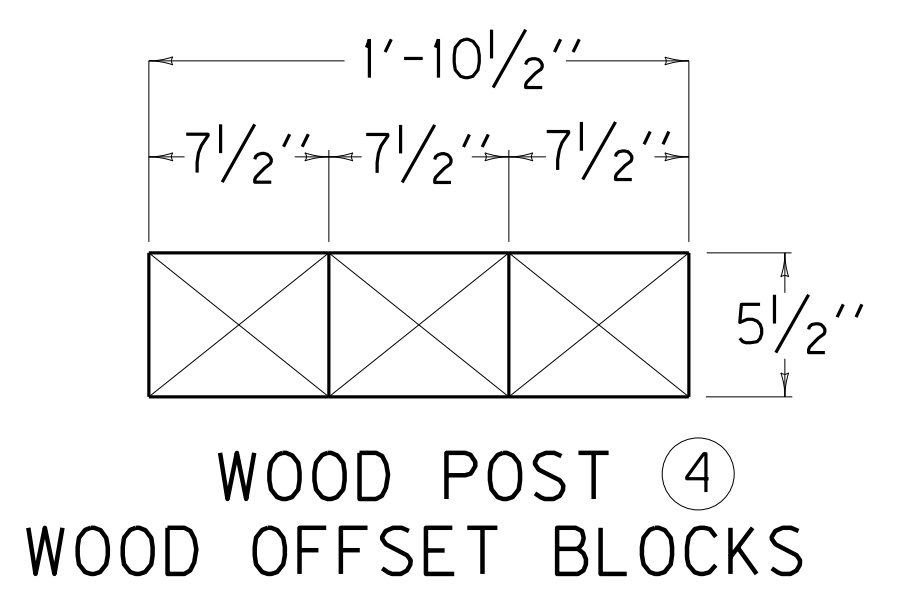

~ NOTES ~

1. CRASH CUSHION TYPE IX-A SHALL BE PAID FOR AT THE CONTRACT UNIT PRICE EACH, AND INCLUDES POSTS, RAIL ELEMENTS, OBJECT MARKER TYPE 1, HARDWARE, AND ALL OTHER INCIDENTALS NECESSARY TO COMPLETE THE INSTALLATION AS DETAILED.
 - ② OBJECT MARKER TYPE 1, (SEE CURRENT MUTCD MANUAL FOR DETAILS) CENTER HORIZ. AND VERT.
 3. CRASH CUSHION TYPE IX-A IS A PATENTED (ONE SOURCE) PRODUCT MANUFACTURED BY TRINITY INDUSTRIES, INC. OF DALLAS, TX.
 - ④ AT POST P7 AND P8 THE POSTS AND OFFSET BLOCKS MAY BE WOOD OR STEEL POST AND WOOD OFFSET BLOCKS.
 - ⑤ POST P1 THROUGH P8 ARE SPACED 6'-3" ON CENTER.
 6. BACK-UP PLATES REQUIRED AT POST P7.
 7. THE MANUFACTURER SHALL FURNISH TWO (2) SETS OF SHOP PLANS TO THE CONTRACTOR WITH EACH INSTALLATION.
 8. FOR NON-PAVEMENT APPLICATIONS SEE ROADWAY PLANS FOR GRADING DETAILS.
- BID ITEM AND UNIT TO BID
CRASH CUSHION TYPE IX-A EACH
9. NCHRP-350-COMPLIANT CRASH CUSHIONS WILL BE ACCEPTED IN INSTANCES WHERE MASH-COMPLIANT DEVICES ARE NOT YET AVAILABLE.

KENTUCKY
DEPARTMENT OF HIGHWAYS

CRASH CUSHION
TYPE IX-A

SUBMITTED:  DATE: 1-02-19
ACTING DIRECTOR DIVISION OF HIGHWAY DESIGN

023