

GRATE CONNECTED TO WALL

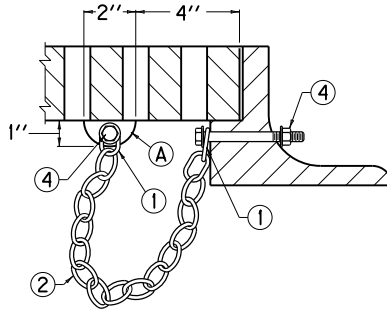

GRATE CONNECTED TO FRAME

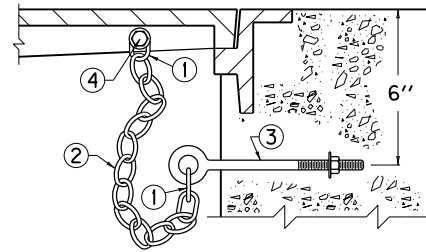

LID CONNECTED TO WALL

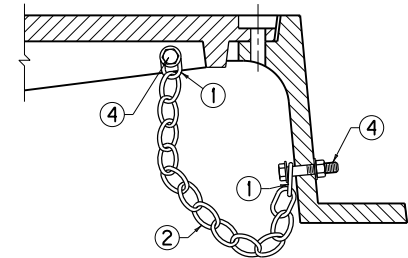

LID CONNECTED TO FRAME

TYPICAL ILLUSTRATIONS FOR CASTINGS

NOTES

- ① CHAIN SHACKLE, OR COLD SHUT OF AN APPROVED TYPE.
- ② 3/16" PROOF COIL CHAIN OF SUFFICIENT LENGTH TO ALLOW REMOVAL AND DISPLACEMENT OF GRATE OR LID.
- ③ 3/8" x 6" EYE BOLT, NUT, AND WASHER.
- ④ 3/8" HEX HEAD CAP SCREW (GRADE 2), NUT AND WASHERS. LENGTH DETERMINED BY THICKNESS OF FRAME OR GRATE. 1/16" DIA. HOLE FOR CAP SCREW. BATTER THREADS ON CAP SCREW TO PREVENT REMOVAL OF NUT.
- ⑤ 3/8" EYE BOLT (LENGTH DETERMINED BY THE FRAME DIMENSION).
6. ALL EYE BOLTS SHALL HAVE A CONTINUOUS OR SOLID EYE.
7. ALL HARDWARE SHALL BE GALVANIZED AND OF COMMERCIAL QUALITY AND SHALL BE APPROVED BY THE ENGINEER.
8. THE COST OF THE COMPLETE SECURITY DEVICE, INSTALLED, SHALL BE INCIDENTAL TO THE COST OF THE STRUCTURE.
9. THE DESIGNS SHOWN ARE ACCEPTABLE; HOWEVER ARE SUBJECT TO CHANGE IF APPROVED IN WRITING BY THE ENGINEER.

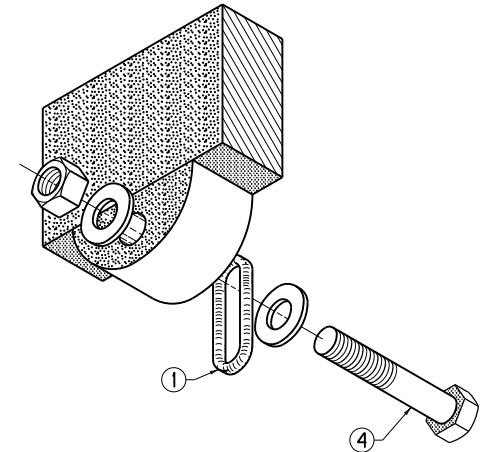

① LUG ON CENTER CROSS MEMBER AND BOLT ASSEMBLY (AXONOMETRIC VIEW)

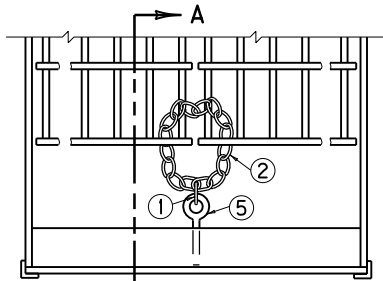

PLAN VIEW

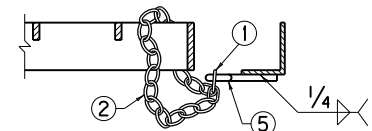

SECTION A-A

GRATE CONNECTED TO FRAME

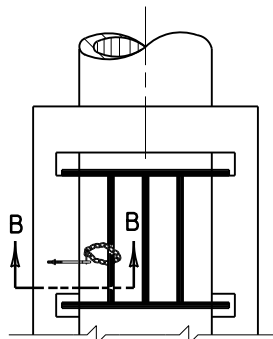

PLAN VIEW

GRATE CONNECTED TO WALL

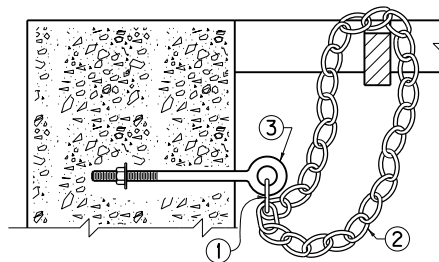

SECTION B-B

TYPICAL ILLUSTRATIONS FOR STRUCTURAL STEEL UNITS

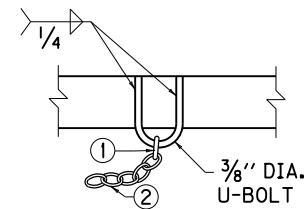

ALTERNATE FOR STRUCTURAL STEEL MEMBERS

KENTUCKY DEPARTMENT OF HIGHWAYS		
SECURITY DEVICES FOR FRAMES, GRATES AND LIDS		
STANDARD DRAWING NO. RDX-160-05		
SUBMITTED <i>John B. Sackett</i>	12-1-99	DATE
DIRECTOR, DIVISION OF DESIGN		
APPROVED <i>J. M. Yourell</i>	12-1-99	DATE
STATE HIGHWAY ENGINEER		