

SIDE ELEVATION

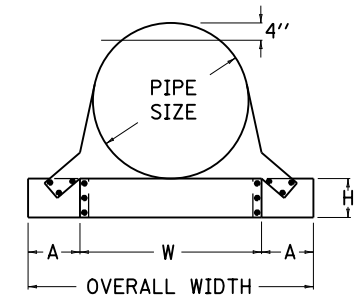

END SECT. FRONT VIEW CIRCULAR PIPE

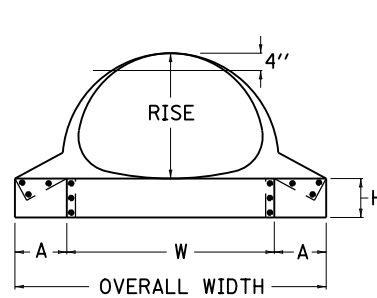

END SECT. FRONT VIEW ARCHED PIPE

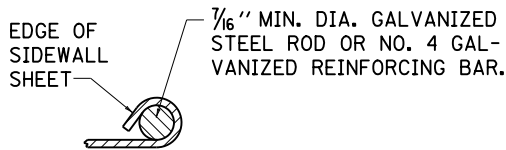

SECTION A-A

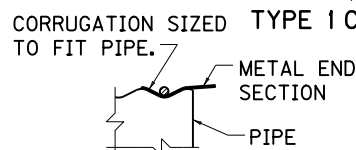

SECTION B-B



TYPE 1 CONNECTOR

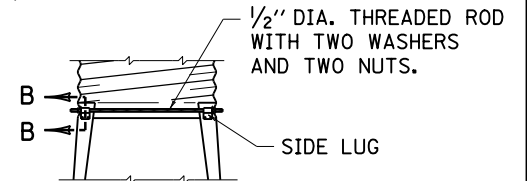

TYPE 2 CONNECTOR

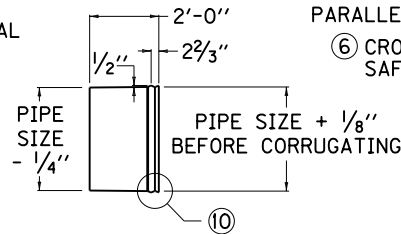

SMOOTH TAPERED SLEEVE FOR USE WITH CONCRETE PIPE

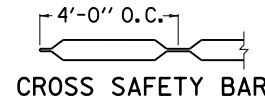

CROSS SAFETY BAR

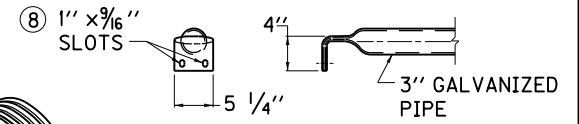

PARALLEL SAFETY BAR

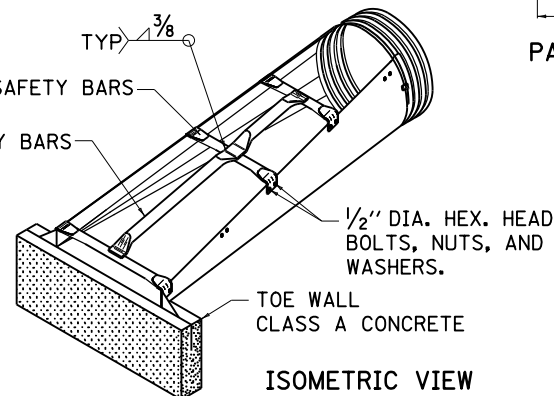

ISOMETRIC VIEW

NOTES

- BID ITEM:
METAL END SECT. TY. \otimes - \triangle INCH
 \otimes 3 = CROSSDRAIN STRUCTURE ON 4:1 SLOPE, 4 = CROSSDRAIN STRUCTURE ON 6:1 SLOPE
 \triangle SIZE IN INCHES
 BID ITEM EXAMPLE: METAL END SECT. TY. 3 - 15 INCH.
- THE CONTRACT UNIT PRICE EACH FOR METAL END SECTION SHALL INCLUDE CLASS A CONCRETE, EXCAVATION, AND ALL INCIDENTALS NECESSARY TO COMPLETE ONE INSTALLATION AS DETAILED.
- FABRICATE METAL END SECTIONS FROM GALVANIZED SHEETS CONFORMING TO AASHTO M218.
 - METAL END SECTIONS & TAPERED SLEEVES SHALL BE ASPHALT COATED IN ACCORDANCE WITH SECT. 806 OF THE CUR. KENTUCKY STD. SPECIFICATIONS FOR ROAD & BRIDGE CONSTRUCTION. ASPHALT COATING IS NOT REQUIRED ON SAFETY BARS.
 - SAFETY BARS SHALL BE REQUIRED ON ALL 30" ROUND PIPE AND LARGER.
 - SAFETY BARS SHALL BE REQUIRED ON ALL 24" ELLIPTICAL EQUIVALENT PIPE AND LARGER.
 - SAFETY BARS SHALL BE CONSTRUCTED OF SCHEDULE 40 GALVANIZED STEEL PIPE (COML. GRADE).
 - \otimes CROSS SAFETY BARS SHALL BE SPACED A MAXIMUM OF 30" O.C. AND WELDED TO PARALLEL SAFETY BARS. GALVANIZING REQUIRED AFTER FABRICATION.
 - THE TAPERED SLEEVE SHALL BE GALVANIZED SMOOTH METAL CONFORMING TO AASHTO M218, WITH A WALL THICKNESS AS FOLLOWS: 18" DIA. OR LESS = .079", 21" DIA. OR LARGER = .109".
 - \otimes SLOTTED HOLES FOR SAFETY BAR ATTACHMENT SHALL BE PUNCHED PRIOR TO GALVANIZING. FIELD DRILLING OF HOLES SHALL NOT BE PERMITTED.
 - WATERPROOF MASTIC CONFORMING TO 807.02.03 OF THE STD. SPECS. SHALL BE PLACED IN THE VOID BETWEEN THE TAPERED SLEEVE AND CONCRETE PIPE.
 - FORM $1/2" \times 2 2/3"$ CORRUGATIONS. MAINTAIN INSIDE DIAMETER OF SLEEVE. FINISHED END TO BE THE SAME DIAMETER AS CORRUGATED STEEL PIPE DIAMETER.
 - ALL MISCELLANEOUS HARDWARE SHALL COMPLY WITH AASHTO M36.
 - THE WELDS USED IN THE MANUFACTURE OF THE TAPERED SLEEVE FOR ELLIPTICAL CONCRETE PIPE SHALL BE REPAIRED IN ACCORDANCE WITH AASHTO M36 USING ZINC OXIDE-ZINC DUST PRIMER, FEDERAL SPECIFICATION TT-P-641, TYPE II, NO COLOR ADDED.

USE WITH CUR. STD. DWG. RDB-160		
KENTUCKY DEPARTMENT OF HIGHWAYS		
METAL END SECTION TYPE 3 AND 4 (CROSS STRUCTURES)		
STANDARD DRAWING NO. RDB-155-01		
SUBMITTED	<i>John B. Sackett</i> DIRECTOR DIVISION OF DESIGN	12-1-99 DATE
APPROVED	<i>J. M. Powell</i> STATE HIGHWAY ENGINEER	12-1-99 DATE