

BOX INLET - OUTLET SIZE	GRATE		BAR NO. 1	BAR NO. 2	BARS NO. 3		BARS NO. 4		LBS. STRUCTURAL STEEL	
	NO.	SIZE	LENGTH	LENGTH	NO. BARS	LENGTH	LENGTH	EACH GRATE	TOTAL	
18"	1	2'-0"	2'-6 $\frac{1}{2}$ "	3'-5 $\frac{3}{4}$ "	4	1'-10"	1'-10 $\frac{1}{4}$ "	116	272	
	2	2'-0"	3'-7 $\frac{5}{8}$ "	4'-6 $\frac{7}{8}$ "	6	1'-10"	1'-10 $\frac{1}{4}$ "	156		
24"	1	3'-0"	3'-1 $\frac{1}{2}$ "	4'-6 $\frac{5}{8}$ "	5	2'-10"	2'-10 $\frac{3}{8}$ "	187	454	
	2	3'-0"	4'-8 $\frac{1}{2}$ "	6'-1 $\frac{5}{8}$ "	8	2'-10"	2'-10 $\frac{3}{8}$ "	267		
30"	1	3'-0"	3'-8 $\frac{1}{2}$ "	5'-1 $\frac{1}{2}$ "	6	2'-10"	2'-10 $\frac{3}{8}$ "	215	796	
	2	3'-0"	5'-3 $\frac{1}{2}$ "	6'-8 $\frac{5}{8}$ "	9	2'-10"	2'-10 $\frac{3}{8}$ "	294		
	3	2'-0"	6'-10 $\frac{1}{2}$ "	7'-9 $\frac{3}{4}$ "	13	1'-10"	1'-10 $\frac{1}{4}$ "	287		
36"	1	3'-0"	4'-3 $\frac{1}{2}$ "	5'-8 $\frac{1}{2}$ "	7	2'-10"	2'-10 $\frac{3}{8}$ "	242	1218	
	2	3'-0"	5'-10 $\frac{1}{2}$ "	7'-3 $\frac{5}{8}$ "	10	2'-10"	2'-10 $\frac{3}{8}$ "	321		
	3	2'-0"	7'-5 $\frac{1}{2}$ "	8'-4 $\frac{3}{4}$ "	14	1'-10"	1'-10 $\frac{1}{4}$ "	308		
	4	2'-0"	8'-6 $\frac{3}{4}$ "	9'-5 $\frac{1}{8}$ "	16	1'-10"	1'-10 $\frac{1}{4}$ "	347		

~ NOTES ~

- ALL COMPONENTS ARE 1" X 2" STRUCTURAL STEEL BARS.
- Ⓐ EQUALLY SPACE BARS NO. 3.
- Ⓑ SIZE OF GRATE EITHER 2'-0" OR 3'-0".
- Ⓒ 5 $\frac{1}{2}$ " FOR 2'-0" GRATE, 7" FOR 3'-0" GRATE.

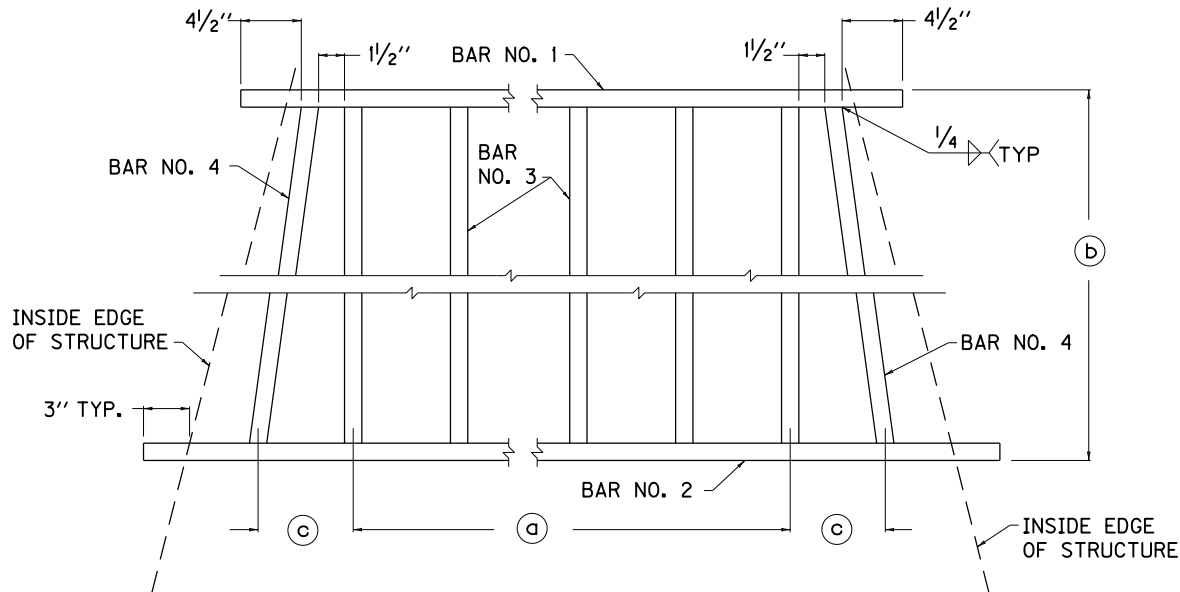

TYPICAL GRATE

USE WITH CUR. STD. DWG.  
RDB-105

KENTUCKY  
DEPARTMENT OF HIGHWAYS

GRATES FOR  
SLOPED AND FLARED  
BOX INLET - OUTLET

STANDARD DRAWING NO. RDB-106-04

SUBMITTED: *John B. Sackett* 12-1-99  
DIRECTOR, DIVISION OF DESIGN DATE  
APPROVED: *J. M. Powell* 12-1-99  
STATE HIGHWAY ENGINEER DATE