

NOTES

TRANSITION CONDITION NO. 1, 2 AND 3 ALONG WITH SYMMETRICAL AND ASYMMETRICAL BARRIER SECTIONS ARE DEPICTED ON THIS DRAWING FOR ILLUSTRATION PURPOSES ONLY AT STRUCTURES AND FIXED OBJECTS. (SEE PLANS FOR ADDITIONAL DETAILS)

ALL PAVEMENT, FILL MATERIAL, PIPE DRAINAGE (EXCLUSIVE OF WEEP HOLE PIPE) PLACED BETWEEN SEGMENTS OF THE BARRIER SHALL BE SHOWN SEPARATELY OR INCLUDED WITH OTHER LIKE PAY ITEMS ON THE PROJECT.

FOR APPLICATION DETAILS TO NEW OR EXISTING PAVEMENT SEE DRAWING ENTITLED "CONCRETE MEDIAN BARRIER, FIXED FORM OR SLIP FORM (PERMANENT)".

THE METHOD OF MEASUREMENT FOR CONCRETE MEDIAN BARRIER FOR EACH TYPE WILL BE IN LINEAR FEET MEASURED ALONG THE TOP CENTERLINE OF THE BARRIER.

THE SEPARATE OR SOLID BARRIER SHALL BE SHOWN IN THE BID ITEM AS FOLLOWS: "CONCRETE MEDIAN BARRIER ⊕ ⊕ ☆"

⊕ 9, 12, OR 14 DEPENDING ON "W"

⊕ A, B, C, D OR E DEPENDING ON PAVEMENT APPLICATION.

☆ 1 = SOLID SEGMENT- DENOTES BARRIER WALL WITH:

a. TRANSITION FROM "W" WIDTH TO MAX. WIDTH OF 4'.

b. CONSTANT WIDTH WALL GREATER THAN "W" WIDE BUT NOT GREATER THAN 4' WIDE. (EX.: WALL BETWEEN BRDG. PIERS).

2 = SEPARATE SEGMENT

③ SEE ELSEWHERE IN PLANS FOR SIZE, LOCATION AND PAYMENT FOR RACEWAY WHEN REQUIRED.

④ 4" PIPE FOR WEEP HOLES SPACED ON 20' CENTERS AND STAGGERED 10' WITH EACH WALL.

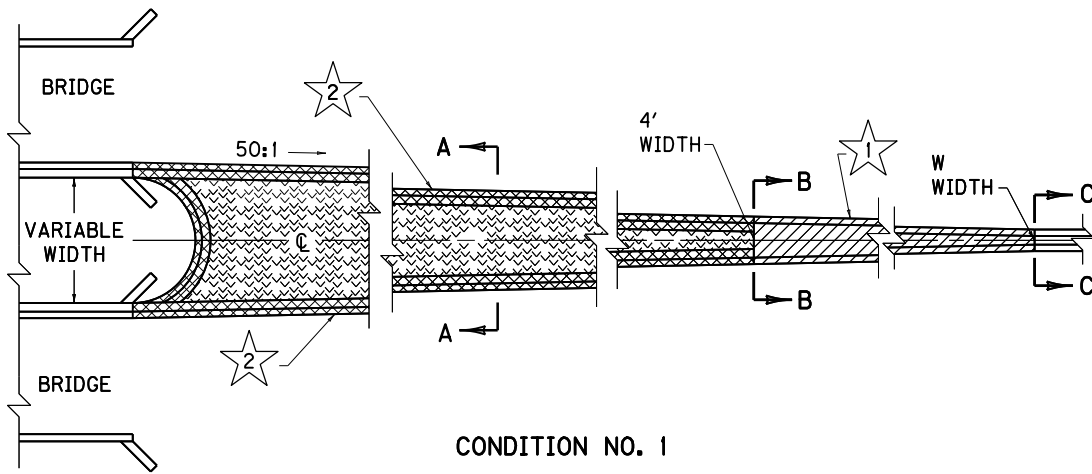

CONDITION NO. 1

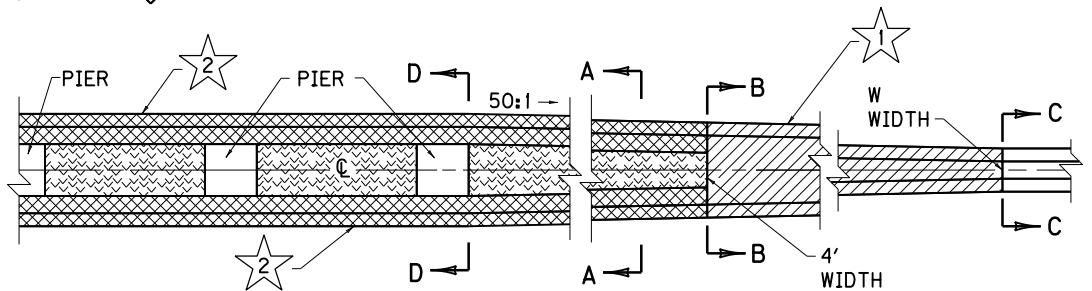

CONDITION NO. 2

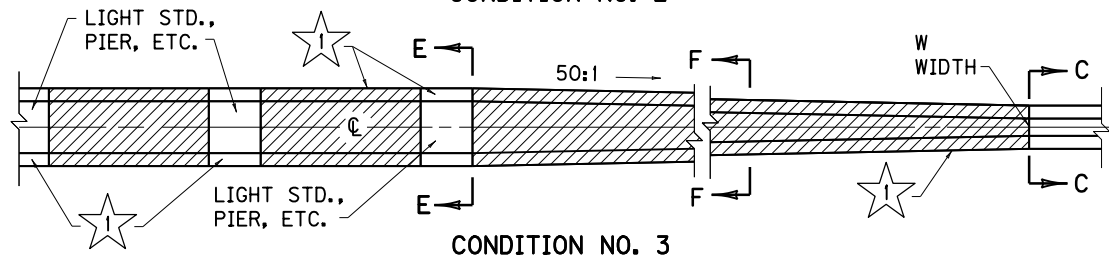

CONDITION NO. 3

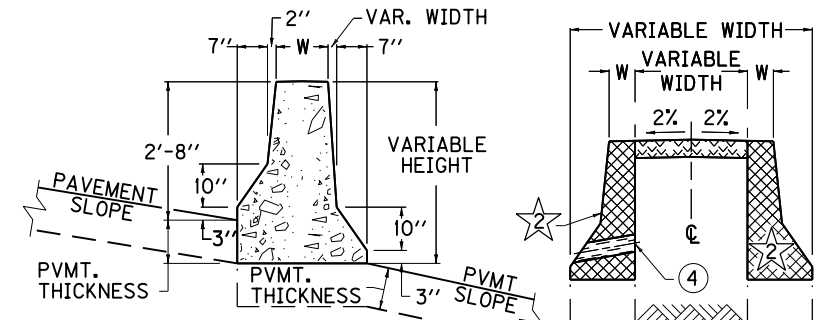

ASYMMETRICAL WALL SECTION

SECTION A-A

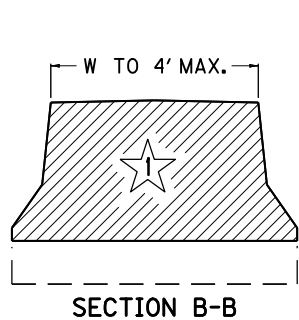

SECTION B-B

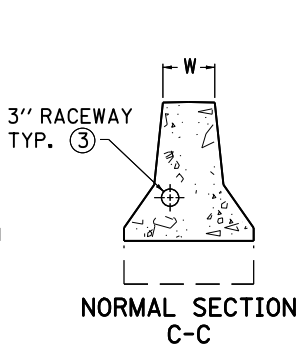

NORMAL SECTION C-C

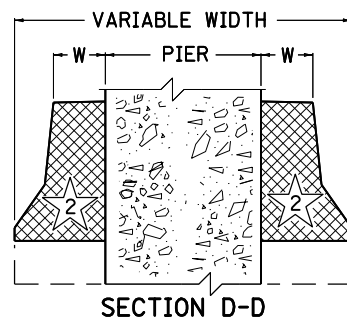

SECTION D-D

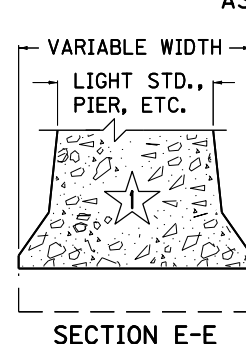

SECTION E-E

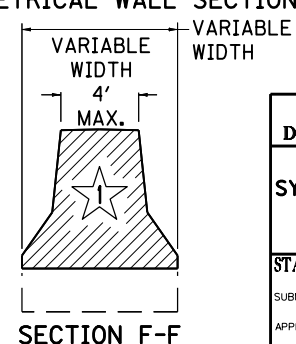

SECTION F-F

KENTUCKY	
DEPARTMENT OF HIGHWAYS	
CONCRETE MEDIAN BARRIER	
SYMMETRICAL & ASYMMETRICAL	
SEPARATE & TRANSITION	
DETAILS	
STANDARD DRAWING NO. RBM-015-05	
SUBMITTED: <i>Tom W. Stone</i>	12-2-02
DIRECTOR DIVISION OF DESIGN	DATE
APPROVED: <i>J. M. Howell</i>	12-2-02
STATE HIGHWAY ENGINEER	DATE