

PEDESTRIAN PATH
STA 0+19.73 STA 2+41.09

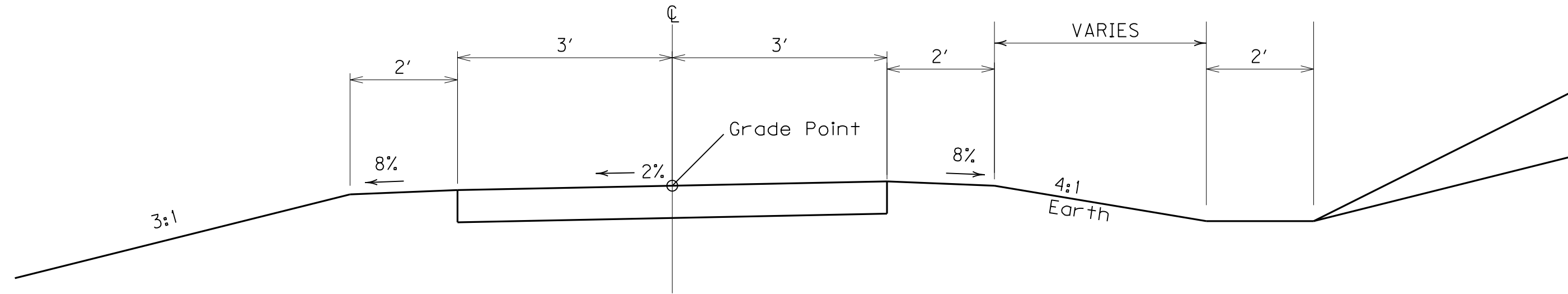

PEDESTRIAN PATH
STA 4+08.09 TO STA 6+11.94

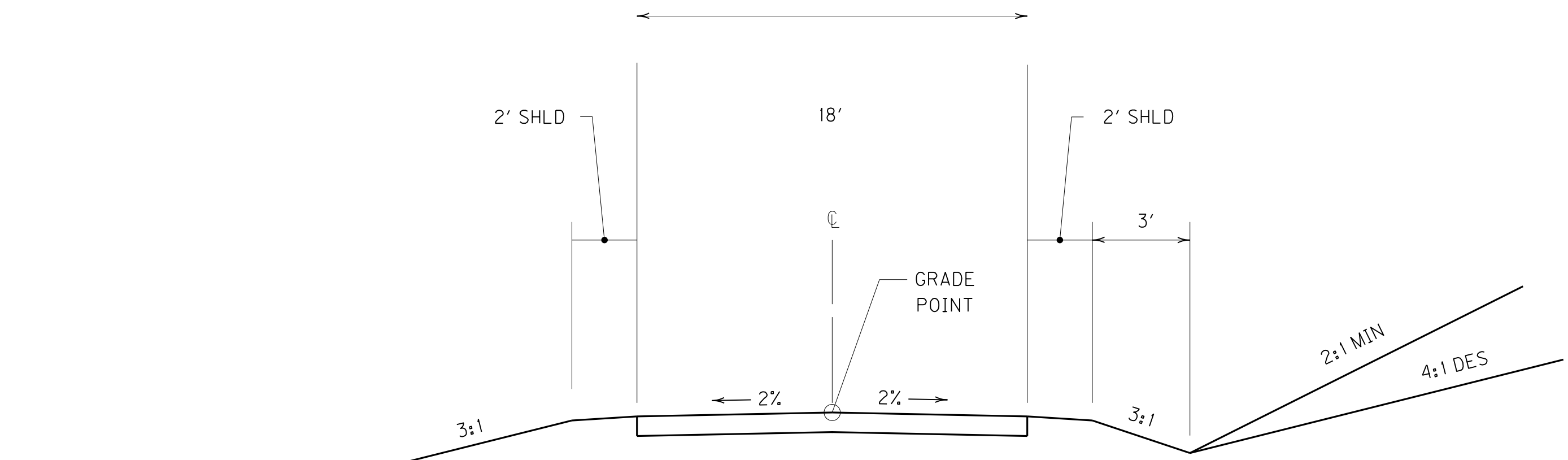

MILL STREET