



CALL NO. 411

CONTRACT ID. 102174

CAMPBELL COUNTY

FED/STATE PROJECT NUMBER 019GR10P053-FD05

DESCRIPTION KY 547 AND KY 1120 IN CAMPBELL COUNTY

WORK TYPE ASPHALT RESURFACING

PRIMARY COMPLETION DATE 11/15/2010

LETTING DATE: May 28, 2010

Sealed Bids will be received in the Division of Construction Procurement and/or the 1st floor of the Transportation Cabinet Office Building until 10:00 AM EASTERN DAYLIGHT TIME May 28, 2010. Bids will be publicly opened and read at 10:00 AM EASTERN DAYLIGHT TIME.

DEFERRED PAYMENT

REQUIRED BID PROPOSAL GUARANTY: Not less than 5% of the total bid.

(Check guaranty submitted: Cashier's Check Certified Check Bid Bond)

BID BONDS WHEN SUBMITTED WILL BE RETAINED WITH THE PROPOSAL

DBE General Plan Included

BID

PROPOSAL ISSUED TO: _____

SPECIMEN

Address City State Zip

TABLE OF CONTENTS

PART I	SCOPE OF WORK
	<ul style="list-style-type: none">• PROJECT(S), COMPLETION DATE(S), & LIQUIDATED DAMAGES• CONTRACT NOTES• 2010 DEFERRED PAYMENT• SURFACING AREAS• ASPHALT MIXTURE• INCIDENTAL SURFACING• FUEL AND ASPHALT PAY ADJUSTMENT• OPTION B• WASTE AND BORROWED SITES• AWARD OF CONTRACT• MANHOLE ADJUSTMENTS• SHOULDERING BY STATE FORCES• EDGE KEY• ASPHALT MILLING AND TEXTURING• BASE FAILURE REPAIR• TYPICAL SECTION DIMENSIONS• SIDEWALK RAMPS & DETECTABLE WARNINGS• TRAFFIC CONTROL PLAN• TRAFFIC SIGNAL LOOP DETECTORS• SKETCH MAP(S)• MATERIAL SUMMARY• SUMMARY SHEET(S)• TYPICAL SECTION(S)
PART II	SPECIFICATIONS AND STANDARD DRAWINGS
	<ul style="list-style-type: none">• SPECIFICATIONS REFERENCE• SUPPLEMENTAL SPECIFICATIONS• STANDARD DRAWINGS THAT APPLY• CONCRETE ENTRANCE PAVEMENT AND SIDEWALK• SIDEWALK RAMPS• DETECTABLE WARNINGS
PART III	EMPLOYMENT, WAGE AND RECORD REQUIREMENTS
	<ul style="list-style-type: none">• LABOR AND WAGE REQUIREMENTS• EXECUTIVE BRANCH CODE OF ETHICS• KENTUCKY EQUAL EMPLOYMENT OPPORTUNITY ACT OF 1978• PROJECT WAGE RATES
PART IV	INSURANCE
PART V	BID ITEMS

PART I
SCOPE OF WORK

CONTRACT ID - 102174

ADMINISTRATIVE DISTRICT - 06

PROJECT(S) IDENTIFICATION AND DESCRIPTION:

COUNTY - CAMPBELL
019GR10P053-FD05

KY 547 AND KY 1120 IN CAMPBELL COUNTY

COUNTY - CAMPBELL
FD05 019 0547 000-004

PES - MP01905471001

RILEY ROAD-FOUR MILE ROAD (KY 547) FROM KY 10 (MP 0.000) EXTENDING NORTH TO NINE MILE ROAD (MP 3.585), A DISTANCE OF 3.59 MILES. ASPHALT RESURFACING.

GEOGRAPHIC COORDINATES LATITUDE 38^59'34" LONGITUDE 84^21'46"

AVERAGE DAILY TRAFFIC - 2920 AVERAGE MAINLINE WIDTH - 21.0 FEET

COUNTY - CAMPBELL
FD05 019 1120 000-001

PES - MP01911201001

WEST 11TH STREET (KY 1120) FROM SHORTWAY BRIDGE PCC APPROACH PAVEMENT AT BRIGHTON ST. (MP 0.228) EXTENDING EAST TO YORK STREET (MP 0.668), A DISTANCE OF 0.44 MILES. ASPHALT RESURFACING.

GEOGRAPHIC COORDINATES LATITUDE 39^05'00" LONGITUDE 84^29'32"

AVERAGE DAILY TRAFFIC - 7320 AVERAGE MAINLINE WIDTH - 40.0 FEET

COMPLETION DATE(S):

COMPLETION DATE - November 15, 2010

APPLIES TO ENTIRE CONTRACT

CONTRACT NOTES

PROPOSAL ADDENDA

All addenda to this proposal must be applied when calculating bid and certified in the bid packet submitted to the Kentucky Department of Highways. Failure to use the correct and most recent addenda may result in the bid being rejected.

BID SUBMITTAL

Bidder must use the Department's Expedite Bidding Program available on the Internet web site of the Department of Highways, Division of Construction Procurement. (www.transportation.ky.gov/contract)

The Bidder must download the bid file located on the web site to prepare a bid packet for submission to the Department. The bidder must include the completed bid packet printed from the Program along with the disk created by said program or submit electronically using Bid Express.

JOINT VENTURE BIDDING

Joint Venture bidding is permissible. However, both companies MUST purchase a bidding proposal. Either proposal may be submitted but must contain the company names and signatures of both parties where required. A joint bid bond of 5% may be submitted for both companies or each company may submit a separate bond of 5%.

UNDERGROUND FACILITY DAMAGE PROTECTION

The contractor is advised that the Underground Facility Damage Protection Act of 1994, became law January 1, 1995. It is the contractor's responsibility to determine the impact of the act regarding this project, and take all steps necessary to be in compliance with the provision of the act.

01/01/2009

DEFERRED PAYMENT: The successful bidder on this project may request a work order with an effective date prior to June 15, 2010. The request must be in writing to the Department. A work order issued at the request of the Contractor will be with the distinct understanding that payment for any work performed estimates may be delayed until July 15, 2010. A work order will be issued June 15, 2010, for this project unless the bidder requests an earlier work date.

SURFACING AREAS (KY 1120)

Mainline surfacing width is estimated to be 40 feet.

Total mainline area to be surfaced is estimated to be 11,355 square yards.

Curb & gutter typical section, there are no shoulders.

SURFACING AREAS (KY 547)

Mainline surfacing width is estimated to vary 21-36 feet.

Total mainline area to be surfaced is estimated to be 51,400 square yards.

There are no paved shoulders; the Department will perform earth shouldering.

ASPHALT MIXTURE

The rate of application for all asphalt mixtures shall be estimated at 110 lbs/sy per inch of depth, unless otherwise noted.

INCIDENTAL SURFACING

The quantities established in the proposal include estimated quantities required for resurfacing or surfacing mailbox turnouts, farm field entrances, residential and commercial entrances, and road and street approaches. These items are to be paved to the limits as shown on Standard Drawing RPM 110 or to the limits as directed by the Engineer. In the event signal detectors are present in the intersecting streets or roads, the paving of the crossroads shall be to the right of way limit or back of the signal detector, whichever is the farthest back of the mainline. These areas are to be surfaced or resurfaced as directed by the Engineer and no direct payment will be allowed for placing and compacting.

FUEL AND ASPHALT PAY ADJUSTMENT

The following contract items: Asphalt Adjustment and Fuel Adjustment, are for possible future payments. Additional monies may need to be setup with an additional change order if existing contract amount is insufficient to pay all items on the contract. Unit price is \$1.00. Quantity will be actual adjustment after work is completed.

OPTION B

The Contractor is advised that the compaction of asphalt mixtures furnished to KY 1120 and KY 547 will be accepted by OPTION B in accordance with Section 402 and Section 403 of the current Standard Specification.

SPECIAL PROVISION FOR WASTE AND BORROW SITES

The contractor is advised that it is their responsibility to gain U.S. Army Corp of Engineer's approval before utilizing a waste or borrow site that involves "Waters of the United States". "Waters of the United States" are defined as perennial or intermittent streams, ponds or wetlands. Ephemeral streams are also considered jurisdictional waters, and are typically dry except during rainfall, but have a defined drainage channel. Questions concerning any potential impacts to "Waters..." should be brought to the attention of the appropriate District Office for the Corps of Engineers for a determination, prior to disturbance. Any fees associated with obtaining approval from the U.S. Army Corp of Engineer or other appropriate regulatory agencies for waste and borrow sites is the responsibility of the contractor.

01/01/2009

SPECIAL NOTE FOR AWARD OF CONTRACT

Contrary to Section 103.02, the Department may hold the Bid Proposals of any or all bidders for a period not to exceed 90 calendar days for final disposition of award. The Department may hold the Bid Proposal of the lowest bidder longer than 90 calendar days if the bidder concurs.

Contrary to Section 103.04, The Department will hold the Proposal Guaranty of the lowest bidder and the Proposal Guaranty of the second lowest bidder, as determined by the Commissioner, until the Department awards the Contract and executes and approves the Contract and bond of the successful bidder, or until the Department rejects all Bid Proposals. If the Department does not make an award within 90 calendar days, the Department will return all Proposal Guaranties.

Except as provided in this note or elsewhere in the proposal, all other applicable portions of Section 103 apply.

01/01/2009

**SPECIAL NOTE FOR MANHOLE ADJUSTMENTS
KY 1120 & KY 547**

Manhole adjustments are the responsibility of the City of Newport, City of Alexandria, Northern Kentucky Sanitation District No. 1, Cincinnati Bell, and/or Cincinnati Gas & Electric Co., as applicable. Notify the Engineer a minimum of 30 calendar days prior to beginning any work on the project. Unless directed otherwise by the Engineer, do not begin resurfacing until the manhole adjustments are completed by the owners. The Engineer will coordinate the work between the Contractor and City.

**SPECIAL NOTE FOR SHOULDERING BY STATE FORCES
KY 547**

The Department will complete earth shoulders which will include regrading, reshaping, adding, and compacting of suitable materials on the existing shoulders to provide proper template or foundation.

Notify the Engineer a minimum of two (2) weeks in writing prior to beginning any work on the project. The Engineer will coordinate the shoulder work between the Contractor and State Forces.

SPECIAL NOTE FOR EDGE KEY KY 547

Construct Edge Keys at the beginning of project, end of project, at railroad crossings, and at ramps, as applicable. Cut out the existing asphalt surface to the required depth and width shown on the drawing. Heel new surface into the existing surface. The Department will pay for this work at the contract unit price per ton for "Asphalt Pavement Milling and Texturing", which shall be full compensation for all labor, materials, equipment, and incidentals for removal and disposal of the existing asphalt surface required to construct the edge key.

EDGE KEY

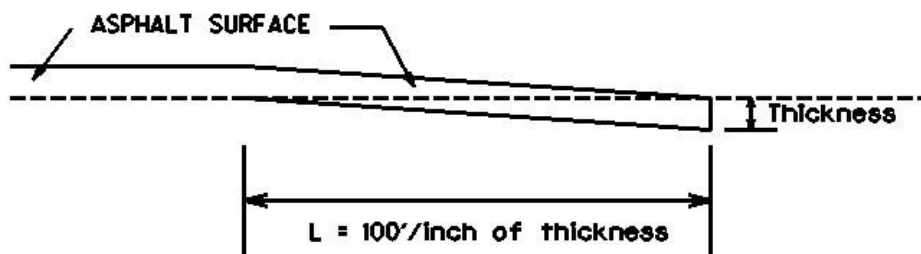

Thickness = 1.00 Inches

L = 100 LF

L = Length of Edge Key

**SPECIAL NOTE FOR
ASPHALT MILLING AND TEXTURING
KY 1120**

Begin paving operations no later than **48 hours** after the commencement of the asphalt milling operation. Continue paving operations continuously until completed. If paving operations are not begun within this time period, liquidated damages will be assessed at the rate prescribed by Section 108.09 of the current Standard Specifications until such time as paving operations are begun.

Contrary to Section 408 of the current Standard Specifications, the material obtained from the milling operations shall become the property of the Department. Deliver this material to the State Maintenance facility in Campbell County.

Notice to Contractor

Transfer of millings to the state maintenance facility is considered a part of the construction project, therefore truck operators are subject to receiving prevailing wages.

**SPECIAL NOTE FOR
ASPHALT MILLING AND TEXTURING
KY 547**

Begin paving operations no later than **TWO WEEKS** after the commencement of the asphalt milling operation. Continue paving operations continuously until completed. If paving operations are not begun within this time period, liquidated damages will be assessed at the rate prescribed by Section 108.09 of the current Standard Specifications until such time as paving operations are begun.

Contrary to Section 408 of the current Standard Specifications, the material obtained from the milling operations shall become the property of the Department. Deliver this material to the State Maintenance facility in Campbell County.

Notice to Contractor

Transfer of millings to the state maintenance facility is considered a part of the construction project, therefore truck operators are subject to receiving prevailing wages.

SPECIAL NOTES FOR BASE FAILURE REPAIR KY 1120

Repair locations listed in the summary are approximate only. Actual base failure repair locations will be determined by the Engineer before the resurfacing begins. Saw cut the existing pavement, asphalt surface, base, DGA, and brick and PCC pavement (if present). Excavate to an approximate depth of 12 inches below the existing pavement surface level. Remove and dispose of all materials. Use all possible care to avoid damaging existing culvert pipes and any existing underground utilities. Repair or restore any damaged items at no additional costs to the Department. Waste all removed materials off the Right of Way at sites obtained by the Contractor.

On the same day the trench is excavated, backfill the excavated area with 6 inches of #23 stone wrapped in Table III geotextile fabric on the bottom and sides of the excavated area. Backfill the remaining area with Class 2 Asphalt Base 1.0D PG64-22 in 3 inch maximum courses up to the existing pavement surface. Seal the Asphalt Base with Leveling and Wedging. Compact each course of asphalt base to the proper compaction as required by the Section 403. Seal the asphalt base with leveling and wedging material. Perform all base failure repairs in such a manner that removal and replacement are completed on the same day. Do this work prior to milling in order to allow further compaction by traffic. Do not mill or place new asphalt surface over repaired base failure areas until a minimum of 7 calendar days has elapsed after placement of the final course of asphalt base. Prior to constructing the new asphalt surface, level and wedge any settlement of the repair areas.

The bidder must draw his own conclusions as to the conditions encountered. The Department does not give any guarantee as to the accuracy of the data and no claim will be considered for additional compensation of the materials encountered that are not in accord with the classification shown.

Payment at the Contract unit prices per Square Yard for "Base Failure Repair" shall be full compensation for all labor, materials, equipment, and incidentals for saw cutting pavement, excavating and disposing of all materials, furnishing and placing #23 stone wrapped in Table III - geotextile fabric, backfilling trench up to the pavement boundary, furnishing, placing the asphalt base, and all other items necessary to complete the work to the satisfaction of the Engineer. Level and wedge will be paid as per the Standard Specifications.

SPECIAL NOTES FOR BASE FAILURE REPAIR KY 547

Repair locations listed in the summary are approximate only. Actual base failure repair locations will be determined by the Engineer before the resurfacing begins. Saw cut the existing pavement, asphalt surface, base, DGA, and and PCC pavement (if present). Excavate to an approximate depth of 12 inches below the existing pavement surface level. Remove and dispose of all materials. Use all possible care to avoid damaging existing culvert pipes and any existing underground utilities. Repair or restore any damaged items at no additional costs to the Department. Waste all removed materials off the Right of Way at sites obtained by the Contractor.

On the same day the trench is excavated, backfill the excavated area with 8 inches of #23 stone wrapped in Table III geotextile fabric on the bottom and sides of the excavated area. Backfill the remaining area with Class 2 Asphalt Base 1.0D PG64-22 in 4 inch maximum courses up to the existing pavement surface. Seal the Asphalt Base with Leveling and Wedging. Compact each course of asphalt base to the proper compaction as required by the Section 403. Seal the asphalt base with leveling and wedging material. Perform all base failure repairs in such a manner that removal and replacement are completed on the same day. Do this work prior to milling in order to allow further compaction by traffic. Do not mill, level & wedge, or place new asphalt surface over repaired base failure areas until a minimum of 7 calendar days has elapsed after placement of the final course of asphalt base. Prior to constructing the new asphalt surface, level and wedge any settlement of the repair areas.

The bidder must draw his own conclusions as to the conditions encountered. The Department does not give any guarantee as to the accuracy of the data and no claim will be considered for additional compensation of the materials encountered that are not in accord with the classification shown.

Payment at the Contract unit prices per Square Yard for "Base Failure Repair" shall be full compensation for all labor, materials, equipment, and incidentals for saw cutting pavement, excavating and disposing of all materials, furnishing and placing #23 stone wrapped in Table III - geotextile fabric, backfilling trench up to the pavement boundary, furnishing, placing the asphalt base, and all other items necessary to complete the work to the satisfaction of the Engineer. Level and wedge will be paid as per the Standard Specifications.

SPECIAL NOTE FOR TYPICAL SECTION DIMENSIONS

The dimensions shown on the typical sections for pavement and shoulder widths and thickness' are nominal or typical dimensions. The actual dimensions to be constructed may be varied to fit existing conditions as directed or approved by the Engineer. It is not intended that existing pavement or shoulders be widened unless specified elsewhere in the Proposal.

1-3725 typical section
01/01/2009

SPECIAL NOTE FOR SIDEWALK RAMPS & DETECTABLE WARNINGS KY 1120

GENERAL

Unless otherwise stated in the contract, or as directed by or with prior approval from the Engineer, construct Sidewalk Ramps and Detectable Warnings in accordance with Section 505 of the 2008 Standard Specifications; Supplemental Specifications, current edition; Standard Drawings RPM-160 and RPM-172, current editions; and Sepia Drawings 012, 013, 014, and 015, current editions. Modify layout and dimensions shown on the Standard and Sepia Drawings as approved by the Engineer to meet existing conditions. Saw cut existing sidewalks, curb and gutter, and pavement, if present, as directed by the Engineer. The sidewalk thickness specified in the contract is the nominal minimum required thickness; transition the thickness as directed by the Engineer if the existing sidewalk thickness is found to be greater or less than the thickness specified.

Except as required by the work, do not disturb drainage pipe, catch basins, and other roadway features, appurtenances and installations. Restore any roadway features, appurtenances and installations damaged by the work in like kind materials and design at no additional cost to the Department. Dispose of all waste off the right of way at sites obtained by the Contractor at no additional cost to the Department (see Special Note for Waste and Borrow).

MEASUREMENT & PAYMENT

SIDEWALK RAMPS – The Department will measure Sidewalk Ramps as Sidewalk - 4 Inch Concrete in accordance with Section 505.04. Payment at the Contract unit price per square yard shall be full compensation for all labor, materials, equipment, and incidentals required for saw cutting, removal and disposal of existing sidewalk, curb and gutter, and pavement; undercut excavation, backfill, and embankment; construction of the sidewalk ramps, reconstruction of the adjacent curb and/or sidewalk as necessary to install the sidewalk ramps; and restoration of disturbed features in accordance with these notes or as directed by the Engineer.

DETECTABLE WARNINGS EXISTING RAMPS – The Department will measure Detectable Warnings in accordance with the Supplemental Specifications and Sepia Drawing 015, current editions. Payment at the Contract unit price per square foot shall be full compensation for all labor, materials, equipment, and incidentals required for saw cutting, removal and disposal of existing sidewalk, curb and gutter; under cut excavation and backfill if required; construction of the detectable warnings in the existing sidewalk ramps; reconstruction of the adjacent sidewalk, curb and/or gutter as necessary to install the detectable warnings; and restoration of disturbed features in accordance with these notes or as directed by the Engineer

DETECTABLE WARNINGS NEW RAMPS – The Department will measure and pay for Detectable Warnings in accordance with the Supplemental Specifications and Sepia Drawing 015, current editions.

TRAFFIC CONTROL PLAN KY 547

TRAFFIC CONTROL GENERAL

Except as provided herein, maintain and control traffic in accordance with the 2008 Standard and Supplemental Specifications, and the Standard and Sepia Drawings and Special provisions, current editions. Except for the roadway and traffic control bid items listed, all items of work necessary to maintain and control traffic will be paid at the lump sum bid price to "Maintain and Control Traffic".

Contrary to Section 106.01, traffic control devices used on this project may be new, or used in like new condition, at the beginning of the work and maintained in like new condition until completion of the work.

PROJECT PHASING & CONSTRUCTION PROCEDURES

At the discretion of the Engineer, days and hours may be specified when lane closures will not be allowed.

Maintain alternating one way traffic during construction. Provide a minimum clear lane width of 10 feet; however, provide for passage of vehicles of up to 16 feet in width. If traffic should be stopped due to construction operations, and a school bus on an official run arrives on the scene, the Contractor shall make provisions for the passage of the bus as quickly as possible.

On the AA Highway exit ramps, do not allow traffic to queue within 100 feet of the mainline exit gores.

LANE CLOSURES

Do not leave lane closures in place during non-working hours.

SIGNS

Contrary to section 112.04.02, only long term signs (signs intended to be continuously in place for more than 3 days) will be measured for payment; short term signs (signs intended to be left in place for 3 days or less) will not be measured for payment but will be incidental to Maintain and Control Traffic.

Traffic Control Plan
KY 547
Page 2 of 2

BARRICADES

Barricades used in lieu of barrels and cones for channelization or delineation will be incidental to Maintain and Control Traffic according to Section 112.04.01. Barricades used to protect pavement removal areas will be bid as each according to Section 112.04.04.

THERMOPLASTIC INTERSECTION MARKING

All items required for lane closures related to this item of work shall be considered incidental to bid item "Maintain and Control Traffic". The Contractor shall be required to locate, document, and replace the markings that are existing in the field prior to the completion of project or as directed by Engineer.

PAVEMENT EDGE DROP-OFFS

A pavement edge between opposing directions of traffic or lanes that traffic is expected to cross in a lane change situation shall not have an elevation difference greater than 1½". Warning signs (MUTCD W8-9 or W8-9A, or W8-11) shall be placed in advance of and at 1500' intervals throughout the drop-off area. Dual posting on both sides of the traveled way shall be required. All transverse transitions between newly surfaced pavement and the existing pavement areas that traffic may cross shall be wedged with asphalt mixture for leveling and wedging. Remove the wedge prior to placement of the final surface course.

Pavement edges that traffic is not expected to cross, except accidentally, shall be treated as follows:

Less than 2" - No protection required.

2" to 4" - Place plastic drums, vertical panels, or barricades every 50 feet. Cones may be used in place of plastic drums, panels, and barricades during daylight working hours. Wedge with asphalt mixture for leveling and wedging with a 1:1 or flatter slope in daylight hours, or 3:1 or flatter slope during nighttime hours, when work is not active in the drop-off area.

Base Failures - Place plastic drums, vertical panels, or barricades every 25 feet. Cones may be used in place of plastic drums, panels, and barricades during daylight working hours. Place Type III barricades in front of open trench facing oncoming traffic in both directions. Backfill trench with asphalt base the same day it is excavated. Wedge with cuttings from trench with a 1:1 or flatter slope in daylight hours, or 3:1 or flatter slope during nighttime hours, when work is not active in the drop-off area.

TRAFFIC CONTROL PLAN KY 1120

TRAFFIC CONTROL GENERAL

Except as provided herein, maintain and control traffic in accordance with the 2008 Standard and Supplemental Specifications, and the Standard and Sepia Drawings and Special provisions, current editions. Except for the roadway and traffic control bid items listed, all items of work necessary to maintain and control traffic will be paid at the lump sum bid price to "Maintain and Control Traffic".

Contrary to Section 106.01, traffic control devices used on this project may be new, or used in like new condition, at the beginning of the work and maintained in like new condition until completion of the work.

PROJECT PHASING & CONSTRUCTION PROCEDURES

Do not erect any lane closures and maintain all lanes open to traffic during the following days and hours:

6:00 a.m. – 9:00 a.m.	Monday through Friday
3:00 p.m. – 6:00 p.m.	Monday through Friday
September 5, 2010	Riverfest Festival
As Directed by the Engineer	Cincinnati Bengals Football Game Days
As Directed by the Engineer	Cincinnati Reds Baseball Game Days

At the discretion of the Engineer, additional days and hours may be specified when lane closures will not be allowed.

During allowable days and hours, maintain alternating one way traffic on 11th Street during construction. Maintain a minimum of one lane of traffic southbound on York Street at all times during construction. Maintain a minimum of one lane of traffic in each direction on the Shortway Bridge at all times during construction. Provide a minimum clear lane width of 10 feet; however, make provisions for passage of vehicles of up to 16 feet in width. If traffic should be stopped due to construction operations, and a school bus on an official run arrives on the scene, the Contractor shall make provisions for the passage of the bus as quickly as possible.

The Engineer will permit night work. Obtain approval of the method of lighting prior to performing night work.

Traffic Control Plan
KY 1120
Page 2 of 4

Allow new pavement to cool sufficiently to prevent deformation by traffic before reopening a closed lane to traffic. Correct any deformed pavement as directed by the engineer at no additional cost to the Department. Take this and other Traffic Control Plan restrictions into account in preparing bid. The Department will not consider any claims or make additional payment for any delays to the contractor as a result of these restrictions.

LANE CLOSURES

Do not leave lane closures in place during non-working hours. Do not concurrently close more than one parking lane.

SIGNS

Contrary to section 112.04.02, only long term signs (signs intended to be continuously in place for more than 3 days) will be measured for payment; short term signs (signs intended to be left in place for 3 days or less) will not be measured for payment but will be incidental to Maintain and Control Traffic.

BARRICADES

Barricades used in lieu of barrels and cones for channelization or delineation will be incidental to Maintain and Control Traffic according to Section 112.04.01. Barricades used to protect pavement removal areas will be bid as each according to Section 112.04.04.

TRAFFIC COORDINATOR

Furnish a Traffic Coordinator as per Section 112 for an unclassified project. In addition to the requirements of Section 112, the Traffic Coordinator shall provide for inspection of the project maintenance of traffic once every two hours during the Contractor's operations and at any time a lane closure is in place. Provide traffic control personnel with access on the project to a radio or telephone to be used in case of emergencies or accidents.

CHANGEABLE MESSAGE SIGNS

If deemed necessary by the Engineer, changeable message signs will be installed, operated, and maintained by the Department.

Traffic Control Plan
KY 1120
Page 3 of 4

ARROW PANELS

Use arrow panels as shown on the Standard Drawings or as directed by the Engineer. The Department will measure for payment the maximum number of arrow panels in concurrent use at the same time on a single day on all sections of the contract. The Department will measure individual arrow panels only once for payment, regardless of how many times they are set, reset, removed, and relocated during the duration of the project. The Department will not measure replacements for damaged arrow panels directed by the Engineer to be replaced due to poor condition or readability. Retain possession of the arrow panels upon completion of the work.

PAVEMENT MARKINGS

Contrary to Section 112.03.10, remove or cover the lenses of raised pavement markers that do not conform to the traffic control scheme in use during night time hours, or as directed by the Engineer. Replace or uncover lenses before a closed lane is reopened to traffic. No direct payment will be made for removing and replacing or covering and uncovering the lenses outside limits of milling and texturing or resurfacing, but shall be incidental to "Maintain and Control Traffic".

Coordinate the installation of all temporary and permanent striping with the Engineer. If there is a deviation from the existing striping plan, the Engineer will furnish a striping plan to the Contractor prior to the installation of any temporary or permanent markings.

Place temporary and permanent striping according to Sections 112 and 748, except that:

1. Place either temporary or permanent striping before opening a lane to traffic; and
2. If the Contractor's operations or phasing requires temporary markings that must be subsequently removed from the final surface course or bridge deck, use an approved removable lane tape. The Department will not measure removable lane tape for separate payment, but if used, will measure and pay removable lane tape as temporary striping.

THERMOPLASTIC INTERSECTION MARKING

All items required for lane closures related to this item of work shall be considered incidental to bid item "Maintain and Control Traffic". The Contractor shall be required to locate, document, and replace the markings that are existing in the field prior to the completion of project or as directed by Engineer.

Traffic Control Plan
KY 1120
Page 4 of 4

PAVEMENT EDGE DROP-OFFS

A pavement edge between opposing directions of traffic or lanes that traffic is expected to cross in a lane change situation shall not have an elevation difference greater than 1½". Warning signs (MUTCD W8-9 or W8-9A, or W8-11) shall be placed in advance of and at 1500' intervals throughout the drop-off area. Dual posting on both sides of the traveled way shall be required. All transverse transitions between newly surfaced pavement and the existing pavement areas that traffic may cross shall be wedged with asphalt mixture for leveling and wedging. Remove the wedge prior to placement of the final surface course.

Pavement edges that traffic is not expected to cross, except accidentally, shall be treated as follows:

Less than 2" - No protection required.

2" to 4" - Place plastic drums, vertical panels, or barricades every 50 feet. Cones may be used in place of plastic drums, panels, and barricades during daylight working hours. Wedge with asphalt mixture for leveling and wedging with a 1:1 or flatter slope in daylight hours, or 3:1 or flatter slope during nighttime hours, when work is not active in the drop-off area.

Base Failures - Place plastic drums, vertical panels, or barricades every 25 feet. During daylight working hours only, the Engineer will allow cones to be used in lieu of drums, panels, and barricades. Place Type III barricades in front of open trench facing oncoming traffic in both directions. Backfill trench with asphalt base the same day it is excavated. Wedge with cuttings from trench with a 1:1 or flatter slope in daylight hours, or 3:1 or flatter slope during nighttime hours, when work is not active in the drop-off area.

SPECIAL NOTES FOR TRAFFIC SIGNAL LOOP DETECTORS

Be advised there may be existing traffic signal loop detectors within the construction limits of the subject project. Notify the Engineer in writing, (2) weeks prior to beginning any work on the project.

The Engineer will contact and maintain liaison with the District Traffic Engineer to coordinate any necessary work.

CAMPBELL COUNTY

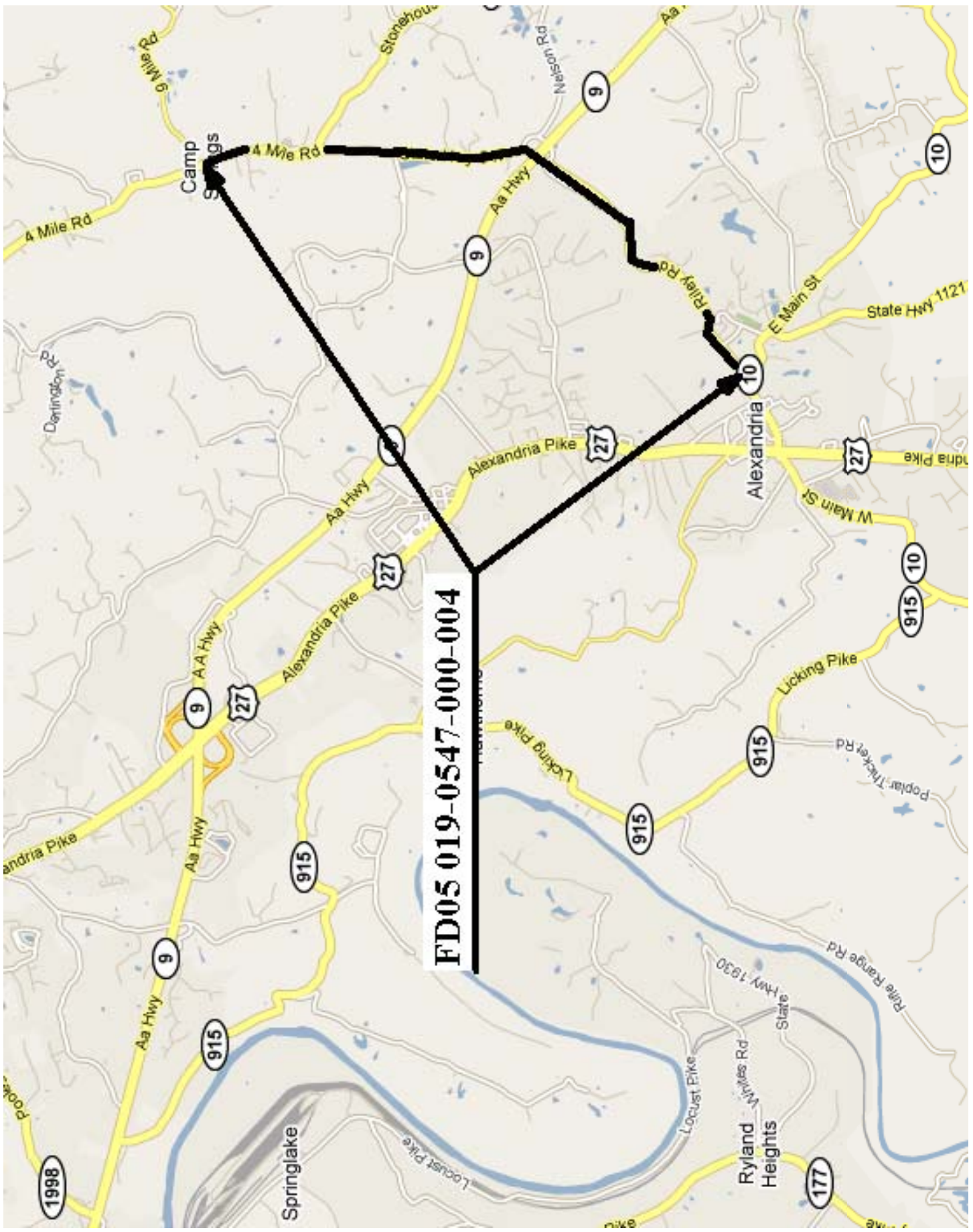

MATERIAL SUMMARY

CONTRACT ID: 102174

FD05 019 0547 000-004 PES NO: MP01905471001
RILEY ROAD-FOUR MILE ROAD (KY 547) FROM KY 10 (MP 0.000) EXTENDING NORTH TO NINE
MILE ROAD (MP 3.585), A DISTANCE OF 3.590000 MILES.

LINE NO	BID CODE	DESCRIPTION	QUANTITY	UNIT
0010	00190	LEVELING & WEDGING PG64-22	390.00	TON
0020	00301	CL2 ASPH SURF 0.38D PG64-22	2,830.00	TON
0030	02014	BARRICADE-TYPE III	2.00	EACH
0040	02562	SIGNS	270.00	SQFT
0050	02650	MAINTAIN & CONTROL TRAFFIC KY 547	1.00	LS
0060	02676	MOBILIZATION FOR MILL & TEXT KY 547	1.00	LS
0070	02677	ASPHALT PAVE MILLING & TEXTURING	40.00	TON
0080	03240	BASE FAILURE REPAIR KY 547	60.00	SQYD
0090	06510	PAVE STRIPING-TEMP PAINT-4 IN	10,000.00	LF
0100	06514	PAVE STRIPING-PERM PAINT-4 IN	77,500.00	LF
0110	06568	PAVE MARKING-THERMO STOP BAR-24IN	12.00	LF
0120	06574	PAVE MARKING-THERMO CURV ARROW	6.00	EACH
0130	10020NS	FUEL ADJUSTMENT	4,400.00	DOLL
0140	10030NS	ASPHALT ADJUSTMENT	7,750.00	DOLL
0150	02569	DEMOBILIZATION	1.00	LS

FD05 019 1120 000-001 PES NO: MP01911201001
WEST 11TH STREET (KY 1120) FROM SHORTWAY BRIDGE PCC APPROACH PAVEMENT AT BRIGHTON ST.
(MP 0.228) EXTENDING EAST TO YORK STREET (MP 0.668), A DISTANCE OF 0.440000 MILES.

LINE NO	BID CODE	DESCRIPTION	QUANTITY	UNIT
0015	00190	LEVELING & WEDGING PG64-22	50.00	TON
0010	00388	CL3 ASPH SURF 0.38B PG64-22	785.00	TON
0020	02014	BARRICADE-TYPE III	6.00	EACH
0030	02562	SIGNS	510.00	SQFT
0040	02650	MAINTAIN & CONTROL TRAFFIC KY 1120	1.00	LS
0050	02676	MOBILIZATION FOR MILL & TEXT KY 1120	1.00	LS
0060	02677	ASPHALT PAVE MILLING & TEXTURING	785.00	TON
0070	02720	SIDEWALK-4 IN CONCRETE	275.00	SQYD
0045	02775	ARROW PANEL	1.00	EACH
0080	03240	BASE FAILURE REPAIR KY 1120	236.00	SQYD
0090	06510	PAVE STRIPING-TEMP PAINT-4 IN	7,000.00	LF
0100	06514	PAVE STRIPING-PERM PAINT-4 IN	6,410.00	LF
0110	06565	PAVE MARKING-THERMO X-WALK-6 IN	1,878.00	LF
0120	06568	PAVE MARKING-THERMO STOP BAR-24IN	436.00	LF
0130	06573	PAVE MARKING-THERMO STR ARROW	2.00	EACH
0140	06574	PAVE MARKING-THERMO CURV ARROW	1.00	EACH
0150	06576	PAVE MARKING-THERMO ONLY	1.00	EACH
0160	10020NS	FUEL ADJUSTMENT	1,073.00	DOLL
0170	10030NS	ASPHALT ADJUSTMENT	1,891.00	DOLL
0180	23158ES505	DETECTABLE WARNINGS	354.00	SQFT
0190	02569	DEMOBILIZATION	1.00	LS

**CAMPBELL COUNTY
BASE FAILURE REPAIR SUMMARY
FD05 019 1120 000-001**

MILEPOINT	LENGTH	WIDTH
0.330	25	10
0.340	8	5
0.350	9	4
0.380	30	10
0.420	22	4
0.510	10	10
0.520	35	4
0.530	10	12
0.550	5	7
0.560	4	5
0.590	50	5
0.630	60	6
0.640	16	14
0.650	40	4

SIDEWALK RAMP LOCATION SUMMARY FD05 019-1120-000-001

Intersection	*Ramp Type	Corner Location				Area		Notes
		NE	SE	SW	NW	Sidewalk SY	Detectable Warnings SF	
Brighton Street	1	2	2			10	32	1, 2
	3			1	1	26	20	1, 2
Patterson Streer	1	2	2		2	35	48	1, 2
	3			1		14	10	1, 2
Isabella Street	1		2	2		22	32	1, 2
	3	1			1	22	20	1, 2
Liberty street	1	1	1	1	1	19	32	1, 2
Central Street (KY 9)	1	2	2	2		38	48	1, 2
	3				1	12	10	1, 2
Ann Street	1	1			1	16	16	1, 2
Columbia Street	1		1	1		9	16	1, 2
	3	1			1	21	20	1, 2
Putnam Street	1	2				12	16	1, 2
	3				1	4	8	1, 2
York Street (US 27)	1				2	11	16	1, 2
	3			1		7	10	1, 2
TOTALS		12	10	9	11	278	354	

- Notes:**
1. Approximate types and locations only. The Engineer will determine exact types and locations at time of construction.
 2. Modify Standard Drawings to meet existing conditions as approved by the Engineer.

TYPICAL SECTION
FD05 019-0547-000-004
MILEPOINTS 0.000 - 1.600
MILEPOINTS 1.891-3.585

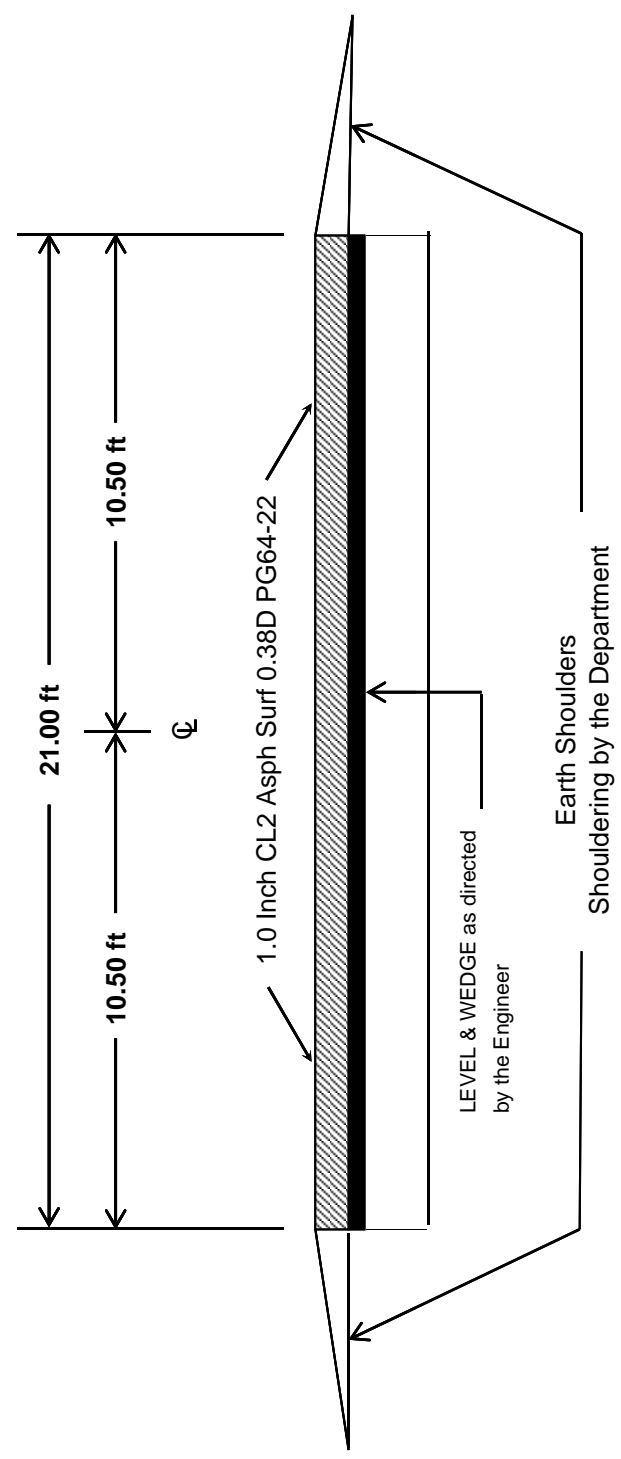

TYPICAL SECTION
FD05 019-0547-000-004
MILEPOINTS 0.000 - 1.600
MILEPOINTS 1.600 - 1.891

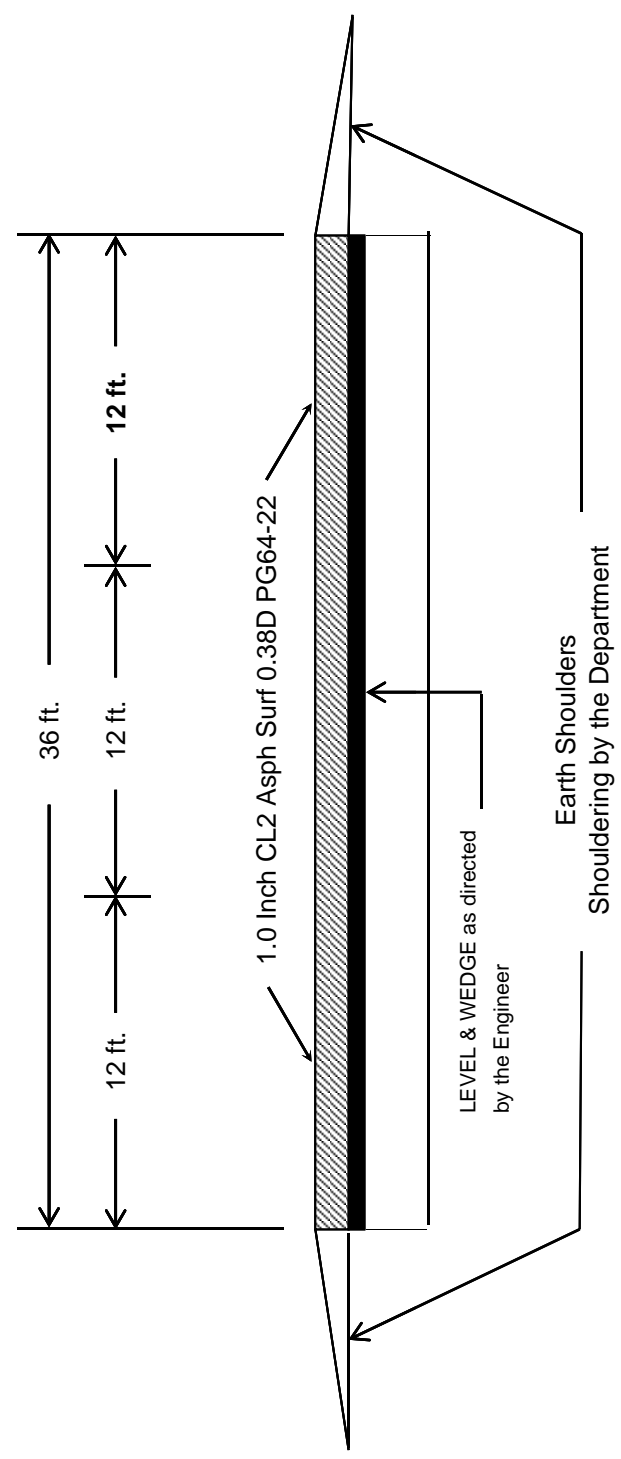

TYPICAL SECTION
FD05 019 1120 000-001
MILEPOINTS 0.228 - 0.668

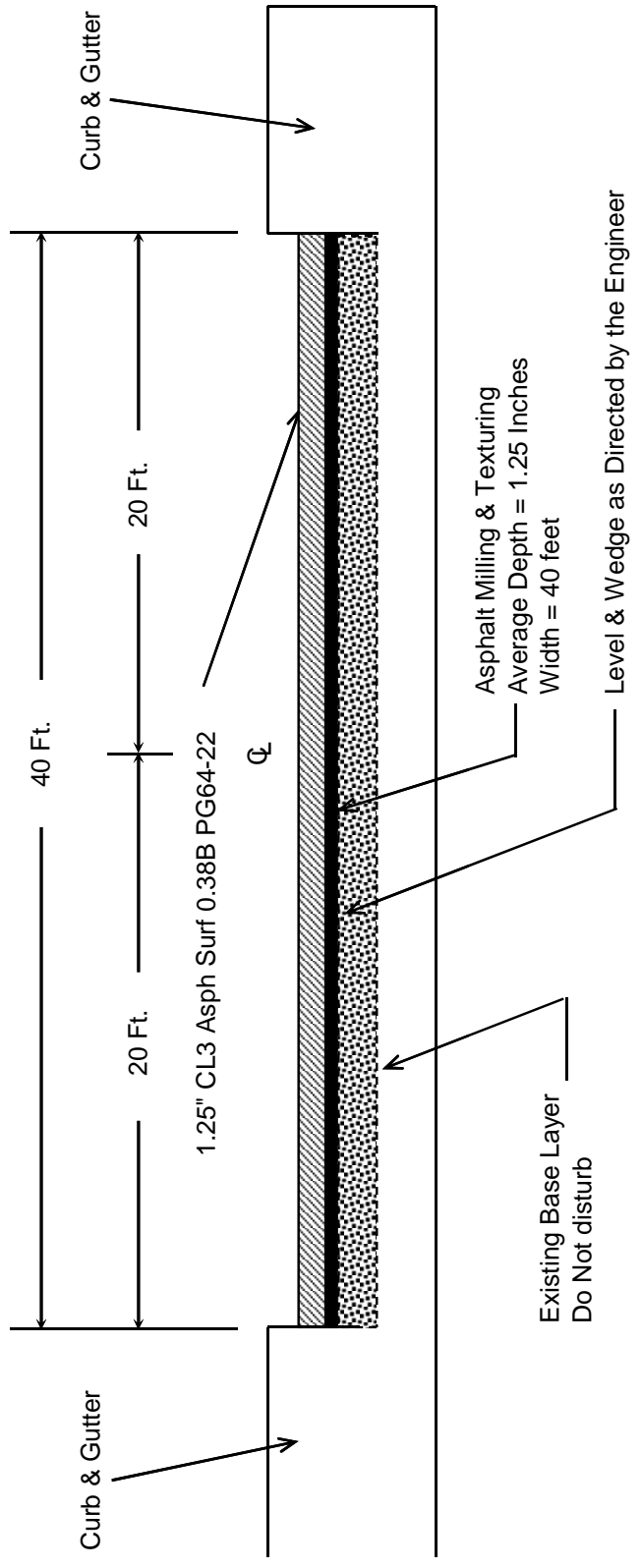

Note: See Special Notes for Base Failure Repair

PART II
SPECIFICATIONS AND STANDARD DRAWINGS

SPECIFICATIONS REFERENCE

Any reference in the plans or proposal to the *Standard Specifications for Road and Bridge Construction, Edition of 2004*, and *Standard Drawings, Edition of 2000* are superseded by *Standard Specifications for Road and Bridge Construction, Edition of 2008* and *Standard Drawings, Edition of 2003 with the 2008 Revision*.

**Supplemental Specifications to The Standard Specifications
for Road and Bridge Construction, 2008 Edition**
(Effective with the April 23, 2010 Letting)

<p>SUBSECTION: REVISION:</p>	<p>101.02 Abbreviations. Insert the following abbreviation and text into the section:</p> <p>KEPSC Kentucky Erosion Prevention and Sediment Control</p>
<p>SUBSECTION: REVISION:</p>	<p>101.03 Definitions. Replace the definition for Specifications – <i>Special Provisions</i> with the following:</p> <p>Additions and revisions to the Standard and Supplemental Specifications covering conditions peculiar to and individual project.</p>
<p>SUBSECTION: REVISION:</p>	<p>102.03 Replace the first sentence of the first paragraph with the following:</p> <p>Submit the Bid Proposal on forms furnished on the Department internet website (http://transportation.ky.gov/contract/), including the Bid Packet and disk created from the Expedite Bidding Program.</p> <p>Delete the last paragraph.</p>
<p>SUBSECTION: REVISION:</p>	<p>102.04 Issuance of Bid Proposal Form. Replace Heading with the following:</p> <p>102.04 Bidder Registration.</p> <p>Replace the first sentence of the first paragraph with the following:</p> <p>The Department reserves the right to disqualify or refuse to place a bidder on the eligible bidder’s list for a project for any of the following reasons:</p> <p>Replace the last sentence of the subsection with the following:</p> <p>The Department will resume placing the bidder on the eligible bidder’s list for projects after the bidder improves his operations to the satisfaction of the State Highway Engineer.</p>
<p>SUBSECTION: REVISION:</p>	<p>102.06 Examination of Plans, Specifications, Special Provisions, Special Notes, and Site of Work. Replace the first paragraph with the following:</p> <p>Examine the site of the proposed work, the Bid Proposal, Plans, specifications, contract forms, and bulletins and addendums posted to the Department’s website and the Bid Express Bidding Service Website before submitting the Bid Proposal. The Department considers the submission of a Bid Proposal prima facie evidence that the bidder has made such examination and is satisfied as to the conditions to be encountered in performing the work and as to the requirements of the Contract.</p>
<p>SUBSECTION: REVISION:</p>	<p>102.07.01 General. Replace the first sentence with the following:</p> <p>Submit the Bid Proposal on forms furnished on the Department internet website (http://transportation.ky.gov/contract/), including the Bid Packet and disk created from the Expedite Bidding Program.</p> <p>Insert the following after the first sentence of the third paragraph:</p> <p>Bid proposals submitted electronically shall use an eligible Digital ID issued by Bid Express.</p>

**Supplemental Specifications to The Standard Specifications
for Road and Bridge Construction, 2008 Edition**
(Effective with the April 23, 2010 Letting)

<p>SUBSECTION: REVISION:</p>	<p>102.07.02 Computer Bidding. Replace the first paragraph with the following:</p> <p>Subsequent to registering for a specific project, use the Department’s Expedite Bidding Program on the internet website of the Department of Highways, Division of Construction Procurement (http://transportation.ky.gov/contract/). Download the bid file from the Bid Express Bidding Service Website to prepare a Bid Proposal for submission to the Department. Include the completed Bid Packet produced by the Expedite Bidding Program and submit it along with the disk created by said program or submit electronically through Bid Express Bidding Service.</p> <p>Replace the second paragraph with the following:</p> <p>In case of a dispute, the printed Bid Proposal and bid item sheets created by the Expedite Bidding Program take precedence over any bid submittal.</p>
<p>SUBSECTION: REVISION:</p>	<p>102.08 Irregular Bid Proposals. Replace point four of the first paragraph with the following:</p> <p>4) fails to submit a disk created from the Expedite Bidding Program, unless the bid proposal is submitted electronically through the Bid Express Bidding Service.</p> <p>Replace point one of the second paragraph with the following:</p> <p>1) when the Bid Proposal is on a form other than that furnished by the Department or printed from other than the Expedite Bidding Program, or when the form is altered or any part is detached; or</p>
<p>SUBSECTION: REVISION:</p>	<p>102.09 Bid Proposal Guaranty. Insert the following after the first sentence:</p> <p>Bid proposals submitted electronically through Bid Express Bidding Service where a bid bond was not used must have a guaranty in the form of a cashier’s check or certified check in an amount no less than the amount indicated on the submitted electronic bid.</p>
<p>SUBSECTION: REVISION:</p>	<p>102.10 Delivery of Bid Proposals. Replace paragraph with the following:</p> <p>Return Bid Proposal in an envelope that is clearly marked indicating the contents. When sent by mail, address the sealed Bid Proposal to the Department at the address and in care of the office and official receiving the Bid Proposals. Submit all Bid Proposals prior to the time and at the place specified in the Notice to Contractors. The Department will time-stamp and return to the bidder unopened Bid Proposals received after the time for opening of bids. Bids submitted electronically shall be done using Bid Express Bidding Services. All bids submitted electronically must be done in accordance with the requirements of the Bid Express Bidding Service.</p>
<p>SUBSECTION: REVISION:</p>	<p>102.11 Withdrawal or Revision of Bid Proposals. Replace the paragraph with the following:</p> <p>A bidder may withdraw or revise a Bid Proposal after depositing the Bid Proposal with the Department, provided the Department receives the request for such withdrawal or revision in writing before the time set for opening Bid Proposals. Bid Proposals submitted electronically can be withdrawn in accordance the requirements of the Bid Express Bidding Service.</p>

**Supplemental Specifications to The Standard Specifications
for Road and Bridge Construction, 2008 Edition**
(Effective with the April 23, 2010 Letting)

<p>SUBSECTION: REVISION:</p>	<p>103.02 Award of Contract. Replace the first sentence of the third paragraph with the following:</p> <p>The Department will normally award the Contract within 10 working days after the date of receiving Bid Proposals unless the Department deems it best to hold the Bid Proposals of any or all bidders for a period not to exceed 60 calendar days for final disposition of award.</p>
<p>SUBSECTION: REVISION:</p>	<p>105.03 Record Plans. Replace the section with the following:</p> <p>Record Plans are those reproductions of the original Plans on which the accepted Bid Proposal was based and, and signed by a duly authorized representative of the Department. The Department will make these plans available for inspection in the Central Office at least 24 hours prior to the time of opening bids and up to the time of letting of a project or projects. The quantities appearing on the Record Plans are the same as those on which Bid Proposals are received. The Department will use these Record Plans as the controlling plans in the prosecution of the Contract. The Department will not make any changes on Record Plans subsequent to their issue unless done so by an approved contract modification. The Department will make 2 sets of Record Plans for each project, and will maintain one on file in the Central Office and one of file in the District Office. The Department will furnish the Contractor with the following: 1 full size, 2 half size and an electronic file copy of the Record Plans at the Pre-Construction conference.</p>
<p>SUBSECTION: REVISION:</p>	<p>105.12 Final Inspection and Acceptance of Work. Insert the following paragraphs after the first paragraph:</p> <p>Notify the Engineer when all electrical items are complete. A notice of the electrical work completion shall be made in writing to the Contractor. Electrical items will be inspected when the electrical work is complete and are not subject to waiting until the project as a whole has been completed. The Engineer will notify the Division of Traffic Operations within 3 days that all electrical items are complete and ready for a final inspection. A final inspection will be completed within 90 days after the Engineer notifies the Division of Traffic Operations of the electrical work completion.</p> <p>Energize all electrical items prior to notifying the Engineer that all electrical items are complete. Electrical items must remain operational until the Division of Traffic Operations has inspected and accepted the electrical portion of the project. Payment for the electrical service is the responsibility of the Contractor from the time the electrical items are energized until the Division of Traffic Operations has accepted the work.</p> <p>Complete all corrective work within 90 calendar days of receiving the original electrical inspection report. Notify the Engineer when all corrective work is complete. The Engineer will notify the Division of Traffic Operations that the corrective work has been completed and the project is ready for a follow-up inspection. Upon re-inspection, if additional corrective work is required, complete within the same 90 calendar day allowance. The Department will not include time between completion of the corrective work and the follow up electrical inspection(s). The 90 calendar day allowance is cumulative regardless of the number of follow-up electrical inspections required.</p> <p>The Department will assume responsibility for the electrical service on a project once the Division of Traffic Operations gives final acceptance of the electrical items on the project. The Department will also assume routine maintenance of those items. Any damage done to accepted electrical work items by other Contractors shall be the responsibility of the Prime Contractor. The Department will not be responsible for repairing damage done by other contractors during the construction of the remaining project.</p> <p>Failure to complete the electrical corrective work within the 90 calendar day allowance will result in penalties assessed to the project. Penalties will be assessed at ½ the rate of liquidated damages established for the contract.</p> <p>Replace the following in the second sentence of the second paragraph:</p> <p>Replace Section 213 with Section 212.</p> <p>Delete the fifth paragraph from the section.</p>

**Supplemental Specifications to The Standard Specifications
for Road and Bridge Construction, 2008 Edition
(Effective with the April 23, 2010 Letting)**

SUBSECTION: REVISION:	<p>105.13 Claim Resolution Process. Replace the last sentence of the 3. Bullet with the following:</p> <p>If the Contractor did not submit an as-bid schedule at the Pre-Construction Meeting or a written narrative in accordance with Subsection 108.02, the Cabinet will not consider the claim for delay.</p> <p>Delete the last paragraph from the section.</p>
SUBSECTION: REVISION:	<p>106.10 Field Welder Certification Requirements. Insert the following sentence before the first sentence of the first paragraph:</p> <p>All field welding must be performed by a certified welder unless otherwise noted.</p>
SUBSECTION: REVISION:	<p>108.02 Progress Schedule. Insert the following prior to the first paragraph:</p> <p>Specification 108.02 applies to all Cabinet projects except the following project types:</p> <ul style="list-style-type: none">● Right of Way Mowing and/or Litter Removal● Waterborne Paint Striping● Projects that contain Special Provision 82● Projects that contain the Special Note for CPM Scheduling <p>Insert the following paragraph after paragraph two:</p> <p>Working without the submittal of a Written Narrative is violation of this specification and additionally voids the Contractor's right to delay claims.</p> <p>Insert the following paragraph after paragraph six:</p> <p>The submittal of bar chart or Critical Path Method schedule does not relieve the Contractor's requirement to submit a Written Narrative schedule.</p> <p>Insert the following at the beginning of the first paragraph of A) Written Narrative.:</p> <p>Submit the Written Narrative Schedule using form TC 63-50 available at the Division of Construction's website (http://www.transportation.ky.gov/construction/ResCenter/ResCenter.htm).</p> <p>Replace Part A) Written Narrative 1. And 2. with the following:</p> <ol style="list-style-type: none">1. Provide a description that includes how the Contractor will sequence and stage the work, how the Contractor plans to maintain and control traffic being specific and detailed, and what equipment and crew sizes are planned to execute the work.2. Provide a list of project milestones including, if applicable, winter shut-downs, holidays, or special events. The Contractor shall describe how these milestones and other dates effect the prosecution of the work. Also, include start date and completion date milestones for the contract, each project if the contract entails multiple projects, each phase of work, site of work, or segment of work as divided in the project plans, proposal, or as subdivided by the Contractor.

**Supplemental Specifications to The Standard Specifications
for Road and Bridge Construction, 2008 Edition**
(Effective with the April 23, 2010 Letting)

<p>SUBSECTION: REVISION:</p>	<p>110.01 Mobilization. Replace paragraph three with the following:</p> <p>Do not bid an amount for Mobilization that exceeds 5 percent of the sum of the total amounts bid for all items in the Bid Proposal, excluding Mobilization, Demobilization, and contingent amounts established for adjustments and incentives. The Department will automatically adjust any Bid Proposals that are in excess of this amount down to 5 percent to compare Bid Proposals and award the Contract. The Department will award a Contract for the actual amount bid when the amount bid for Mobilization is less than 5 percent, or the Department will award the Contract for the adjusted bid amount of 5 percent when the amount bid for Mobilization is greater than 5 percent. If any errors in unit bid prices for other Contract items in a Contractor's Bid Proposal are discovered after bid opening and such errors reduce the total amount bid for all other items, excluding Mobilization, Demobilization, and contingent amounts established for adjustments and incentives, so that the percent bid for Mobilization is larger than 5 percent, the Department will adjust the amount bid for Mobilization to 5 percent of the sum of the corrected total bid amounts.</p>
<p>SUBSECTION: REVISION:</p>	<p>110.02 Demobilization. Replace the third paragraph with the following:</p> <p>Bid an amount for Demobilization that is a minimum of \$1,000 or 1.5 percent of the sum of the total amounts bid for all other items in the Bid Proposal, excluding Mobilization, Demobilization, and contingent amounts established for adjustments and incentives. The Department will automatically adjust any Bid Proposal that is less than this amount up to \$1,000 or 1.5 percent to compare Bid Proposals and award the Contract. The Department will award a Contract for the actual amount bid when the amount bid for demobilization exceeds 1.5 percent, or the Department will award the Contract for the adjusted bid amount when the amount bid for demobilization is less than the minimum of \$1,000 or less than 1.5 percent of the sum of the total amounts bid for all other items in the Bid Proposal, excluding Mobilization, Demobilization, and contingent amounts established for adjustments and incentives.</p>
<p>SUBSECTION: REVISION:</p>	<p>110.04 Payment. Insert the following paragraph following the demobilization payment schedule (4th paragraph):</p> <p>The Department will withhold an amount equal to \$1,000 for demobilization, regardless of the schedule listed above. The \$1,000 withheld for demobilization will be paid when the final estimate is paid.</p>
<p>SUBSECTION: REVISION:</p>	<p>112.03.01 General Traffic Control. Replace paragraph three with the following:</p> <p>All flaggers shall be trained in current MUTCD flagging procedures. Proof of training must be available for review at the Department's request. Flagging credentials must be current within the last 5 years.</p>
<p>SUBSECTION: PART: REVISION:</p>	<p>112.03.11 Temporary Pavement Markings. B) Placement and Removal of Temporary Striping. Replace the 2nd sentence of the first paragraph with the following:</p> <p>On interstates and parkways, and other roadways approved by the State Highway Engineer, install pavement striping that is 6 inches in width.</p>
<p>SUBSECTION: REVISION:</p>	<p>112.03.12 Project Traffic Coordinator (PTC). Add the following at the end of the subsection:</p> <p>After October 1, 2008 the Department will require the PTC to have successfully completed the applicable qualification courses. Personnel that have not successfully completed the applicable courses by that date will not be considered qualified. Prior to October 1, 2008, conform to Subsection 108.06 A) and ensure the designated PTC has sufficient skill and experience to properly perform the task.</p>

**Supplemental Specifications to The Standard Specifications
for Road and Bridge Construction, 2008 Edition**
(Effective with the April 23, 2010 Letting)

<p>SUBSECTION: REVISION:</p>	<p>112.03.15 Non-Compliance of Maintain and Control of Traffic. Add the following section:</p> <p>112.03.15 Non-Compliance of Maintain and Control of Traffic. It is the Contractor's responsibility to conform to the traffic control requirements in the TCP, Proposal, plan sheets, specifications, and the Manual on Uniform Traffic Control Devices.</p> <p>Unless specified elsewhere in the contract, a penalty will be assessed in the event of non-compliance with Maintain and Control of Traffic requirements. These penalties will be assessed when the Contractor fails to correct a situation or condition of non-compliance with the contract traffic control requirements after being notified by the Engineer. The calculation of accrued penalties for non-compliance will be based upon the date/time of notification by the Engineer.</p> <p>The amount of the penalty assessed for non-compliance will be determined based upon the work zone duration, as defined by the MUTCD, and will be the greatest of the different calculation methods indicated below:</p> <p>A) Long-term stationary work that occupies a location more than 3 days.</p> <p>Correct the non-compliant issue within 24 hours from initial notification by the Engineer. If the issue is not corrected within 24 hours from the initial notification, a penalty for non-compliance will be assessed on a daily basis beginning from the initial notification of non-compliance. The Contractor will be assessed a \$1,000 daily penalty or the amount equal to the contract liquidated damages in Section 108.09, whichever of the 2 is greater. The penalty for non-compliance will escalate as follows for continued non-compliance after the initial notification.</p> <p>3 Days after Notification \$1,500 daily penalty or 1.5 times the contract liquidated damages daily charge rate in Section 108.09, whichever is greater.</p> <p>7 Days after Notification \$2,000 daily penalty or double the contract liquidated damages daily charge rate in Section 108.09, whichever is greater.</p> <p>B) Intermediate-term stationary work that occupies a location more than one daylight period up to 3 days, or nighttime work lasting more than 1 hour.</p> <p>Correct the non-compliant issue within 4 hours from initial notification by the Engineer. If the issue is not corrected within 4 hours from notification, a penalty for non-compliance will be assessed on an hourly basis beginning from the initial notification of non-compliance. The penalty for non-compliance will be assessed at \$200 per hour.</p> <p>C) Short-term stationary is daytime work that occupies a location for more than 1 hour within a single daylight period.</p> <p>Correct the non-compliant issue within 1 hour from initial notification by the Engineer. If the issue is not corrected within 1 hour from notification, a penalty for non-compliance will be assessed on an hourly basis beginning from the initial notification of non-compliance. The penalty for non-compliance will be assessed at \$200 per hour.</p> <p>If the Contractor remains in violation of the Maintain and Control of Traffic requirements, or if the Department determines it to be in the public's interest, work will be suspended in accordance with Section 108.08 until the deficiencies are corrected. The Department reserves the right to correct deficiencies by any means available and charge the Contractor for labor, equipment, and material costs incurred in emergency situations.</p>
--	---

**Supplemental Specifications to The Standard Specifications
for Road and Bridge Construction, 2008 Edition**
(Effective with the April 23, 2010 Letting)

<p>SUBSECTION: REVISION:</p>	<p>206.03.02 Embankment Replace the last paragraph with the following:</p> <p>When rock roadbed is specified, construct the upper 2 feet of the embankment according to Subsection 204.03.09 A).</p>
<p>SUBSECTION: REVISION:</p>	<p>213.03.03 Inspection and Maintenance. Insert the following paragraph after the second paragraph:</p> <p>When the Contractor is required to obtain the KPDES permit, it is their responsibility to ensure compliance with the inspection and maintenance requirements of the permit. The Engineer will perform verification inspections a minimum of once per month and within 7 days of a ½ inch or greater rainfall event. The Engineer will document these inspections using Form TC 63-61 A. The Engineer will provide copies of the inspection only when improvements to the BMP's are required. Verification inspections performed by the Engineer do not relieve the Contractor of any responsibility for compliance with the KPDES permit. Initiate corrective action within 24 hours of any noted deficiency and complete the work within 5 days.</p>
<p>SUBSECTION: PART: REVISION:</p>	<p>213.03.05 Temporary Control Measures. E) Temporary Seeding and Protection. Replace the first paragraph with the following:</p> <p>Apply an Annual Rye seed mix at a rate of 100 pounds per acre during the months of March through August. In addition to the Annual Rye, add 10 pounds of German Foxtail-Millet (<i>Setaria italica</i>), when performing temporary seeding during the months of June through August. During the months of September through February, apply Winter Wheat or Rye Grain at a rate of 100 pounds per acre. Obtain the Engineer's approval prior to the application of the seed mixture.</p>
<p>SUBSECTION: PART: REVISION:</p>	<p>213.03.05 Temporary Control Measures. F) Temporary Mulch. Replace the last sentence with the following:</p> <p>Place temporary mulch to an approximate 2-inch loose depth (2 tons per acre) and anchor it into the soil by mechanically crimping it into the soil surface or applying tackifier to provide a protective cover. Regardless of the anchoring method used, ensure the protective cover holds until disturbance is required or permanent controls are in installed.</p>
<p>SUBSECTION: REVISION:</p>	<p>303.05 Payment. Replace the second paragraph of the section with the following:</p> <p>The Department will make payment for Drainage Blanket-Type II (ATDB) according to the Lot Pay Adjustment Schedule for Specialty Mixtures in Section 402.</p>
<p>SUBSECTION: PART: REVISION:</p>	<p>401.02.04 Special Requirements for Dryer Drum Plants. F) Production Quality Control. Replace the first sentence with the following:</p> <p>Stop mixing operations immediately if, at any time, a failure of the automatic electronic weighing system of the aggregate feed, asphalt binder feed, or water injection system control occurs.</p>

**Supplemental Specifications to The Standard Specifications
for Road and Bridge Construction, 2008 Edition**
(Effective with the April 23, 2010 Letting)

SUBSECTION: REVISION:	<p>401.02.04 Special Requirements for Dryer Drum Plants. Add the following:</p> <p>Part G) Water Injection System. Provided each system has prior approval as specified in Subsection 402.01.01, the Department will allow the use of water injection systems for purposes of foaming the asphalt binder and lowering the mixture temperature for production of Warm Mix Asphalt (WMA). Ensure the equipment for water injection meets the following requirements:</p> <ol style="list-style-type: none"> 1) Injection equipment computer controls are automatically coupled to the plants controls (manual operation is not permitted); 2) Injection equipment has variable controls that introduce water ratios based on production rates of mixtures; 3) Injects water into the flow of asphalt binder prior to contacting the aggregate; 4) Provides alarms on the water injection system that operate when the flow of water is interrupted or deviates from the prescribed water rate. 																																																	
SUBSECTION: REVISION:	<p>401.03.01 Preparation of Mixtures. Replace the last sentence of the second paragraph with the following:</p> <p>Do not use asphalt binder while it is foaming in a storage tank.</p>																																																	
SUBSECTION: REVISION:	<p>401.03.01 Preparation of Mixtures. Replace the third paragraph and Mixing and Laying Temperature table with the following:</p> <p>Maintain the temperature of the component materials and asphalt mixture within the ranges listed in the following table:</p> <table border="1" style="width: 100%; border-collapse: collapse;"> <thead> <tr> <th colspan="4" style="text-align: center;">MIXING AND LAYING TEMPERATURES (°F)</th> </tr> <tr> <th style="width: 40%;">Material</th> <th style="width: 20%;"></th> <th style="width: 20%;">Minimum</th> <th style="width: 20%;">Maximum</th> </tr> </thead> <tbody> <tr> <td>Aggregates</td> <td></td> <td align="center">240</td> <td align="center">330</td> </tr> <tr> <td>Aggregates used with Recycled Asphalt Pavement (RAP)</td> <td></td> <td align="center">240</td> <td align="center">—</td> </tr> <tr> <td rowspan="2">Asphalt Binders</td> <td>PG 64-22</td> <td align="center">230</td> <td align="center">330</td> </tr> <tr> <td>PG 76-22</td> <td align="center">285</td> <td align="center">350</td> </tr> <tr> <td rowspan="4">Asphalt Mixtures at Plant (Measured in Truck)</td> <td>PG 64-22 HMA</td> <td align="center">250</td> <td align="center">330</td> </tr> <tr> <td>PG 76-22 HMA</td> <td align="center">310</td> <td align="center">350</td> </tr> <tr> <td>PG 64-22 WMA</td> <td align="center">230</td> <td align="center">275</td> </tr> <tr> <td>PG 76-22 WMA</td> <td align="center">250</td> <td align="center">300</td> </tr> <tr> <td rowspan="4">Asphalt Mixtures at Project (Measured in Truck When Discharging)</td> <td>PG 64-22 HMA</td> <td align="center">230</td> <td align="center">330</td> </tr> <tr> <td>PG 76-22 HMA</td> <td align="center">300</td> <td align="center">350</td> </tr> <tr> <td>PG 64-22 WMA</td> <td align="center">210</td> <td align="center">275</td> </tr> <tr> <td>PG 76-22 WMA</td> <td align="center">240</td> <td align="center">300</td> </tr> </tbody> </table>	MIXING AND LAYING TEMPERATURES (°F)				Material		Minimum	Maximum	Aggregates		240	330	Aggregates used with Recycled Asphalt Pavement (RAP)		240	—	Asphalt Binders	PG 64-22	230	330	PG 76-22	285	350	Asphalt Mixtures at Plant (Measured in Truck)	PG 64-22 HMA	250	330	PG 76-22 HMA	310	350	PG 64-22 WMA	230	275	PG 76-22 WMA	250	300	Asphalt Mixtures at Project (Measured in Truck When Discharging)	PG 64-22 HMA	230	330	PG 76-22 HMA	300	350	PG 64-22 WMA	210	275	PG 76-22 WMA	240	300
MIXING AND LAYING TEMPERATURES (°F)																																																		
Material		Minimum	Maximum																																															
Aggregates		240	330																																															
Aggregates used with Recycled Asphalt Pavement (RAP)		240	—																																															
Asphalt Binders	PG 64-22	230	330																																															
	PG 76-22	285	350																																															
Asphalt Mixtures at Plant (Measured in Truck)	PG 64-22 HMA	250	330																																															
	PG 76-22 HMA	310	350																																															
	PG 64-22 WMA	230	275																																															
	PG 76-22 WMA	250	300																																															
Asphalt Mixtures at Project (Measured in Truck When Discharging)	PG 64-22 HMA	230	330																																															
	PG 76-22 HMA	300	350																																															
	PG 64-22 WMA	210	275																																															
	PG 76-22 WMA	240	300																																															
SUBSECTION: REVISION:	<p>402.01 Description. Replace the paragraph with the following:</p> <p>Provide the process control and acceptance testing of all classes and types of asphalt mixtures which may be furnished either as hot mix asphalt (HMA) or warm mix asphalt (WMA) produced with water injection systems.</p>																																																	

**Supplemental Specifications to The Standard Specifications
for Road and Bridge Construction, 2008 Edition**
(Effective with the April 23, 2010 Letting)

<p>SUBSECTION: REVISION:</p>	<p>402.01.01 Warm Mix Asphalt (WMA) Evaluation and Approval. Add the following subsection:</p> <p>402.01.01 Warm Mix Asphalt (WMA) Evaluation and Approval. The Department will evaluate trial production of WMA by use of a water injection system provided the system is installed according to the manufacturer's requirements and satisfies the requirements of Section 401. Evaluation will include production and placement of WMA to demonstrate adequate mixture quality including volumetric properties and density by Option A as specified in Subsection 402.03.02 D). Do not place WMA for evaluation on Department projects. Provided production and placement operations satisfy the applicable quality levels, the Department will approve WMA production on Department projects using the water injection system as installed on the specific asphalt mixing plant evaluated.</p>												
<p>SUBSECTION: REVISION:</p>	<p>402.05.02 Asphalt Mixtures and Mixtures With RAP. Replace Subsection Title as below:</p> <p>402.05.02 Asphalt Mixtures, HMA and WMA, Including Mixtures With RAP.</p>												
<p>SUBSECTION: REVISION:</p>	<p>402.05.02 Asphalt Mixtures, HMA and WMA, Including Mixtures With RAP. Replace the paragraph with the following:</p> <p>The Department will pay for the mixture at the Contract unit bid price and apply a Lot Pay Adjustment for each lot placed based on the degree of compliance with the specified tolerances. Using the appropriate Lot Pay Adjustment Schedule, the Department will assign a pay value for the applicable properties within each subplot and average the subplot pay values to determine the pay value for a given property for each lot. The Department will apply the Lot Pay Adjustment for each lot to a defined unit price of \$50.00 per ton. The Department will calculate the Lot Pay Adjustment using all possible incentives and disincentives but will not allow the overall pay value for a lot to exceed 1.00.</p>												
<p>SUBSECTION: PART: REVISION:</p>	<p>402.05.02 Asphalt Mixtures, HMA and WMA, Including Mixtures With RAP. C) Conventional and RAP Mixtures Placed on Shoulders. Replace title with the following:</p> <p>HMA, WMA, and RAP Mixtures Placed on Shoulders.</p>												
<p>SUBSECTION: PART: REVISION:</p>	<p>402.05.02 Asphalt Mixtures, HMA and WMA, Including Mixtures With RAP. D) Conventional and RAP Mixtures Placed Monolithically as Asphalt Pavement Wedge. Replace the title with the following:</p> <p>HMA, WMA, and RAP Mixtures Placed Monolithically as Asphalt Pavement Wedge.</p>												
<p>SUBSECTION: PART: TABLES: REVISION:</p>	<p>402.05.02 Asphalt Mixtures, HMA and WMA, Including Mixtures With RAP. Lot Pay Adjustment Schedule, Compaction Option A, Base and Binder Mixtures VMA Replace the VMA table with the following:</p> <table border="1" data-bbox="753 1583 1118 1801"> <thead> <tr> <th colspan="2" style="text-align: center;">VMA</th> </tr> <tr> <th style="text-align: center;">Pay Value</th> <th style="text-align: center;">Deviation From Minimum</th> </tr> </thead> <tbody> <tr> <td style="text-align: center;">1.00</td> <td style="text-align: center;">• min. VMA</td> </tr> <tr> <td style="text-align: center;">0.95</td> <td style="text-align: center;">0.1-0.5 below min.</td> </tr> <tr> <td style="text-align: center;">0.90</td> <td style="text-align: center;">0.6-1.0 below min.</td> </tr> <tr> <td style="text-align: center;">(1)</td> <td style="text-align: center;">> 1.0 below min.</td> </tr> </tbody> </table>	VMA		Pay Value	Deviation From Minimum	1.00	• min. VMA	0.95	0.1-0.5 below min.	0.90	0.6-1.0 below min.	(1)	> 1.0 below min.
VMA													
Pay Value	Deviation From Minimum												
1.00	• min. VMA												
0.95	0.1-0.5 below min.												
0.90	0.6-1.0 below min.												
(1)	> 1.0 below min.												

**Supplemental Specifications to The Standard Specifications
for Road and Bridge Construction, 2008 Edition
(Effective with the April 23, 2010 Letting)**

<p>SUBSECTION: PART: TABLES: REVISION:</p>	<p>402.05.02 Asphalt Mixtures, HMA and WMA, Including Mixtures With RAP. Lot Pay Adjustment Schedule, Compaction Option A, Surface Mixtures VMA Replace the VMA table with the following:</p> <table border="1" data-bbox="738 390 1102 642"> <thead> <tr> <th colspan="2">VMA</th> </tr> <tr> <th>Pay Value</th> <th>Deviation From Minimum</th> </tr> </thead> <tbody> <tr> <td>1.00</td> <td>• min. VMA</td> </tr> <tr> <td>0.95</td> <td>0.1-0.5 below min.</td> </tr> <tr> <td>0.90</td> <td>0.6-1.0 below min.</td> </tr> <tr> <td>(1)</td> <td>> 1.0 below min.</td> </tr> </tbody> </table>	VMA		Pay Value	Deviation From Minimum	1.00	• min. VMA	0.95	0.1-0.5 below min.	0.90	0.6-1.0 below min.	(1)	> 1.0 below min.											
VMA																								
Pay Value	Deviation From Minimum																							
1.00	• min. VMA																							
0.95	0.1-0.5 below min.																							
0.90	0.6-1.0 below min.																							
(1)	> 1.0 below min.																							
<p>SUBSECTION: PART: TABLE: REVISION:</p>	<p>402.05.02 Asphalt Mixtures, HMA and WMA, Including Mixtures With RAP. Lot Pay Adjustment Schedule, Compaction Option B Mixtures VMA Replace the VMA table with the following:</p> <table border="1" data-bbox="743 814 1107 1066"> <thead> <tr> <th colspan="2">VMA</th> </tr> <tr> <th>Pay Value</th> <th>Deviation From Minimum</th> </tr> </thead> <tbody> <tr> <td>1.00</td> <td>• min. VMA</td> </tr> <tr> <td>0.95</td> <td>0.1-0.5 below min.</td> </tr> <tr> <td>0.90</td> <td>0.6-1.0 below min.</td> </tr> <tr> <td>(2)</td> <td>> 1.0 below min.</td> </tr> </tbody> </table>	VMA		Pay Value	Deviation From Minimum	1.00	• min. VMA	0.95	0.1-0.5 below min.	0.90	0.6-1.0 below min.	(2)	> 1.0 below min.											
VMA																								
Pay Value	Deviation From Minimum																							
1.00	• min. VMA																							
0.95	0.1-0.5 below min.																							
0.90	0.6-1.0 below min.																							
(2)	> 1.0 below min.																							
<p>SUBSECTION: PART: NUMBER: REVISION:</p>	<p>403.03.03 Preparation of Mixture. C) Mix Design Criteria. 1) Preliminary Mix Design. Replace the last two sentences of the paragraph and table with the following:</p> <p>Complete the volumetric mix design at the appropriate number of gyrations as given in the table below for the number of 20-year ESAL's. The Department will define the relationship between ESAL classes, as given in the bid items for Superpave mixtures, and 20-year ESAL ranges as follows:</p> <table border="1" data-bbox="566 1358 1273 1514"> <thead> <tr> <th rowspan="2">Class</th> <th rowspan="2">ESAL's (millions)</th> <th colspan="3">Number of Gyration</th> </tr> <tr> <th>$N_{initial}$</th> <th>N_{design}</th> <th>N_{max}</th> </tr> </thead> <tbody> <tr> <td>2</td> <td>< 3.0</td> <td>6</td> <td>50</td> <td>75</td> </tr> <tr> <td>3</td> <td>3.0 to < 30.0</td> <td>7</td> <td>75</td> <td>115</td> </tr> <tr> <td>4</td> <td>≥ 30.0</td> <td>8</td> <td>100</td> <td>160</td> </tr> </tbody> </table>	Class	ESAL's (millions)	Number of Gyration			$N_{initial}$	N_{design}	N_{max}	2	< 3.0	6	50	75	3	3.0 to < 30.0	7	75	115	4	≥ 30.0	8	100	160
Class	ESAL's (millions)			Number of Gyration																				
		$N_{initial}$	N_{design}	N_{max}																				
2	< 3.0	6	50	75																				
3	3.0 to < 30.0	7	75	115																				
4	≥ 30.0	8	100	160																				
<p>SUBSECTION: PART: REVISION:</p>	<p>403.03.09 Leveling and Wedging, and Scratch Course. A) Leveling and Wedging. Replace the first sentence of the first paragraph with the following:</p> <p>Conform to the gradation requirements (control points) of AASHTO M 323 for base, binder, or surface as the Engineer directs.</p>																							
<p>SUBSECTION: PART: REVISION:</p>	<p>403.03.09 Leveling and Wedging, and Scratch Course. B) Scratch Course. Replace the second sentence of the first paragraph with the following:</p> <p>Conform to the gradation requirements (control points) of AASHTO M 323 for base, binder, or surface as the Engineer directs.</p>																							

**Supplemental Specifications to The Standard Specifications
for Road and Bridge Construction, 2008 Edition
(Effective with the April 23, 2010 Letting)**

SUBSECTION: REVISION:	407.01 DESCRIPTION. Replace the first sentence of the paragraph with the following: Construct a pavement wedge composed of a hot-mixed or warm-mixed asphalt mixture.
SUBSECTION: REVISION:	409.01 DESCRIPTION. Replace the first sentence of the paragraph with the following: Use reclaimed asphalt pavement (RAP) from Department projects or other approved sources in hot mix asphalt (HMA) or warm mix asphalt (WMA) provided mixture requirements are satisfied.
SUBSECTION: REVISION:	410.01 DESCRIPTION. Delete the second sentence of the paragraph.
SUBSECTION: REVISION:	410.03.01 Corrective Work. Replace the last sentence of the paragraph with the following: Provide a final surface comparable to the adjacent pavement that does not require corrective work in respect to texture, appearance, and skid resistance.
SUBSECTION: PART: NUMBER: REVISION:	410.03.02 Ride Quality. B) Requirements. 1) Category A. Replace the last sentence of the first paragraph with the following: At the Department's discretion, a pay deduction of \$1200 per 0.1-lane-mile section may be applied in lieu of corrective work.
SUBSECTION: PART: NUMBER: REVISION:	410.03.02 Ride Quality. B) Requirements. 2) Category B. Replace the second and third sentence of the first paragraph with the following: When the IRI is greater than 90 for a 0.1-mile section, perform corrective work, or remove and replace the pavement to achieve the specified IRI. At the Department's discretion, a pay deduction of \$750 per 0.1-lane-mile section may be applied in lieu of corrective work.
SUBSECTION: REVISION:	410.05 PAYMENT. Add the following sentence to the end of the first paragraph: The sum of the pay value adjustments for ride quality shall not exceed \$0 for the project as a whole.
SUBSECTION: REVISION:	413.05.02 CL3 SMA BASE 1.00D PG76-22. Insert the following sentence between the first and second sentence of the first paragraph: The Department will calculate the Lot Pay Adjustment using all possible incentives and disincentives but will not allow the overall pay value for a lot to exceed 1.00.

**Supplemental Specifications to The Standard Specifications
for Road and Bridge Construction, 2008 Edition
(Effective with the April 23, 2010 Letting)**

<p>SUBSECTION: TABLE: REVISION:</p>	<p>413.05.02 CL3 SMA BASE 1.00D PG 76-22. JOINT DENSITY TABLE Replace the joint density table with the following:</p> <table border="1" data-bbox="696 359 1143 625"> <thead> <tr> <th colspan="2">LANE DENSITY</th> </tr> <tr> <th>Pay Value</th> <th>Test Result (%)</th> </tr> </thead> <tbody> <tr> <td>1.05</td> <td>95.0-96.5</td> </tr> <tr> <td>1.00</td> <td>93.0-94.9</td> </tr> <tr> <td>0.95</td> <td>92.0-92.9 or 96.6-97.0</td> </tr> <tr> <td>0.90</td> <td>91.0-91.9 or 97.1-97.5</td> </tr> <tr> <td>⁽¹⁾</td> <td>< 91.0 or > 97.5</td> </tr> </tbody> </table>	LANE DENSITY		Pay Value	Test Result (%)	1.05	95.0-96.5	1.00	93.0-94.9	0.95	92.0-92.9 or 96.6-97.0	0.90	91.0-91.9 or 97.1-97.5	⁽¹⁾	< 91.0 or > 97.5										
LANE DENSITY																									
Pay Value	Test Result (%)																								
1.05	95.0-96.5																								
1.00	93.0-94.9																								
0.95	92.0-92.9 or 96.6-97.0																								
0.90	91.0-91.9 or 97.1-97.5																								
⁽¹⁾	< 91.0 or > 97.5																								
<p>SUBSECTION: REVISION:</p>	<p>413.05.03 CL3 SMA SURF 0.50A PG76-22 and CL3 SMA SURF 0.38A PG76-22. Insert the following sentence between the first and second sentence of the first paragraph:</p> <p>The Department will calculate the Lot Pay Adjustment using all possible incentives and disincentives but will not allow the overall pay value for a lot to exceed 1.00.</p>																								
<p>SUBSECTION: TABLE: REVISION:</p>	<p>413.05.03 CL3 SMA SURF 0.50A PG76-22 and CL3 SMA SURF 0.38A PG76-22. JOINT DENSITY TABLE Replace the joint density table with the following:</p> <table border="1" data-bbox="578 999 1261 1320"> <thead> <tr> <th colspan="3">DENSITY</th> </tr> <tr> <th>Pay Value</th> <th>Lane Density Test Result (%)</th> <th>Joint Density Test Result (%)</th> </tr> </thead> <tbody> <tr> <td>1.05</td> <td>95.0-96.5</td> <td>92.0-96.0</td> </tr> <tr> <td>1.00</td> <td>93.0-94.9</td> <td>90.0-91.9</td> </tr> <tr> <td>0.95</td> <td>92.0-92.9 or 96.6-97.0</td> <td>89.0-89.9 or 96.1-96.5</td> </tr> <tr> <td>0.90</td> <td>91.0-91.9 or 97.1-97.5</td> <td>88.0-88.9 or 96.6-97.0</td> </tr> <tr> <td>0.75</td> <td>----</td> <td>< 88.0 or > 97.0</td> </tr> <tr> <td>⁽¹⁾</td> <td>< 91.0 or > 97.5</td> <td>----</td> </tr> </tbody> </table>	DENSITY			Pay Value	Lane Density Test Result (%)	Joint Density Test Result (%)	1.05	95.0-96.5	92.0-96.0	1.00	93.0-94.9	90.0-91.9	0.95	92.0-92.9 or 96.6-97.0	89.0-89.9 or 96.1-96.5	0.90	91.0-91.9 or 97.1-97.5	88.0-88.9 or 96.6-97.0	0.75	----	< 88.0 or > 97.0	⁽¹⁾	< 91.0 or > 97.5	----
DENSITY																									
Pay Value	Lane Density Test Result (%)	Joint Density Test Result (%)																							
1.05	95.0-96.5	92.0-96.0																							
1.00	93.0-94.9	90.0-91.9																							
0.95	92.0-92.9 or 96.6-97.0	89.0-89.9 or 96.1-96.5																							
0.90	91.0-91.9 or 97.1-97.5	88.0-88.9 or 96.6-97.0																							
0.75	----	< 88.0 or > 97.0																							
⁽¹⁾	< 91.0 or > 97.5	----																							
<p>SUBSECTION: REVISION:</p>	<p>501.05.02 Ride Quality. Add the following sentence to the end of the first paragraph:</p> <p>The sum of the pay value adjustments for the ride quality shall not exceed \$0 for the project as a whole.</p>																								
<p>SUBSECTION: REVISION:</p>	<p>505.03.04 Detectable Warnings. Replace the first sentence with the following:</p> <p>Install detectable warning pavers at all sidewalk ramps and on all commercial entrances according to the Standard Drawings.</p>																								

**Supplemental Specifications to The Standard Specifications
for Road and Bridge Construction, 2008 Edition**
(Effective with the April 23, 2010 Letting)

<p>SUBSECTION: REVISION:</p>	<p>505.04.04 Detectable Warnings. Replace the paragraph with the following:</p> <p>The Department will measure the quantity in square feet. All retrofit applications for maintenance projects will require the removal of existing sidewalks to meet the requirements of the standard drawings applicable to the project. The cost associated with the removal of the existing sidewalk will be incidental to the detectable warnings bid item or incidental to the bid item for the construction of the concrete sidewalk unless otherwise noted.</p>						
<p>SUBSECTION: REVISION:</p>	<p>505.05 PAYMENT. Add the following to the bid item table:</p> <table border="0" style="width: 100%;"> <thead> <tr> <th style="text-align: left;"><u>Code</u></th> <th style="text-align: left;"><u>Pay Item</u></th> <th style="text-align: left;"><u>Pay Unit</u></th> </tr> </thead> <tbody> <tr> <td>23158ES505</td> <td>Detectable Warnings</td> <td>Square Foot</td> </tr> </tbody> </table>	<u>Code</u>	<u>Pay Item</u>	<u>Pay Unit</u>	23158ES505	Detectable Warnings	Square Foot
<u>Code</u>	<u>Pay Item</u>	<u>Pay Unit</u>					
23158ES505	Detectable Warnings	Square Foot					
<p>SUBSECTION: REVISION:</p>	<p>509.01 DESCRIPTION. Replace the second paragraph with the following:</p> <p>The Department may allow the use of similar units that conform to the National Cooperative Highway Research Program (NCHRP) 350 Test Level 3 (TL-3) requirements and the typical features depicted by the Standard Drawings. Obtain the Engineers approval prior to use. Ensure the barrier wall shape, length, material, drain slot dimensions and locations typical features are met and the reported maximum deflection is 3 feet or less from the NCHRP 350 TL-3 for Test 3 – 11 (pickup truck impacting at 60 mph at a 25-degree angle.)</p>						
<p>SUBSECTION: REVISION:</p>	<p>601.03.02 Concrete Producer Responsibilities. Add the following to the first paragraph:</p> <p>If a concrete plant becomes unqualified during a project and there are no other qualified plants in the region, the Department will provide qualified personnel to witness and ensure the producer follows the required specifications. The Department will assess the Contractor a \$100 per hour charge for this service.</p>						
<p>SUBSECTION: REVISION:</p>	<p>606.02.11 Coarse Aggregate. Replace with the following:</p> <p>Conform to Section 805, size No. 8 or 9-M.</p>						
<p>SUBSECTION: REVISION:</p>	<p>609.04.06 Joint Sealing. Replace Subsection 601.04 with the following:</p> <p>Subsection 606.04.08.</p>						
<p>SUBSECTION: REVISION:</p>	<p>609.05 Payment. Replace the Pay Unit for Joint Sealing with the following:</p> <p>See Subsection 606.05.</p>						
<p>SUBSECTION: REVISION:</p>	<p>701.03.06 Initial Backfill. Replace the first sentence of the last paragraph with the following:</p> <p>When the Contract specifies, perform quality control testing to verify compaction according to KM 64-512.</p>						

**Supplemental Specifications to The Standard Specifications
for Road and Bridge Construction, 2008 Edition**
(Effective with the April 23, 2010 Letting)

<p>SUBSECTION: REVISION:</p>	<p>701.03.08 Testing of Pipe. Replace and rename the subsection with the following:</p> <p>701.03.08 Inspection of Pipe. The engineer will visually inspect all pipe. The Department will require camera/video inspection on a minimum of 50 percent of the linear feet of all installed pipe structures. Conduct camera/video inspection according to KM 64-114. The pipe to be installed under pavement will be selected first. If the total linear feet of pipe under pavement is less than 50 percent of the linear feet of all pipe installed, the Engineer will randomly select installations from the remaining pipe structures on the project to provide for the minimum inspection requirement. The pipe will be selected in complete runs (junction-junction or headwall-headwall) until the total linear feet of pipe to be inspected is at least 50 percent of the total linear feet of all installed pipe on the project.</p> <p>Unless the Engineer directs otherwise, schedule the inspections no sooner than 30 days after completing the installation and completion of earthwork to within 1 foot of the finished subgrade. When final surfacing conflicts with the 30-day minimum, conduct the inspections prior to placement of the final surface. The contractor must ensure that all pipe are free and clear of any debris so that a complete inspection is possible.</p> <p>Notify the Engineer immediately if distresses or locations of improper installation are discovered. When camera testing shows distresses or improper installation in the installed pipe, the Engineer may require additional sections to be tested. Provide the video and report to the Engineer when testing is complete in accordance with KM 64-114.</p> <p>Pipes that exhibit distress or signs of improper installation may necessitate repair or removal as the Engineer directs. These signs include, but are not limited to: deflection, cracking, joint separation, sagging or other interior damage. If corrugated metal or thermoplastic pipes exceed the deflection and installation thresholds indicated in the table below, provide the Department with an evaluation of each location conducted by a Professional Engineer addressing the severity of the deflection, structural integrity, environmental conditions, design service life, and an evaluation of the factor of safety using Section 12, "Buried Structures and Tunnel Liners," of the AASHTO LRFD Bridge Design Specifications. Based on the evaluation, the Department may allow the pipe to remain in place at a reduced unit price as shown in the table below. Provide 5 business days for the Department to review the evaluation. When the pipe shows deflection of 10 percent or greater, remove and replace the pipe. When the camera/video or laser inspection results are called into question, the Department may require direct measurements or mandrel testing.</p> <p>The Cabinet may elect to conduct Quality Assurance verifications of any pipe inspections.</p>						
<p>SUBSECTION: REVISION:</p>	<p>701.04.07 Testing. Replace and rename the subsection with the following:</p> <p>701.04.07 Pipeline Video Inspection. The Department will measure the quantity in linear feet along the pipe invert of the structure inspected. When inspection above the specified 50 percent is performed due to a disagreement or suspicion of additional distresses and the Department is found in error, the Department will measure the quantity as Extra Work according to Subsection 104.03. However, if additional distresses or non-conformance is found, the Department will not measure the additional inspection for payment.</p>						
<p>SUBSECTION: REVISION:</p>	<p>701.05 PAYMENT. Add the following pay item to the list of pay items:</p> <table border="0" style="width: 100%;"> <tr> <td style="width: 30%;"><u>Code</u></td> <td style="width: 40%;"><u>Pay Item</u></td> <td style="width: 30%;"><u>Pay Unit</u></td> </tr> <tr> <td>23131ER701</td> <td>Pipeline Video Inspection</td> <td>Linear Foot</td> </tr> </table>	<u>Code</u>	<u>Pay Item</u>	<u>Pay Unit</u>	23131ER701	Pipeline Video Inspection	Linear Foot
<u>Code</u>	<u>Pay Item</u>	<u>Pay Unit</u>					
23131ER701	Pipeline Video Inspection	Linear Foot					

**Supplemental Specifications to The Standard Specifications
for Road and Bridge Construction, 2008 Edition**
(Effective with the April 23, 2010 Letting)

SUBSECTION: TABLE: REVISION:	<p>701.05 PAYMENT PIPE DEFLECTION DETERMINED BY CAMERA TESTING Replace this table with the following table and note:</p> <table border="1" style="margin-left: auto; margin-right: auto;"> <thead> <tr> <th colspan="2" style="text-align: center;">PIPE DEFLECTION</th> </tr> <tr> <th style="text-align: center;">Amount of Deflection (%)</th> <th style="text-align: center;">Payment</th> </tr> </thead> <tbody> <tr> <td style="text-align: center;">0.0 to 5.0</td> <td style="text-align: center;">100% of the Unit Bid Price</td> </tr> <tr> <td style="text-align: center;">5.1 to 9.9</td> <td style="text-align: center;">50% of the Unit Bid Price ⁽¹⁾</td> </tr> <tr> <td style="text-align: center;">10 or greater</td> <td style="text-align: center;">Remove and Replace</td> </tr> </tbody> </table> <p>⁽¹⁾ Provide Structural Analysis as indicated above. Based on the structural analysis, pipe may be allowed to remain in place at the reduced unit price.</p>	PIPE DEFLECTION		Amount of Deflection (%)	Payment	0.0 to 5.0	100% of the Unit Bid Price	5.1 to 9.9	50% of the Unit Bid Price ⁽¹⁾	10 or greater	Remove and Replace		
PIPE DEFLECTION													
Amount of Deflection (%)	Payment												
0.0 to 5.0	100% of the Unit Bid Price												
5.1 to 9.9	50% of the Unit Bid Price ⁽¹⁾												
10 or greater	Remove and Replace												
SUBSECTION: TABLE: REVISION:	<p>701.05 PAYMENT PIPE DEFLECTION DETERMINED BY MANDREL TESTING Delete this table.</p>												
SUBSECTION: REVISION:	<p>713.02.01 Paint. Replace with the following: Conform to Section 842 and Section 846.</p>												
SUBSECTION: REVISION:	<p>713.03 CONSTRUCTION. Replace the first sentence of the second paragraph with the following: On interstates and parkways, and other routes approved by the State Highway Engineer, install pavement striping that is 6 inches in width.</p>												
SUBSECTION: REVISION:	<p>713.03.03 Paint Application. Replace the second paragraph with the following table:</p> <table border="1" style="margin-left: auto; margin-right: auto;"> <thead> <tr> <th style="text-align: center;">Material</th> <th style="text-align: center;">Paint Application Rate</th> <th style="text-align: center;">Glass Beads Application Rate</th> </tr> </thead> <tbody> <tr> <td style="text-align: center;">4 inch waterborne paint</td> <td style="text-align: center;">Min. of 16.5 gallons/mile</td> <td style="text-align: center;">Min. of 6 pounds/gallon</td> </tr> <tr> <td style="text-align: center;">6 inch waterborne paint</td> <td style="text-align: center;">Min. of 24.8 gallons/mile</td> <td style="text-align: center;">Min. of 6 pounds/gallon</td> </tr> <tr> <td style="text-align: center;">6 inch durable waterborne paint</td> <td style="text-align: center;">Min. of 36 gallons/mile</td> <td style="text-align: center;">Min. of 6 pounds/gallon</td> </tr> </tbody> </table>	Material	Paint Application Rate	Glass Beads Application Rate	4 inch waterborne paint	Min. of 16.5 gallons/mile	Min. of 6 pounds/gallon	6 inch waterborne paint	Min. of 24.8 gallons/mile	Min. of 6 pounds/gallon	6 inch durable waterborne paint	Min. of 36 gallons/mile	Min. of 6 pounds/gallon
Material	Paint Application Rate	Glass Beads Application Rate											
4 inch waterborne paint	Min. of 16.5 gallons/mile	Min. of 6 pounds/gallon											
6 inch waterborne paint	Min. of 24.8 gallons/mile	Min. of 6 pounds/gallon											
6 inch durable waterborne paint	Min. of 36 gallons/mile	Min. of 6 pounds/gallon											
SUBSECTION: REVISION:	<p>713.03.04 Marking Removal. Replace the last sentence of the paragraph with the following: Vacuum all marking material and removal debris concurrently with the marking removal operation.</p>												
SUBSECTION: REVISION:	<p>713.05 PAYMENT. Insert the following codes and pay items below the Pavement Striping – Permanent Paint:</p> <table style="margin-left: auto; margin-right: auto;"> <thead> <tr> <th style="text-align: left;"><u>Code</u></th> <th style="text-align: left;"><u>Pay Item</u></th> <th style="text-align: left;"><u>Pay Unit</u></th> </tr> </thead> <tbody> <tr> <td>23159EN</td> <td>Durable Waterborne Marking – 6 IN W</td> <td>Linear Foot</td> </tr> <tr> <td>23160EN</td> <td>Durable Waterborne Marking – 6 IN Y</td> <td>Linear Foot</td> </tr> </tbody> </table>	<u>Code</u>	<u>Pay Item</u>	<u>Pay Unit</u>	23159EN	Durable Waterborne Marking – 6 IN W	Linear Foot	23160EN	Durable Waterborne Marking – 6 IN Y	Linear Foot			
<u>Code</u>	<u>Pay Item</u>	<u>Pay Unit</u>											
23159EN	Durable Waterborne Marking – 6 IN W	Linear Foot											
23160EN	Durable Waterborne Marking – 6 IN Y	Linear Foot											
SUBSECTION: REVISION:	<p>714.03 CONSTRUCTION. Insert the following paragraph at the end of the third paragraph: Use Type I Tape for markings on bridge decks, JPC pavement and JPC intersections. Thermoplastic should only be used for markings on asphalt pavement.</p>												

**Supplemental Specifications to The Standard Specifications
for Road and Bridge Construction, 2008 Edition
(Effective with the April 23, 2010 Letting)**

<p>SUBSECTION: REVISION:</p>	<p>714.03.07 Marking Removal. Replace the third sentence of the paragraph with the following: Vacuum all marking material and removal debris concurrently with the marking removal operation.</p>
<p>SUBSECTION: REVISION:</p>	<p>716.01 DESCRIPTION. Insert the following after the first sentence: Energize lighting as soon as it is fully functional and ready for inspection. Ensure that lighting remains operational until the Division of Traffic Operations has provided written acceptance of the electrical work.</p>
<p>SUBSECTION: REVISION:</p>	<p>716.02.01 Roadway Lighting Materials. Replace the third sentence of the paragraph with the following: Submit for material approval an electronic file of descriptive literature, drawings, and any requested design data.</p>
<p>SECTION: REVISION:</p>	<p>717 – THERMOPLASTIC INTERSECTION MARKINGS. Replace the section name with the following: INTERSECTION MARKINGS.</p>
<p>SUBSECTION: REVISION:</p>	<p>717.01 DESCRIPTION: Replace the paragraph with the following: Furnish and install thermoplastic or Type I tape intersection markings (Stop Bars, Crosswalks, Turn Arrows, etc.) Thermoplastic markings may be installed by either a machine applied, screed extrusion process or by applying preformed thermoplastic intersection marking material.</p>
<p>SUBSECTION: REVISION:</p>	<p>717.02 MATERIALS AND EQUIPMENT. Insert the following subsection: 717.02.06 Type I Tape. Conform to Section 836.</p>
<p>SUBSECTION: REVISION:</p>	<p>717.03.03 Application. Insert the following part to the subsection: B) Type I Tape Intersection Markings. Apply according to the manufacturer’s recommendations. Cut all tape at pavement joints when applied to concrete surfaces.</p>
<p>SUBSECTION: PART: REVISION:</p>	<p>717.03.05 Proving Period. A) Requirements. Insert the following to this section: 2) Type I Tape. During the proving period, ensure that the pavement marking material shows no signs of failure due to blistering, excessive cracking, bleeding, staining, discoloration, oil content of the pavement materials, drippings, chipping, spalling, poor adhesion to the pavement, loss of retroreflectivity, vehicular damage, and normal wear. Type I Tape is manufactured off site and warranted by the manufacturer to meet certain retroreflective requirements. As long as the material is adequately bonded to the surface and shows no signs of failure due to the other items listed in Subsection 714.03.06 A) 1), retroreflectivity readings will not be required. In the absence of readings, the Department will accept tape based on a nighttime visual observation.</p>

**Supplemental Specifications to The Standard Specifications
for Road and Bridge Construction, 2008 Edition
(Effective with the April 23, 2010 Letting)**

<p>SUBSECTION: REVISION:</p>	<p>717.03.06 Marking Removal. Replace the third sentence of the paragraph with the following: Vacuum all marking material and removal debris concurrently with the marking removal operation.</p>																																							
<p>SUBSECTION: REVISION:</p>	<p>717.05 PAYMENT. Insert the following bid item codes:</p> <table border="0" data-bbox="386 478 1453 869"> <thead> <tr> <th align="left"><u>Code</u></th> <th align="left"><u>Pay Unit</u></th> <th align="left"><u>Pay Item</u></th> </tr> </thead> <tbody> <tr> <td>06563</td> <td>Pave Marking – R/R X Bucks 16 IN</td> <td>Linear Foot</td> </tr> <tr> <td>20782NS714</td> <td>Pave Marking Thermo – Bike</td> <td>Each</td> </tr> <tr> <td>23251ES717, 23264ES717</td> <td>Pave Mark TY I Tape X-Walk, Size</td> <td>Linear Foot</td> </tr> <tr> <td>23252ES717, 23265ES717</td> <td>Pave Mark TY I Tape Stop Bar, Size</td> <td>Linear Foot</td> </tr> <tr> <td>23253ES717</td> <td>Pave Mark TY I Tape Cross Hatch</td> <td>Square Foot</td> </tr> <tr> <td>23254ES717</td> <td>Pave Mark TY I Tape Dotted Lane Extension</td> <td>Linear Foot</td> </tr> <tr> <td>23255ES717</td> <td>Pave Mark TY I Tape Arrow, Type</td> <td>Each</td> </tr> <tr> <td>23268ES717-23270ES717</td> <td></td> <td></td> </tr> <tr> <td>23256ES717</td> <td>Pave Mark TY I Tape- ONLY</td> <td>Each</td> </tr> <tr> <td>23257ES717</td> <td>Pave Mark TY I Tape- SCHOOL</td> <td>Each</td> </tr> <tr> <td>23266ES717</td> <td>Pave Mark TY 1 Tape R/R X Bucks-16 IN</td> <td>Linear Foot</td> </tr> <tr> <td>23267ES717</td> <td>Pave Mark TY 1 Tape-Bike</td> <td>Each</td> </tr> </tbody> </table>	<u>Code</u>	<u>Pay Unit</u>	<u>Pay Item</u>	06563	Pave Marking – R/R X Bucks 16 IN	Linear Foot	20782NS714	Pave Marking Thermo – Bike	Each	23251ES717, 23264ES717	Pave Mark TY I Tape X-Walk, Size	Linear Foot	23252ES717, 23265ES717	Pave Mark TY I Tape Stop Bar, Size	Linear Foot	23253ES717	Pave Mark TY I Tape Cross Hatch	Square Foot	23254ES717	Pave Mark TY I Tape Dotted Lane Extension	Linear Foot	23255ES717	Pave Mark TY I Tape Arrow, Type	Each	23268ES717-23270ES717			23256ES717	Pave Mark TY I Tape- ONLY	Each	23257ES717	Pave Mark TY I Tape- SCHOOL	Each	23266ES717	Pave Mark TY 1 Tape R/R X Bucks-16 IN	Linear Foot	23267ES717	Pave Mark TY 1 Tape-Bike	Each
<u>Code</u>	<u>Pay Unit</u>	<u>Pay Item</u>																																						
06563	Pave Marking – R/R X Bucks 16 IN	Linear Foot																																						
20782NS714	Pave Marking Thermo – Bike	Each																																						
23251ES717, 23264ES717	Pave Mark TY I Tape X-Walk, Size	Linear Foot																																						
23252ES717, 23265ES717	Pave Mark TY I Tape Stop Bar, Size	Linear Foot																																						
23253ES717	Pave Mark TY I Tape Cross Hatch	Square Foot																																						
23254ES717	Pave Mark TY I Tape Dotted Lane Extension	Linear Foot																																						
23255ES717	Pave Mark TY I Tape Arrow, Type	Each																																						
23268ES717-23270ES717																																								
23256ES717	Pave Mark TY I Tape- ONLY	Each																																						
23257ES717	Pave Mark TY I Tape- SCHOOL	Each																																						
23266ES717	Pave Mark TY 1 Tape R/R X Bucks-16 IN	Linear Foot																																						
23267ES717	Pave Mark TY 1 Tape-Bike	Each																																						
<p>SUBSECTION: REVISION:</p>	<p>805.01 GENERAL. Replace the second paragraph with the following: The Department’s List of Approved Materials includes the Aggregate Source List, the list of Class A and Class B Polish-Resistant Aggregate Sources, and the Concrete Restriction List.</p>																																							
<p>SUBSECTION: REVISION:</p>	<p>805.04 CONCRETE. Replace the “AASHTO T 160” reference in first sentence of the third paragraph with “KM 64-629”</p>																																							
<p>SUBSECTION: TABLE: PART: REVISION:</p>	<p>805.15 GRADATION ACCEPTANCE OF NON-SPECIFICATION COARSE AGGREGATE. AGGREGATE SIZE USE Cement Concrete Structures and Incidental Construction Replace “9-M for Waterproofing Overlays” with “8 or 9-M for Waterproofing Overlays”</p>																																							

Supplemental Specifications to The Standard Specifications for Road and Bridge Construction, 2008 Edition (Effective with the April 23, 2010 Letting)

SUBSECTION: 805.15 GRADATION ACCEPTANCE OF NON-SPECIFICATION COARSE AGGREGATE.
REVISION: Replace the "SIZES OF COARSE AGGREGATES" table in with the following:

SIZES OF COARSE AGGREGATES																				
Aggregate Size	Sieve	AMOUNTS FINER THAN EACH LABORATORY SIEVE (SQUARE OPENINGS) PERCENTAGE BY WEIGHT																		
		Nominal ⁽¹⁾ Maximum Aggregate Size	4 inch	3 1/2 inch	3 inch	2 1/2 inch	2 inch	1 1/2 inch	1 inch	3/4 inch	1/2 inch	3/8 inch	No. 4	No. 8	No. 16	No. 30	No. 100	No. 200		
1	3 1/2 inch	100	90-100			25-60		0-15				0-5								
2	2 1/2 inch					100		35-70		0-15		0-5								
23	2 inch				100			40-90		0-15		0-5								
3	2 inch					100		90-100		35-70		0-5								
357	2 inch					100		95-100		35-70		10-30								
4	1 1/2 inch							100		90-100		20-55		0-15						
467	1 1/2 inch							100		95-100		35-70		0-10						
5	1 inch							100		90-100		20-55		0-10						
57	1 inch							100		95-100		25-60		0-10						
610	1 inch							100		85-100		40-75		15-40						
67	3/4 inch							100		90-100		20-55		0-10						
68	3/4 inch							100		90-100		30-65		5-25						
710	3/4 inch							100		80-100		30-75		0-30						
78	1/2 inch							100		90-100		40-75		5-25						
8	3/8 inch							100		85-100		10-30		0-10						
9-M	3/8 inch							100		75-100		0-25		0-5						
10 ⁽²⁾	No. 4							100		85-100										
11 ⁽²⁾	No. 4							100		40-90		10-40								
DENSE GRADED AGGREGATE ⁽³⁾	3/4 inch							100		70-100		50-80		30-65						
CRUSHED STONE BASE ⁽⁴⁾	1 1/2 inch					100		90-100		60-95		30-70		15-55						

⁽¹⁾ Gradation performed by wet sieve KM 64-620 or AASHTO T 11/T 27.
⁽²⁾ Sizes shown for convenience and are not to be considered as coarse aggregates.
⁽³⁾ Nominal Maximum Size is the largest sieve on the gradation table for an aggregate size on which any material may be retained.
 Note: The Department will allow blending of same source/same type aggregate when precise procedures are used such as cold feed, belt, or equivalent and combining of sizes or types of aggregate using the weigh hopper at concrete plants or controlled feed belts at the pugmill to obtain designated sizes.

**Supplemental Specifications to The Standard Specifications
for Road and Bridge Construction, 2008 Edition**
(Effective with the April 23, 2010 Letting)

<p>SUBSECTION: REVISION:</p>	<p>805.16 SAMPLING AND TESTING. Replace the "AASHTO T 160" method with the "KM 64-629" method for the Concrete Beam Expansion Test.</p> <p>Replace the "ASTM D 3042" method with the "KM 64-625" method for Insoluble Residue.</p>									
<p>SUBSECTION: REVISION:</p>	<p>810.04.01 Coating Requirements. Replace the "Subsection 806.07" references with "Subsection 806.06"</p>									
<p>SUBSECTION: PART: REVISION:</p>	<p>810.06.01 Polyvinyl Chloride (PVC) Pipe. B) Culvert and Entrance Pipe. Replace the title with the following:</p> <p>B) Culvert Pipe, Storm Sewer, and Entrance Pipe.</p>									
<p>SUBSECTION: REVISION:</p>	<p>837.03 APPROVAL. Replace the last sentence with the following:</p> <p>The Department will sample and evaluate for approval each lot of thermoplastic material delivered for use per contract prior to installation of the thermoplastic material. Do not allow the installation of thermoplastic material until it has been approved by the Division of Materials. Allow the Department a minimum of 10 working days to evaluate and approve thermoplastic material.</p>									
<p>SUBSECTION: REVISION:</p>	<p>837.03.01 Composition. COMPOSITION Table: Replace</p> <table border="1" data-bbox="396 995 1295 1087"> <tr> <td>Lead Chromate</td> <td>0.0 max.</td> <td>4.0 min.</td> </tr> <tr> <td>with</td> <td></td> <td></td> </tr> <tr> <td>Heavy Metals Content</td> <td colspan="2">Comply with 40 CFR 261</td> </tr> </table>	Lead Chromate	0.0 max.	4.0 min.	with			Heavy Metals Content	Comply with 40 CFR 261	
Lead Chromate	0.0 max.	4.0 min.								
with										
Heavy Metals Content	Comply with 40 CFR 261									
<p>SECTION: REVISION:</p>	<p>DIVISION 800 MATERIAL DETAILS Add the following section in Division 800</p> <p align="center">SECTION 846 – DURABLE WATERBORNE PAINT</p> <p>846.01 DESCRIPTION. This section covers quick-drying durable waterborne pavement striping paint for permanent applications. The paint shall be ready-mixed, one-component, 100% acrylic waterborne striping paint suitable for application on such traffic-bearing surfaces as Portland cement concrete, bituminous cement concrete, asphalt, tar, and previously painted areas of these surfaces.</p> <p>846.02 Approval. Select materials that conform to the composition requirements below. Provide independent analysis data and certification for each formulation stating the total concentration of each heavy metal present, the test method used for each determination, and compliance to 40 CFR 261 for leachable heavy metals content. Submit initial samples for approval before beginning striping operations. The initial sample may be sent from the manufacture of the paint. The Department will randomly sample and evaluate the paint each week that the striping operations are in progress.</p> <p>The non-volatile portion of the vehicle shall be composed of a 100% acrylic polymer as determined by infrared spectral analysis. The acrylic resin used shall be a 100% cross-linking acrylic as evidenced by infrared peaks at wavelengths 1568, 1624, and 1672 cm-1 with intensities equal to those produced by an acrylic resin known to be 100% cross-linking.</p>									

**Supplemental Specifications to The Standard Specifications
for Road and Bridge Construction, 2008 Edition
(Effective with the April 23, 2010 Letting)**

PAINT COMPOSITION		
Property and Test Method	Yellow	White
Daytime Color (CIELAB) Spectrophotometer using illuminant D65 at 45° illumination and 0° viewing with a 2° observer	L* 81.76 a* 19.79 b* 89.89 Maximum allowable variation 2.0• E*	L* 93.51 a* -1.01 b* 0.70 Maximum allowable variation 2.0• E*
Nighttime Color (CIELAB) Spectrophotometer using illuminant A at 45° illumination and 0° viewing with a 2° observer	L* 86.90 a* 24.80 b* 95.45 Maximum allowable variation 2.0• E*	L* 93.45 a* -0.79 b* 0.43 Maximum allowable variation 2.0• E*
Heavy Metals Content	Comply with 40 CFR 261	Comply with 40 CFR 261
Titanium Dioxide ASTM D 4764	NA	10% by weight of pigment min.
VOC ASTM D 2369 and D 4017	1.25 lb/gal max.	1.25 lb/gal max.
Contrast Ratio (at 15 mils wft)	0.97	0.99

846.02.01 Manufacturers Certification. Provide a certification of analysis for each lot of traffic paint produced stating conformance to the requirements of this section. Report the formulation identification, traffic paint trade name, color, date of manufacturer, total quantity of lot produced, actual quantity of traffic paint represented, sampling method utilized to obtain the samples, and data for each sample tested to represent each lot produced.

846.03 ACCEPTANCE PROCEDURES FOR NON-SPECIFICATION DURABLE WATERBORNE PAVEMENT STRIPING PAINT. When non-specification paint is inadvertently incorporated into the work the Department will accept the material with a reduction in pay. The percentage deduction is cumulative based on its compositional properties, but will not exceed 60 percent. The Department will calculate the payment reduction on the unit bid price for the routes where the non-specification paint was used.

DURABLE WATERBORNE PAVEMENT STRIPING PAINT REDUCTION SCHEDULE						
Non-conforming Property	Resin	Color	Contrast	TiO₂	VOC	Heavy Metals Content
Reduction Rate	60%	10%	10%	10%	60%	60%

**STANDARD DRAWINGS THAT APPLY
KY 547 & KY 1120**

CURVE WIDENING AND SUPERELEVATION TRANSITIONS.....	RGS-001-06
MISCELLANEOUS STANDARDS PART 1	RGX-001-05
APPROACHES, ENTRANCES, AND MAIL BOX TURNOUT	RPM-110-05
TYPICAL INSTALLATIONS FOR SIDEWALK RAMPS	RPM-160-03
LANE CLOSURE TWO-LANE HIGHWAY CASE I.....	TTC-100-01
LANE CLOSURE TWO-LANE HIGHWAY CASE II.....	TTC-105-01
LANE CLOSURE MULTI-LANE HIGHWAY CASE I.....	TTC-115-01
SHOULDER CLOSURE.....	TTC-135-01
POST SPLICING DETAIL	TTD-110-01
PAVEMENT CONDITION WARNING SIGNS.....	TTD-125
MOBILE OPERATION FOR PAINT STRIPING CASE II.....	TTS-105-01

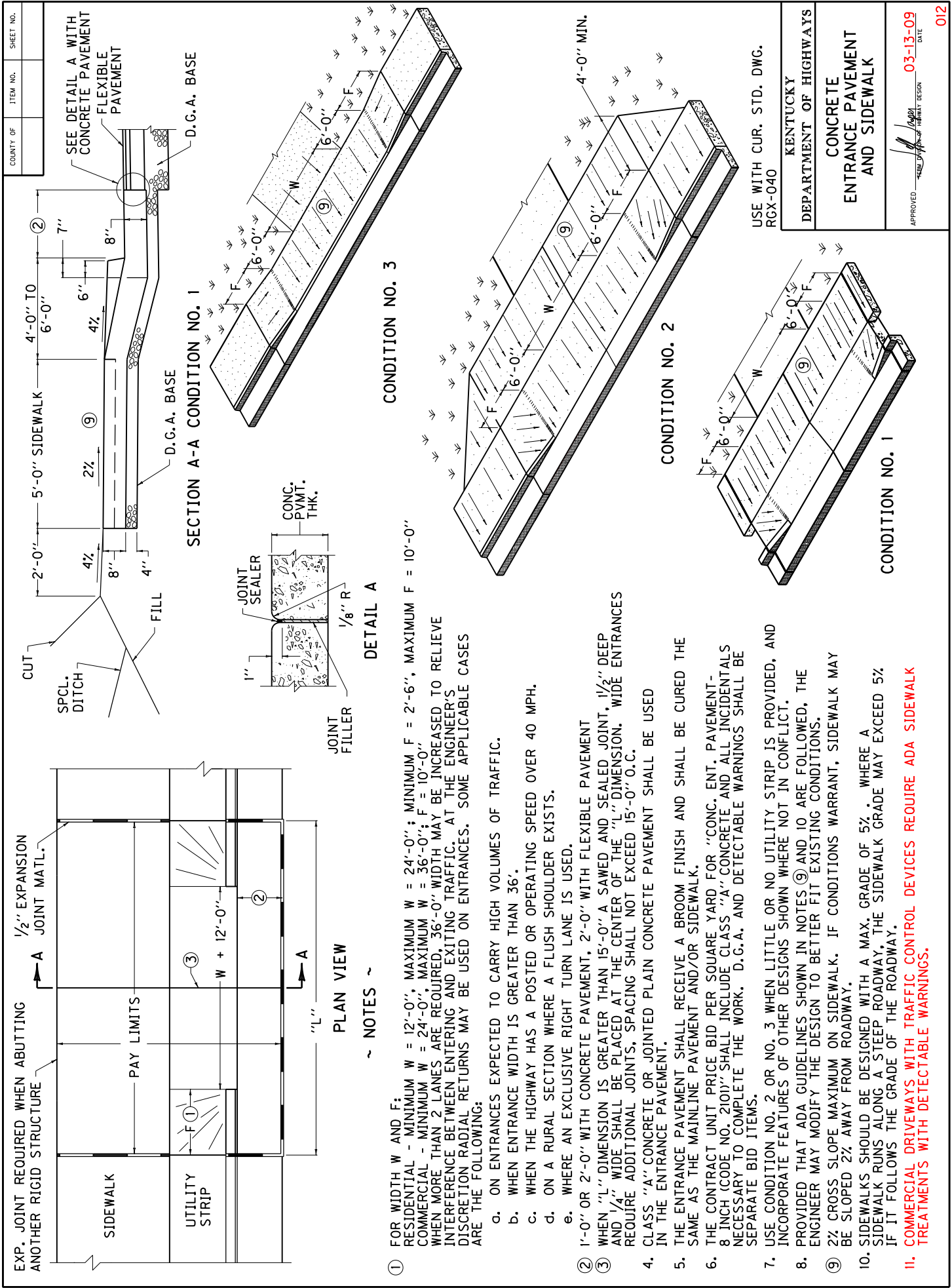

- ① FOR WIDTH W AND F:
RESIDENTIAL - MINIMUM W = 12'-0", MAXIMUM W = 24'-0"; MINIMUM F = 2'-6", MAXIMUM F = 10'-0"
COMMERCIAL - MINIMUM W = 24'-0", MAXIMUM W = 36'-0"; F = 10'-0"
WHEN MORE THAN 2 LANES ARE REQUIRED, 36'-0" WIDTH MAY BE INCREASED TO RELIEVE INTERFERENCE BETWEEN ENTERING AND EXITING TRAFFIC. AT THE ENGINEER'S DISCRETION RADIAL RETURNS MAY BE USED ON ENTRANCES. SOME APPLICABLE CASES ARE THE FOLLOWING:
 - a. ON ENTRANCES EXPECTED TO CARRY HIGH VOLUMES OF TRAFFIC.
 - b. WHEN ENTRANCE WIDTH IS GREATER THAN 36'.
 - c. WHEN THE HIGHWAY HAS A POSTED OR OPERATING SPEED OVER 40 MPH.
 - d. ON A RURAL SECTION WHERE A FLUSH SHOULDER EXISTS.
 - e. WHERE AN EXCLUSIVE RIGHT TURN LANE IS USED.
 - ② 1'-0" OR 2'-0" WITH CONCRETE PAVEMENT, 2'-0" WITH FLEXIBLE PAVEMENT
 - ③ WHEN "L" DIMENSION IS GREATER THAN 15'-0" A SAWED AND SEALED JOINT, 1/2" DEEP AND 1/4" WIDE SHALL BE PLACED AT THE CENTER OF THE "L" DIMENSION. WIDE ENTRANCES REQUIRE ADDITIONAL JOINTS, SPACING SHALL NOT EXCEED 15'-0" O.C.
 4. CLASS "A" CONCRETE OR JOINTED PLAIN CONCRETE PAVEMENT SHALL BE USED IN THE ENTRANCE PAVEMENT.
 5. THE ENTRANCE PAVEMENT SHALL RECEIVE A BROOM FINISH AND SHALL BE CURED THE SAME AS THE MAINLINE PAVEMENT AND/OR SIDEWALK.
 6. THE CONTRACT UNIT PRICE BID PER SQUARE YARD FOR "CONC. ENT. PAVEMENT- 8 INCH (CODE NO. 210)" SHALL INCLUDE CLASS "A" CONCRETE AND ALL INCIDENTALS NECESSARY TO COMPLETE THE WORK. D.G.A. AND DETECTABLE WARNINGS SHALL BE SEPARATE BID ITEMS.
 7. USE CONDITION NO. 2 OR NO. 3 WHEN LITTLE OR NO UTILITY STRIP IS PROVIDED, AND INCORPORATE FEATURES OF OTHER DESIGNS SHOWN WHERE NOT IN CONFLICT.
 8. PROVIDED THAT ADA GUIDELINES SHOWN IN NOTES ⑨ AND 10 ARE FOLLOWED, THE ENGINEER MAY MODIFY THE DESIGN TO BETTER FIT EXISTING CONDITIONS.
 - ⑨ 2% CROSS SLOPE MAXIMUM ON SIDEWALK. IF CONDITIONS WARRANT, SIDEWALK MAY BE SLOPED 2% AWAY FROM ROADWAY.
 10. SIDEWALKS SHOULD BE DESIGNED WITH A MAX. GRADE OF 5%. WHERE A SIDEWALK RUNS ALONG A STEEP ROADWAY, THE SIDEWALK GRADE MAY EXCEED 5% IF IT FOLLOWS THE GRADE OF THE ROADWAY.
- 11. COMMERCIAL DRIVEWAYS WITH TRAFFIC CONTROL DEVICES REQUIRE ADA SIDEWALK TREATMENTS WITH DETECTABLE WARNINGS.**

COUNTY OF	ITEM NO.	SHEET NO.

~ NOTES ~

- ① FOR WIDTH W: COMMERCIAL - MINIMUM W = 24'-0", MAXIMUM W = 36'-0" WHEN MORE THAN 2 LANES ARE REQUIRED, 36'-0" WIDTH MAY BE INCREASED TO RELIEVE INTERFERENCE BETWEEN ENTERING AND EXITING TRAFFIC. AT THE ENGINEER'S DISCRETION RADIAL RETURNS MAY BE USED ON ENTRANCES. SOME APPLICABLE CASES ARE THE FOLLOWING:
 - a. ON ENTRANCES EXPECTED TO CARRY HIGH VOLUMES OF TRAFFIC.
 - b. WHEN ENTRANCE WIDTH IS GREATER THAN 36'.
 - c. WHEN THE HIGHWAY HAS A POSTED OR OPERATING SPEED OVER 40 MPH.
 - d. ON A RURAL SECTION WHERE A FLUSH SHOULDER EXISTS.
 - e. WHERE AN EXCLUSIVE RIGHT TURN LANE IS USED.
- ② 1'-0" OR 2'-0" WITH CONCRETE PAVEMENT, 2'-0" WITH FLEXIBLE PAVEMENT.
- ③ WHEN "L" DIMENSION IS GREATER THAN 15'-0" A SAWED AND SEALED JOINT, 1/2" DEEP AND 1/4" WIDE SHALL BE PLACED AT THE CENTER OF THE "L" DIMENSION. WIDE ENTRANCES REQUIRE ADDITIONAL JOINTS, SPACING SHALL NOT EXCEED 15'-0" O.C. CLASS "A" CONCRETE OR JOINTED PLAIN CONCRETE PAVEMENT SHALL BE USED IN THE ENTRANCE PAVEMENT.
5. THE ENTRANCE PAVEMENT SHALL RECEIVE A BROOM FINISH AND SHALL BE CURED THE SAME AS THE MAINLINE PAVEMENT AND/OR SIDEWALK.
6. THE CONTRACT UNIT PRICE BID PER SQUARE YARD FOR "CONC. ENT. PAVEMENT-8 INCH (CODE NO. 2101)" SHALL INCLUDE CLASS "A" CONCRETE AND ALL INCIDENTALS NECESSARY TO COMPLETE THE WORK. D.G.A. AND DETECTABLE WARNINGS SHALL BE SEPARATE BID ITEMS.
7. PROVIDING THAT ADA GUIDELINES SHOWN IN NOTE ⑧ AND 9 ARE FOLLOWED, THE ENGINEER MAY MODIFY THE DESIGN TO BETTER FIT EXISTING CONDITIONS.
- ⑧ 2% CROSS SLOPE MAXIMUM ON SIDEWALK.
9. SIDEWALKS SHOULD BE DESIGNED WITH A MAX. GRADE OF FIVE PERCENT. WHERE A SIDEWALK RUNS ALONG A STEEP ROADWAY, THE SIDEWALK GRADE MAY EXCEED FIVE PERCENT IF IT FOLLOWS THE GRADE OF THE ROADWAY.
- ⑩ COMMERCIAL DRIVEWAYS WITH TRAFFIC CONTROL DEVICES REQUIRE ADA SIDEWALK TREATMENTS WITH DETECTABLE WARNINGS.

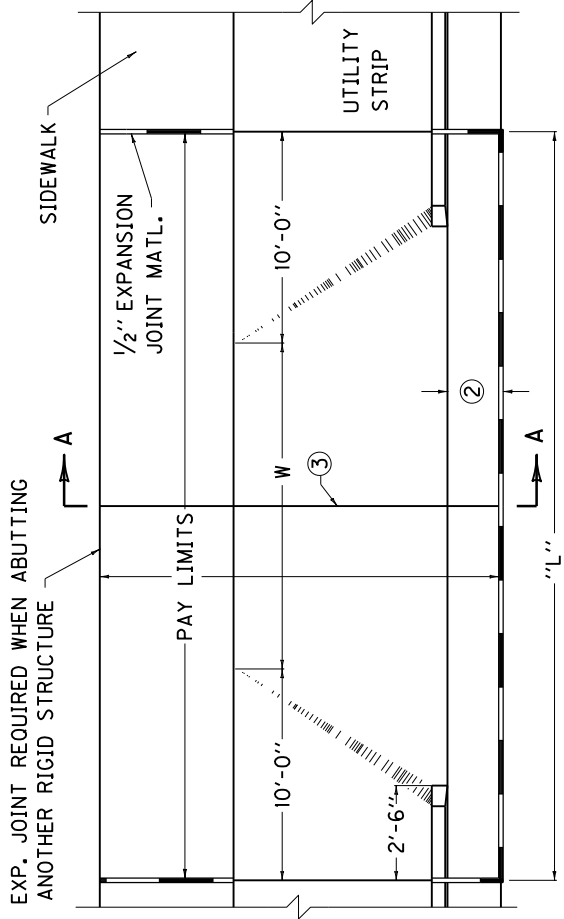

PLAN VIEW

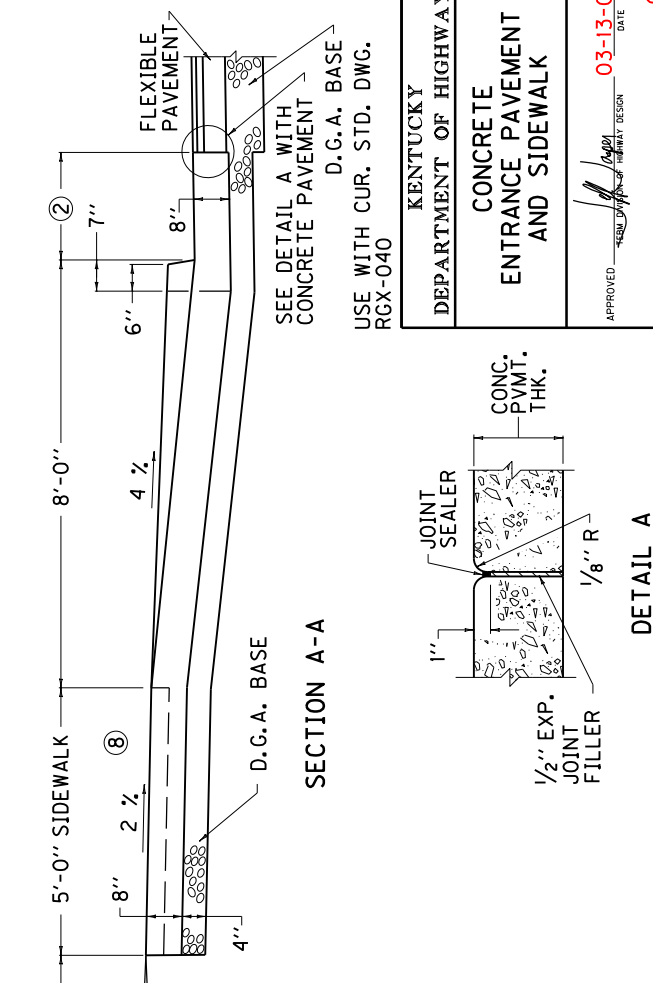

SECTION A-A

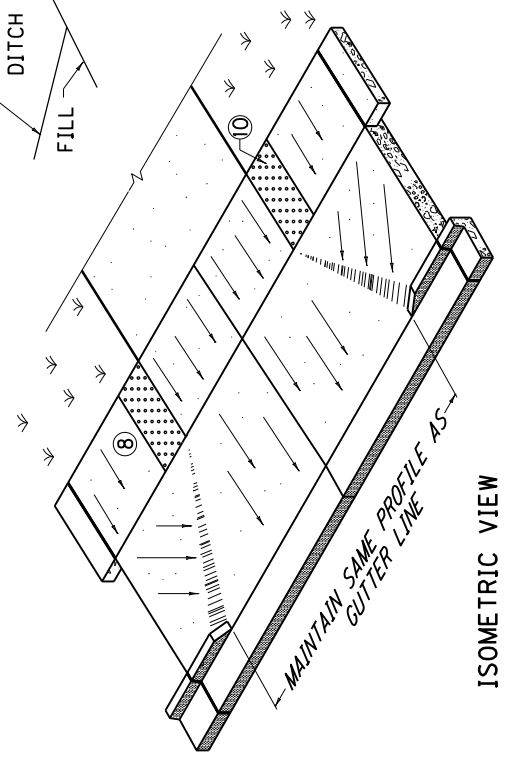

ISOMETRIC VIEW

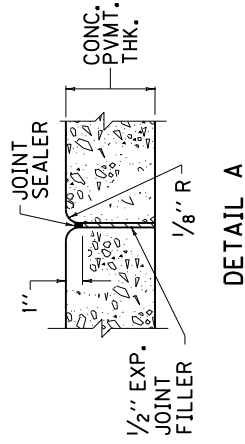

DETAIL A

KENTUCKY
DEPARTMENT OF HIGHWAYS

CONCRETE
ENTRANCE PAVEMENT
AND SIDEWALK

APPROVED: *[Signature]* DATE: 03-13-05
DESIGNED BY: *[Signature]* DATE: 01

SEE DETAIL A WITH
CONCRETE PAVEMENT
D.G.A. BASE
USE WITH CUR. STD. DWG.
RCX-040

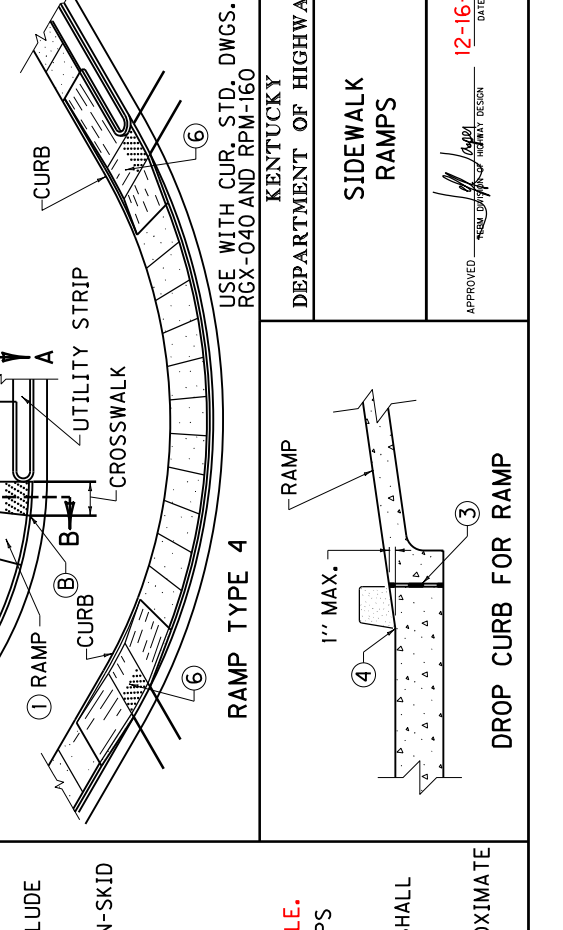
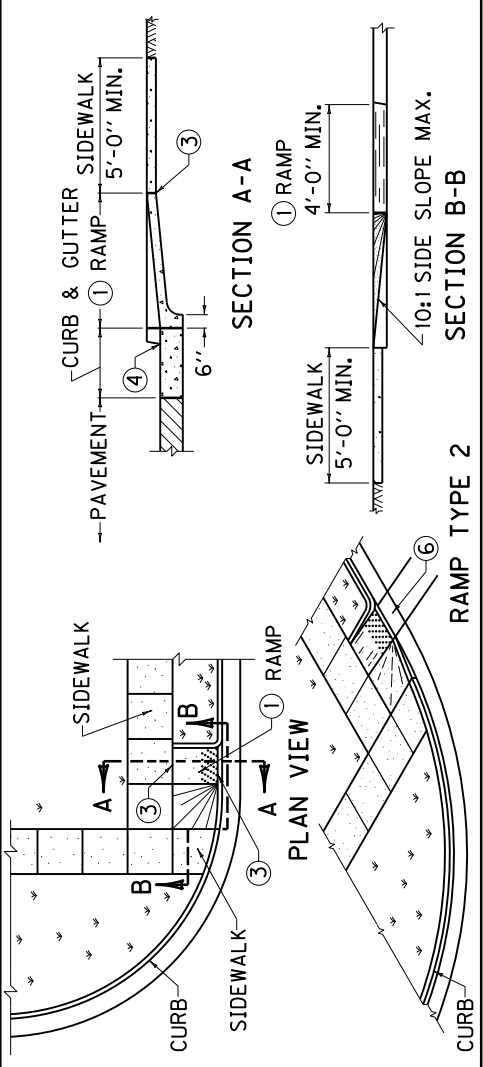
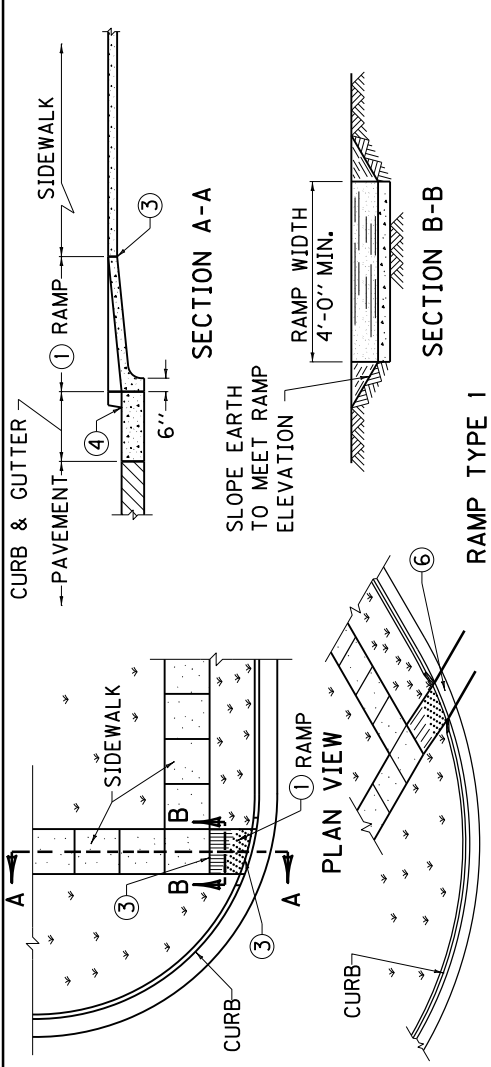
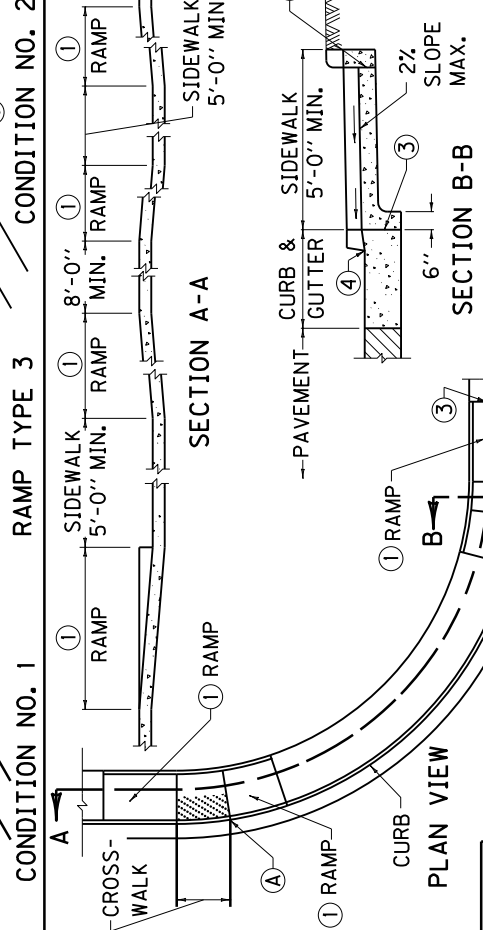
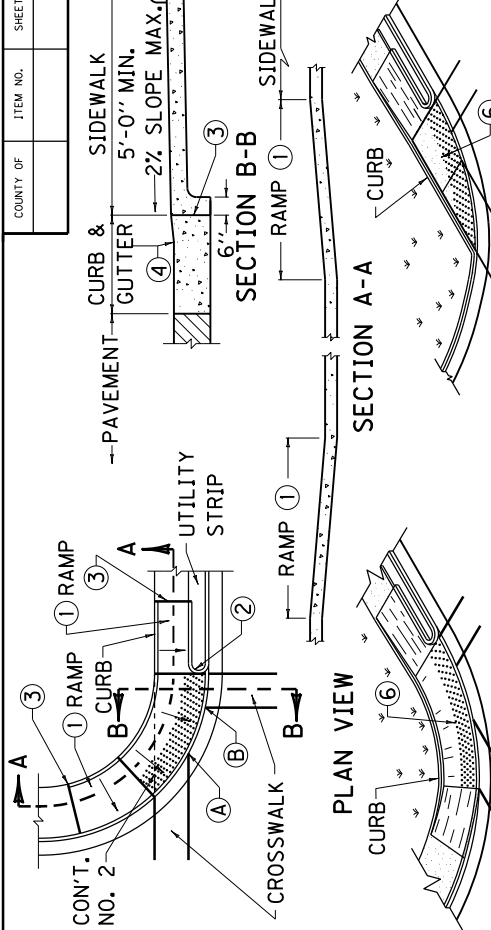

NOTES

RAMPS SHALL BE PAID PER SQ. YARD OF 4" CONC. SIDEWALK AND THE UNIT PRICE SHALL INCLUDE ALL MATERIALS, FORMS, CURB BEHIND RAMP AND LANDING, AND INCIDENTALS NECESSARY FOR CONSTRUCTION.

THE RAMP SHALL BE CONSTRUCTED OF CLASS "A" CONCRETE. A BROOM FINISH OR EQUAL NON-SKID FINISH IS REQUIRED. **DETECTABLE WARNINGS SHALL BE A SEPARATE BID ITEM.**

THE NORMAL GUTTER LINE SHALL BE MAINTAINED THROUGH THE AREA OF THE RAMP. RAMPS SHOULD BE LOCATED WITHIN MARKED LIMITS OF CROSSWALKS.

USE RAMP TYPE 3 WHEN POINT A TO B IS LESS THAN 20 FEET.

USE RAMP TYPE 4 WHEN POINT A TO B IS 20 FEET OR MORE.

① CURB RAMP GRADE SHALL NOT EXCEED 12:1, CROSS SLOPE SHALL NOT EXCEED 2%.

ON RETROFIT CURB RAMPS, GRADES OF 12.5% FOR 2'-0" OR 10% FOR 5'-0" ARE PERMISSIBLE.

② CURB RETURN REQUIRED WHEN UTILITY STRIP IS 4 FEET OR GREATER. FOR UTILITY STRIPS LESS THAN 4 FEET, THE AREA IS TO BE SURFACED WITH SIDEWALK WITHIN THE RAMP.

③ 1/2" EXPANSION JOINT AT BACK OF CURB LINE AND AT SIDEWALK LINE.

④ NO BUMP PERMITTED. SAME SLOPE AS RAMP AND NOT TO EXCEED 1" IN HEIGHT. RAMPS SHALL BE CONSTRUCTED SO THAT WATER WILL NOT ACCUMULATE ON WALKING SURFACES.

5. ALL SIDEWALK RAMPS REQUIRE DETECTABLE WARNINGS.

⑥ LANDINGS WILL PROVIDE A LEVEL AREA (LESS THAN 2% GRADE OR CROSS SLOPE) AT APPROXIMATE STREET ELEVATION. A 4 FOOT SQUARE LEVEL LANDING IS THE REQUIRED MINIMUM.

COUNTY OF	ITEM NO.	SHEET NO.

USE WITH CUR. STD. DWGS.
RGX-040 AND RPM-160

KENTUCKY
DEPARTMENT OF HIGHWAYS

SIDEWALK
RAMPS

APPROVED _____
DATE 12-16-18

COUNTY OF	ITEM NO.	SHEET NO.

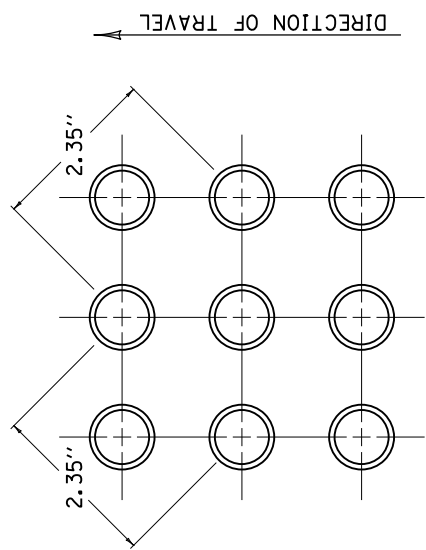

SQUARE PATTERN (PARALLEL ALIGNMENT)

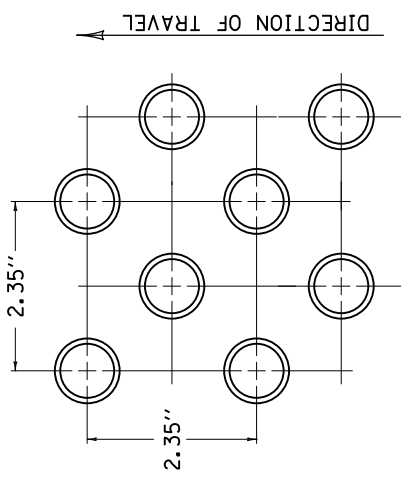

SQUARE PATTERN (DIAGONAL ALIGNMENT)

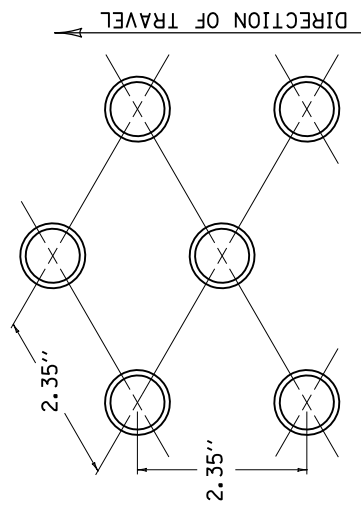

TRIANGULAR PATTERN

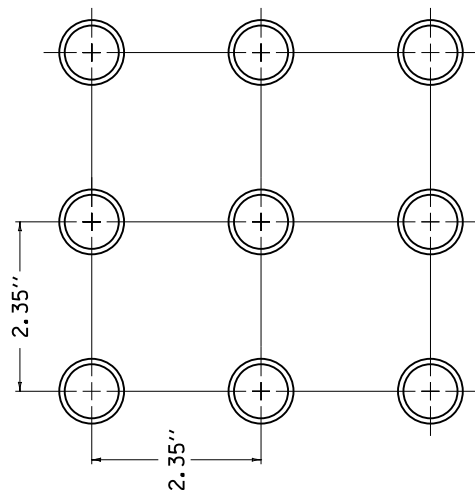

SQUARE PATTERN

NOTES

- BID ITEM AND UNIT TO BID.
 DETECTABLE WARNINGS - SQ. FT.
- 1. LANDINGS WILL PROVIDE A LEVEL AREA (LESS THAN 2% GRADE OR CROSS SLOPE) AT APPROXIMATE STREET ELEVATION. A 4 FOOT SQUARE LEVEL LANDING IS THE REQUIRED MINIMUM.
- 2. ALL SIDEWALK RAMPS REQUIRE DETECTABLE WARNINGS.
- 3. **COMMERCIAL DRIVEWAYS WITH TRAFFIC CONTROL DEVICES REQUIRE ADA SIDEWALK TREATMENTS WITH DETECTABLE WARNINGS.**
- 4. PAVERS SHALL BE CONCRETE WITH A MINIMUM THICKNESS OF 2".
- 5. PAVERS SHALL BE A COLOR HOMOGENOUS THROUGHOUT THE PAVER, THAT COLOR SHALL CONTRAST VISUALLY WITH THE ADJOINING SURFACES, EITHER LIGHT-ON-DARK OR DARK-ON-LIGHT. THE DEPARTMENT WILL ALLOW EITHER YELLOW OR RED AS COLORS.
- ⑥ PAVERS TO BE SET IN MORTAR.
- ⑦ DETECTABLE WARNING SURFACE BEGINS AT BACK OF CURB.

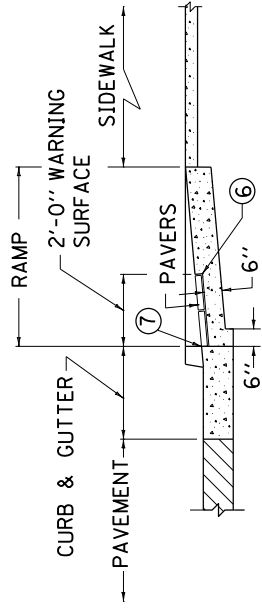

TYPICAL DETECTABLE WARNING INSTALLATION

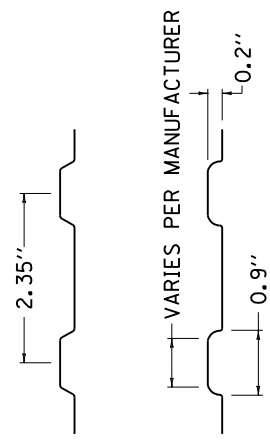

DETECTABLE WARNINGS PROFILE

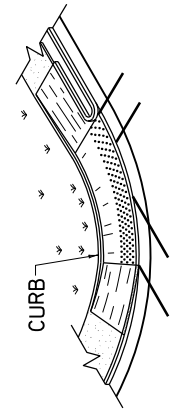

TYPICAL PLACEMENT PARALLEL CURB RAMPS

USE WITH CUR. STD. DWGS.
 RPM-160 AND RPM-170

KENTUCKY DEPARTMENT OF HIGHWAYS
DETECTABLE WARNINGS

APPROVED	DATE
<i>[Signature]</i>	03-13-09

PART III

EMPLOYMENT, WAGE AND RECORD REQUIREMENTS

**TRANSPORTATION CABINET
DEPARTMENT OF HIGHWAYS**

**LABOR AND WAGE REQUIREMENTS
APPLICABLE TO OTHER THAN FEDERAL-AID SYSTEM PROJECTS**

- I. Application
- II. Nondiscrimination of Employees (KRS 344)
- III. Payment of Predetermined Minimum Wages
- IV. Statements and Payrolls

I. APPLICATION

1. These contract provisions shall apply to all work performed on the contract by the contractor with his own organization and with the assistance of workmen under his immediate superintendence and to all work performed on the contract by piecework, station work or by subcontract. The contractor's organization shall be construed to include only workmen employed and paid directly by the contractor and equipment owned or rented by him, with or without operators.

2. The contractor shall insert in each of his subcontracts all of the stipulations contained in these Required Provisions and such other stipulations as may be required.

3. A breach of any of the stipulations contained in these Required Provisions may be grounds for termination of the contract.

II. NONDISCRIMINATION OF EMPLOYEES

**AN ACT OF THE KENTUCKY
GENERAL ASSEMBLY TO PREVENT
DISCRIMINATION IN EMPLOYMENT
KRS CHAPTER 344
EFFECTIVE JUNE 16, 1972**

The contract on this project, in accordance with KRS Chapter 344, provides that during the performance of this contract, the contractor agrees as follows:

1. The contractor shall not fail or refuse to hire, or shall not discharge any individual, or otherwise discriminate against an individual with respect to his compensation, terms, conditions, or privileges of employment, because of such individual's race, color, religion, national origin, sex, disability or age (between forty and seventy); or limit, segregate, or classify his employees in any way which would deprive or tend to deprive an individual of employment opportunities or otherwise adversely affect his status as an employee, because of such individual's race, color, religion, national origin, sex, disability or age (between forty and seventy). The contractor agrees to post in conspicuous places, available to employees and applicants for employment, notices to be provided setting forth the provisions of this nondiscrimination clause.

2. The contractor shall not print or publish or cause to be printed or published a notice or advertisement relating to employment by such an employer or membership in or any classification or referral for employment by the employment agency, indicating any preference, limitation, specification, or discrimination, based on race, color, religion, national origin, sex, disability or age (between forty and seventy), except that such notice or advertisement may indicate a preference, limitation, or specification based on religion, or national origin when religion, or national origin is a bona fide occupational qualification for employment.

3. If the contractor is in control of apprenticeship or other training or retraining, including on-the-job training programs, he shall not discriminate against an individual

because of his race, color, religion, national origin, sex, disability or age (between forty and seventy), in admission to, or employment in any program established to provide apprenticeship or other training.

4. The contractor will send to each labor union or representative of workers with which he has a collective bargaining agreement or other contract or understanding, a notice to be provided advising the said labor union or workers' representative of the contractor's commitments under this section, and shall post copies of the notice in conspicuous places available to employees and applicants for employment. The contractor will take such action with respect to any subcontract or purchase order as the administering agency may direct as a means of enforcing such provisions, including sanctions for non-compliance.

III. PAYMENT OF PREDETERMINED MINIMUM WAGES

1. These special provisions are supplemented elsewhere in the contract by special provisions which set forth certain predetermined minimum wage rates. The contractor shall pay not less than those rates.

2. The minimum wage determination schedule shall be posted by the contractor, in a manner prescribed by the Department of Highways, at the site of the work in prominent places where it can be easily seen by the workers.

IV. STATEMENTS AND PAYROLLS

1. All contractors and subcontractors affected by the terms of KRS 337.505 to 337.550 shall keep full and accurate payroll records covering all disbursements of wages to their employees to whom they are required to pay not less than the prevailing rate of wages. Payrolls and basic records relating thereto will be maintained during the course of the work and preserved for a period of one (1) year from the date of completion of this contract.

2. The payroll records shall contain the name, address and social security number of each employee, his correct classification, rate of pay, daily and weekly number of hours worked, itemized deductions made and actual wages paid.

3. The contractor shall make his daily records available at the project site for inspection by the State Department of Highways contracting office or his authorized representative.

Periodic investigations shall be conducted as required to assure compliance with the labor provisions of the contract. Interrogation of employees and officials of the contractor shall be permitted during working hours.

Aggrieved workers, Highway Managers, Assistant District Engineers, Resident Engineers and Project Engineers shall report all complaints and violations to the Division of Contract Procurement.

The contractor shall be notified in writing of apparent violations. The contractor may correct the reported violations and notify the Department of Highways of the action taken or may request an informal hearing. The request for hearing shall be in writing within ten (10) days after receipt of the notice of the reported violation. The contractor may submit

records and information which will aid in determining the true facts relating to the reported violations.

Any person or organization aggrieved by the action taken or the findings established as a result of an informal hearing by the Division of Contract Procurement may request a formal hearing.

4. The wages of labor shall be paid in legal tender of the United States, except that this condition will be considered satisfied if payment is made by a negotiable check, on a solvent bank, which may be cashed readily by the employee in the local community for the full amount, without discount or collection charges of any kind. Where checks are used for payments, the contractor shall make all necessary arrangements for them to be cashed and shall give information regarding such arrangements.

5. No fee of any kind shall be asked or accepted by the contractor or any of his agents from any person as a condition of employment on the project.

6. No laborers shall be charged for any tools used in performing their respective duties except for reasonably avoidable loss or damage thereto.

7. Every employee on the work covered by this contract shall be permitted to lodge, board, and trade where and with whom he elects and neither the contractor nor his agents, nor his employees shall directly or indirectly require as a condition of employment that an employee shall lodge, board or trade at a particular place or with a particular person.

8. Every employee on the project covered by this contract shall be an employee of either the prime contractor or an approved subcontractor.

9. No charge shall be made for any transportation furnished by the contractor or his agents to any person employed on the work.

10. No individual shall be employed as a laborer or mechanic on this contract except on a wage basis, but this shall not be construed to prohibit the rental of teams, trucks or other equipment from individuals.

No Covered employee may be employed on the work except in accordance with the classification set forth in the schedule mentioned above; provided, however, that in the event additional classifications are required, application shall be made by the contractor to the Department of Highways and (1) the Department shall request appropriate classifications and rates from the proper agency, or (2) if there is urgent need for additional classification to avoid undue delay in the work, the contractor may employ such workmen at rates deemed comparable to rates established for similar classifications provided he has made written application through the Department of Highways, addressed to the proper agency, for the supplemental rates. The contractor shall retroactively adjust, upon receipt of the supplemental rates schedule, the wages of any employee paid less than the established rate and may adjust the wages of any employee overpaid.

11. No contractor or subcontractor contracting for any part of the contract work which may require or involve the employment of laborers or mechanics shall require or permit any laborer or mechanic in any work-week in which he is employed on such work, to work in excess of eight hours in any calendar day or in excess of forty hours in such work-week unless such laborer or mechanic receives compensation at a rate not less than one and one half times his basic rate of pay for all hours worked in excess of eight hours in any calendar day or in excess of forty hours in such work-week. A laborer, workman or mechanic and an employer may enter into a written agreement or a collective bargaining agreement to work more than eight (8) hours a calendar day but not more than ten (10) hours a calendar day for the straight time hourly rate. This agreement shall be in writing and shall be executed prior to the employee working in excess of eight (8) hours, but not more than ten (10) hours, in any one (1) calendar day.

12. Payments to the contractor may be suspended or withheld due to failure of the contractor to pay any laborer or

mechanic employed or working on the site of the work, all or part of the wages required under the terms of the contract. The Department may suspend or withhold payments only after the contractor has been given written notice of the alleged violation and the contractor has failed to comply with the wage determination of the Department of Highways.

13. Contractors and subcontractors shall comply with the sections of Kentucky Revised Statutes, Chapter 337 relating to contracts for Public Works.

Revised 2-16-95

EXECUTIVE BRANCH CODE OF ETHICS

In the 1992 regular legislative session, the General Assembly passed and Governor Brereton Jones signed Senate Bill 63 (codified as KRS 11A), the Executive Branch Code of Ethics, which states, in part:

KRS 11A.040 (6) provides:

No present or former public servant shall, within six (6) months of following termination of his office or employment, accept employment, compensation or other economic benefit from any person or business that contracts or does business with the state in matters in which he was directly involved during his tenure. This provision shall not prohibit an individual from returning to the same business, firm, occupation, or profession in which he was involved prior to taking office or beginning his term of employment, provided that, for a period of six (6) months, he personally refrains from working on any matter in which he was directly involved in state government. This subsection shall not prohibit the performance of ministerial functions, including, but not limited to, filing tax returns, filing applications for permits or licenses, or filing incorporation papers.

KRS 11A.040 (8) states:

A former public servant shall not represent a person in a matter before a state agency in which the former public servant was directly involved, for a period of one (1) year after the latter of:

- a) The date of leaving office or termination of employment; or
- b) The date the term of office expires to which the public servant was elected.

This law is intended to promote public confidence in the integrity of state government and to declare as public policy the idea that state employees should view their work as a public trust and not as a way to obtain private benefits.

If you have worked for the executive branch of state government within the past six months, you may be subject to the law's prohibitions. The law's applicability may be different if you hold elected office or are contemplating representation of another before a state agency.

Also, if you are affiliated with a firm which does business with the state and which employs former state executive-branch employees, you should be aware that the law may apply to them.

In case of doubt, the law permits you to request an advisory opinion from the Executive Branch Ethics Commission, Room 136, Capitol Building, 700 Capitol Avenue, Frankfort, Kentucky 40601; telephone (502) 564-7954.

Kentucky Equal Employment Opportunity Act of 1978

The requirements of the Kentucky Equal Employment Opportunity Act of 1978 (KRS 45.560-45.640) shall apply to this Contract. The apparent low Bidder will be required to submit EEO forms to the Division of Construction Procurement, which will then forward to the Finance and Administration Cabinet for review and approval. No award will become effective until all forms are submitted and EEO/CC has certified compliance. The required EEO forms are as follows:

- EEO-1: Employer Information Report
- Affidavit of Intent to Comply
- Employee Data Sheet
- Subcontractor Report

These forms are available on the Finance and Administration's web page under ***Vendor Information, Standard Attachments and General Terms*** at the following address:
<https://www.eProcurement.ky.gov>.

Bidders currently certified as being in compliance by the Finance and Administration Cabinet may submit a copy of their approval letter in lieu of the referenced EEO forms.

For questions or assistance please contact the Finance and Administration Cabinet by email at **finance.contractcompliance@ky.gov** or by phone at 502-564-2874.

**TRANSPORTATION CABINET
DIVISION OF CONSTRUCTION PROCUREMENT
COMPLIANCE SECTION
PROJECT WAGE RATES**

	HIGHWAY BASIC HOURLY RATES	FRINGE BENEFIT PAYMENTS COMBINED
--	---	---

CRAFTS:

Boone, Campbell, Kenton and Pendleton Counties:

Bricklayers.	26.12	9.73
Carpenters and Piledrivermen....	27.05	9.69
Divers.....	40.58	9.69
Millwrights	27.55	15.39
Cement Masons/ Concrete Finisher.....	25.75	8.60
Electricians	26.11	13.32
Sound & Communication:		
Technician.....	20.45	6.95
Ironworkers:		
Reinforcing: Up to and including 30- mile radius of Hamilton County, Ohio Courthouse		
....	26.20	16.70
Beyond 30- mile radius of Hamilton County, Ohio Courthouse		
.....	26.45	16.70
Structural.....	26.17	16.72
Fence Erector	23.55	16.72

Painters:

(Heavy and Highway Bridges-

Guardrails-Lightpoles-Striping):

Bridge/Equipment Tender and/or Containment Builder	20.49	6.83
Brush and Roller	23.10	6.83
Elevated Tanks; Steeplejack Work; Bridge & Lead Abatement.....	24.10	6.83
Sandblasting and Water Blasting	23.85	6.83
Spray	23.60	6.83
Plumbers.....	28.39	14.30

WELDERS - Receive rate prescribed for craft performing operation to which welding is incidental.

**TRANSPORTATION CABINET
DIVISION OF CONSTRUCTION PROCUREMENT
COMPLIANCE SECTION
PROJECT WAGE RATES**

LABORERS:

Pendleton County:

GROUP 1 - Aging and Curing of Concrete, Asbestos Abatement Worker, Asphalt Plant, Asphalt, Batch Truck Dump, Carpenter Tender, Cement Mason Tender, Cleaning Of Machines, Concrete, Demolition, Dredging, Drill Tender, Environmental -- Nuclear, Radiation, Toxic and Hazardous Waste - Level D, Flagperson, Grade Checker, Hand Digging and Hand Back Filling, Highway Marker Placer, Landscaping, Mesh Handler and Placer, Puddler, Railroad, Rip-Rap and Grouter, Right-Of-Way, Sign, Guardrail and Fence Installer, Signal Person, Sound Barrier Installer, Storm and Sanitary Sewer, Swamper, Truck Spotter and Dumper and Wrecking of Concrete Forms, General Cleanup.

BASE RATE..... 20.36

FRINGE BENEFITS..... 9.90

GROUP 2 - Batter Board Man (Sanitary and Storm Sewer), Brickmason Tender, Mortar Mixer Operator, Scaffold Builder, Burner and Welder, Bushhammer, Chain Saw Operator, Concrete Saw Operator, Deckhand Scow Man, Dry Cement Handler, Environmental - Nuclear, Radiation, Toxic and Hazardous Waste - Level C, Forklift Operator For Masonary, Form Setter, Green Concrete Cutting, Hand Operated Grouter and Grinder Machine Operator, Jackhammer, Pavement Breaker, Paving Joint Machine, Pipelayer, Plastic Pipe Fusion, Power Driven Georgia Buggy and Wheel Barrow, Power Post Hole Digger, Precast Manhole Setter, Walk-Behind Tamper, Walk-Behind Trencher, Sand Blaster, Concrete Chipper, Surface Grinder, Vibrator Operator and Wagon Driller.

BASE RATE..... 20.61

FRINGE BENEFITS..... 9.90

GROUP 3 - Asphalt Luteman and Raker, Gunnite Nozzleman, Gunnite Operator and Mixer, Grout Pump Operator, Side Rail Setter, Rail Paved Ditch, Screw Operator, Tunnel (free air) and Water Blaster.

BASE RATE..... 20.66

FRINGE BENEFITS..... 9.90

GROUP 4 - Caisson Worker (free air), Cement Finisher, Environmental - Nuclear, Radiation, Toxic and Hazardous Waste - Levels A and B, Miner and Driller (free air), Tunnel Blaster and Tunnel Mucker (free air), Directional & Horizontal Boring, Air Track Driller (all types), Powderman & Blaster, Troxler & Concrete Tester if Laborer is utilized.

BASE RATE..... 21.26

FRINGE BENEFITS..... 9.90

**TRANSPORTATION CABINET
DIVISION OF CONSTRUCTION PROCUREMENT
COMPLIANCE SECTION
PROJECT WAGE RATES**

LABORERS: (continued)

Boone, Campbell and Kenton Counties:

Group 1

Asphalt Laborer, Carpenter Tender, Concrete Curing Applicator, Dump Man (Batch Truck), Guardrail And Fence Installer, Joint Setter, Laborer (Construction), Landscape Laborer, Highway Lighting Worker, Signalization Worker, Mesh Handlers And Placer, Right-Of-Way Laborer, Riprap Laborer And Grouter, Scaffold Erector, Seal Coating, Surface Treatment Or Road Mix Laborer, Sign Installer, Slurry Seal, Utility Man, Bridgeman, Handyman, Waterproofing Laborer, Flagperson, Hazardous Waste (Level D), Diver Tender, Zone Person & Traffic Control.

BASE RATE 25.27

FRINGE BENEFITS 7.50

GROUP 2

Skidsteer, Asphalt Raker, Concrete Puddler, Kettle Man (Pipeline), Machine Driven Tools (Gas, Electric, Air), Mason Tender, Brick Paver, Mortar Mixer, Power Buggy or Power Wheelbarrow, Sheeting & Shoring Man, Surface Grinder Man, Plastic Fusing Machine Operator, Pug Mill Operator, & Vacuum Devices (wet or dry), Rodding Machine Operator, Diver, Screw Man or Paver, Screed Person, Water Blast, Hand Held Wand, Pumps 4" and under (gas, air or electric), Hazardous Waste (Level C), Air Track and Wagon Drill, Bottom Person, Cofferdam (below 25 ft. deep), Concrete Saw Person, cutting with Burning Torch, Form Setter, Hand Spiker (Railroad), Pipelayer, Tunnel Laborer (without air) & Caisson, Underground Person (working in sewer and waterline, cleaning, repairing and reconditioning), Sandblaster Nozzleperson and Hazardous Waste (Level B).

BASE RATE 25.44

FRINGE BENEFITS 7.50

GROUP 3

Blaster, Mucker, Powder Person, Top Lander, Wrencher (Mechanical Joints and Utility Pipeline), Yarner, Hazardous Waste (Level A), Concrete Specialist, Concrete Crew in Tunnels (with air pressurized \$1.00 premium), Curb Setter & Cutter, Grade Checker, Utility Pipeline Tapper, Waterline, and Caulker.

BASE RATE 25.77

FRINGE BENEFITS 7.50

GROUP 4

Miner, Tunnel Laborer (with air-pressurized add \$1.00 to Base Rate) and Gunnite Nozzle Person.

BASE RATE 26.22

FRINGE BENEFITS 7.50

Signal person will receive the rate equal to the rate paid the labor classification for which he or she is signaling.

**TRANSPORTATION CABINET
DIVISION OF CONSTRUCTION PROCUREMENT
COMPLIANCE SECTION
PROJECT WAGE RATES**

OPERATING ENGINEERS: (continued)

Asphalt Paver; Automatic Subgrader Machine, Self-Propelled (CMI Type); Bobcat Type and/or Skid Steer Loader with Hoe Attachment Greater than 7,000 lbs.; Boring Machine More than 48"; Bulldozer; Endloader; Hydro Milling Machine; Kolman-type Loader (production type-Dirt); Lead Greaseman; Lighting & Traffic Signal Installation Equipment (includes all groups or classifications); Material Transfer Equipment (Shuttle Buggy) Asphalt; Pettibone-Rail Equipment; Power Grader; Power Scraper; Push Cat; Rotomill (all), Grinders & Planers of All types; Trench Machine (24" wide & under); & Vermeer type Concrete Saw

BASE RATE 29.37
FRINGE BENEFITS 11.16

A-Frame; Air Compressor on Tunnel Work (low pressure); Asphalt Plant Engineer; Bobcat-type and/or Skid Steer Loader with or without Attachments; Highway Drills (all types); Locomotive (narrow gauge); Material Hoist/Elevator; Mixer, Concrete (more than one bag capacity); Mixer, one bag capacity (Side Loader); Power Boiler (Over 15 lbs. Pressure) Pump Operator installing & operating Well Points; Pump (4" & over discharge); Roller, Asphalt; Rotovator (lime soil stabilizer); Switch & Tie Tampers (without lifting & aligning device); Utility Operator (Small equipment); & Welding Machines.

BASE RATE 28.33
FRINGE BENEFITS 11.16

Backfiller; Ballast Re-locator; Bars, Joint & Mesh Installing Machine; Batch Plant; Boring Machine Operator (48" or less); Bull Floats; Burlap & Curing Machine; Concrete Plant (capacity 4 yd. & under); Concrete Saw (Multiple); Conveyor (Highway); Crusher; Deckhand; Farm-type Tractor with attachments (highway) except Masonry); Finishing Machine; Fireperson, Floating Equipment (all types); Fork Lift (highway); Form Trencher; Hydro Hammer; Hydro Seeder; Pavement Breaker; Plant Mixer; Post Driver; Post Hole Digger (Power Auger); Power Brush Burner; Power Form Handling Equipment; Road Widening Trencher; Roller (Brick, Grade & Macadam); Self-Propelled Power Spreader; Self-Propelled Power Subgrader; Steam Fireperson; Tractor (Pulling Sheepfoot, Roller or Grader); & Vibratory Compactor with Integral Power.

BASE RATE 27.15
FRINGE BENEFITS 11.16

**TRANSPORTATION CABINET
DIVISION OF CONSTRUCTION PROCUREMENT
COMPLIANCE SECTION
PROJECT WAGE RATES**

OPERATING ENGINEERS: (continued)

Compressor (Portable, Sewer, Heavy & Highway); Drum Fireperson (Asphalt); Generator; Masonry fork Lift; Inboard-Outboard Motor Boat Launch; Masonry Fork Lift; Oil Heater (asphalt plant); Oiler; Power Driven Heater; Power Sweeper & Scrubber; Pump (under 4” discharge); Signalperson; Tire Repairperson; & VAC/ALLS.

BASE RATE 21.69
FRINGE BENEFITS..... 11.16

Master Mechanic and Boom from
150 to 180.

BASE RATE..... 29.74
FRINGE BENEFITS..... 11.16

Boom from 180 and over.

BASE RATE..... 29.99
FRINGE BENEFITS..... 11.16

Fringe benefit amounts are applicable for all hours worked except when otherwise noted.

These rates are listed pursuant to Kentucky Determination No. CR-09-IV HWY dated July 1, 2009 and/or Federal Decision No. KY20100028 dated March 12, 2010, modification #0 dated March 12, 2010.

No laborer, workman or mechanic shall be paid at a rate less than that of the General Laborer except those classified as bona fide apprentices.

Apprentices or trainees shall be permitted to work as such subject to Administrative Regulations adopted by the Commissioner of Workplace Standards. Copies of these regulations will be furnished upon request from any interested person.

Before using apprentices on the job the contractor shall present to the Contracting Officer written evidence of registration of such employees in a program of a State apprenticeship and training agency approved and recognized by the U. S. Bureau of Apprenticeship and Training. In the absence of such a State agency, the contractor shall submit evidence of approval and registration by the U. S. Bureau of Apprenticeship and Training.

The contractor shall submit to the Contracting Officer, written evidence of the established apprenticeship-journeyman ratios and wage rates in the project area, which will be the basis for establishing such ratios and rates for the project under the applicable contract provisions.

**TRANSPORTATION CABINET
DIVISION OF CONSTRUCTION PROCUREMENT
COMPLIANCE SECTION
PROJECT WAGE RATES**

TO: EMPLOYERS/EMPLOYEES

PREVAILING WAGE SCHEDULE:

The wages indicated on this wage schedule are the least permitted to be paid for the occupations indicated. When an employee works in more than one classification, the employer must record the number of hours worked in each classification at the prescribed hourly base rate.

OVERTIME:

Overtime is to be paid after an employee works eight (8) hours a day or forty (40) hours a week, whichever gives the employee the greater wages. At least time and one-half the base rate is required for all overtime. A laborer, workman or mechanic and an employer may enter into a written agreement or a collective bargaining agreement to work more than eight (8) hours a calendar day but not more than ten (10) hours a calendar day for the straight time hourly rate.

Wage violations or questions should be directed to the designated Engineer or the undersigned.

Ryan Griffith, Director
Division of Construction Procurement
Frankfort, Kentucky 40622

PART IV
INSURANCE

INSURANCE

The Contractor shall carry the following insurance in addition to the insurance required by law:

1. Contractor's Public Liability Insurance not less than \$100,000.00 for damages arising out of bodily injuries to or death to one person. Not less than \$300,000.00 for damages arising out of bodily injuries to or death to two or more persons.
2. Contractor's Property Damages Liability Insurance. Not less than \$100,000.00 for all damages arising out of injury or destruction of property in any one accident. Not less than \$300,000.00 for all damages during the policy period.
3. Contractor's Protective Public Liability and Property Damage Insurance. The contractor shall furnish evidence with respect to operations performed for him by subcontractors that he carries in his own behalf for the above stipulated amounts.
4. The insurance required above must be evidenced by a Certificate of Insurance and this Certificate of Insurance must contain one of the following statements:
 - a. "policy contains no deductible clauses."
 - b. "policy contains _____ (amount) deductible property damage clause but company will pay claim and collect the deductible from the insured."
5. WORKMEN'S COMPENSATION INSURANCE. The contractor shall furnish evidence of coverage of all his employees or give evidence of self-insurance by submitting a copy of a certificate issued by the Workmen's Compensation Board.

PART V
BID ITEMS

CONTRACT ID: 102174
COUNTY: CAMPBELL
PROPOSAL: 019GR10P053-FD05

PAGE: 1
LETTING: 05/28/10
CALL NO: 411

LINE NO	ITEM	DESCRIPTION	APPROXIMATE QUANTITY	UNIT	UNIT PRICE	AMOUNT
SECTION 0001 ROADWAY						
0010	00190	LEVELING & WEDGING PG64-22	440.000	TON		
0020	00301	CL2 ASPH SURF 0.38D PG64-22	2,830.000	TON		
0030	00388	CL3 ASPH SURF 0.38B PG64-22	785.000	TON		
0040	02014	BARRICADE-TYPE III	8.000	EACH		
0050	02562	SIGNS	780.000	SQFT		
0060	02650	MAINTAIN & CONTROL TRAFFIC KY 1120	(1.00)	LS		
0070	02650	MAINTAIN & CONTROL TRAFFIC KY 547	(1.00)	LS		
0080	02676	MOBILIZATION FOR MILL & TEXT KY 1120	(1.00)	LS		
0090	02676	MOBILIZATION FOR MILL & TEXT KY 547	(1.00)	LS		
0100	02677	ASPHALT PAVE MILLING & TEXTURING	825.000	TON		
0110	02720	SIDEWALK-4 IN CONCRETE	275.000	SQYD		
0120	02775	ARROW PANEL	1.000	EACH		
0130	03240	BASE FAILURE REPAIR KY 1120	236.000	SQYD		
0140	03240	BASE FAILURE REPAIR KY 547	60.000	SQYD		
0150	06510	PAVE STRIPING-TEMP PAINT-4 IN	17,000.000	LF		
0160	06514	PAVE STRIPING-PERM PAINT-4 IN	83,910.000	LF		
0170	06565	PAVE MARKING-THERMO X-WALK-6 IN	1,878.000	LF		
0180	06568	PAVE MARKING-THERMO STOP BAR-24IN	448.000	LF		
0190	06573	PAVE MARKING-THERMO STR ARROW	2.000	EACH		
0200	06574	PAVE MARKING-THERMO CURV ARROW	7.000	EACH		

KENTUCKY TRANSPORTATION CABINET
DEPARTMENT OF HIGHWAYS
FRANKFORT, KY 40622

CONTRACT ID: 102174
COUNTY: CAMPBELL
PROPOSAL: 019GR10P053-FD05

PAGE: 2
LETTING: 05/28/10
CALL NO: 411

LINE NO	ITEM	DESCRIPTION	APPROXIMATE QUANTITY	UNIT	UNIT PRICE	AMOUNT
0210	06576	PAVE MARKING--THERMO ONLY	1.000	EACH		
0220	10020NS	FUEL ADJUSTMENT	5,473.000	DOLL	1.00	5,473.00
0230	10030NS	ASPHALT ADJUSTMENT	9,641.000	DOLL	1.00	9,641.00
0240	23158ES505	DETECTABLE WARNINGS	354.000	SQFT		
SECTION 0002 DEMOBLIZATION						
0250	02569	DEMOBILIZATION (AT LEAST 1.5%)		LUMP		
		TOTAL BID				