



**CALL NO. 406**

**CONTRACT ID. 222969**

**HOPKINS - MCLEAN - MUHLENBERG - WEBSTER COUNTIES**

**FED/STATE PROJECT NUMBER 121GR22M054 - FE02**

**DESCRIPTION VARIOUS ROUTES IN DISTRICT 2**

**WORK TYPE BRIDGE DECK RESTORATION & WATERPROOFING**

**PRIMARY COMPLETION DATE 7/31/2023**

**LETTING DATE: July 21,2022**

Sealed Bids will be received electronically through the Bid Express bidding service until 10:00 AM EASTERN DAYLIGHT TIME July 21,2022. Bids will be publicly announced at 10:00 AM EASTERN DAYLIGHT TIME.

**NO PLANS ASSOCIATED WITH THIS PROJECT.**

**REQUIRED BID PROPOSAL GUARANTY:** Not less than 5% of the total bid.

## TABLE OF CONTENTS

PART I	SCOPE OF WORK
	<ul style="list-style-type: none"><li>• PROJECT(S), COMPLETION DATE(S), &amp; LIQUIDATED DAMAGES</li><li>• CONTRACT NOTES</li><li>• STATE CONTRACT NOTES</li><li>• SPECIAL NOTE(S) APPLICABLE TO PROJECT</li><li>• ASBESTOS ABATEMENT REPORT</li><li>• MATERIAL SUMMARY</li><li>• BRIDGE DRAWINGS</li></ul>
PART II	SPECIFICATIONS AND STANDARD DRAWINGS
	<ul style="list-style-type: none"><li>• SPECIFICATIONS REFERENCE</li><li>• SUPPLEMENTAL SPECIFICATION</li><li>• STANDARD DRAWINGS THAT APPLY</li></ul>
PART III	EMPLOYMENT, WAGE AND RECORD REQUIREMENTS
	<ul style="list-style-type: none"><li>• LABOR AND WAGE REQUIREMENTS</li><li>• EXECUTIVE BRANCH CODE OF ETHICS</li><li>• KENTUCKY EQUAL EMPLOYMENT OPPORTUNITY ACT OF 1978 LOCALITY / STATE</li><li>• PROJECT WAGE RATES / STATE FUNDED</li></ul>
PART IV	INSURANCE
PART V	BID ITEMS

**PART I**  
**SCOPE OF WORK**

## ADMINISTRATIVE DISTRICT - 02

**CONTRACT ID - 222969**

**121GR22M054 - FE02**

**COUNTY - HOPKINS**

**PCN - MB054041A2201**

**FE02 054 041A B00208N 06.78**

NEBO ROAD (US 41A) BRIDGE 054B00208N OVER POND CREEK AT MP 06.78BRIDGE DECK RESTORATION & WATERPROOFING

GEOGRAPHIC COORDINATES LATITUDE 37:22:48.00 LONGITUDE 87:36:22.00

ADT

**COUNTY - MCLEAN**

**PCN - MB07500812201**

**FE02 075 0081 B00074N 08.37**

SACRAMENTO - RUMSEY ROAD (KY 81) BRIDGE 075B00074N OVER CYPRESS CREEK AT MP 08.37BRIDGE DECK RESTORATION & WATERPROOFING

GEOGRAPHIC COORDINATES LATITUDE 37:49:03.00 LONGITUDE 87:24:52.00

ADT

**PCN - MB07500852201**

**FE02 075 0085 B00070N 06.82**

SACRAMENTO - ISLAND ROAD (KY 85) BRIDGE 075B00070N OVER CYPRESS CREEK AT MP 06.82BRIDGE DECK RESTORATION & WATERPROOFING

GEOGRAPHIC COORDINATES LATITUDE 37:26:46.00 LONGITUDE 87:11:53.00

ADT

**COUNTY - MUHLENBERG**

**PCN - MB08901892201**

**FE02 089 0189 B00110N 10.00**

ROBERT L. DRAPER WAY (KY 189) BRIDGE 089B00110N OVER FIELD AT MP 10.00BRIDGE DECK RESTORATION & WATERPROOFING

GEOGRAPHIC COORDINATES LATITUDE 37:12:47.00 LONGITUDE 87:11:29.00

ADT

**COUNTY - WEBSTER**

**PCN - MB11701092201**

**FE02 117 0109 B00118N 01.07**

SOUTH BROADWAY STREET (KY 109) BRIDGE 117B00118N OVER OWENS CREEK AT MP 01.07BRIDGE DECK RESTORATION & WATERPROOFING

GEOGRAPHIC COORDINATES LATITUDE 37:23:39.00 LONGITUDE 87:45:38.00

ADT

### COMPLETION DATE(S):

COMPLETED BY 07/31/2023	APPLIES TO ENTIRE PROJECT
30 CALENDAR Days	APPLIES TO 054B00208N
30 CALENDAR Days	APPLIES TO 075B00070N
30 CALENDAR Days	APPLIES TO 075B00074N
30 CALENDAR Days	APPLIES TO 089B00110N
30 CALENDAR Days	APPLIES TO 117B00118N

## **CONTRACT NOTES**

### **PROPOSAL ADDENDA**

All addenda to this proposal must be applied when calculating bid and certified in the bid packet submitted to the Kentucky Department of Highways. Failure to use the correct and most recent addenda may result in the bid being rejected.

### **BID SUBMITTAL**

Bidder must use the Department's electronic bidding software. The Bidder must download the bid file located on the Bid Express website ([www.bidx.com](http://www.bidx.com)) to prepare a bid packet for submission to the Department. The bidder must submit electronically using Bid Express.

### **JOINT VENTURE BIDDING**

Joint venture bidding is permissible. All companies in the joint venture must be prequalified in one of the work types in the Qualifications for Bidders for the project. The bidders must get a vendor ID for the joint venture from the Division of Construction Procurement and register the joint venture as a bidder on the project. Also, the joint venture must obtain a digital ID from Bid Express to submit a bid. A joint bid bond of 5% may be submitted for both companies or each company may submit a separate bond of 5%.

### **UNDERGROUND FACILITY DAMAGE PROTECTION**

The contractor shall make every effort to protect underground facilities from damage as prescribed in the Underground Facility Damage Protection Act of 1994, Kentucky Revised Statute KRS 367.4901 to 367.4917. It is the contractor's responsibility to determine and take steps necessary to be in compliance with federal and state damage prevention directives. When prescribed in said directives, the contractor shall submit Excavation Locate Requests to the Kentucky Contact Center (KY811) via web ticket entry. The submission of this request does not relieve the contractor from the responsibility of contacting non-member facility owners, whom shall be contacted through their individual Protection Notification Center. Non-compliance with these directives can result in the enforcement of penalties.

### **REGISTRATION WITH THE SECRETARY OF STATE BY A FOREIGN ENTITY**

Pursuant to KRS 176.085(1)(b), an agency, department, office, or political subdivision of the Commonwealth of Kentucky shall not award a state contract to a person that is a foreign entity required by [KRS 14A.9-010](#) to obtain a certificate of authority to transact business in the Commonwealth ("certificate") from the Secretary of State under [KRS 14A.9-030](#) unless the person produces the certificate within fourteen (14) days of the bid or proposal opening. If the foreign entity is not required to obtain a certificate as provided in [KRS 14A.9-010](#), the foreign entity should identify the applicable exception. Foreign entity is defined within [KRS 14A.1-070](#).

**For all foreign entities required to obtain a certificate of authority to transact business in the Commonwealth, if a copy of the certificate is not received by the contracting agency within the time frame identified above, the foreign entity's solicitation response shall be deemed non-responsive or the awarded contract shall be cancelled.**

Businesses can register with the Secretary of State at <https://secure.kentucky.gov/sos/ftbr/welcome.aspx>.

### **SPECIAL NOTE FOR PROJECT QUESTIONS DURING ADVERTISEMENT**

Questions about projects during the advertisement should be submitted in writing to the Division of Construction Procurement. This may be done by fax (502) 564-7299 or email to [kytc.projectquestions@ky.gov](mailto:kytc.projectquestions@ky.gov). The Department will attempt to answer all submitted questions. The Department reserves the right not to answer if the question is not pertinent or does not aid in clarifying the project intent.

The deadline for posting answers will be 3:00 pm Eastern Daylight Time, the day preceding the Letting. Questions may be submitted until this deadline with the understanding that the later a question is submitted, the less likely an answer will be able to be provided.

The questions and answers will be posted for each Letting under the heading "Questions & Answers" on the Construction Procurement website ([www.transportation.ky.gov/contract](http://www.transportation.ky.gov/contract)). The answers provided shall be considered part of this Special Note and, in case of a discrepancy, will govern over all other bidding documents.

### **HARDWOOD REMOVAL RESTRICTIONS**

The US Department of Agriculture has imposed a quarantine in Kentucky and several surrounding states, to prevent the spread of an invasive insect, the emerald ash borer. Hardwood cut in conjunction with the project may not be removed from the state. Chipping or burning on site is the preferred method of disposal.

### **INSTRUCTIONS FOR EXCESS MATERIAL SITES AND BORROW SITES**

Identification of excess material sites and borrow sites shall be the responsibility of the Contractor. The Contractor shall be responsible for compliance with all applicable state and federal laws and may wish to consult with the US Fish and Wildlife Service to seek protection under Section 10 of the Endangered Species Act for these activities.

### **ACCESS TO RECORDS**

The contractor, as defined in KRS 45A.030 (9) agrees that the contracting agency, the Finance and Administration Cabinet, the Auditor of Public Accounts, and the Legislative Research Commission, or their duly authorized representatives, shall have access to any books, documents, papers, records, or other evidence, which are directly pertinent to this contract for the purpose of financial audit or program review. Records and other prequalification information confidentially

disclosed as part of the bid process shall not be deemed as directly pertinent to the contract and shall be exempt from disclosure as provided in KRS 61.878(1)(c). The contractor also recognizes that any books, documents, papers, records, or other evidence, received during a financial audit or program review shall be subject to the Kentucky Open Records Act, KRS 61.870 to 61.884.

In the event of a dispute between the contractor and the contracting agency, Attorney General, or the Auditor of Public Accounts over documents that are eligible for production and review, the Finance and Administration Cabinet shall review the dispute and issue a determination, in accordance with Secretary's Order 11-004.

April 30, 2018

## **SPECIAL NOTE FOR RECIPROCAL PREFERENCE**

### **RECIPROCAL PREFERENCE TO BE GIVEN BY PUBLIC AGENCIES TO RESIDENT BIDDERS**

By reference, KRS 45A.490 to 45A.494 are incorporated herein and in compliance regarding the bidders residency. Bidders who want to claim resident bidder status should complete the Affidavit for Claiming Resident Bidder Status along with their bid in the electronic bidding software. Submittal of the Affidavit should be done along the bid in Bid Express.

April 30, 2018



**SPECIAL NOTES  
DISTRICT NO. 2  
BRIDGE DECK RESTORATION AND WATERPROOFING  
VARIOUS COUNTIES  
CID 222969 ~ 121GR22M054**

**FE02 054 041A B00208N 06.78**

Hopkins County ~ US 41A (Nebo Road) over Pond Creek

***Geographic Coordinates***

Latitude 37° 22' 48.00'' (37.3800)

Longitude -87° 36' 22.00'' (-87.6061)

**Description**

58' PCIB Span, Drawing No. 21671

**FE02 075 0085 B00070N 06.82**

McClellan County ~ KY 85 (Sacramento – Island Road) over Cypress Creek

***Geographic Coordinates***

Latitude 37° 26' 46.00'' (37.4460)

Longitude -87° 11' 53.00'' (-87.1981)

**Description**

33'-39'-33' Composite PCBB Spans, Drawing No. 21965

**FE02 075 0081 B00074N 08.37**

McClellan County ~ KY 81(Sacramento – Rumsey Road) over Cypress Creek

***Geographic Coordinates***

Latitude 37° 29' 25.00'' (37.4903)

Longitude -87° 14' 43.00'' (-87.2452)

**Description**

41'-53'-41' PCIB Spans, Drawing No. 23017

**FE02 089 0189 B00110N 10.00**

Muhlenberg County ~ KY 189 (Robert L. Draper Way) over Field

***Geographic Coordinates***

Latitude 37° 12' 47.00'' (37.2132)

Longitude -87° 11' 29.00'' (-87.1913)

**Description**

52'-59'-52' PCIB Spans, Drawing No. 20162

**FE02 117 0109 B00118N 01.07**

Webster County ~ KY 109 (South Broadway Steet) over Owens Creek

***Geographic Coordinates***

Latitude 37° 23' 39.00'' (37.3942)

Longitude -87° 45' 38.00'' (-87.7607)

**Description**

28' Composite PCBB Span, Drawing No. 21019

**SPECIAL NOTES FOR BRIDGE DECK  
RESTORATION AND WATERPROOFING**

SPECIAL NOTE FOR BRIDGE DECK RESTORATION AND WATERPROOFING  
WITH CONCRETE OVERLAYS

SPECIAL NOTE FOR CONTRACT COMPLETION DATE AND PENALTIES ON  
BRIDGE REPAIR CONTRACTS

SPECIAL NOTE FOR MAINTAINING AND CONTROLLING TRAFFIC

## **SPECIAL NOTE FOR BRIDGE DECK RESTORATION AND WATERPROOFING WITH CONCRETE OVERLAYS**

- 1. DESCRIPTION.** Perform all work in accordance with the Kentucky Transportation Cabinet, Department of Highway's Standard Specifications for Road and Bridge Construction and applicable Supplemental Specifications, the Standard Drawings (current editions), this Note, and the attached detail drawings. Section references are to the Standard Specifications. This work consists of the following: (1) Furnish all labor, materials, tools, and equipment, (2) Machine prep the existing slab, (3) Complete full-depth and partial depth repairs as directed by the Engineer, (4) Repair/replace damaged and corroded reinforcing bars, (5) Place new concrete overlay and epoxy-sand slurry in accordance with Section 606, (6) Complete asphalt approach pavement, and (7) Any other work specified as part of this contract. All construction will be in accordance with Section 606 unless otherwise specified.
- 2. MATERIALS.**

  - A. Latex Concrete.** See Section 606.03.17.
  - B. Class "M" Concrete.** Use either "M1" or "M2". See Section 601.
  - C. Bituminous Asphalt.** Use CL2 ASPH SURF 0.38D PG64-22.
  - D. Epoxy-Sand Slurry.** See Section 606.03.10.
- 3. CONSTRUCTION.**

  - A. Machine Preparation of Existing Slab.** Remove concrete from existing slab to a depth of at least ¼" below the existing surface, and remove all patches completely, in accordance with the requirements of Section 606.03.03.
  - B. Remove Existing Overlay (117B00118) .** In addition to Section 606.03.03, totally remove the existing concrete overlay by milling.
  - C. Partial Depth Slab Repair and Latex Overlay.** Remove areas determined to be unsound by the Engineer via hydro-demolition or via hand held jackhammers weighing less than 45lbs in accordance with Section 606.02.10 D. Repair/Replace all damaged or severely corroded reinforcing bars prior to partial depth repair operation. The Department will not measure material removal and will consider this work incidental to the bid item "PARTIAL DEPTH PATCHING". Mix and place Latex Modified Concrete Overlay in accordance with Sections 606.03.08 and 606.03.17.
  - D. Asphalt Approach Pavement.** Mill each existing asphalt approach to the distance indicated in the attached detailed drawings. Remove the bituminous material uniformly by making an edge key, so as to provide a smooth transition to the finished bridge when a new bituminous overlay of compacted depth of approximately 1½" is added to the approaches. The grinding depth may vary depending on the condition of the existing approach and final elevation of bridge end. Dispose of all removed material away from the site.

- E. Approach Pavement Repair (117B00118).** The Contractor shall repair any and all damage to the approach pavement due to this construction. A new asphalt surface wedge up to three feet for all approaches to each structure in this project shall be placed and compacted to the satisfaction of the Engineer prior to allowing traffic back onto the structure after each section of the armored edge for concrete is replaced. No additional payment will be allowed for this work, as it will be considered incidental to the pay item “Armored Edge for Concrete”.
  - F. Surface Texturing.** Texture the concrete surface of the overlay in accordance with Section 609.03.10.
  - G. Pavement Markings.** Restore pavement markings to original patterns and/or as directed by the Engineer in accordance with Sections 713, 714 and 837. See Standard Drawings TPM-115 and TPM-207 Current Edition.
  - H. Verifying Field Conditions.** The Contractor shall field verify all dimensions before ordering any material. New material that is unsuitable due to variation in existing structure shall be replaced at the Contractors expense.
  - I. Damage to the Structure.** The Contractor shall bear all responsibility and expense for all damage to the structure during the repair work even to removal and replacement of a fallen span, should the fallen span result from the Contractor’s actions.
- 4. MEASUREMENT.** See Section 606 and the following:
- A. Machine Preparation of Slab, Remove Epoxy Bit Foreign Overlay, Blast Cleaning, Epoxy Sand Slurry and Bridge Overlay Approach Pavement.** The Department will measure the removal of the existing overlay in square yards.
  - B. Latex Modified Concrete for Overlay.** The Department will measure the quantity in cubic yards using the theoretical volume as follows for each bridge:

<b>054B00208N</b>	<b>(5046 SFx1.50”) = 23.4 CY</b>
<b>075B00070N</b>	<b>(5112 SFx1.50”) = 23.7 CY</b>
<b>075B00074N</b>	<b>(3632 SFx1.50”) = 16.8 CY</b>
<b>089B00110N</b>	<b>(7374 SFx1.50”) = 34.1 CY</b>
<b>117B00118N</b>	<b>(32’0”x 30’0”x 1.50”) = 4.4 CY</b>
  - C. Partial Depth Patching.** The Department will measure the quantity in cubic yards by deducting the theoretical volume of bridge deck overlay (LMC) from the total volume (as indicated by the batch quantity tickets) of Concrete required to obtain the finished grade shown on the plans or established by the Engineer.
  - D. Concrete Class M Full Depth Patch and Concrete Latex Overlay.** The Department will measure the quantity in cubic yards.
  - E. Steel Reinforcement.** The Department will measure any reinforcing steel necessary for the partial or full depth patch in pounds.
  - F. Pave Striping-Perm 4 Inch.** The Department will measure the quantity in lineal feet.

5. **PAYMENT.** See Section 606 and the following:
  - A. **Remove Existing Overlay (08510).** In addition to Section 606.03.03, totally remove the existing asphalt overlay by milling.
  - B. **Machine Preparation of Slab (08551).** The Department will make payment for the machine preparation of the existing slab.
  - C. **Partial Depth Patching (24094EC).** The Department will make payment for removing exiting materials, furnishing and placing all new materials completed and accepted.
  - D. **Concrete Class M Full Depth Patch (08526).** The Department will make payment for removing exiting materials, furnishing and placing all new materials.
  - E. **Blast Cleaning (08549).** The Department will make payment for blast cleaning all surfaces specified.
  - F. **Epoxy Sand Slurry (08504).** The Department will make payment for furnishing and placing all new materials as specified.
  - G. **Concrete Latex Overlay (08534).** The Department will make payment for furnishing and placing all new material as specified.
  - H. **Steel Reinforcement (08150).** The Department will make payment for steel reinforcement, if necessary.
  - I. **Asphalt Approach Pavement (03304).** The Department will make payment for removing existing materials, furnishing and placing all new materials as specified.
  - J. **Pave Striping-Perm 4 Inch (06514).** The Department will make payment for furnishing and placing permanent striping as specified.

**SPECIAL NOTE FOR CONTRACT COMPLETION DATE AND  
PENALTIES ON BRIDGE REPAIR CONTRACTS**

- 1. COMPLETION DATE.** The Contractor has the option of selecting the starting date for this Contract. Once selected, notify the Department in writing of the date selected at least two weeks prior to beginning work. All work is to be completed by the date listed below. An allotted number of Calendar days are assigned to each structure in this contract as shown below.

<u>STRUCTURE</u>	<u>NO. OF CALENDAR DAYS</u>	<u>COMPLETION DATE</u>
054B00208N	30	July 31, 2023
075B00070R	30	July 31, 2023
075B00074N	30	July 31, 2023
089B00110N	30	July 31, 2023
117B00118N	30	July 31, 2023

Contrary to Section 108.07.03, the Engineer will begin charging calendar days for a structure on the day the Contractor starts work or sets up traffic control on that particular structure. A **penalty of \$500.00 per day** will be assessed when the allotted number of calendar days is exceeded for each structure.

All construction must be completed in accordance with the weather limitations specified in Section 606 and/or Section 601 as applicable. No extension of Contract time will be granted due to inclement weather or temperature limitations that occur due to starting work on the Contract or a structure late in the construction season.

## SPECIAL NOTE FOR TRAFFIC CONTROL ON BRIDGE REPAIR CONTRACTS

### 1. TRAFFIC CONTROL GENERAL

Except as provided herein, traffic shall be maintained in accordance with the Standard Specifications (current edition), Section 112. Except for the roadway and traffic control bid items listed, all items of work necessary to maintain and control traffic will be paid at the lump sum bid price to "Maintain and Control Traffic". Contrary to Section 106.01, traffic control devices used on this project may be new or used in new condition, at the beginning of the work and maintained in like new condition until completion of the work.

### 2. TRAFFIC COORDINATOR

Furnish a Traffic Coordinator as per Section 112. The Traffic Coordinator shall inspect the project maintenance of traffic, at least three times daily, or as directed by the Engineer, during the Contractor's operations and at any time a lane closure is in place. The personnel shall have access on the project to a radio or telephone to be used in case of emergencies or accidents. The Traffic Coordinator shall report all incidents throughout the work zone to the Engineer on the project. The Contractor shall furnish the name and telephone number where the Traffic Coordinator can be contacted at all times.

### 3. SIGNS

Contrary to Section 112.04.02, only long-term signs (sign intended to be continuously in place for more than 3 days) will be measured for payment; short term signs (signs intended to be left in place for 3 days or less) will not be measured for payment but will be incidental to Maintain and Control Traffic.

The contractor is to install warning signs for wide loads in advance of the bridge under the direction of the Engineer. The Department will not measure installation, maintenance, or removal for payment, and will consider these incidentals to Maintain and Control Traffic.

### 4. TEMPORARY PAVEMENT STRIPING

Skip lines and/or solid lines through the length of the tapers for lane closures and other striping as directed by the Engineer shall be temporarily covered with 6" black removable tape. Permanent removal of all other pavement striping for traffic control shall be considered incidental to Maintain and Control Traffic. Temporary pavement striping shall be paid only once per course in accordance with Section 112.04.07. The Contractor shall replace any temporary striping that becomes damaged or fails to adhere to the pavement before dark on the day of the notification. **A penalty of \$500.00 per day will be assessed for failing to replace temporary striping within this time limit.**

### 5. PROJECT PHASING & CONSTRUCTION PROCEDURES

One lane of traffic shall be maintained on each bridge in accordance with Standard Drawing No. TTC-100 and TTC-110 C.E. The minimum clear lane width required is as follows:

<u>Structure</u>	<u>Clear Lane Width</u>
054B00208N	12'-0"
075B00070N	12'-0"
075B00074N	12'-0"
089B00110N	12'-0"
117B00118N	12'-0"



## 6. TEMPORARY SIGNAL

Provide, install, and maintain a temporary traffic signal as specified below. The Contractor must provide a 24-hour contact person and number available to maintain the temporary signals as needed.

<u>Structure</u>	<u>Signal</u>
054B00208N	2 Phase
075B00070N	2 Phase
075B00074N	2 Phase
089B00110N	2 Phase
117B00118N	2 Phase

## 7. MEASUREMENT.

### **Temporary Signs:**

The Cabinet will measure this item by “Square Feet”.

### **Maintain and Control Traffic:**

The Cabinet will measure this item by “Lump Sum”.

### **Lane Closure, and Temp Signal 2 Phase:**

The Cabinet will measure this item by “Each”.

### **Pave Striping-Temp Rem Tape-B, W, and Y:**

The Department will measure the quantity in “Linear Feet”.

## 8. PAYMENT.

### **Temporary Signs (02562)**

Payment at the contract unit price for “Square Feet” is full compensation for all items to complete this work as specified.

### **Maintain and Control Traffic (02650):**

Payment at the contract unit price for “Lump Sum” is full compensation for all items to complete this work as specified.

### **Lane Closure (02653) and Temp Signal 2 Phase (04933):**

Payment at the contract unit price “Each” is full compensation for all items to complete this work as specified.

### **Pave Striping-Temp Rem Tape-B (06549), W (06550), and Y (06551):**

Payment at the contract unit price “Lineal Feet” is full compensation for all items to complete this work as specified.



COMMONWEALTH OF KENTUCKY  
TRANSPORTATION CABINET  
transportation.ky.gov

Andy Beshear  
GOVERNOR

Jim Gray  
SECRETARY

## Asbestos Inspection Report

To: Tom Mathews

District: 2

Date: June 20, 2022

Conducted By: O'Dail Lawson

Report Prepared By: O'Dail Lawson

---

### Project and Structure Identification

Project Number: CID 222969

Structure ID: Hopkins 054B00208N

Structure Location: US-0041 (Nebo Road) over Pond Creek

Sample Description: Any suspect materials collected were negative for asbestos.

Inspection Date: June 14<sup>th</sup>, 2022

### Results and Recommendations

The results of the samples collected were negative for the presence of asbestos above 1%.  
No abatement is required at this time.

It is recommended that this report accompany the 10-Day Notice of Intent for Demolition ([Notification Form DEP 7036](#)) which is to be submitted to the Kentucky Division of Air Quality prior to abatement, demolition, or renovation of any building or structure in the Commonwealth.

**MRS, INC.** *MRS, Inc. Analytical Laboratory Division*

332 West Broadway / Suite # 902  
 Louisville, Kentucky - 40202 - 2133

(502) 495-1212  
 Fax: (502) 491-7111

**BULK SAMPLE ASBESTOS ANALYSIS**

Analysis N#      # 3206182      Address: Hopkins County 054 B00208N  
 Client Name:     K Y T C  
 Sampled By:      O'Dail Lawson

		% FIBROUS ASBESTOS				% NON-ASBESTOS FIBERS					
Sample ID	Color	Layered	Fibrous	Chrysotile	Amosite	crocidolite	Others	Cellulose	Fiberglass	Syn. Fiber	Other/Mat.
#208-1	Black	Yes	No				None				100%

Methodology : EPA Method 600/R-93-116

Date Analyzed : 18-Jun-22

Analyst : Winterford Mensah

Reviewed By:  Signature

The test relates only to the items tested. This report does not represent endorsement by NVLAP or any agency of the U.S Government. Partial Reproduction of any part of this report is strictly prohibited. Samples shall be retained for (30) days.

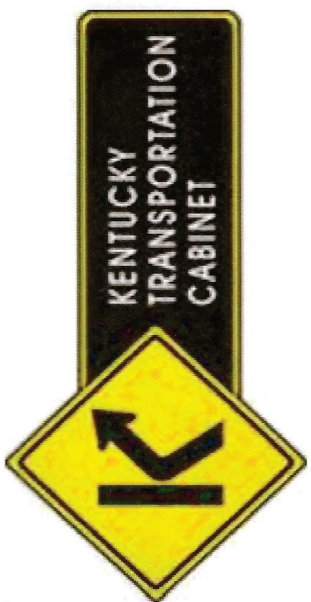

# Chain of Custody Record

## Kentucky Transportation Cabinet

200 Mero Street, 5th Floor West  
Frankfort, Kentucky 40622  
(502) 564-7250 fax (502) 564-5655

O'Dail Lawson [odail.lawson@ky.gov](mailto:odail.lawson@ky.gov)  
W4-06-06  
Address: 200 Mero Street Frankfort KY  
Phone: 502-782-5020 Fax: 502-564-5655  
N/A = Not Applicable  
PO#:  
Project ID: Hopkins 054 B00208N

Client Information KY TRANSPORTATION CABINET

Results Code: US 41 over Pons Creek

Samplers (Signature):

*[Handwritten Signature]*

Sample ID	Sample Description	Collected		Analysis Requested	Matrix	Color	Cont. Type	Preservative
		Date	Time					
208-1	Joins Compounds	4/14/22	10:55	Asbestos bulk.	Rubber	black		N/A

Relinquished By: \_\_\_\_\_ Date/Time: \_\_\_\_\_

Received By: *[Handwritten Signature]* Date/Time: 6/14/22

Relinquished By: \_\_\_\_\_ Date/Time: \_\_\_\_\_

Received at Lab By: \_\_\_\_\_ Date/Time: \_\_\_\_\_

**ENVIRONMENTAL TRAINING CONCEPTS, INC**

P.O Box 99603 Louisville, KY 40269  
(502)640-2951

Certification Number: ETC-AIR-031522-00137

**O'Dail Lawson**

has on 03-15-2022, attended and successfully completed the requirements and passed the examination with a score of 70% of better on the entitled course.

**ASBESTOS INSPECTOR REFRESHER**

Training was in accordance with 40 CFR Part 763 (AHERA) approved by the Commonwealth of Kentucky, the Indiana Department of Environmental Management, Tennessee Department of Environment & Conservation and The Arkansas Department of Environmental Quality. The above student received requisite training for Asbestos Accreditation under Title II of the Toxic Substance Act (TSCA).

Conducted at: 1220 KY Mills Drive, Louisville, KY

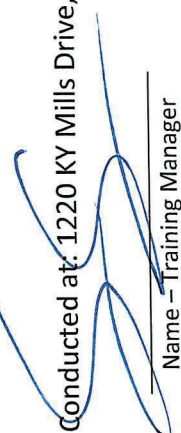
  
Name - Training Manager

Expiration Date: 03-15-2023

  
Name - Instructor



COMMONWEALTH OF KENTUCKY  
TRANSPORTATION CABINET  
transportation.ky.gov

Andy Beshear  
GOVERNOR

Jim Gray  
SECRETARY

## Asbestos Inspection Report

To: Tom Mathews

District: Central Office

Date: June 20, 2022

Conducted By: O'Dail Lawson

Report Prepared By: O'Dail Lawson

---

### Project and Structure Identification

Project Number: CID 222969

Structure ID: 075B00074N

Structure Location: KY-0081 over Cypress Creek

Sample Description: There were no suspect materials present on this structure.

Inspection Date: June 14, 2022

### Results and Recommendations

There were no suspect materials observed during this inspection; No samples collected.

\*\*\* It is recommended that this report accompany the 10-Day Notice of Intent for Demolition ([Notification Form DEP 7036](#)) which is to be submitted to the Kentucky Division of Air Quality prior to abatement, demolition, or renovation of any building or structure in the Commonwealth.

**ENVIRONMENTAL TRAINING CONCEPTS, INC**

P.O Box 99603 Louisville, KY 40269  
(502)640-2951

Certification Number: ETC-AIR-031522-00137

**O'Dail Lawson**

has on 03-15-2022, attended and successfully completed the requirements and passed the examination with a score of 70% of better on the entitled course.

**ASBESTOS INSPECTOR REFRESHER**

Training was in accordance with 40 CFR Part 763 (AHERA) approved by the Commonwealth of Kentucky, the Indiana Department of Environmental Management, Tennessee Department of Environment & Conservation and The Arkansas Department of Environmental Quality. The above student received requisite training for Asbestos Accreditation under Title II of the Toxic Substance Act (TSCA).

Conducted at: 1220 KY Mills Drive, Louisville, KY

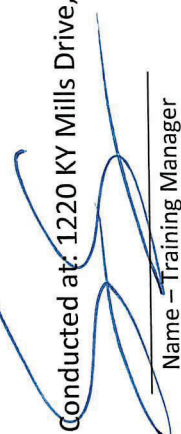
  
Name - Training Manager

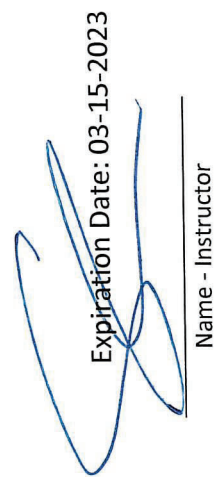
  
Expiration Date: 03-15-2023  
Name - Instructor



COMMONWEALTH OF KENTUCKY  
TRANSPORTATION CABINET  
transportation.ky.gov

Andy Beshear  
GOVERNOR

Jim Gray  
SECRETARY

## Asbestos Inspection Report

To: Tom Mathews

District: 2

Date: June 20, 2022

Conducted By: O'Dail Lawson

Report Prepared By: O'Dail Lawson

---

### Project and Structure Identification

Project Number: CID 222969

Structure ID: McClean 075B00070N

Structure Location: KY – 85 over Cypress Creek

Sample Description: Any suspect materials collected were negative for asbestos.

Inspection Date: June 14<sup>th</sup>, 2022

### Results and Recommendations

The results of the samples collected were negative for the presence of asbestos above 1%.  
No abatement is required at this time.

It is recommended that this report accompany the 10-Day Notice of Intent for Demolition ([Notification Form DEP 7036](#)) which is to be submitted to the Kentucky Division of Air Quality prior to abatement, demolition, or renovation of any building or structure in the Commonwealth.





*MRS, Inc. Analytical Laboratory Division*

332 West Broadway / Suite # 902  
 Louisville, Kentucky - 40202 - 2133

(502) 495-1212

Fax: (502) 491-7111

**BULK SAMPLE ASBESTOS ANALYSIS**

Analysis N# # 3206183 Address: McLean County 075 B00070N  
 Client Name: K Y T C  
 Sampled By: O'Dail Lawson

Sample ID	Color	Layered	Fibrous	% FIBROUS ASBESTOS				% NON-ASBESTOS FIBERS			
				Chrysotile	Amosite	crocidolite	Others	Cellulose	Fiberglass	Syn. Fiber	Other/Mat.
# 70-1	Black	Yes	No				None				100%
# 70-2	<b>Black</b>	Yes	No				None				100%

Methodology : EPA Method 600/R-93-116  
 Date Analyzed : 18-Jun-22  
 Analyst : Winterford Mensah

Reviewed By:   
Signature

The test relates only to the items tested. This report does not represent endorsement by NVLAP or any agency of the U.S Government. Partial Reproduction of any part of this report is strictly prohibited. Samples shall be retained for (30) days.

AIHA # 102459

AJHA #1 02459



# Chain of Custody Record

## Kentucky Transportation Cabinet

200 Mero Street, 5th Floor West  
Frankfort, Kentucky 40622  
(502) 564-7250 fax (502) 564-5655

O'Dail Lawson [odail.lawson@ky.gov](mailto:odail.lawson@ky.gov)  
W4-06-06

Address: 200 Mero Street  
Frankfort KY

Phone: 502-782-5020 Fax: 502-564-5655

PO#:

Client Information KY TRANSPORTATION CABINET

Results Code:

N/A = Not Applicable

*KY-85 over Cypress Creek*

Samplers (signature):

*[Signature]*

Project ID *McLean 075B00070N*

Sample ID	Sample Description	Collected		Analysis Requested	Matrix	Color	Cont. Type	Preservative
		Date	Time					
70-1	Joint Compound	6/14/22	11:57	Asbestos Bulk	Rubber	White		N/A
70-2	Joint Sealant				bituminous black			

Relinquished By: \_\_\_\_\_ Date/Time: \_\_\_\_\_

Received By: *[Signature]* Date/Time: *6/14/22*

Relinquished By: \_\_\_\_\_ Date/Time: \_\_\_\_\_

Received at Lab By: \_\_\_\_\_ Date/Time: \_\_\_\_\_

**ENVIRONMENTAL TRAINING CONCEPTS, INC**

P.O Box 99603 Louisville, KY 40269  
(502)640-2951

Certification Number: ETC-AIR-031522-00137

**O'Dail Lawson**

has on 03-15-2022, attended and successfully completed the requirements and passed the examination with a score of 70% of better on the entitled course.

**ASBESTOS INSPECTOR REFRESHER**

Training was in accordance with 40 CFR Part 763 (AHERA) approved by the Commonwealth of Kentucky, the Indiana Department of Environmental Management, Tennessee Department of Environment & Conservation and The Arkansas Department of Environmental Quality. The above student received requisite training for Asbestos Accreditation under Title II of the Toxic Substance Act (TSCA).

Conducted at: 1220 KY Mills Drive, Louisville, KY

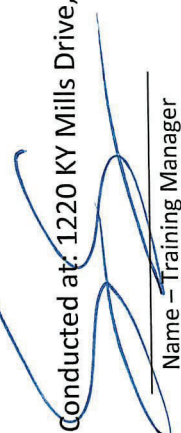
  
Name - Training Manager

Expiration Date: 03-15-2023

  
Name - Instructor



COMMONWEALTH OF KENTUCKY  
TRANSPORTATION CABINET  
transportation.ky.gov

Andy Beshear  
GOVERNOR

Jim Gray  
SECRETARY

## Asbestos Inspection Report

To: Tom Mathews

District: 2

Date: June 20, 2022

Conducted By: O'Dail Lawson

Report Prepared By: O'Dail Lawson

---

### Project and Structure Identification

Project Number: CID 222969

Structure ID: Muhlenberg 089B00110N

Structure Location: KY – 189 (Robert Draper Way) over a field

Sample Description: Any suspect materials collected were negative for asbestos.

Inspection Date: June 14<sup>th</sup>, 2022

### Results and Recommendations

The results of the samples collected were negative for the presence of asbestos above 1%.  
No abatement is required at this time.

It is recommended that this report accompany the 10-Day Notice of Intent for Demolition ([Notification Form DEP 7036](#)) which is to be submitted to the Kentucky Division of Air Quality prior to abatement, demolition, or renovation of any building or structure in the Commonwealth.

***MRS, INC.*** *MRS, Inc. Analytical Laboratory Division*

332 West Broadway / Suite # 902  
Louisville, Kentucky - 40202 - 2133

(502) 495-1212  
Fax: (502) 491-7111

**BULK SAMPLE ASBESTOS ANALYSIS**

Analysis N#      # 3206184      Address: Muhlenberg County 089 B00110N  
Client Name:      K Y T C  
Sampled By:      O'Dail Lawson

Sample ID	Color	Layered	Fibrous	% FIBROUS ASBESTOS				% NON-ASBESTOS FIBERS			
				Chrysotile	Amosite	crocidolite	Others	Cellulose	Fiberglass	Syn. Fiber	Other/Mat.
# 110-1	Black	Yes	No				None				100%

Methodology : EPA Method 600/R-93-116  
Date Analyzed : 18-Jun-22  
Analyst : Winterford Mensah

Reviewed By: *Winterford Mensah*  
Signature

The test relates only to the items tested. This report does not represent endorsement by NVLAP or any agency of the U.S Government. Partial Reproduction of any part of this report is strictly prohibited. Samples shall be retained for (30) days.

# Chain of Custody Record

## Kentucky Transportation Cabinet

200 Mero Street, 5th Floor West  
Frankfort, Kentucky 40622  
(502) 564-7250 fax (502) 564-5655



O'Dail Lawson [o'dail.lawson@ky.gov](mailto:o'dail.lawson@ky.gov)

W4-06-06

Address: 200 Mero Street

Frankfort KY

Phone: 502-782-5020

PO#: Fax: 502-564-5655

Project ID

Muhlenberg

081B00110N

Client Information KY TRANSPORTATION CABINET

Results Code: KY-189 over field.

N/A = Not Applicable

Samplers (signature):

*[Signature]*

Sample ID	Sample Description	Collected		Analysis Requested	Matrix	Color	Cont. Type	Preservative
		Date	Time					
110-1	Joints Compounds	6/14/22	13:33	Asbestos bulk	Ribbe	White		N/A

Relinquished By:	Date/Time:
Received By: <i>[Signature]</i>	Date/Time: 6/14/22
Relinquished By:	Date/Time:
Received at Lab By:	Date/Time:

KYTC COC

**ENVIRONMENTAL TRAINING CONCEPTS, INC**

P.O Box 99603 Louisville, KY 40269  
(502)640-2951

Certification Number: ETC-AIR-031522-00137

**O'Dail Lawson**

has on 03-15-2022, attended and successfully completed the requirements and passed the examination with a score of 70% of better on the entitled course.

**ASBESTOS INSPECTOR REFRESHER**

Training was in accordance with 40 CFR Part 763 (AHERA) approved by the Commonwealth of Kentucky, the Indiana Department of Environmental Management, Tennessee Department of Environment & Conservation and The Arkansas Department of Environmental Quality. The above student received requisite training for Asbestos Accreditation under Title II of the Toxic Substance Act (TSCA).

Conducted at: 1220 KY Mills Drive, Louisville, KY

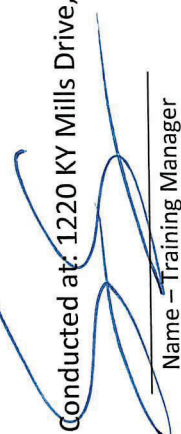
  
Name - Training Manager

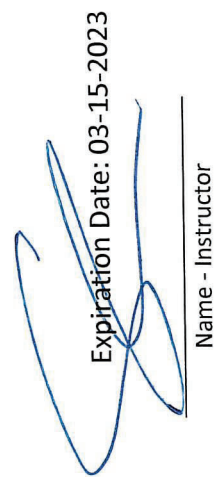
  
Expiration Date: 03-15-2023  
Name - Instructor



COMMONWEALTH OF KENTUCKY  
TRANSPORTATION CABINET  
transportation.ky.gov

Andy Beshear  
GOVERNOR

Jim Gray  
SECRETARY

## Asbestos Inspection Report

To: Tom Mathews

District: 2

Date: June 20, 2022

Conducted By: O'Dail Lawson

Report Prepared By: O'Dail Lawson

---

### Project and Structure Identification

Project Number: CID 222969

Structure ID: Webster 117B00118N

Structure Location: KY – 109 (Broadway Street) over Owens Creek

Sample Description: Any suspect materials collected were negative for asbestos.

Inspection Date: June 14<sup>th</sup>, 2022

### Results and Recommendations

The results of the samples collected were negative for the presence of asbestos above 1%.  
No abatement is required at this time.

It is recommended that this report accompany the 10-Day Notice of Intent for Demolition ([Notification Form DEP 7036](#)) which is to be submitted to the Kentucky Division of Air Quality prior to abatement, demolition, or renovation of any building or structure in the Commonwealth.



# MRS, Inc. Analytical Laboratory Division

332 West Broadway, Suite # 902  
Louisville, Kentucky 40202

Phone # : (502) 495-1212  
E-Mail Address : CEOMRSInc@AOL.Com

<b>Client:</b>	<u>KYTC</u>	<b>Project No:</b>	<u># 3206185 B</u>
<b>Address:</b>	<u>200 Mero Street</u>	<b>Sample ID:</b>	<u># 118 - 1</u>
	<u>Frankfort, KY</u>	<b>Sampled:</b>	<u>14-Jun-22</u>
	<u>40601</u>	<b>Received:</b>	<u>14-Jun-22</u>
		<b>Analyzed:</b>	<u>18-Jun-22 - Point Count -</u>
	<u>Attention : O'Dail Lawson</u>		

Bulk Sample Analysis					
<b>Sampled By :</b>	<u>O'Dail Lawson</u>				
<b>Facility/Location:</b>	<u>Webster County - Item # 117 B00118N</u>				
<b>Field Description:</b>	<u>Guard Rail Mastic</u>				
<b>Laboratory Description:</b>	<u>Thick Gray Material</u>				
<b>Asbestos Materials:</b>	<u>Chrysotile = 2/400 = 0.50 % ( &lt; 1 % ) Sample Is Negative</u>				
<b>Non-Asbestos Fibrous Materials :</b>	<table border="0"> <tr> <td><u>Cellulose</u></td> <td><u>0.25 %</u></td> </tr> <tr> <td><u>Binders</u></td> <td><u>99.25 %</u></td> </tr> </table>	<u>Cellulose</u>	<u>0.25 %</u>	<u>Binders</u>	<u>99.25 %</u>
<u>Cellulose</u>	<u>0.25 %</u>				
<u>Binders</u>	<u>99.25 %</u>				
<b>Remarks:</b> The sample was analyzed for asbestos content following the EPA Methodology (600/R-93/116). The test relates only to the items tested. This report does not represent endorsement by NVLAP or any agency of the U.S. Government.					
<b>Analyst:</b> <u>Winterford Mensah</u>	<b>Reviewed By:</b> <u></u> Signature				

**MRS, INC.** MRS, Inc. Analytical Laboratory Division

332 West Broadway / Suite # 902  
Louisville, Kentucky - 40202 - 2133

(502) 495-1212  
Fax: (502) 491-7111

**BULK SAMPLE ASBESTOS ANALYSIS**

Analysis N# # 3206185 Address: Webster County - 117 B00118N  
Client Name: K Y T C  
Sampled By: O'Dail Lawson

Table with 12 columns: Sample ID, Color, Layered, Fibrous, % FIBROUS ASBESTOS (Chrysotile, Amosite, crocidolite, Others), % NON-ASBESTOS FIBERS (Cellulose, Fiberglass, Syn. Fiber, Other/Mat.). Row 1: # 118-1, Gray, Yes, No, 3% (To Be Point Counted), 2%, 95%.

Methodology : EPA Method 600/R-93-116

Date Analyzed : 18-Jun-22

Analyst : Winterford Mensah

Reviewed By: Winterford Mensah  
Signature

The test relates only to the items tested. This report does not represent endorsement by NVLAP or any agency of the U.S Government. Partial Reproduction of any part of this report is strictly prohibited. Samples shall be retained for (30) days.

AIHA # 102459

AJHA #1 02459



# Chain of Custody Record

## Kentucky Transportation Cabinet

200 Mero Street, 5th Floor West  
 Frankfort, Kentucky 40622  
 (502) 564-7250 fax (502) 564-5655

O'Dail Lawson <a href="mailto:odail.lawson@ky.gov">odail.lawson@ky.gov</a> W4-06-06 Address: 200 Mero Street Frankfort KY Phone: 502-782-5020 Fax: 502-564-5655 PO#: N/A = Not Applicable	<b>Client Information</b> KY TRANSPORTATION CABINET Results Code: <i>KY-109 over Owens Crsch.</i>	Project ID <i>Webster 117B00018N</i> Samplers (signature):
--	--	---

Sample ID	Sample Description	Collected		Analysis Requested	Matrix	Color	Cont. Type	Preservative
		Date	Time					
118-1	<i>Guano Rail Mastic</i>	<i>6/14/22</i>	<i>10:36</i>	<i>Asberry bulk</i>	<i>MARL</i>	<i>grey</i>		<i>N/A</i>

Relinquished By:	Date/Time:
Received By: <i>Matthews</i>	Date/Time: <i>6/14/22</i>
Relinquished By:	Date/Time:
Received at Lab By:	Date/Time:

**ENVIRONMENTAL TRAINING CONCEPTS, INC**

P.O Box 99603 Louisville, KY 40269  
(502)640-2951

Certification Number: ETC-AIR-031522-00137

**O'Dail Lawson**

has on 03-15-2022, attended and successfully completed the requirements and passed the examination with a score of 70% of better on the entitled course.

**ASBESTOS INSPECTOR REFRESHER**

Training was in accordance with 40 CFR Part 763 (AHERA) approved by the Commonwealth of Kentucky, the Indiana Department of Environmental Management, Tennessee Department of Environment & Conservation and The Arkansas Department of Environmental Quality. The above student received requisite training for Asbestos Accreditation under Title II of the Toxic Substance Act (TSCA).

Conducted at: 1220 KY Mills Drive, Louisville, KY

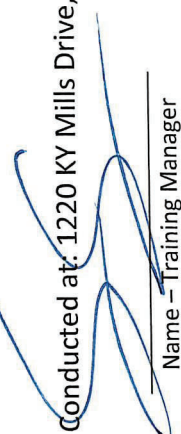
  
Name - Training Manager

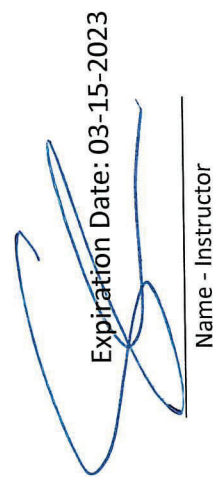
  
Expiration Date: 03-15-2023  
Name - Instructor

# MATERIAL SUMMARY

**CONTRACT ID: 222969**

**121GR22M054 - FE02**

**MB054041A2201**

NEBO ROAD (US 41A) BRIDGE 054B00208N OVER POND CREEK AT MP 06.78 BRIDGE DECK RESTORATION & WATERPROOFING.

Project Line No	Bid Code	DESCRIPTION	Quantity	Unit
0005	02562	TEMPORARY SIGNS - - 054B00208N	145.00	SQFT
0010	02650	MAINTAIN & CONTROL TRAFFIC - - 054B00208N	1.00	LS
0015	02653	LANE CLOSURE - - 054B00208N	2.00	EACH
0020	03294	EXPAN JOINT REPLACE 1 1/2 IN - - 054B00208N	92.20	LF
0025	03304	BRIDGE OVERLAY APPROACH PAVEMENT - - 054B00208N	1,011.00	SQYD
0030	04933	TEMP SIGNAL 2 PHASE - - 054B00208N	1.00	EACH
0035	06514	PAVE STRIPING-PERM PAINT-4 IN - - 054B00208N	780.00	LF
0040	06549	PAVE STRIPING-TEMP REM TAPE-B - - 054B00208N	1,000.00	LF
0045	06550	PAVE STRIPING-TEMP REM TAPE-W - - 054B00208N	2,000.00	LF
0050	06551	PAVE STRIPING-TEMP REM TAPE-Y - - 054B00208N	2,000.00	LF
0055	08150	STEEL REINFORCEMENT - - 054B00208N	270.00	LB
0060	08504	EPOXY SAND SLURRY - - 054B00208N	30.00	SQYD
0065	08526	CONC CLASS M FULL DEPTH PATCH - - 054B00208N	1.00	CUYD
0070	08534	CONCRETE OVERLAY-LATEX - - 054B00208N	23.40	CUYD
0075	08549	BLAST CLEANING - - 054B00208N	591.00	SQYD
0080	08551	MACHINE PREP OF SLAB - - 054B00208N	561.00	SQYD
0085	24094EC	PARTIAL DEPTH PATCHING - - 054B00208N	11.70	CUYD
0090	02569	DEMOBILIZATION	1.00	LS

# MATERIAL SUMMARY

**CONTRACT ID: 222969**

**121GR22M054 - FE02**

**MB07500812201**

SACRAMENTO - RUMSEY ROAD (KY 81) BRIDGE 075B00074N OVER CYPRESS CREEK AT MP 08.37 BRIDGE DECK RESTORATION & WATERPROOFING.

Project Line No	Bid Code	DESCRIPTION	Quantity	Unit
0180	02562	TEMPORARY SIGNS - - 075B00074N	145.00	SQFT
0185	02650	MAINTAIN & CONTROL TRAFFIC - - 075B00074N	1.00	LS
0190	02653	LANE CLOSURE - - 075B00074N	2.00	EACH
0195	03299	ARMORED EDGE FOR CONCRETE - - 075B00074N	55.00	LF
0200	03304	BRIDGE OVERLAY APPROACH PAVEMENT - - 075B00074N	612.00	SQYD
0205	04933	TEMP SIGNAL 2 PHASE - - 075B00074N	1.00	EACH
0210	06514	PAVE STRIPING-PERM PAINT-4 IN - - 075B00074N	678.00	LF
0215	06549	PAVE STRIPING-TEMP REM TAPE-B - - 075B00074N	1,000.00	LF
0220	06550	PAVE STRIPING-TEMP REM TAPE-W - - 075B00074N	2,000.00	LF
0225	06551	PAVE STRIPING-TEMP REM TAPE-Y - - 075B00074N	2,000.00	LF
0230	08150	STEEL REINFORCEMENT - - 075B00074N	270.00	LB
0235	08504	EPOXY SAND SLURRY - - 075B00074N	38.00	SQYD
0240	08526	CONC CLASS M FULL DEPTH PATCH - - 075B00074N	1.00	CUYD
0245	08534	CONCRETE OVERLAY-LATEX - - 075B00074N	16.80	CUYD
0250	08549	BLAST CLEANING - - 075B00074N	442.00	SQYD
0255	08551	MACHINE PREP OF SLAB - - 075B00074N	404.00	SQYD
0260	24094EC	PARTIAL DEPTH PATCHING - - 075B00074N	8.40	CUYD
0265	02569	DEMOBILIZATION	1.00	LS

# MATERIAL SUMMARY

**CONTRACT ID: 222969**

**121GR22M054 - FE02**

**MB07500852201**

SACRAMENTO - ISLAND ROAD (KY 85) BRIDGE 075B00070N OVER CYPRESS CREEK AT MP 06.82 BRIDGE DECK RESTORATION & WATERPROOFING.

Project Line No	Bid Code	DESCRIPTION	Quantity	Unit
0095	02562	TEMPORARY SIGNS - - 075B00070N	145.00	SQFT
0100	02650	MAINTAIN & CONTROL TRAFFIC - - 075B00070N	1.00	LS
0105	02653	LANE CLOSURE - - 075B00070N	2.00	EACH
0110	03294	EXPAN JOINT REPLACE 1 1/2 IN - - 075B00070N	67.00	LF
0115	03304	BRIDGE OVERLAY APPROACH PAVEMENT - - 075B00070N	745.00	SQYD
0120	04933	TEMP SIGNAL 2 PHASE - - 075B00070N	1.00	EACH
0125	06514	PAVE STRIPING-PERM PAINT-4 IN - - 075B00070N	514.00	LF
0130	06549	PAVE STRIPING-TEMP REM TAPE-B - - 075B00070N	1,000.00	LF
0135	06550	PAVE STRIPING-TEMP REM TAPE-W - - 075B00070N	2,000.00	LF
0140	06551	PAVE STRIPING-TEMP REM TAPE-Y - - 075B00070N	2,000.00	LF
0145	08150	STEEL REINFORCEMENT - - 075B00070N	270.00	LB
0150	08504	EPOXY SAND SLURRY - - 075B00070N	42.00	SQYD
0155	08534	CONCRETE OVERLAY-LATEX - - 075B00070N	23.70	CUYD
0160	08549	BLAST CLEANING - - 075B00070N	610.00	SQYD
0165	08551	MACHINE PREP OF SLAB - - 075B00070N	568.00	SQYD
0170	24094EC	PARTIAL DEPTH PATCHING - - 075B00070N	11.80	CUYD
0175	02569	DEMOBILIZATION	1.00	LS

# MATERIAL SUMMARY

**CONTRACT ID: 222969**

**121GR22M054 - FE02**

**MB08901892201**

ROBERT L. DRAPER WAY (KY 189) BRIDGE 089B00110N OVER FIELD AT MP 10.00 BRIDGE DECK RESTORATION & WATERPROOFING.

Project Line No	Bid Code	DESCRIPTION	Quantity	Unit
0270	02562	TEMPORARY SIGNS - - 089B00110N	145.00	SQFT
0275	02650	MAINTAIN & CONTROL TRAFFIC - - 089B00110N	1.00	LS
0280	02653	LANE CLOSURE - - 089B00110N	2.00	EACH
0285	03294	EXPAN JOINT REPLACE 1 1/2 IN - - 089B00110N	91.20	LF
0290	03299	ARMORED EDGE FOR CONCRETE - - 089B00110N	91.20	LF
0295	03304	BRIDGE OVERLAY APPROACH PAVEMENT - - 089B00110N	1,011.00	SQYD
0300	04933	TEMP SIGNAL 2 PHASE - - 089B00110N	1.00	EACH
0305	06514	PAVE STRIPING-PERM PAINT-4 IN - - 089B00110N	730.00	LF
0310	06549	PAVE STRIPING-TEMP REM TAPE-B - - 089B00110N	1,000.00	LF
0315	06550	PAVE STRIPING-TEMP REM TAPE-W - - 089B00110N	2,000.00	LF
0320	06551	PAVE STRIPING-TEMP REM TAPE-Y - - 089B00110N	2,000.00	LF
0325	08150	STEEL REINFORCEMENT - - 089B00110N	270.00	LB
0330	08504	EPOXY SAND SLURRY - - 089B00110N	97.00	SQYD
0335	08526	CONC CLASS M FULL DEPTH PATCH - - 089B00110N	1.00	CUYD
0340	08534	CONCRETE OVERLAY-LATEX - - 089B00110N	34.20	CUYD
0345	08549	BLAST CLEANING - - 089B00110N	917.00	SQYD
0350	08551	MACHINE PREP OF SLAB - - 089B00110N	820.00	SQYD
0355	24094EC	PARTIAL DEPTH PATCHING - - 089B00110N	17.10	CUYD
0360	02569	DEMOBILIZATION	1.00	LS



# MATERIAL SUMMARY

**CONTRACT ID: 222969**

**121GR22M054 - FE02**

**MB11701092201**

SOUTH BROADWAY STREET (KY 109) BRIDGE 117B00118N OVER OWENS CREEK AT MP 01.07 BRIDGE DECK RESTORATION & WATERPROOFING.

Project Line No	Bid Code	DESCRIPTION	Quantity	Unit
0365	02562	TEMPORARY SIGNS - - 117B00118N	145.00	SQFT
0370	02650	MAINTAIN & CONTROL TRAFFIC - - 117B00118N	1.00	LS
0375	02653	LANE CLOSURE - - 117B00118N	2.00	EACH
0380	03299	ARMORED EDGE FOR CONCRETE - - 117B00118N	80.80	LF
0385	04933	TEMP SIGNAL 2 PHASE - - 117B00118N	1.00	EACH
0390	06514	PAVE STRIPING-PERM PAINT-4 IN - - 117B00118N	64.00	LF
0395	06549	PAVE STRIPING-TEMP REM TAPE-B - - 117B00118N	1,000.00	LF
0400	06550	PAVE STRIPING-TEMP REM TAPE-W - - 117B00118N	2,000.00	LF
0405	06551	PAVE STRIPING-TEMP REM TAPE-Y - - 117B00118N	2,000.00	LF
0410	08150	STEEL REINFORCEMENT - - 117B00118N	270.00	LB
0415	08504	EPOXY SAND SLURRY - - 117B00118N	39.00	SQYD
0420	08510	REM EPOXY BIT FOREIGN OVERLAY - - 117B00118N	107.00	SQYD
0425	08534	CONCRETE OVERLAY-LATEX - - 117B00118N	4.40	CUYD
0430	08549	BLAST CLEANING - - 117B00118N	146.00	SQYD
0435	24094EC	PARTIAL DEPTH PATCHING - - 075B00070N	2.20	CUYD
0440	02569	DEMOBILIZATION	1.00	LS

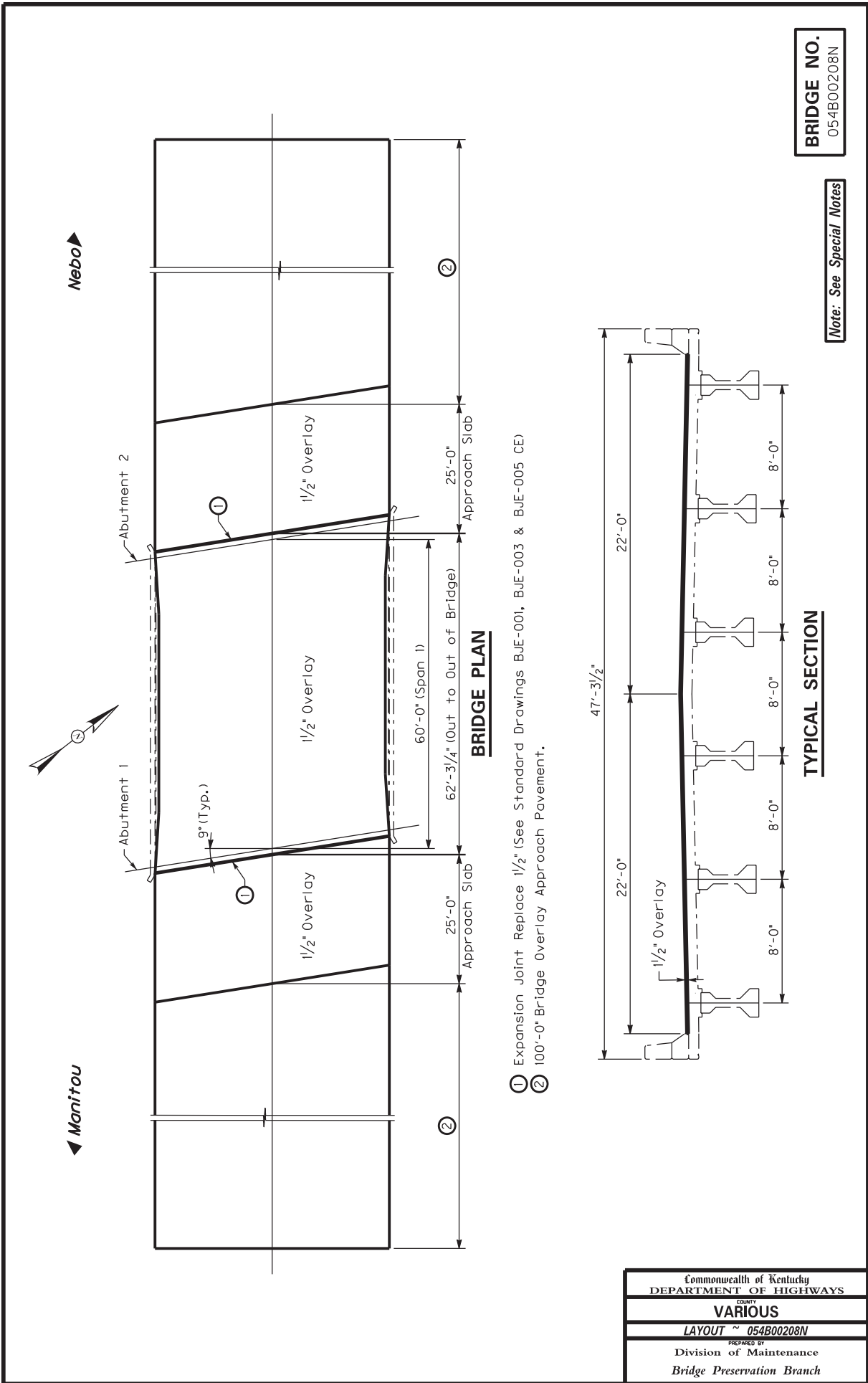

**BRIDGE PLAN**

**TYPICAL SECTION**

- ① Expansion Joint Replace 1/2" (See Standard Drawings BJE-001, BJE-003 & BJE-005 CE)
- ② 100'-0" Bridge Overlay Approach Pavement.

**BRIDGE NO.**  
054B00208N

**Note: See Special Notes**

Commonwealth of Kentucky DEPARTMENT OF HIGHWAYS
COUNTY <b>VARIOUS</b>
LAYOUT ~ 054B00208N
PREPARED BY Division of Maintenance Bridge Preservation Branch

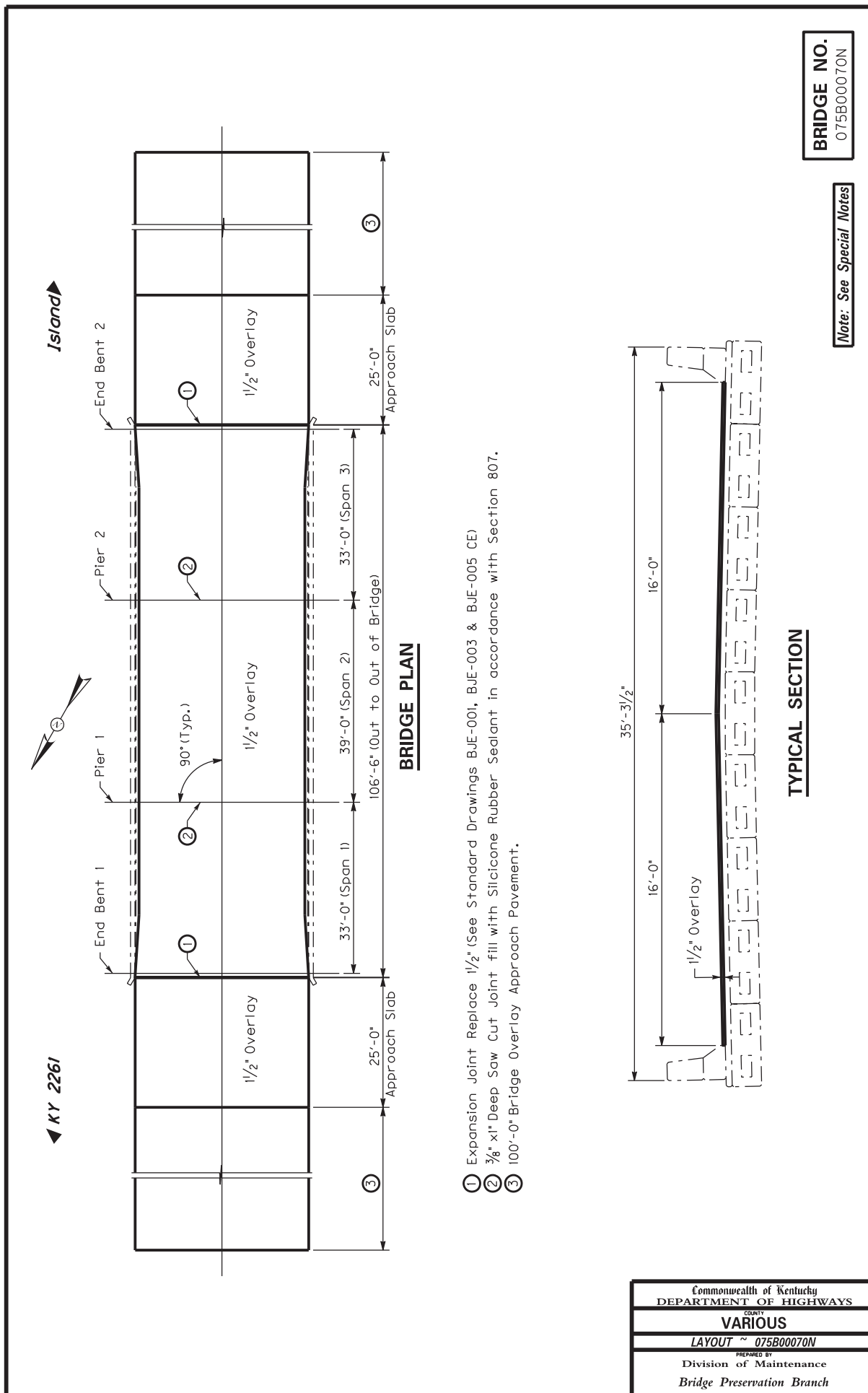

- ① Expansion Joint Replace 1/2" (See Standard Drawings BJE-001, BJE-003 & BJE-005 CE)
- ② 3/8" x 1" Deep Saw Cut Joint fill with Silicone Rubber Sealant in accordance with Section 807.
- ③ 100'-0" Bridge Overlay Approach Pavement.

**BRIDGE NO.**  
 075B00070N

**Note: See Special Notes**

Commonwealth of Kentucky DEPARTMENT OF HIGHWAYS	
COUNTY <b>VARIOUS</b>	
LAYOUT ~ 075B00070N	
PREPARED BY Division of Maintenance Bridge Preservation Branch	

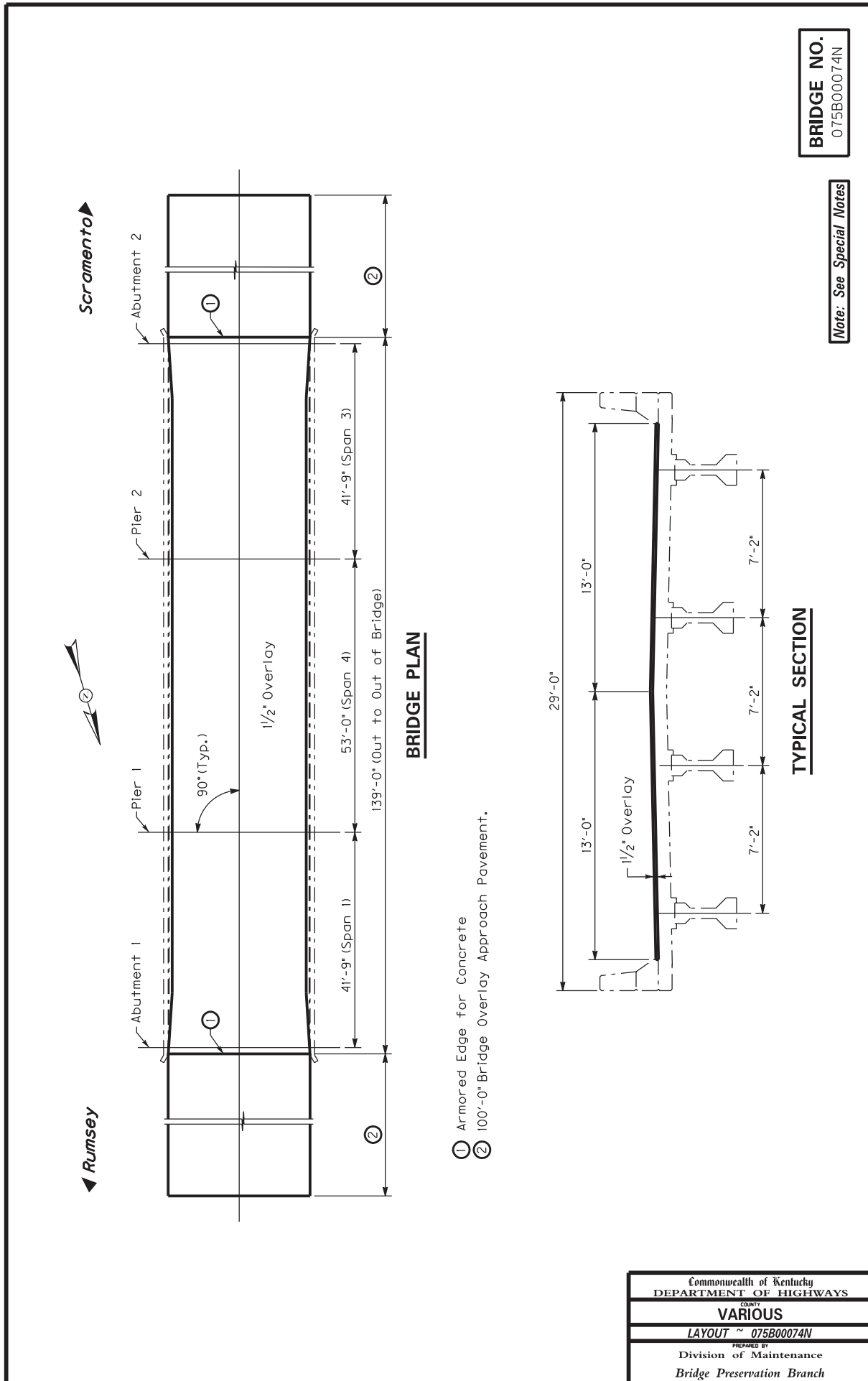

**BRIDGE PLAN**

**TYPICAL SECTION**

- ① Armored Edge for Concrete
- ② 100'-0" Bridge Overlay Approach Pavement.

**BRIDGE NO.**  
 075B00074N

**Note: See Special Notes**

Commonwealth of Kentucky DEPARTMENT OF HIGHWAYS
COUNTY <b>VARIOUS</b>
LAYOUT ~ 075B00074N
PREPARED BY Division of Maintenance Bridge Preservation Branch

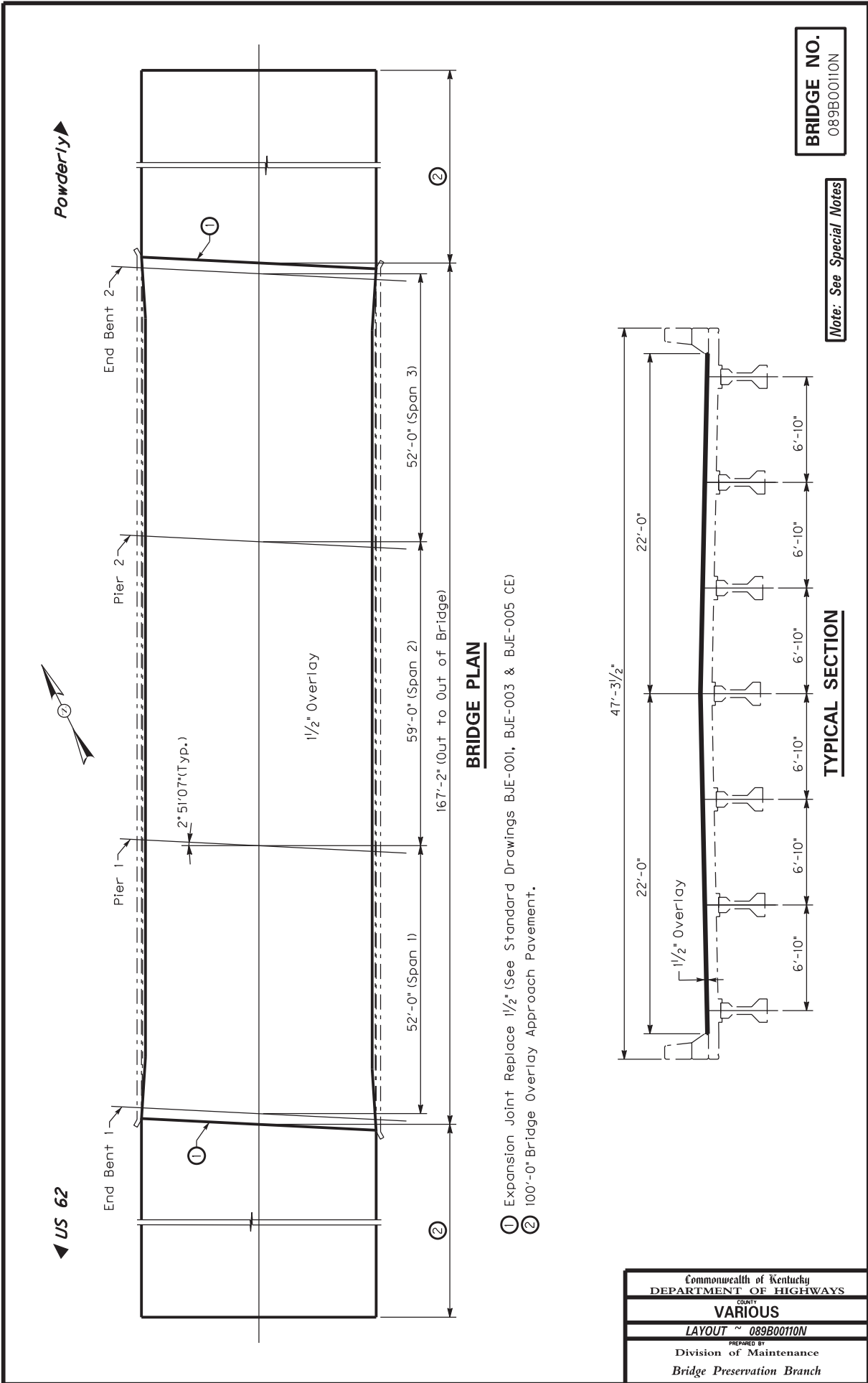

**BRIDGE PLAN**

- ① Expansion Joint Replace 1/2" (See Standard Drawings BJE-001, BJE-003 & BJE-005 CE)
- ② 100'-0" Bridge Overlay Approach Pavement.

Note: See Special Notes

BRIDGE NO.  
 089B00110N

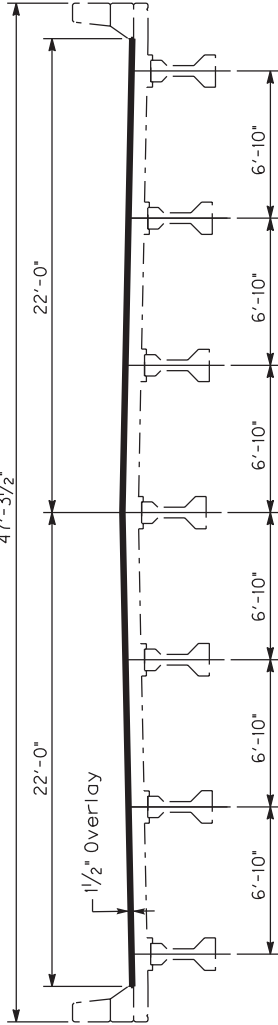

**TYPICAL SECTION**

Commonwealth of Kentucky DEPARTMENT OF HIGHWAYS	
COUNTY <b>VARIOUS</b>	
LAYOUT ~ 089B00110N	
PREPARED BY Division of Maintenance Bridge Preservation Branch	

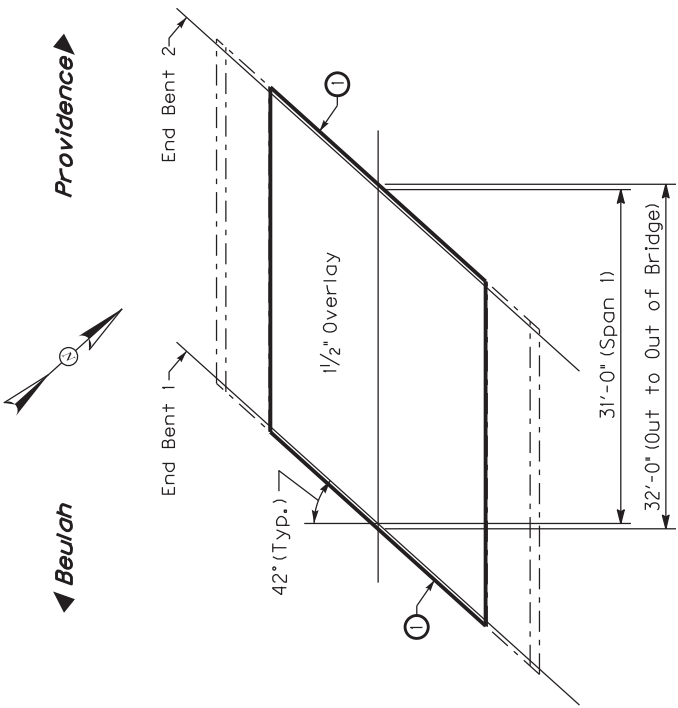

**BRIDGE PLAN**

① Armored Edge for Concrete. See Standard Drawings BJE-001 and BJE-005.

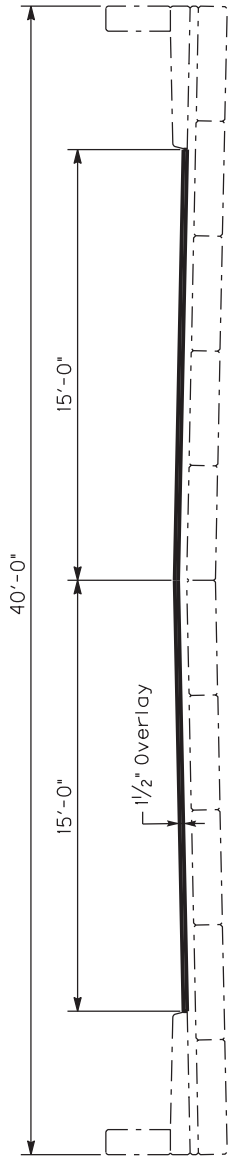

**TYPICAL SECTION**

**BRIDGE NO.**  
 117B00118N

**Note: See Special Notes**

Commonwealth of Kentucky DEPARTMENT OF HIGHWAYS
COUNTY <b>VARIOUS</b>
LAYOUT ~ 117B00118N
PREPARED BY Division of Maintenance Bridge Preservation Branch

Note: Do not damage  
 Existing Reinforcement

Remove X-Hatched Areas of Existing  
 Concrete & Amored Edge

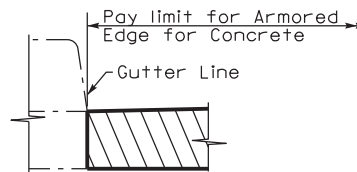
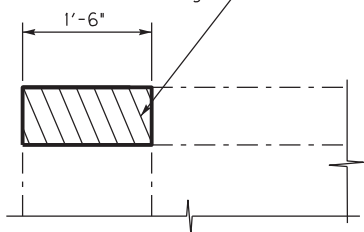

Note: See Standard Drawings  
 BJE-001 and BJE-005 for  
 Additional Notes and Details.

**SECTION THROUGH SLAB END**

Existing

**SECTION THROUGH PAPAPET**

(Existing)

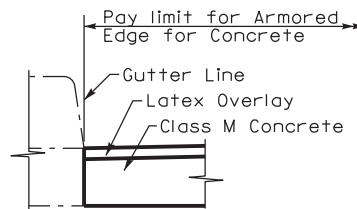
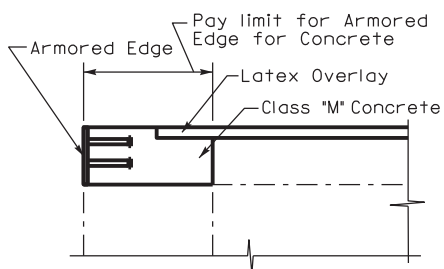

**SECTION THROUGH SLAB END**

Proposed

**SECTION THROUGH PAPAPET**

(Proposed)

**ARMORED EDGE FOR CONCRETE**

**BRIDGE NO.**  
 075B00074N  
 117B00118N

*Note: See Special Notes*

Commonwealth of Kentucky DEPARTMENT OF HIGHWAYS
COUNTY VARIOUS
ARMORED EDGE FOR CONCRETE
PREPARED BY Division of Maintenance Bridge Preservation Branch

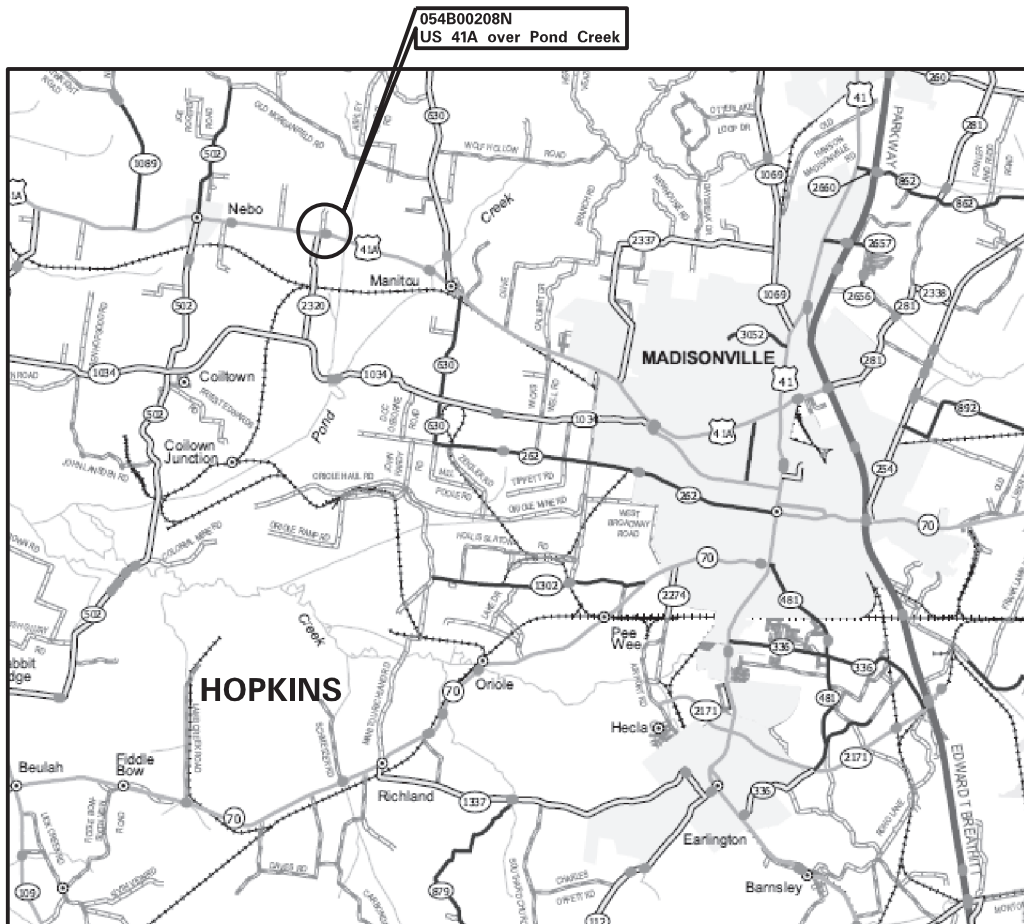

**LOCATION MAP ~ HOPKINS COUNTY**

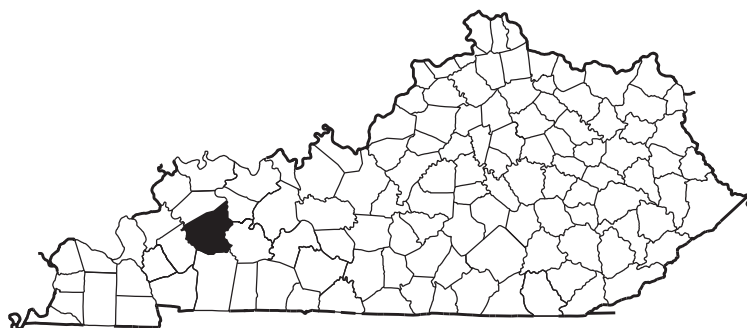

Commonwealth of Kentucky DEPARTMENT OF HIGHWAYS
COUNTY <b>VARIOUS</b>
<b>LOCATION MAP</b>
PREPARED BY Division of Maintenance Bridge Preservation Branch



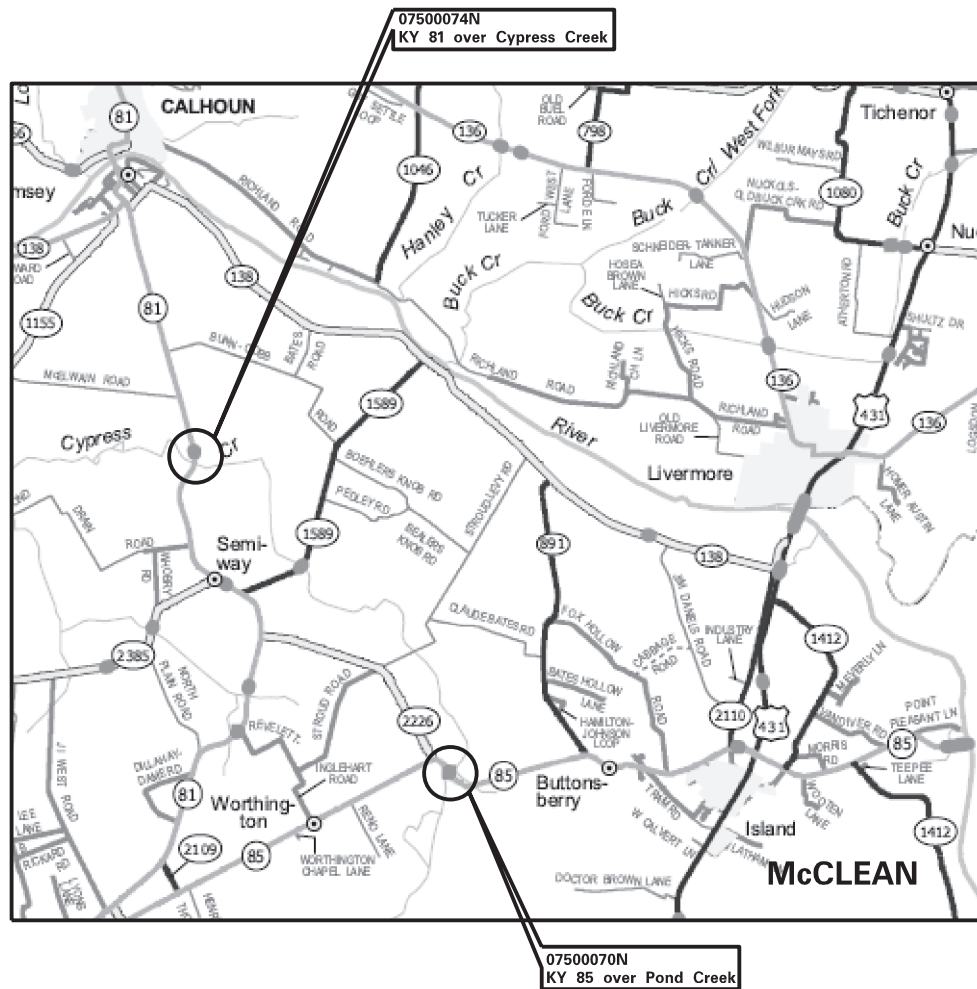

**LOCATION MAP ~ McCLEAN COUNTY**

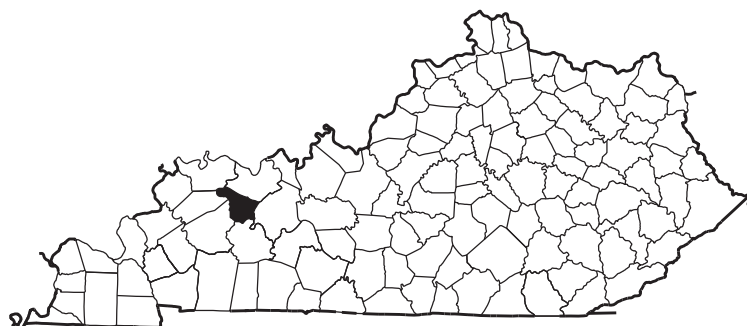

Commonwealth of Kentucky DEPARTMENT OF HIGHWAYS
COUNTY <b>VARIOUS</b>
<b>LOCATION MAP</b>
PREPARED BY Division of Maintenance Bridge Preservation Branch

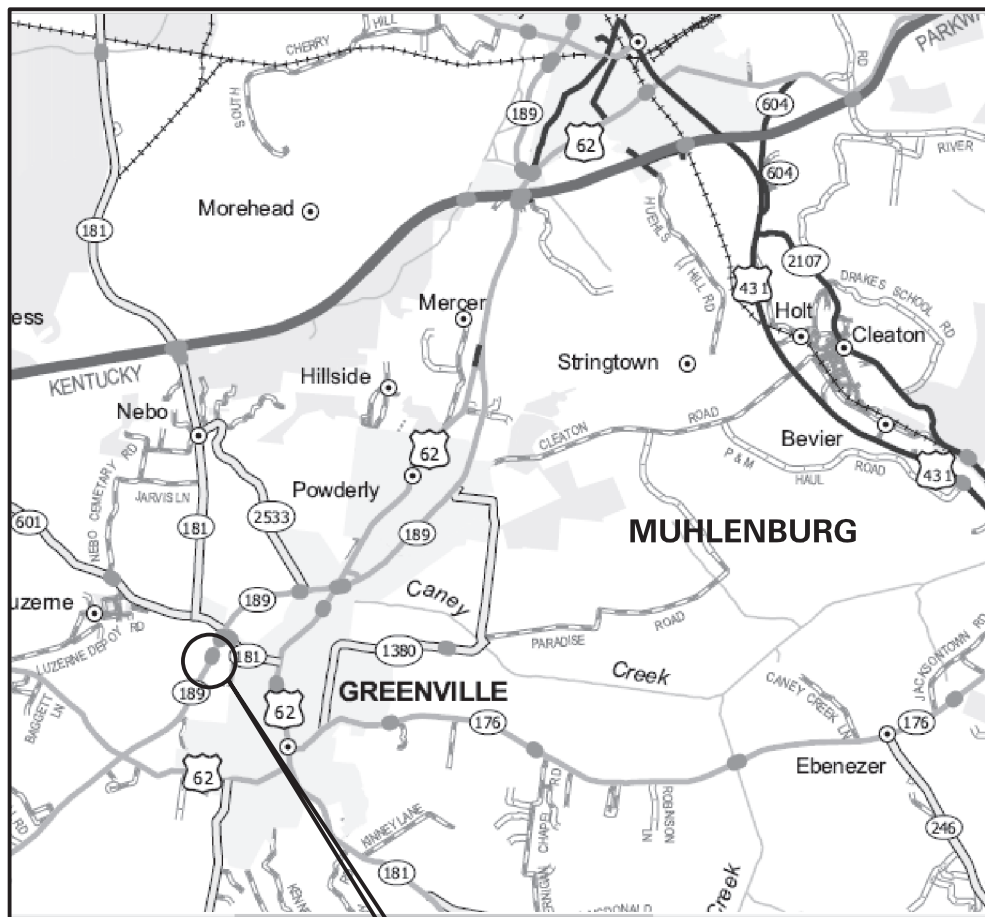

08900110N  
KY 189 over Field

**LOCATION MAP ~ MUHLENBURG COUNTY**

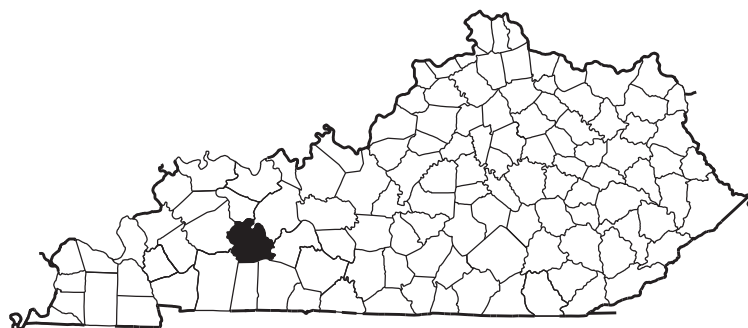

Commonwealth of Kentucky DEPARTMENT OF HIGHWAYS
COUNTY <b>VARIOUS</b>
<b>LOCATION MAP</b>
PREPARED BY Division of Maintenance Bridge Preservation Branch

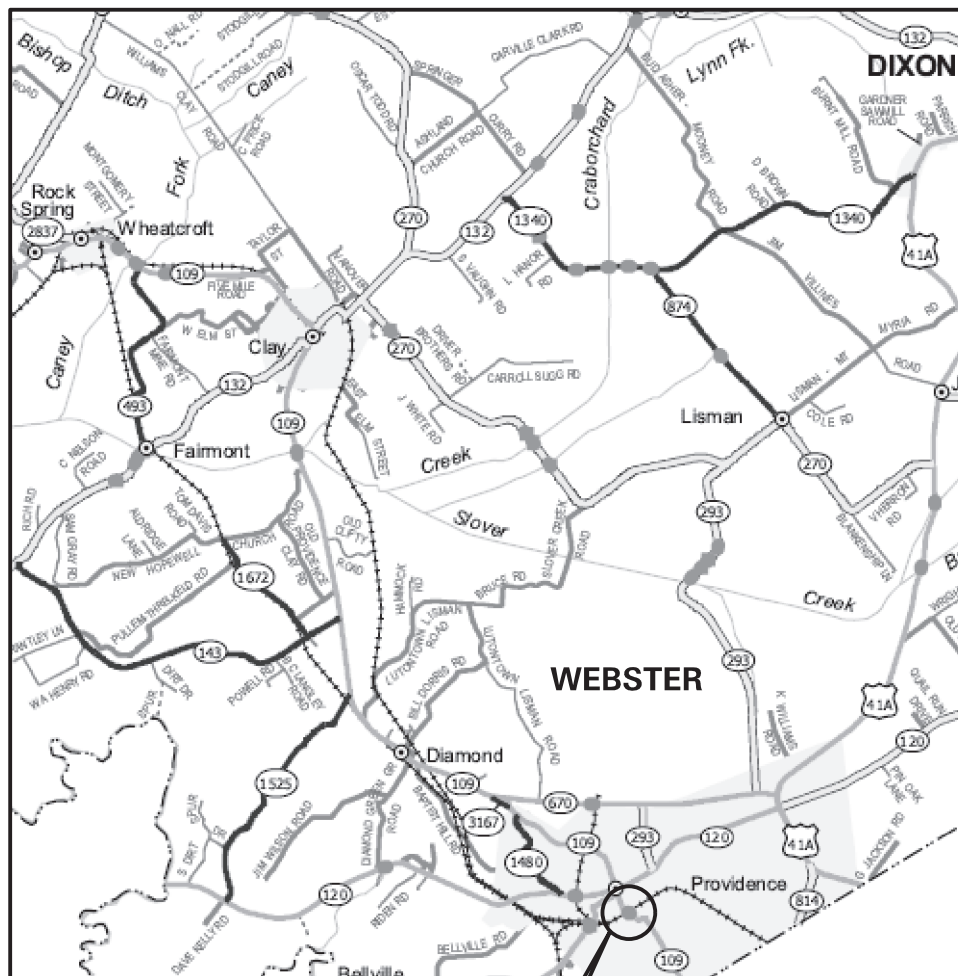

11700118N  
KY 109 over RR Ditch

**LOCATION MAP ~ WEBSTER COUNTY**

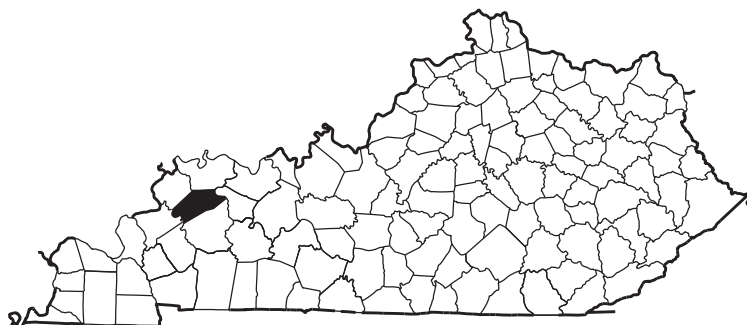

Commonwealth of Kentucky DEPARTMENT OF HIGHWAYS
COUNTY <b>VARIOUS</b>
<b>LOCATION MAP</b>
PREPARED BY Division of Maintenance Bridge Preservation Branch

**PART II**  
**SPECIFICATIONS AND STANDARD DRAWINGS**

### **SPECIFICATIONS REFERENCE**

Any reference in the plans or proposal to previous editions of the *Standard Specifications for Road and Bridge Construction* and *Standard Drawings* are superseded by *Standard Specifications for Road and Bridge Construction, Edition of 2019* and *Standard Drawings, Edition of 2020*.

## **SUPPLEMENTAL SPECIFICATIONS**

The contractor shall use the Supplemental Specifications that are effective at the time of letting.  
The Supplemental Specifications can be found at the following link:

<http://transportation.ky.gov/Construction/Pages/Kentucky-Standard-Specifications.aspx>

## STANDARD DRAWINGS THAT APPLY

### TRAFFIC ~ *TEMPORARY* ~ TRAFFIC CONTROL

LANE CLOSURE TWO LANE HIGHWAY  
LANE CLOSURE USING TRAFFIC SIGNALS

TTC-100 C.E.  
TTC-110 C.E.

### BRIDGES

#### MISCELLANEOUS STANDARDS

BRIDGE RESTORATION AND WATERPROFFING  
WITH CONCRETE OVERLAYS  
AMORED EDGES  
EXPANSION JOINT REPLACEMENT 1"-3"  
EXPANSION JOINT REPLACEMENT GENERAL NOTES

BGX-009 C.E.  
BJE-001 C.E.  
BJE-003 C.E.  
BJE-005 C.E.

## **PART III**

### **EMPLOYMENT, WAGE AND RECORD REQUIREMENTS**



**TRANSPORTATION CABINET  
DEPARTMENT OF HIGHWAYS**

**LABOR AND WAGE REQUIREMENTS  
APPLICABLE TO OTHER THAN FEDERAL-AID SYSTEM PROJECTS**

- I. Application
- II. Nondiscrimination of Employees (KRS 344)

**I. APPLICATION**

1. These contract provisions shall apply to all work performed on the contract by the contractor with his own organization and with the assistance of workmen under his immediate superintendence and to all work performed on the contract by piecework, station work or by subcontract. The contractor's organization shall be construed to include only workmen employed and paid directly by the contractor and equipment owned or rented by him, with or without operators.

2. The contractor shall insert in each of his subcontracts all of the stipulations contained in these Required Provisions and such other stipulations as may be required.

3. A breach of any of the stipulations contained in these Required Provisions may be grounds for termination of the contract.

3. If the contractor is in control of apprenticeship or other training or retraining, including on-the-job training programs, he shall not discriminate against an individual because of his race, color, religion, national origin, sex, disability or age forty (40) and over, in admission to, or employment in any program established to provide apprenticeship or other training.

4. The contractor will send to each labor union or representative of workers with which he has a collective bargaining agreement or other contract or understanding, a notice to be provided advising the said labor union or workers' representative of the contractor's commitments under this section, and shall post copies of the notice in conspicuous places available to employees and applicants for employment. The contractor will take such action with respect to any subcontract or purchase order as the administrating agency may direct as a means of enforcing such provisions, including sanctions for non-compliance.

Revised: January 25, 2017

**II. NONDISCRIMINATION OF EMPLOYEES**

**AN ACT OF THE KENTUCKY  
GENERAL ASSEMBLY TO PREVENT  
DISCRIMINATION IN EMPLOYMENT  
KRS CHAPTER 344  
EFFECTIVE JUNE 16, 1972**

The contract on this project, in accordance with KRS Chapter 344, provides that during the performance of this contract, the contractor agrees as follows:

1. The contractor shall not fail or refuse to hire, or shall not discharge any individual, or otherwise discriminate against an individual with respect to his compensation, terms, conditions, or privileges of employment, because of such individual's race, color, religion, national origin, sex, disability or age (forty and above); or limit, segregate, or classify his employees in any way which would deprive or tend to deprive an individual of employment opportunities or otherwise adversely affect his status as an employee, because of such individual's race, color, religion, national origin, sex, disability or age forty (40) and over. The contractor agrees to post in conspicuous places, available to employees and applicants for employment, notices to be provided setting forth the provisions of this nondiscrimination clause.

2. The contractor shall not print or publish or cause to be printed or published a notice or advertisement relating to employment by such an employer or membership in or any classification or referral for employment by the employment agency, indicating any preference, limitation, specification, or discrimination, based on race, color, religion, national origin, sex, or age forty (40) and over, or because the person is a qualified individual with a disability, except that such a notice or advertisement may indicate a preference, limitation, or specification based on religion, national origin, sex, or age forty (40) and over, or because the person is a qualified individual with a disability, when religion, national origin, sex, or age forty (40) and over, or because the person is a qualified individual with a disability, is a bona fide occupational qualification for employment.

## EXECUTIVE BRANCH CODE OF ETHICS

In the 1992 regular legislative session, the General Assembly passed and Governor Brereton Jones signed Senate Bill 63 (codified as KRS 11A), the Executive Branch Code of Ethics, which states, in part:

KRS 11A.040 (7) provides:

No present or former public servant shall, within six (6) months following termination of his office or employment, accept employment, compensation, or other economic benefit from any person or business that contracts or does business with, or is regulated by, the state in matters in which he was directly involved during the last thirty-six (36) months of his tenure. This provision shall not prohibit an individual from returning to the same business, firm, occupation, or profession in which he was involved prior to taking office or beginning his term of employment, or for which he received, prior to his state employment, a professional degree or license, provided that, for a period of six (6) months, he personally refrains from working on any matter in which he was directly involved during the last thirty-six (36) months of his tenure in state government. This subsection shall not prohibit the performance of ministerial functions, including but not limited to filing tax returns, filing applications for permits or licenses, or filing incorporation papers, nor shall it prohibit the former officer or public servant from receiving public funds disbursed through entitlement programs.

KRS 11A.040 (9) states:

A former public servant shall not represent a person or business before a state agency in a matter in which the former public servant was directly involved during the last thirty-six (36) months of his tenure, for a period of one (1) year after the latter of:

- a) The date of leaving office or termination of employment; or
- b) The date the term of office expires to which the public servant was elected.

This law is intended to promote public confidence in the integrity of state government and to declare as public policy the idea that state employees should view their work as a public trust and not as a way to obtain private benefits.

If you have worked for the executive branch of state government within the past six months, you may be subject to the law's prohibitions. The law's applicability may be different if you hold elected office or are contemplating representation of another before a state agency.

Also, if you are affiliated with a firm which does business with the state and which employs former state executive-branch employees, you should be aware that the law may apply to them.

In case of doubt, the law permits you to request an advisory opinion from the Executive Branch Ethics Commission, 1025 Capital Center Drive, Suite 104, Frankfort, Kentucky 40601; telephone (502) 564-7954.

Revised: May 23, 2022

### **Kentucky Equal Employment Opportunity Act of 1978**

The requirements of the Kentucky Equal Employment Opportunity Act of 1978 (KRS 45.560-45.640) shall apply to this Contract. The apparent low Bidder will be required to submit EEO forms to the Division of Construction Procurement, which will then forward to the Finance and Administration Cabinet for review and approval. No award will become effective until all forms are submitted and EEO/CC has certified compliance. The required EEO forms are as follows:

- EEO-1: Employer Information Report
- Affidavit of Intent to Comply
- Employee Data Sheet
- Subcontractor Report

These forms are available on the Finance and Administration's web page under ***Vendor Information, Standard Attachments and General Terms*** at the following address:  
**<https://www.eProcurement.ky.gov>**.

Bidders currently certified as being in compliance by the Finance and Administration Cabinet may submit a copy of their approval letter in lieu of the referenced EEO forms.

For questions or assistance please contact the Finance and Administration Cabinet by email at **[finance.contractcompliance@ky.gov](mailto:finance.contractcompliance@ky.gov)** or by phone at 502-564-2874.

# EMPLOYEE RIGHTS UNDER THE FAIR LABOR STANDARDS ACT

THE UNITED STATES DEPARTMENT OF LABOR WAGE AND HOUR DIVISION

## FEDERAL MINIMUM WAGE

# \$7.25

 PER HOUR

BEGINNING JULY 24, 2009

### OVERTIME PAY

At least 1½ times your regular rate of pay for all hours worked over 40 in a workweek.

### CHILD LABOR

An employee must be at least **16** years old to work in most non-farm jobs and at least **18** to work in non-farm jobs declared hazardous by the Secretary of Labor.

Youths **14** and **15** years old may work outside school hours in various non-manufacturing, non-mining, non-hazardous jobs under the following conditions:

**No more than**

- **3** hours on a school day or **18** hours in a school week;
- **8** hours on a non-school day or **40** hours in a non-school week.

Also, work may not begin before **7 a.m.** or end after **7 p.m.**, except from June 1 through Labor Day, when evening hours are extended to **9 p.m.** Different rules apply in agricultural employment.

### TIP CREDIT

Employers of "tipped employees" must pay a cash wage of at least \$2.13 per hour if they claim a tip credit against their minimum wage obligation. If an employee's tips combined with the employer's cash wage of at least \$2.13 per hour do not equal the minimum hourly wage, the employer must make up the difference. Certain other conditions must also be met.

### ENFORCEMENT

The Department of Labor may recover back wages either administratively or through court action, for the employees that have been underpaid in violation of the law. Violations may result in civil or criminal action.

Employers may be assessed civil money penalties of up to \$1,100 for each willful or repeated violation of the minimum wage or overtime pay provisions of the law and up to \$11,000 for each employee who is the subject of a violation of the Act's child labor provisions. In addition, a civil money penalty of up to \$50,000 may be assessed for each child labor violation that causes the death or serious injury of any minor employee, and such assessments may be doubled, up to \$100,000, when the violations are determined to be willful or repeated. The law also prohibits discriminating against or discharging workers who file a complaint or participate in any proceeding under the Act.

### ADDITIONAL INFORMATION

- Certain occupations and establishments are exempt from the minimum wage and/or overtime pay provisions.
- Special provisions apply to workers in American Samoa and the Commonwealth of the Northern Mariana Islands.
- Some state laws provide greater employee protections; employers must comply with both.
- The law requires employers to display this poster where employees can readily see it.
- Employees under 20 years of age may be paid \$4.25 per hour during their first 90 consecutive calendar days of employment with an employer.
- Certain full-time students, student learners, apprentices, and workers with disabilities may be paid less than the minimum wage under special certificates issued by the Department of Labor.

For additional information:



# 1-866-4-USWAGE

(1-866-487-9243)

TTY: 1-877-889-5627



# WWW.WAGEHOUR.DOL.GOV

**PART IV**  
**INSURANCE**

Refer to  
*Kentucky Standard Specifications for Road and Bridge Construction,*  
current edition

**PART V**  
**BID ITEMS**

### PROPOSAL BID ITEMS

222969

Page 1 of 4

Report Date 6/28/22

#### Section: 0001 - BRIDGES

LINE	BID CODE	ALT	DESCRIPTION	QUANTITY	UNIT	UNIT PRIC	FP	AMOUNT
0010	02562		TEMPORARY SIGNS - 054B00208N	145.00	SQFT		\$	
0020	02650		MAINTAIN & CONTROL TRAFFIC - 054B00208N	1.00	LS		\$	
0030	02653		LANE CLOSURE - 054B00208N	2.00	EACH		\$	
0040	03294		EXPAN JOINT REPLACE 1 1/2 IN - 054B00208N	92.20	LF		\$	
0050	03304		BRIDGE OVERLAY APPROACH PAVEMENT - 054B00208N	1,011.00	SQYD		\$	
0060	04933		TEMP SIGNAL 2 PHASE - 054B00208N	1.00	EACH		\$	
0070	06514		PAVE STRIPING-PERM PAINT-4 IN - 054B00208N	780.00	LF		\$	
0080	06549		PAVE STRIPING-TEMP REM TAPE-B - 054B00208N	1,000.00	LF		\$	
0090	06550		PAVE STRIPING-TEMP REM TAPE-W - 054B00208N	2,000.00	LF		\$	
0100	06551		PAVE STRIPING-TEMP REM TAPE-Y - 054B00208N	2,000.00	LF		\$	
0110	08150		STEEL REINFORCEMENT - 054B00208N	270.00	LB		\$	
0120	08504		EPOXY SAND SLURRY - 054B00208N	30.00	SQYD		\$	
0130	08526		CONC CLASS M FULL DEPTH PATCH - 054B00208N	1.00	CUYD		\$	
0140	08534		CONCRETE OVERLAY-LATEX - 054B00208N	23.40	CUYD		\$	
0150	08549		BLAST CLEANING - 054B00208N	591.00	SQYD		\$	
0160	08551		MACHINE PREP OF SLAB - 054B00208N	561.00	SQYD		\$	
0170	24094EC		PARTIAL DEPTH PATCHING - 054B00208N	11.70	CUYD		\$	

#### Section: 0002 - BRIDGES

LINE	BID CODE	ALT	DESCRIPTION	QUANTITY	UNIT	UNIT PRIC	FP	AMOUNT
0180	02562		TEMPORARY SIGNS - 075B00074N	145.00	SQFT		\$	
0190	02650		MAINTAIN & CONTROL TRAFFIC - 075B00074N	1.00	LS		\$	
0200	02653		LANE CLOSURE - 075B00074N	2.00	EACH		\$	
0210	03299		ARMORED EDGE FOR CONCRETE - 075B00074N	55.00	LF		\$	
0220	03304		BRIDGE OVERLAY APPROACH PAVEMENT - 075B00074N	612.00	SQYD		\$	
0230	04933		TEMP SIGNAL 2 PHASE - 075B00074N	1.00	EACH		\$	
0240	06514		PAVE STRIPING-PERM PAINT-4 IN - 075B00074N	678.00	LF		\$	

**PROPOSAL BID ITEMS**

222969

Page 2 of 4

Report Date 6/28/22

LINE	BID CODE	ALT	DESCRIPTION	QUANTITY	UNIT	UNIT PRIC	FP	AMOUNT
0250	06549		PAVE STRIPING-TEMP REM TAPE-B - 075B00074N	1,000.00	LF		\$	
0260	06550		PAVE STRIPING-TEMP REM TAPE-W - 075B00074N	2,000.00	LF		\$	
0270	06551		PAVE STRIPING-TEMP REM TAPE-Y - 075B00074N	2,000.00	LF		\$	
0280	08150		STEEL REINFORCEMENT - 075B00074N	270.00	LB		\$	
0290	08504		EPOXY SAND SLURRY - 075B00074N	38.00	SQYD		\$	
0300	08526		CONC CLASS M FULL DEPTH PATCH - 075B00074N	1.00	CUYD		\$	
0310	08534		CONCRETE OVERLAY-LATEX - 075B00074N	16.80	CUYD		\$	
0320	08549		BLAST CLEANING - 075B00074N	442.00	SQYD		\$	
0330	08551		MACHINE PREP OF SLAB - 075B00074N	404.00	SQYD		\$	
0340	24094EC		PARTIAL DEPTH PATCHING - 075B00074N	8.40	CUYD		\$	

**Section: 0003 - BRIDGES**

LINE	BID CODE	ALT	DESCRIPTION	QUANTITY	UNIT	UNIT PRIC	FP	AMOUNT
0350	02562		TEMPORARY SIGNS - 075B00070N	145.00	SQFT		\$	
0360	02650		MAINTAIN & CONTROL TRAFFIC - 075B00070N	1.00	LS		\$	
0370	02653		LANE CLOSURE - 075B00070N	2.00	EACH		\$	
0380	03294		EXPAN JOINT REPLACE 1 1/2 IN - 075B00070N	67.00	LF		\$	
0390	03304		BRIDGE OVERLAY APPROACH PAVEMENT - 075B00070N	745.00	SQYD		\$	
0400	04933		TEMP SIGNAL 2 PHASE - 075B00070N	1.00	EACH		\$	
0410	06514		PAVE STRIPING-PERM PAINT-4 IN - 075B00070N	514.00	LF		\$	
0420	06549		PAVE STRIPING-TEMP REM TAPE-B - 075B00070N	1,000.00	LF		\$	
0430	06550		PAVE STRIPING-TEMP REM TAPE-W - 075B00070N	2,000.00	LF		\$	
0440	06551		PAVE STRIPING-TEMP REM TAPE-Y - 075B00070N	2,000.00	LF		\$	
0450	08150		STEEL REINFORCEMENT - 075B00070N	270.00	LB		\$	
0460	08504		EPOXY SAND SLURRY - 075B00070N	42.00	SQYD		\$	
0470	08534		CONCRETE OVERLAY-LATEX - 075B00070N	23.70	CUYD		\$	
0480	08549		BLAST CLEANING - 075B00070N	610.00	SQYD		\$	
0490	08551		MACHINE PREP OF SLAB - 075B00070N	568.00	SQYD		\$	



### PROPOSAL BID ITEMS

222969

Page 3 of 4

Report Date 6/28/22

LINE	BID CODE	ALT	DESCRIPTION	QUANTITY	UNIT	UNIT PRIC	FP	AMOUNT
0500	24094EC		PARTIAL DEPTH PATCHING - 075B00070N	11.80	CUYD		\$	

#### Section: 0004 - BRIDGES

LINE	BID CODE	ALT	DESCRIPTION	QUANTITY	UNIT	UNIT PRIC	FP	AMOUNT
0510	02562		TEMPORARY SIGNS - 089B00110N	145.00	SQFT		\$	
0520	02650		MAINTAIN & CONTROL TRAFFIC - 089B00110N	1.00	LS		\$	
0530	02653		LANE CLOSURE - 089B00110N	2.00	EACH		\$	
0540	03294		EXPAN JOINT REPLACE 1 1/2 IN - 089B00110N	91.20	LF		\$	
0550	03299		ARMORED EDGE FOR CONCRETE - 089B00110N	91.20	LF		\$	
0560	03304		BRIDGE OVERLAY APPROACH PAVEMENT - 089B00110N	1,011.00	SQYD		\$	
0570	04933		TEMP SIGNAL 2 PHASE - 089B00110N	1.00	EACH		\$	
0580	06514		PAVE STRIPING-PERM PAINT-4 IN - 089B00110N	730.00	LF		\$	
0590	06549		PAVE STRIPING-TEMP REM TAPE-B - 089B00110N	1,000.00	LF		\$	
0600	06550		PAVE STRIPING-TEMP REM TAPE-W - 089B00110N	2,000.00	LF		\$	
0610	06551		PAVE STRIPING-TEMP REM TAPE-Y - 089B00110N	2,000.00	LF		\$	
0620	08150		STEEL REINFORCEMENT - 089B00110N	270.00	LB		\$	
0630	08504		EPOXY SAND SLURRY - 089B00110N	97.00	SQYD		\$	
0640	08526		CONC CLASS M FULL DEPTH PATCH - 089B00110N	1.00	CUYD		\$	
0650	08534		CONCRETE OVERLAY-LATEX - 089B00110N	34.20	CUYD		\$	
0660	08549		BLAST CLEANING - 089B00110N	917.00	SQYD		\$	
0670	08551		MACHINE PREP OF SLAB - 089B00110N	820.00	SQYD		\$	
0680	24094EC		PARTIAL DEPTH PATCHING - 089B00110N	17.10	CUYD		\$	

#### Section: 0005 - BRIDGES

LINE	BID CODE	ALT	DESCRIPTION	QUANTITY	UNIT	UNIT PRIC	FP	AMOUNT
0690	02562		TEMPORARY SIGNS - 117B00118N	145.00	SQFT		\$	
0700	02650		MAINTAIN & CONTROL TRAFFIC - 117B00118N	1.00	LS		\$	
0710	02653		LANE CLOSURE - 117B00118N	2.00	EACH		\$	

**PROPOSAL BID ITEMS**

222969

Page 4 of 4

Report Date 6/28/22

LINE	BID CODE	ALT	DESCRIPTION	QUANTITY	UNIT	UNIT PRIC	FP	AMOUNT
0720	03299		ARMORED EDGE FOR CONCRETE - 117B00118N	80.80	LF		\$	
0730	04933		TEMP SIGNAL 2 PHASE - 117B00118N	1.00	EACH		\$	
0740	06514		PAVE STRIPING-PERM PAINT-4 IN - 117B00118N	64.00	LF		\$	
0750	06549		PAVE STRIPING-TEMP REM TAPE-B - 117B00118N	1,000.00	LF		\$	
0760	06550		PAVE STRIPING-TEMP REM TAPE-W - 117B00118N	2,000.00	LF		\$	
0770	06551		PAVE STRIPING-TEMP REM TAPE-Y - 117B00118N	2,000.00	LF		\$	
0780	08150		STEEL REINFORCEMENT - 117B00118N	270.00	LB		\$	
0790	08504		EPOXY SAND SLURRY - 117B00118N	39.00	SQYD		\$	
0800	08510		REM EPOXY BIT FOREIGN OVERLAY - 117B00118N	107.00	SQYD		\$	
0810	08534		CONCRETE OVERLAY-LATEX - 117B00118N	4.40	CUYD		\$	
0820	08549		BLAST CLEANING - 117B00118N	146.00	SQYD		\$	
0830	24094EC		PARTIAL DEPTH PATCHING - 075B00070N	2.20	CUYD		\$	

**Section: 0006 - DEMOB**

LINE	BID CODE	ALT	DESCRIPTION	QUANTITY	UNIT	UNIT PRIC	FP	AMOUNT
0840	02569		DEMOBILIZATION	1.00	LS		\$	