



CALL NO. 402

CONTRACT ID. 222441

KENTON COUNTY

FED/STATE PROJECT NUMBER 059GR22P057 - FD05 & FD04

DESCRIPTION TAYLOR MILL ROAD (KY 3716)

WORK TYPE ASPHALT RESURFACING

PRIMARY COMPLETION DATE 6/30/2023

LETTING DATE: July 21,2022

Sealed Bids will be received electronically through the Bid Express bidding service until 10:00 AM EASTERN DAYLIGHT TIME July 21,2022. Bids will be publicly announced at 10:00 AM EASTERN DAYLIGHT TIME.

NO PLANS ASSOCIATED WITH THIS PROJECT.

REQUIRED BID PROPOSAL GUARANTY: Not less than 5% of the total bid.

TABLE OF CONTENTS

PART I	SCOPE OF WORK
	<ul style="list-style-type: none">• PROJECT(S), COMPLETION DATE(S), & LIQUIDATED DAMAGES• CONTRACT NOTES• STATE CONTRACT NOTES• SURFACING AREAS• ASPHALT MIXTURE• INCIDENTAL SURFACING• FUEL AND ASPHALT PAY ADJUSTMENT• COMPACTION OPTION A• SPECIAL NOTE(S) APPLICABLE TO PROJECT• WASTE AND BORROW SITES• EXPERIMENTAL KYCT AND HAMBURG TESTING• COORDINATION OF WORK WITH OTHER CONTRACTS• GUARDRAIL• ASPHALT MILLING AND TEXTURING• BASE FAILURE REPAIR• TYPICAL SECTION DIMENSIONS• TRAFFIC CONTROL PLAN 4 LANE• DURABLE PAVEMENT EDGE DETAILS• TRAFFIC SIGNAL LOOP DETECTORS• EROSION CONTROL PLAN FOR MAINTENANCE PROJECTS• SKETCH MAP(S)• MATERIAL SUMMARY• SUMMARY SHEET(S)• TYPICAL SECTION(S)• DETAIL SHEET(S)• GUARDRAIL DELIVERY VERIFICATION SHEET
PART II	SPECIFICATIONS AND STANDARD DRAWINGS
	<ul style="list-style-type: none">• SPECIFICATIONS REFERENCE• SUPPLEMENTAL SPECIFICATION• [SN-11] PORTABLE CHANGEABLE SIGNS• 2020 STANDARD DRAWINGS THAT APPLY
PART III	EMPLOYMENT, WAGE AND RECORD REQUIREMENTS
	<ul style="list-style-type: none">• LABOR AND WAGE REQUIREMENTS• EXECUTIVE BRANCH CODE OF ETHICS• KENTUCKY EQUAL EMPLOYMENT OPPORTUNITY ACT OF 1978 LOCALITY / STATE• PROJECT WAGE RATES / STATE FUNDED
PART IV	INSURANCE
PART V	BID ITEMS

PART I
SCOPE OF WORK

ADMINISTRATIVE DISTRICT - 06

CONTRACT ID - 222441

059GR22P057 - FD05 & FD04

COUNTY - KENTON

PCN - MP05937162201

FD05 059 3716 000-005

TAYLOR MILL ROAD (KY 3716) (MP 0.000) BEGINNING AT KY 1501 EXTENDING NORTH TO KY 16. (MP 4.277), A DISTANCE OF 04.27 MILES.ASPHALT RESURFACING

GEOGRAPHIC COORDINATES LATITUDE 39:59:53.00 LONGITUDE 84:29:45.00

ADT 7,575

PCN - MP05937162202

FD04 059 3716 000-002

WAYMANS BRANCH (KY 3716) (MP 0.000) BEGIN AT KY 1501 EXTENDING EAST TO HIGHBRIDGE DRIVE/OLD WAYMAN BRANCH ROAD (MP 1.322), A DISTANCE OF 01.32 MILES.CULVERT REPLACEMENT SYP NO. 06-80256.

GEOGRAPHIC COORDINATES LATITUDE 38:59:31.00 LONGITUDE 84:31:05.00

ADT 1,393

COMPLETION DATE(S):

COMPLETED BY 06/30/2023

APPLIES TO ENTIRE CONTRACT

CONTRACT NOTES

PROPOSAL ADDENDA

All addenda to this proposal must be applied when calculating bid and certified in the bid packet submitted to the Kentucky Department of Highways. Failure to use the correct and most recent addenda may result in the bid being rejected.

BID SUBMITTAL

Bidder must use the Department's electronic bidding software. The Bidder must download the bid file located on the Bid Express website (www.bidx.com) to prepare a bid packet for submission to the Department. The bidder must submit electronically using Bid Express.

JOINT VENTURE BIDDING

Joint venture bidding is permissible. All companies in the joint venture must be prequalified in one of the work types in the Qualifications for Bidders for the project. The bidders must get a vendor ID for the joint venture from the Division of Construction Procurement and register the joint venture as a bidder on the project. Also, the joint venture must obtain a digital ID from Bid Express to submit a bid. A joint bid bond of 5% may be submitted for both companies or each company may submit a separate bond of 5%.

UNDERGROUND FACILITY DAMAGE PROTECTION

The contractor shall make every effort to protect underground facilities from damage as prescribed in the Underground Facility Damage Protection Act of 1994, Kentucky Revised Statute KRS 367.4901 to 367.4917. It is the contractor's responsibility to determine and take steps necessary to be in compliance with federal and state damage prevention directives. When prescribed in said directives, the contractor shall submit Excavation Locate Requests to the Kentucky Contact Center (KY811) via web ticket entry. The submission of this request does not relieve the contractor from the responsibility of contacting non-member facility owners, whom shall be contacted through their individual Protection Notification Center. Non-compliance with these directives can result in the enforcement of penalties.

REGISTRATION WITH THE SECRETARY OF STATE BY A FOREIGN ENTITY

Pursuant to KRS 176.085(1)(b), an agency, department, office, or political subdivision of the Commonwealth of Kentucky shall not award a state contract to a person that is a foreign entity required by [KRS 14A.9-010](#) to obtain a certificate of authority to transact business in the Commonwealth ("certificate") from the Secretary of State under [KRS 14A.9-030](#) unless the person produces the certificate within fourteen (14) days of the bid or proposal opening. If the foreign entity is not required to obtain a certificate as provided in [KRS 14A.9-010](#), the foreign entity should identify the applicable exception. Foreign entity is defined within [KRS 14A.1-070](#).

For all foreign entities required to obtain a certificate of authority to transact business in the Commonwealth, if a copy of the certificate is not received by the contracting agency within the time frame identified above, the foreign entity's solicitation response shall be deemed non-responsive or the awarded contract shall be cancelled.

Businesses can register with the Secretary of State at <https://secure.kentucky.gov/sos/ftbr/welcome.aspx>.

SPECIAL NOTE FOR PROJECT QUESTIONS DURING ADVERTISEMENT

Questions about projects during the advertisement should be submitted in writing to the Division of Construction Procurement. This may be done by fax (502) 564-7299 or email to kytc.projectquestions@ky.gov. The Department will attempt to answer all submitted questions. The Department reserves the right not to answer if the question is not pertinent or does not aid in clarifying the project intent.

The deadline for posting answers will be 3:00 pm Eastern Daylight Time, the day preceding the Letting. Questions may be submitted until this deadline with the understanding that the later a question is submitted, the less likely an answer will be able to be provided.

The questions and answers will be posted for each Letting under the heading "Questions & Answers" on the Construction Procurement website (www.transportation.ky.gov/contract). The answers provided shall be considered part of this Special Note and, in case of a discrepancy, will govern over all other bidding documents.

HARDWOOD REMOVAL RESTRICTIONS

The US Department of Agriculture has imposed a quarantine in Kentucky and several surrounding states, to prevent the spread of an invasive insect, the emerald ash borer. Hardwood cut in conjunction with the project may not be removed from the state. Chipping or burning on site is the preferred method of disposal.

INSTRUCTIONS FOR EXCESS MATERIAL SITES AND BORROW SITES

Identification of excess material sites and borrow sites shall be the responsibility of the Contractor. The Contractor shall be responsible for compliance with all applicable state and federal laws and may wish to consult with the US Fish and Wildlife Service to seek protection under Section 10 of the Endangered Species Act for these activities.

ACCESS TO RECORDS

The contractor, as defined in KRS 45A.030 (9) agrees that the contracting agency, the Finance and Administration Cabinet, the Auditor of Public Accounts, and the Legislative Research Commission, or their duly authorized representatives, shall have access to any books, documents, papers, records, or other evidence, which are directly pertinent to this contract for the purpose of financial audit or program review. Records and other prequalification information confidentially

disclosed as part of the bid process shall not be deemed as directly pertinent to the contract and shall be exempt from disclosure as provided in KRS 61.878(1)(c). The contractor also recognizes that any books, documents, papers, records, or other evidence, received during a financial audit or program review shall be subject to the Kentucky Open Records Act, KRS 61.870 to 61.884.

In the event of a dispute between the contractor and the contracting agency, Attorney General, or the Auditor of Public Accounts over documents that are eligible for production and review, the Finance and Administration Cabinet shall review the dispute and issue a determination, in accordance with Secretary's Order 11-004.

April 30, 2018

SPECIAL NOTE FOR RECIPROCAL PREFERENCE

RECIPROCAL PREFERENCE TO BE GIVEN BY PUBLIC AGENCIES TO RESIDENT BIDDERS

By reference, KRS 45A.490 to 45A.494 are incorporated herein and in compliance regarding the bidders residency. Bidders who want to claim resident bidder status should complete the Affidavit for Claiming Resident Bidder Status along with their bid in the electronic bidding software. Submittal of the Affidavit should be done along the bid in Bid Express.

April 30, 2018

SURFACING AREAS FD05 059 3716 000-005

The Department estimates the mainline surfacing width to be varied 22-36 feet.

The Department estimates the total mainline area to be surfaced to be 65,802 square yards.

The Department estimates the shoulder width to be varied 0-1 feet on each side.

The Department estimates the total shoulder area to be surfaced to be 4,338 square yards.

SURFACING AREAS FD04 059 3716 000-002

The Department estimates the mainline surfacing width to be 24 feet.

The Department estimates the total mainline area to be surfaced to be 19,544 square yards.

The Department estimates the shoulder width to be N/A feet on each side.

The Department estimates the total shoulder area to be surfaced to be N/A square yards.

ASPHALT MIXTURE

Unless otherwise noted, the Department estimates the rate of application for all asphalt mixtures to be 110 lbs/sy per inch of depth.

INCIDENTAL SURFACING

The Department has included in the quantities of asphalt mixtures established in the proposal estimated quantities required for resurfacing or surfacing mailbox turnouts, farm field entrances, residential and commercial entrances, curve widening, ramp gores and tapers, and road and street approaches, as applicable. Pave these areas to the limits as shown on Standard Drawing RPM-110-06 or as directed by the Engineer. In the event signal detectors are present in the intersecting streets or roads, pave the crossroads to the right of way limit or back of the signal detector, whichever is the farthest back of the mainline. Surface or resurface these areas as directed by the Engineer. The Department will not measure placing and compacting for separate payment but shall be incidental to the Contract unit price for the asphalt mixtures.

FUEL AND ASPHALT PAY ADJUSTMENT

The Department has included the Contract items Asphalt Adjustment and Fuel Adjustment for possible future payments at an established Contract unit price of \$1.00. The Department will calculate actual adjustment quantities after work is completed. If existing Contract amount is insufficient to pay all items on the contract with the adjustments, the Department will establish additional monies with a change order.

OPTION A

Be advised that the Department will accept compaction of asphalt mixtures furnished for driving lanes and ramps, at 1 inch (25mm) or greater, on this project according to OPTION A in accordance with Section 402 and Section 403 of the current Standard Specifications. The Department will require joint cores as described in Section 402.03.02 for surface mixtures only. The Department will accept compaction of all other asphalt mixtures according to OPTION B.

SPECIAL NOTES FOR NEW STRIPING PATTERN FD05 059 3716 000-005

Currently, KY 3716 is striped to have 12-foot-wide travel lanes. The new striping pattern shall reduce the travel lanes to 11 feet wide. The striping shall follow the plan as described below:

Lane Reconfiguration

Taylor Mill Road is currently striped to include 12' lanes and the pavement width at this location in the curve is 28' (2' paved shoulders). The speed limit on Taylor Mill Road (KY 3716) was recently reduced to 35 MPH. Taylor Mill Road state maintained roadway that is classified as a rural collector and according to [KYTC's Traffic Count Map](#), and the highest ADT area along Taylor Mill Road is 7,575 VPD (2019). Exhibit 700-02 of [KYTC's Geometric Design Guidelines](#) require that a rural collector with an ADT over 2,000 with a design speed under 50 MPH have 11' lanes.

The City is requesting to restripe the lanes in the curve area (superelevated section) to include 11' lanes by holding the southbound lane line for the placement of the two 11' lanes. The roadway centerline location will shift but since this adjustment will be within in a superelevated curve, the centerline can transition back to the normal crown location and no pavement adjustments are necessary. This alternative would provide the sidewalk on the northbound shoulder an additional 2' of separation from the travel way to minimum of 5' (variable 4' asphalt + 1 earthen shoulder) in the "pinch point" location as existing. It should be noted that per the [Crash Modification Factors Clearinghouse](#), the safety countermeasure to convert 12' lanes to 11' lanes provides a CMF of 0.85 or 15% Crash Reduction Factor.

SPECIAL NOTES FOR DITCHING
KENTON COUNTY
FD04 059 3716 000-002

A drainage ditch shall be installed, improved or lined with Class 2 channel lining from KY 1501 to Old Wayman. The ditch will be installed for the entire corridor, but it may be on the East or West side of the roadway. There are no sections with a drainage ditch on both sides. The total estimated length for construction of a drainage ditch is 6,320 Linear Feet. The Contractor shall coordinate the ditch construction with the Project Engineer and all locations shall be verified and marked with the Engineer prior to any work including the areas requiring channel lining.

All work shall be done in accordance with the current Standard Specifications for Road and Bridge Construction and applicable Standard Drawings.

Each Contractor submitting a bid for this work shall make a thorough inspection of the site prior to submitting his bid and shall thoroughly familiarize himself with existing conditions so that the work can be expeditiously performed after a contract is awarded. Submission of a bid will be considered evidence of this inspection having been made. Any claims resulting from site conditions will not be honored by the Department. All utilities shall be mark before construction begins. There may be utility service lines and/or water lines in the pipe removal area.

Information shown on the drawings and in this proposal and the types and quantities of work listed are approximate only, and are not be taken as an accurate or complete evaluation of the material and conditions to be encountered during construction. The bidder must draw his own conclusion as to the conditions encountered. The department does not give any guarantee as to the accuracy of the data and no claim will be considered for additional compensation if the conditions encountered are not in accordance with the information shown.

The exact limits of Right-of-Way have not been established by the Department. The Contractor shall limit his activities to obvious Right-of-Way and work areas secured by the Department through Consent and Release of the adjacent property owners and shall be responsible for all encroachments onto private lands.

The Contractor will be responsible for all damage to public and/or private property resulting from his work.

**SPECIAL NOTES FOR PIPE REPLACEMENT
AND GABION BASKET INSTALLATION
KENTON COUNTY
FD04 059 3716 000-002**

The following shall be incidental to the bid item “18 in. Circular Culvert Pipe”, “24 in. Circular Culvert Pipe” & “36 in. Circular Culvert Pipe” unless a specific bid item is listed.

- (1) Removal of existing drainage structure (s) at proposed location.
- (2) Pipe bedding; including fabric and stone base
- (3) Installation of “Culvert Pipes”
- (4) Furnish all materials, labor and equipment.
- (5) Keeping the following people aware of the work schedule so they may adjust their routes:
 - (a) County Judge-Executive
 - (b) U.S. Postal Service
 - (c) Fire Department
 - (d) Ambulance Services
 - (e) Public Transportation (Bus)
 - (f) State Police
 - (g) Sheriff and /or County Police
 - (h) School Systems

The following paragraphs indicate the construction requirements pertaining to this project.

The Contractor shall coordinate the removal, replacement and reconstruction of the existing drainage structures with the Engineer. All locations shall be verified and marked with the Engineer prior to any work.

All work shall be done in accordance with the current Standard Specifications for Road and Bridge Construction except as provided herein and elsewhere in the proposal, these “Special Notes” Pipe Log (if applicable) and applicable Standard Drawings.

The Department will sample and test all materials according to Department's Sampling Manual and the Contractor shall have the materials available for sampling a sufficient time in advance of the use of the materials to allow for the necessary time for testing, unless otherwise specified in these notes.

Location 1 MP 0.00

Extend pipe wingwalls and construct top with Class A concrete to eliminate drop-off at the intersection with Hands Pike. Backfill with soil and seed.

Location 2 MP 0.23

Remove existing 30' long, 24" Corrugated Metal Pipe (CMP) and install a 40' long, 24" Corrugated High Density Polyethylene (HDPE) Pipe.

Location 3 MP 0.36

Remove existing 24' long, 15" Corrugated Metal Pipe (CMP) and install a 32' long, 18" Corrugated High Density Polyethylene (HDPE) Pipe.

Location 4 MP 0.41

Remove existing 32' long, 24" Corrugated Metal Pipe (CMP) and install a 32' long, 24" Corrugated High Density Polyethylene (HDPE) Pipe.

Location 5 MP 0.52

Remove existing 40' long, 24" Corrugated Metal Pipe (CMP) and install a 40' long, 24" Corrugated High Density Polyethylene (HDPE) Pipe.

Location 6 MP 0.54

The existing 40' long, 60" concrete culvert is in good condition and shall not be disturbed. Install two rows of Gabion Baskets (24' long by 6' high) on the south side of the culvert outlet. Backfill on a 2:1 slope with approximately 100 tons of Class 2 Channel Lining up to the roadway shoulder.

Location 7 MP 0.56

Remove existing 40' long, 24" Corrugated Metal Pipe (CMP) and install a 40' long, 36" Corrugated High Density Polyethylene (HDPE) Pipe.

Location 8 MP 0.60

Remove the existing 48' long, 6' high Gabion Basket retaining wall and Replace with a 48' long, 6' high Gabion Basket retaining wall. Ensure when the new wall is installed that there is room for a drainage ditch.

Location 9 MP 0.82

Safe Load the existing 40' long, 15" Corrugated Metal Pipe (CMP) from the roadway ditch and install a 70' long, 18" Corrugated High Density Polyethylene (HDPE) Pipe across the entrance at box number 2900.

Location 10 MP 0.92

Remove existing 40' long, 18" Corrugated Metal Pipe (CMP) and install a 40' long, 24" Corrugated High Density Polyethylene (HDPE) Pipe.

Location 11 MP 1.03

Remove existing 136' long, 24" Corrugated Metal Pipe (CMP) and install a 136' long, 24" Corrugated High Density Polyethylene (HDPE) Pipe.

Roadway shall be saw-cut prior to any removal or installation of new culvert pipe. The pipe shall be placed on No. 8 Aggregate bedding wrapped with geotextile fabric type Class 2. The trench below the roadbed shall be backfilled with flowable fill (pH range medium) to existing subgrade. Raise to existing surface with 3 inch lifts of C1 2 Asphalt Base. All work and materials without a specific bid item shall be incidental to culvert pipe.

After all work is completed, debris from construction shall be completely removed from the job site. All disturbed areas shall be satisfactorily graded and then roughened to prepare the seed bed for the seeding and protection. Re-seed and straw all disturbed areas.

The maintaining and controlling of traffic shall be the responsibility of the Contractor. The Contractor shall furnish, install and maintain advance construction signs in accordance with the Manual on Uniform Traffic Control Devices, the Department's Standard Specifications for Road and Bridge Construction and applicable Standard Drawings.

Where it is necessary to maintain one lane of traffic or leave open trenches at night, the Contractor shall strictly adhere to all nighttime traffic control regulations. The project may be closed to through traffic during working hours. Maintain local traffic and access for the residents. The pipe removal and replacement portion of the project shall be completed in no longer than 8 days.

The installation of pipe shall be in conformance with the requirements of Section 701 of the current Standard Specifications for Road and Bridge Construction as applicable to this project, these "Special Notes", and applicable Standard Drawings.

The Contractor shall remove and dispose of all debris and waste in a manner acceptable to the Engineer and in accordance with the disposal requirements of Section 202.03 of the current Standard Specifications.

The Contractor shall furnish all equipment, materials, labor, including the "Culvert Pipe".

All applicable materials and construction requirements for pipe culverts shall be in conformance with Sections 701 and 612 of the current Standard Specifications, these "Special Notes", and applicable Standard Drawings.

All pipe flow line grades will be established by the Engineer and shall meet existing ditch channel elevations. Positive drainage is required upon completion of the project and shall be the responsibility of the Contractor.

Each Contractor submitting a bid for this work shall make a thorough inspection of the site prior to submitting his bid and shall thoroughly familiarize himself with existing conditions so that the work can be expeditiously performed after a contract is awarded. Submission of a bid will be considered evidence of this inspection having been made. Any claims resulting from site conditions will not be honored by the Department. All utilities shall be mark before construction begins. There may be utility service lines and/or water lines in the pipe removal area.

Information shown on the drawings and in this proposal and the types and quantities of work listed are approximate only, and are not be taken as an accurate or complete evaluation of the material and conditions to be encountered during construction. The bidder must draw his own conclusion as to the conditions encountered. The department does not give any guarantee as to the accuracy of the data and no claim will be considered for additional compensation if the conditions encountered are not in accordance with the information shown.

The exact limits of Right-of-Way have not been established by the Department. The Contractor shall limit his activities to obvious Right-of-Way and work areas secured by the Department through Consent and Release of the adjacent property owners and shall be responsible for all encroachments onto private lands.

The Contractor will be responsible for all damage to public and/or private property resulting from his work.

**SPECIAL NOTES FOR TREE TRIMMING
KENTON COUNTY
FD04 059 3716 000-002**

All tree limbs and branches shall be removed above the roadway from edge line to edge line from KY 1501 to Old Wayman. There are areas with overgrowth on both sides of the roadway and areas that are open. The total estimated tree trimming length of the corridor, including each side of the roadway, is 4,800 Linear Feet.

The Contractor shall coordinate the tree trimming with the Project Engineer and all locations shall be verified and marked with the Engineer prior to any work.

All work shall be done in accordance with the current Standard Specifications for Road and Bridge Construction and applicable Standard Drawings.

Each Contractor submitting a bid for this work shall make a thorough inspection of the site prior to submitting his bid and shall thoroughly familiarize himself with existing conditions so that the work can be expeditiously performed after a contract is awarded. Submission of a bid will be considered evidence of this inspection having been made. Any claims resulting from site conditions will not be honored by the Department. All utilities shall be mark before construction begins. There may be utility service lines and/or water lines in the pipe removal area.

Information shown on the drawings and in this proposal and the types and quantities of work listed are approximate only, and are not be taken as an accurate or complete evaluation of the material and conditions to be encountered during construction. The bidder must draw his own conclusion as to the conditions encountered. The department does not give any guarantee as to the accuracy of the data and no claim will be considered for additional compensation if the conditions encountered are not in accordance with the information shown.

The exact limits of Right-of-Way have not been established by the Department. The Contractor shall limit his activities to obvious Right-of-Way and work areas secured by the Department through Consent and Release of the adjacent property owners and shall be responsible for all encroachments onto private lands.

The Contractor will be responsible for all damage to public and/or private property resulting from his work.

SPECIAL PROVISION FOR WASTE AND BORROW SITES

Obtain U.S. Army Corps of Engineer's approval before utilizing a waste or borrow site that involves "Waters of the United States". The Corps of Engineers defines "Waters of the United States" as perennial or intermittent streams, ponds or wetlands. The Corps of Engineers also considers ephemeral streams, typically dry except during rainfall but having a defined drainage channel, to be jurisdictional waters. Direct questions concerning any potential impacts to "Waters of the United States" to the attention of the appropriate District Office for the Corps of Engineers for a determination prior to disturbance. Be responsible for any fees associated with obtaining approval for waste and borrow sites from the U.S. Army Corps of Engineer or other appropriate regulatory agencies.

1-296 Waste & Borrow Sites
01/02/2012

SPECIAL NOTE FOR EXPERIMENTAL KYCT AND HAMBURG TESTING

1.0 General

1.1 Description. The KYCT (Kentucky Method for Cracking Test) and the Hamburg test results will help determine if the mixture is susceptible to cracking and rutting. During the experimental phase, data will be gathered and analyzed by the Department to determine the durability of the bituminous mixes. Additionally, the data will help the Department to create future performance-based specifications which will include the KYCT and Hamburg test methods.

2.0 Equipment

2.1 KYCT Testing Equipment. The Department will require a Marshall Test Press with digital recordation capabilities. Other CT testing equipment may be used for testing with prior approval by the Department.

2.2 Water Baths. One or more water baths will be required that can maintain a temperature of 77° +/- 1.8° F with a digital thermometer showing the water bath temperature. Also, one water bath shall have the ability to suspend gyratory specimen fully submerged in water in accordance with AASHTO T-166, current edition.

2.3 Hamburg Wheel Track Testing. The department encourages the use of the PTI APA/Hamburg Jr. test equipment to perform the loaded wheel testing. The Department will allow different equipment for the Hamburg testing, but the testing device must be approved by the Department prior to testing.

2.4 Gyratory Molds. Gyratory molds will be required to assist in the production of gyratory specimens in accordance with AASHTO T-312, current edition.

2.5 Ovens. Adequate (minimum of two ovens) will be required to accommodate the additional molds and asphalt mixture necessary to perform the acceptance testing as outlined in Section 402 of the Kentucky Standard Specifications for Road and Bridge Construction, current edition.

2.6 Department Equipment. The Department will provide gyratory molds, PINE 850 Test Press with digital recordation, and CT testing equipment to assist during this experimental phase so data can be gathered. Hamburg test specimens will be submitted to the Division of Materials for testing on the PTI APA/Hamburg Jr if the asphalt contractor or district materials office does not have an approved Hamburg testing device.

3.0 Testing Requirements

3.1 Acceptance Testing. Perform all acceptance testing and aggregate gradation as according with Section 402 and Section 403 of the Kentucky Standard Specifications for Road and Bridge Construction, current edition.

3.2 KYCT Testing. Perform crack resistance analysis (KYCT) in accordance with the current Kentucky Method for KYCT Index Testing during the mix design phase and during the plant production of all surface mixtures. For mix design approvals, submit KYCT results on the Department MixPack. For Class 4 mixtures, submit ingredient materials to the Division of Materials for verification.

3.2.1 KYCT Frequency. Obtain an adequate sample of hot mix asphalt to ensure the acceptance testing, gradation, and KYCT gyratory samples can be fabricated and is representative of the bituminous mixture. Acceptance specimens shall be fabricated first, then immediately after, fabricate the KYCT samples with the gyratory compactor in accordance with Section 2.4 of this Special Note. Analysis of the KYCT specimens and gradation will be required one per subplot produced from the same asphalt material and at the same time as the acceptance specimen is sampled and tested.

3.2.2 Number of Specimens and Conditioning. Fabricate specimens in accordance with the Kentucky Method for KYCT Index Testing. Contrary to the method, for field specimens, fabricate a minimum of 3 and up to 6 test specimens. The specimens shall be compacted at the temperature in accordance with KM 64-411. KYCT mix design specimens shall be short-term conditioned uncovered for four hours at compaction temperature in accordance with KM 64-411. Contrary to the Kentucky Method, plant produced bituminous material shall be short-term conditioned immediately after sampling for two hours uncovered in the oven at compaction temperature in accordance with KM 64-411. Additionally, fabricated specimens shall be allowed to cool in air (fan is permissible) for 30 minutes +/- 5 minutes and conditioned in a 77 °F water bath for 30 minutes +/- 5 minutes. To ensure confidence and reliability of the test results provided by KYCT testing and Hamburg testing, reheating of the asphalt mixture is prohibited.

3.2.3 Record Times. For each subplot, record the time required between drying aggregates in the plant to KYCT specimen fabrication. The production time may vary due to the time that the bituminous material is held in the silo. Record the preconditioning time when the time exceeds the one-hour specimen cool down time as required in accordance with The Kentucky Method for KYCT Index Testing. The preconditioning time may exceed an hour if the technician is unable to complete the test on the same day or within the specified times as outlined in The Kentucky Method for KYCT Index Testing. The production time and the preconditioning time shall be recorded on the AMAW.

3.2.4 File Name. As according to section 7.12 of The Kentucky Method for KYCT Index Testing, save the filename with the following format: "CID_Approved Mix Number_Lot Number_Sublot Number_Date"

3.3 Hamburg Testing. Perform the rut resistance analysis (Hamburg) in accordance with AASTHO T-324, not to exceed 20,000 passes for all bituminous mixtures during the mix design phase and production. For mix design approvals, submit Hamburg results on the Department MixPack. For Class 4 mixtures, submit ingredient materials to the Division of Materials for informational verification.

3.3.1 Hamburg Testing Frequency. Perform testing and analysis per lot of material. The plant produced bituminous material sampled for the Hamburg test does not have to be obtained at the same time as the acceptance and KYCT sample. If the Hamburg test sample is not obtained at the same time as the KYCT sample, determine the Maximum Specific Gravity of the KYCT sample in accordance with AASHTO T-209 coinciding with the Hamburg specimens.

3.3.2 Record Times. Record the production time as according to section 3.2.3 in this special note. Also record the time that the specimens were fabricated and the time the Hamburg testing was started. All times shall be recorded on the AMAW.

3.3.3 File Name. Save the Excel spreadsheet with the following file name; “Hamburg_CID_Approved Mix Number_Lot Number_Sublot Number_Date” and upload the file into the AMAW.

4.0 Data

Submit the AMAW and all test data that was obtained for acceptance, gradation, KYCT, and Hamburg testing within five working days once all testing has been completed for a lot to Central Materials Lab and the District Materials Engineer. Also, any data and or comments that the asphalt contractor or district personnel deem informational during this experimental phase, shall also be submitted to the Central Materials Lab and the District Materials Engineer. Any questions or comments regarding any item in this Special Note can be directed to the Central Office, Division of Materials, Asphalt Branch.

5.0 Payment

Any additional labor and testing equipment that is required to fabricate and test the KYCT and Hamburg specimens shall be considered incidental to the asphalt surface line item. The Department will perform the testing for the KYCT and Hamburg specimens if a producer does not possess the proper equipment.

June 15th, 2022

Coordination of Work with others (Project)

The milling and resurfacing of KY 3716 (FD05 059 3716 000-005) shall not begin until the completion of this project. Also, the contractor shall wait 7 days after the asphalt is placed over culvert replacements, to allow settlement before beginning milling and paving operations.

SPECIAL NOTES FOR GUARDRAIL

I. DESCRIPTION

Except as specified herein, perform all work in accordance with the Department's Standard and Supplemental Specifications and Standard and Sepia Drawings, current editions. Article references are to the Standard Specifications.

Furnish all equipment, labor, materials, and incidentals for the following work items:

(1) Site preparation; (2) Remove existing guardrail systems; (3) Construct Guardrail, End Treatments, Bridge End Connectors, and Terminal Sections, as applicable; (4) Delineators for guardrail; (5) Maintain and control traffic; and (6) all other work specified as part of this contract.

II. MATERIALS

Except as specified herein, provide for all materials to be sampled and tested in accordance with the Department's Sampling Manual and make the materials available for sampling a sufficient time in advance of the use of the materials to allow for the necessary time for testing.

A. Maintain and Control Traffic. See Traffic Control Plan.

B. Guardrail. Furnish guardrail system components according to section 814 and the Standard and Sepia Drawings; except use steel posts only, no alternates.

C. Delineators for Guardrail. Delineators for Guardrail. Furnish Delineators for Guardrail according to the Sepia Drawings.

D. Erosion Control. See Special Notes for Erosion Control.

III. CONSTRUCTION METHODS

A. Maintain and Control Traffic. See Traffic Control Plan.

B. Site Preparation. Remove existing guardrail system including the guardrail end treatments, Bridge End connectors and all other elements of the existing guardrail system according to Section 719, except that the Contractor will take possession of all concrete posts and all concrete associated with existing bridge and/or guardrail end treatments. Locate all disposal areas off the Right of Way at sites obtained by the Contractor at no additional cost to the Department. Be responsible for all site preparation, including but not limited to, clearing and grubbing, excavation, embankment, and removal of all obstructions or any other items; regrading, reshaping, adding and compacting of suitable materials on the

Guardrail Page 2 of 3

existing shoulders to provide proper template or foundation for the guardrail; filling voids left as the result of removing existing guardrail and guard posts with dry sand; temporary pollution and erosion control; disposal, of excess and waste materials and debris; and final dressing, cleanup, and seeding and protection. Perform all site preparation as approved or directed by the Engineer.

C. Guardrail. Except as specified herein, construct guardrail system according to Section 719 and the Standard and Sepia Drawings. Locations listed on the summary and/or shown on the drawings are approximate only. The Engineer will determine the exact termini for individual guardrail installations at the time of construction. Unless directed otherwise by the Engineer, provide a minimum two (2) foot shoulder width. Construct radii at entrances and road intersections as directed by the Engineer.

Erect guardrail to the lines and grades shown on current Standard and Sepia Drawings or as directed by the Engineer by any method approved by the Engineer which allows construction of the guardrail to the true grade without apparent sags. Support cantilevered terminal sections with an additional post.

When removing existing guardrail and installing new guardrail, do not leave the blunt end exposed where it would be hazardous to the public. When it is not practical to complete the construction of the guardrail and the permanent end treatments and terminal sections first, provide a temporary end by connecting at least 25 feet of rail to the last post, and by slightly flaring, and burying the end of the rail completely into the existing shoulder. If left overnight, place a drum with bridge panel in advance of the guardrail end and maintain during use.

D. Delineators for Guardrail. Install delineators for guardrail according to the Standard and Sepia Drawings.

E. Property Damage. Be responsible for all damage to public and/or private property resulting from the work. Restore damaged roadway features and private property at no additional cost to the Department.

F. Coordination with Utility Companies. Locate all underground, above ground and overhead utilities prior to beginning construction. Be responsible for contacting and maintaining liaison with all utility companies that have utilities located within the project limits. Do not disturb existing overhead or underground utilities. It is not anticipated that any utility facilities will need to be relocated and/or adjusted; however, in the event that it is discovered that the work does require that utilities be relocated and/or adjusted, the utility companies will work concurrently with the Contractor while relocating their facilities. Be responsible for repairing all utility damage that occurs as a result of guardrail operations at no additional cost to the Department.

G. Right of Way Limits. The Department has not established exact limits of the Right-of-Way. Limit work activities to obvious Right-of-Way, permanent or temporary easements,

Guardrail
Page 3 of 3

and work areas secured by the Department through consent and release of the adjacent property owners. Be responsible for all encroachments onto private lands.

H. Disposal of Waste. Dispose of all removed concrete, debris, and other waste and debris off the Right-of-Way at sites obtained by the Contractor at no additional cost to the Department. See Special; Note for Waste and Borrow.

I. Final Dressing, Clean Up, and Seeding and Protection. Apply Class A Final Dressing to all disturbed areas, both on and off the Right-of-Way. Sow all disturbed earthen areas according to the Special Notes for Erosion Control.

J. Erosion Control. See Special Notes for Erosion Control.

IV. METHOD OF MEASUREMENT

A. Maintain and Control Traffic. See Traffic Control Plan.

B. Site preparation. Other than the bid items listed, the Department will not measure Site Preparation for separate payment but shall be incidental to Guardrail, End Treatments, Bridge End Connectors, and Terminal Sections as applicable.

C. Guardrail. See Section 719.04.

D. Delineators for Guardrail. See the Sepia Drawing.

E. Erosion Control. See Special Notes for Erosion Control.

V. BASIS OF PAYMENT

A. Maintain and Control Traffic. See Traffic Control Plan.

B. Guardrail. See Section 719.05.

C. Delineators for Guardrail. See the Sepia Drawing.

D. Erosion Control. See Special Notes for Erosion Control.

**SPECIAL NOTE FOR
ASPHALT MILLING AND TEXTURING**

Begin paving operations within **48 hours** of commencement of the milling operation. Continue paving operations continuously until completed. If paving operations are not begun within this time period, the Department will assess liquidated damages at the rate prescribed by Section 108.09 until such time as paving operations are begun.

Take possession of the millings and recycle the millings or dispose of the millings off the Right-of-Way at sites obtained by the Contractor at no additional cost to the Department.

1-3520 48 hours Contractor keeps millings
01/2/2012

SPECIAL NOTE FOR BASE FAILURE REPAIR

Repair locations listed on the summary are approximate only. The Engineer will determine actual repair locations and dimensions at the time of construction. Prior to overall milling and/or leveling and wedging, excavate the designated base failure areas to a depth 9 inches below the existing asphalt pavement surface level. Dispose of the excavated materials at waste sites off the Right-of-Way obtained by the Contractor at no additional cost to the Department. See Special Note for Waste and Borrow.

Backfill the excavated areas with Class 2 Asphalt Base 1.00D PG64-22. Compact the asphalt base to the compaction required in Section 403.03.10. Seal the asphalt base with leveling and wedging. Perform all base failure repairs in such a manner that removal and replacement are completed on the same day. Do this work as one of the Contractor's first operations in order to allow further compaction by traffic. Do not mill or place new asphalt surface over repaired base failure areas until a minimum of 7 calendar days have elapsed after placement of the asphalt base. After a minimum of 7 calendar days and when the Engineer determines the base failure repair areas have sufficiently stabilized, begin milling and/or resurfacing operations. Prior to milling and/or constructing the new asphalt surface, level and wedge any settlement of the repair areas.

The bidder must draw conclusions as to the conditions encountered. The Department does not give any guarantee as to the accuracy of the data and will not consider any claim for additional compensation if the materials encountered that are not in accord with the classification shown.

Accept payment at the Contract unit prices per square yard for Base Failure repair and per ton for Leveling and Wedging as full compensation for all labor, materials, equipment, and incidentals for removing pavement and disposing of the materials, furnishing and placing asphalt base, leveling and wedging, and all other items necessary to complete the work according to these notes to the satisfaction of the Engineer.

SPECIAL NOTE FOR TYPICAL SECTION DIMENSIONS

Consider the dimensions shown on the typical sections for pavement and shoulder widths and thickness' to be nominal or typical dimensions. The Engineer may direct or approve varying the actual dimensions to be constructed to fit existing conditions. Do not widen existing pavement or shoulders unless specified elsewhere in this proposal or directed by the engineer.

1-3725 Typical Section Dimensions
01/02/2012

TRAFFIC CONTROL PLAN
FD04 059 3716 000-002
FD05 059 3716 000-005

TRAFFIC CONTROL GENERAL

Except as provided herein, traffic shall be maintained in accordance with the current Standard Specifications and the Standard Drawings, current editions. Except for the roadway and traffic control bid items listed, all items of work necessary to maintain and control traffic will be paid at the lump sum bid price to "Maintain and Control Traffic".

Contrary to Section 106.01, traffic control devices used on this project may be new, or used in like new condition, at the beginning of the work and maintained in like new condition until completion of the work.

PROJECT PHASING & CONSTRUCTION PROCEDURES

The roadway may be closed during working hours for pipe replacement from 8 am to 5 pm. The contractor will have 8 working days to remove and install all culverts. The roadway shall be reopened at the end of each day. The Contractor is advised to take these restrictions into account in his bid. No additional payment will be allowed for any delays to the contractor as a result of these restrictions.

No lane closures will be allowed on the following days or nights:

July 3 & 4, 2022	Fourth of July
Sept. 4 & 5, 2022	Labor Day Weekend

At the discretion of the Engineer, other days and hours may be specified when lane closures will not be allowed.

Maintain a minimum of one traffic lane (mainline) in each direction at all times during construction except for pipe replacement. The clear lane width shall be 10 feet where possible. If traffic should be stopped due to construction operations, and a school bus on an official run arrives on the scene, the Contractor shall make provisions for the passage of the bus as quickly as possible.

Do not leave lane closures in place during non-working hours.

SIGNS

Sign posts and splices shall be compliant with NCHRP 350 or MASH. Manufacturer's documentation validating this compliance shall be provided to the Engineer prior to installation. Signs, including any splices, shall be installed according to manufacturer's specifications and installation recommendations. Contrary to section 112.04.02, only long-term signs (signs intended to be continuously in place for more than 3 days) will be measured for payment. Short-term signs

(signs intended to be left in place for 3 days or less) will not be measured for payment but will be incidental to Maintain and Control Traffic.

TEMPORARY ENTRANCES/ACCESS TO PROPERTY

The Contractor will not be required to provide continuous access to farms, single family, duplex, or triplex residential properties during working hours; however, provide reasonable egress and ingress to each such property when actual operations are not in progress at that location. The time during which a farm or residential entrance is blocked shall be the minimum length of time required for actual operations, shall not be extended for the Contractor's convenience, and in no case shall exceed six (6) hours. Notify all residents twenty-four hours in advance of any driveway or entrance closings and make any accommodations necessary to meet the access needs of disabled residents.

Except as allowed by the Phasing as specified above, maintain direct access to all side streets and roads, schools, churches, commercial properties and apartments or apartment complexes of four or more units at all times.

Payment will be allowed at the unit price bid for all asphalt materials required to construct and maintain any temporary entrances which may be necessary to provide temporary access; however, no direct payment will be allowed for aggregates, excavation and/or embankment needed. The Engineer will determine the type of surfacing material, asphalt or aggregate, to be used at each entrance.

BARRICADES

Barricades used in lieu of barrels and cones for channelization or delineation will be incidental to Maintain and Control Traffic according to Section 112.04.01. Barricades used to protect pavement removal areas will be bid as each according to Section 112.04.04.

TRAFFIC COORDINATOR

Furnish a Traffic Coordinator as per Section 112 for unclassified project.

TRAFFIC LOOP INSTALLATION

All items required for lane closures related to this item of work shall be considered incidental to bid item "Maintain and Control Traffic". Install Traffic signal loops as per special notes. The Contractor shall coordinate the placement of the traffic loops with the Traffic Engineer.

THERMOPLASTIC INTERSECTION MARKING

All items required for lane closures related to this item of work shall be considered incidental to bid item "Maintain and Control Traffic". The Contractor shall be required to locate, document, and replace the markings that are existing in the field upon completion of project or as directed by Engineer.

CHANGEABLE MESSAGE SIGNS

Provide changeable message signs in advance of and within the project at locations to be determined by the Engineer. If work is in progress concurrently in both directions or if more than one lane closure is in place in the same direction of travel, provide additional changeable message signs as directed by the Engineer. Place changeable message signs one mile in advance of the anticipated queue at each lane closure. As the actual queue lengthens and/or shortens relocate or provide additional changeable message signs so that traffic has warning of slowed or stopped traffic at least one mile but not more than two miles before reaching the end of the actual queue. The locations designated may vary as the work progresses. The messages required to be provided shall be designated by the Engineer. In the event of damage or mechanical/electrical failure, the Contractor shall repair or replace the Changeable Message Sign within 24 hours. The Department will measure for payment the maximum number of changeable message signs in concurrent use at the same time on a single day on all sections of the contract. Individual changeable message signs will be measured only once for payment, regardless of how many times they are set, reset, removed, and relocated during the duration of the project. Replacements for damaged changeable message signs directed by the Engineer to be replaced due to poor condition or readability will not be measured for payment.

ARROW PANEL

Use arrow panels as shown on the Standard Drawings or as directed by the Engineer. The Department will measure for payment the maximum number of arrow panels in concurrent use at the same time on a single day on all sections of the contract. Individual arrow panels will be measured only once for payment, regardless of how many times they are set, reset, removed, and relocated during the duration of the project. Replacements for damaged arrow panels directed by the Engineer to be replaced due to poor condition or readability will not be measured for payment. Arrow panels will remain the property of the Contractor after construction is complete.

PAVEMENT MARKINGS

Coordinate the installation of all temporary and permanent striping with the Resident Engineer, and the TEBM for Traffic in the District. If there is a deviation from the existing striping plan, a striping plan for the pavement shall be provided to the Contractor prior to the installation of any temporary or permanent markings.

Do not install temporary pavement striping, permanent pavement striping, and/or thermoplastic or Durable Pavement markings without written permission from the Engineer.

Temporary Striping will be installed as per Section 112 with the following exceptions:

Temporary striping shall include striping of the edgelines.

Temporary or Permanent striping shall be in place before a lane is opened to traffic

If the Contractor's operations or phasing requires temporary markings that must be subsequently removed from the final surface course, an approved "Removable Lane Tape" shall be used. This removable lane tape will not be measured separately. The "removable lane tape", if used, will be measured and paid as temporary striping.

PAVEMENT EDGE DROP-OFFS

A pavement edge between opposing directions of traffic or lanes that traffic is expected to cross in a lane change situation shall not have an elevation difference greater than 1½". Warning signs (MUTCD W8-9 or W8-9A, or W8-11) shall be placed in advance of and at 1500' intervals throughout the drop-off area. Dual posting on both sides of the traveled way shall be required. All transverse transitions between the newly surfaced area and the existing surface areas that traffic may cross shall be wedged with asphalt mixture for leveling and wedging. The wedges shall be removed prior to placement of the final surface course.

Pavement edges that traffic is not expected to cross, except accidentally, shall be treated as follows:

Less than 2" - No protection required.

2" to 4" - Place plastic drums, vertical panels, or barricades every 50 feet. Cones may be used in place of plastic drums, panels, and barricades during daylight working hours only. Wedge with asphalt mixture for leveling and wedging with a 1:1 or flatter slope in daylight hours, or 3:1 or flatter slope during nighttime hours, when work is not active in the drop-off area.

Greater than 4 inches - Drop-offs exceeding 4 inches will be allowed only during active operations during the interval between removal of shoulder/traffic islands/medians and the placement of the asphalt base courses in these areas. Place plastic drums, vertical panels or barricades every 40 feet. Drop-offs less than eight feet behind a lane or shoulder closure shall be protected by a asphalt wedge with 3:1 or flatter slope; the wedge shall be removed and the base course placed in the drop-off area as soon as possible.

In lieu of a wedge, drop-offs at lateral trenches may be covered by a 1" thick steel plate when work is not actively in progress at the pavement removal area; the plate shall be anchored to the pavement by any method approved by the Engineer that will prevent it being dislodged by accidental impact. If for any reason, it is necessary to excavate small areas, any holes adjacent to traffic where there exists a possibility that a vehicle may drop a wheel into the holes shall be filled with asphalt or plated. No direct payment will be made for the wedge or steel plates, but shall be incidental to other items of work.

DURABLE PAVEMENT EDGE DETAIL

(Resurfacing adjacent to fill slope or ditch foreslope that is 3:1 or less)

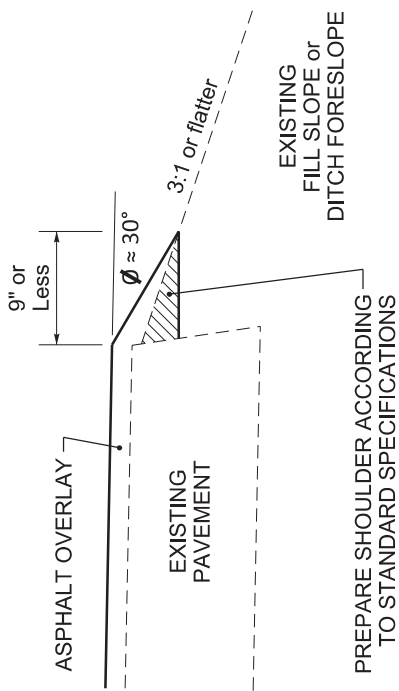

DURABLE PAVEMENT EDGE DETAIL

(Resurfacing adjacent to fill slope or ditch foreslope that is steeper than 3:1)

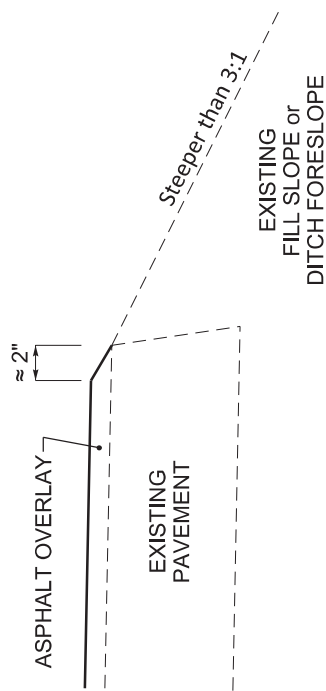

NOTES

1. DETAILS DO NOT APPLY TO OVERLAYS LESS THAN 1 INCH THICK.
2. THE DURABLE PAVEMENT EDGE DEVICE MAY BE DISENGAGED AT DRIVEWAYS, SIDE STREETS, HIGH SHOULDERS, AND OTHER LOCATIONS NOT FEASIBLE TO CONSTRUCT, AS APPROVED BY THE ENGINEER.

DURABLE PAVEMENT EDGE
DETAILS

DRAWING NOT TO SCALE

DURABLE PAVEMENT EDGE DETAIL

(Resurfacing adjacent to low shoulder with dropoff of 5 inches or less)

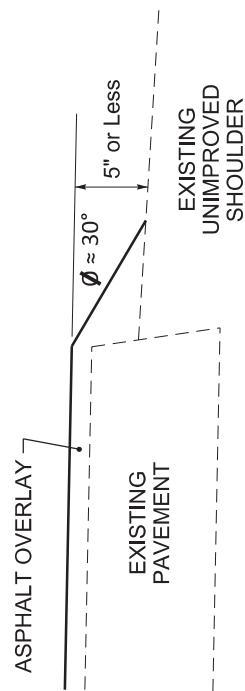

DURABLE PAVEMENT EDGE DETAIL

(Resurfacing adjacent to low shoulder with dropoff of more than 5 inches)

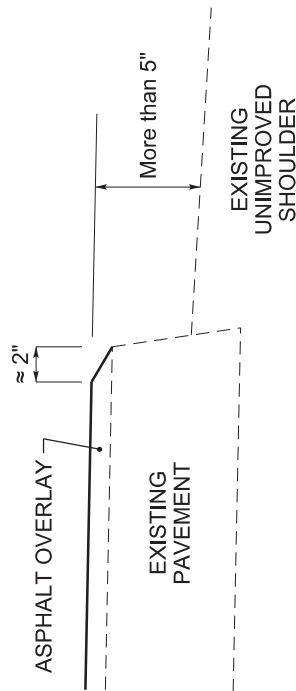

DURABLE PAVEMENT EDGE DETAIL

(Resurfacing adjacent to an obstruction, such as an existing headwall)

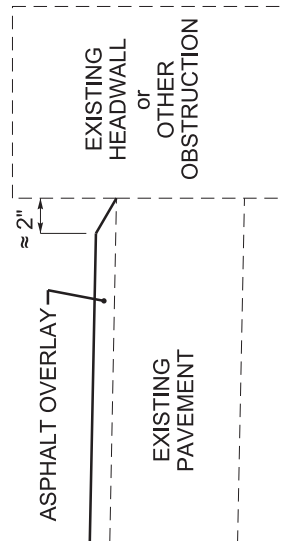

SPECIAL NOTE FOR TRAFFIC SIGNAL LOOP DETECTORS

1.0 DESCRIPTION. Be advised that there are existing traffic signal loop detectors within the construction limits of this project. Except as specified herein, perform traffic signal loop replacement in accordance with the Department's Standard/Supplemental Specifications, Special Provisions, Special Notes, and Standard/Sepia Drawings, current editions and as directed by the Engineer. Article references are to the Standard Specifications. Furnish all materials, labor, equipment, and incidentals for replacement of traffic signal loop installation(s) and all other work specified as part of this contract.

1.1 Pre-bid Requirements. Conform to Subsection 723.03.17

2.0 MATERIALS. Except as specified herein, furnish materials in accordance with Subsection 732.02 and Section 835. Provide for materials to be sampled and tested in accordance with the Department's Sampling Manual. Make materials available for sampling a sufficient time in advance of the use of the materials to allow for the necessary time for testing, unless otherwise specified in this Special Note.

2.1 Maintain and Control Traffic. See Traffic Control Plan.

2.2 Sand. Furnish natural sand meeting the requirements of Subsection 804.04.01.

2.3 Seeding. Furnish Seed Mix Type I.

2.4 Loop Saw Slot and Fill. Furnish loop sealant, backer rod, and non-shrink grout according to the Saw Slot Detail.

2.5 Junction Boxes. Furnish junction box type B, #57 aggregate, and geotextile filter type IV according to junction box detail.

2.6 Cable No. 14/1 Pair (Lead-in). Furnish cable that is specified in Section 835. Cable shall be ran splice free. This shall include splice kits to connect to the loop wire.

2.7 Conduit. Furnish and install appropriate conduit from transitions to the roadway, junction boxes and poles. See details below.

3.0 CONSTRUCTION. Except as specified herein, install and test Traffic Signal Loop Detectors in accordance with Section 723 and the drawings.

3.1 Testing. Conform to Subsection 723.03.17 (A)

3.2 Coordination. Conform to Subsection 723.03.17 (B)

3.3 Connection. Conform to Subsection 723.03.17 (C)

3.4 Maintain and Control Traffic. See Traffic Control Plan.

3.5 Milling. Conform to Subsection 723.03.17 (F)

3.6 Loop Saw Slot and Fill. Conform to Subsection 723.03.13 (A).

Traffic Signal Loop Detectors
Page 2 of 9

3.7 Backfilling and Disturbed Areas. Conform to Subsection 723.03.11.

3.8 Removal. Conform to Subsection 723.03.16.

3.9 Property/Roadway Damage. Conform to Subsection 723.03.17 (J).

3.10 Right-of-Way Limits. Conform to Subsection 723.03.17 (K).

3.11 Utility Clearance. Conform to Subsection 716.03.01.

3.12 Control. Obtain the Engineer’s approval of all designs required to be furnished by the Contractor prior to incorporation into the work. The Department reserves the right to permit other contractors, state forces, public utility companies, and others to do work during the construction within the limits of, or adjacent to, the project. Conduct operations and cooperate with such other parties so that interference with each other’s work will be reduced to a minimum. The Contractor agrees to make no claims against the Department for additional compensation due to delays or other conditions created by the operations of such other parties. Should a difference of opinion arise as to the rights of the Contractor and others working within the limits of, or adjacent to, the project, the Engineer will decide as to the respective rights of the various parties involved in order to ensure the completion of the work in general harmony and in a satisfactory manner, and the Engineer’s decision shall be final and binding upon the Contractor.

3.13 Bore and Jack. Conform to Subsection 723.03.06 (I).

3.14 Open Cut Roadway. Conform to Subsection 723.03.06 (I).

4.0 MEASUREMENT. See Subsection 723.04 for bid item notes. Additional bid items include the following:

4.1 Loop Test. The Department will measure the quantity as each individual unit loop tested. The Department will not measure disconnection, reconnection, traffic control, re-splicing per specifications, before and after testing per note above, and any associated hardware for payment and will consider them incidental to this item of work.

4.2 Remove Signal Equipment. The department will measure the quantity by each. The department will not measure backfilling and the disposal or transportation of equipment and materials associated with any structural or electrical component of the signal system including, but not limited to pole bases, poles, junction boxes, cabinets, and wood poles for payment and will consider them incidental to this item of work.

5.0 PAYMENT. The Department will make payment for the completed and accepted quantities of listed items according to Subsection 723.05 in addition to the following:

<u>Code</u>	<u>Pay Item</u>	<u>Pay Unit</u>
Conduit 1”	4792	Linear Foot
PVC Conduit – 1 ¼ inch – sch 80	24900EC	Linear Foot

Traffic Signal Loop Detectors
Page 3 of 9

PVC Conduit – 2 inch – sch 80	24901EC	Linear Foot
Conduit 2”	4795	Linear Foot
Electrical Junction Box type B	4811	Each
Loop Test	24963ED	Each
Trenching and Backfilling	4820	Linear Foot
Loop Wire	4830	Linear Foot
Cable-No. 14/1 Pair	4850	Linear Foot ¹
Loop Saw Slot and Fill	4895	Linear Foot ¹
Bore and Jack Conduit	21543EN	Linear Foot ³
Open Cut Roadway	4821	Linear Foot ³
Remove Signal Equipment	24955ED	each

The Department will consider payment as full compensation for all work required under these notes and the Standard Specifications.

Contrary to section 723:

SUBSECTION: 03.13 Loop Installation.

REVISION: Replace first sentence note with the following:

twist unshielded loop wire (imsa 51-7) with 3 to 5 turns from the start of homerun to the inside conduit, junction box, cabinet, or pole. Twist unshielded loop wires (imsa 51-7) with 3 to 5 turns per foot from the start of the homerun to the junction box, cabinet, or pole. Slot can be widen to .5" to .625" to help with the installation of the twisted wire.

Traffic Signal Loop Detectors

Page 4 of 9

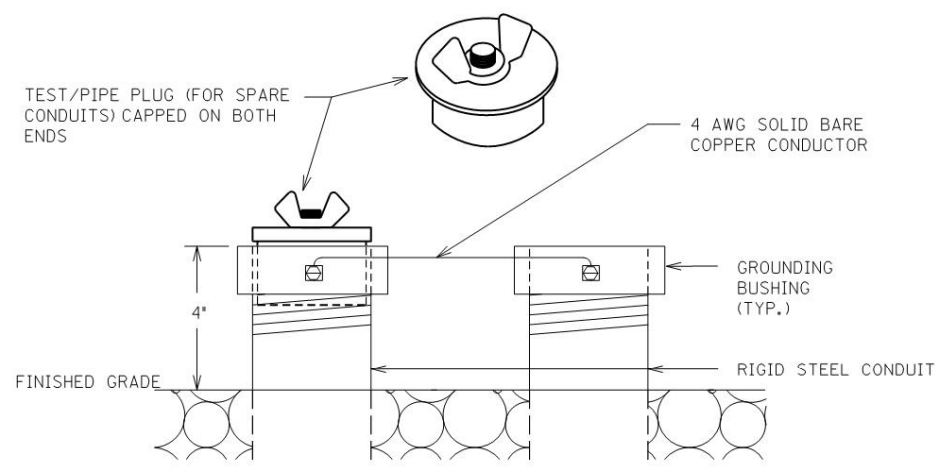

TEST/PIPE PLUG(FOR SPARE CONDUITS) AND GROUNDING DETAIL

Traffic Signal Loop Detectors

Page 5 of 9

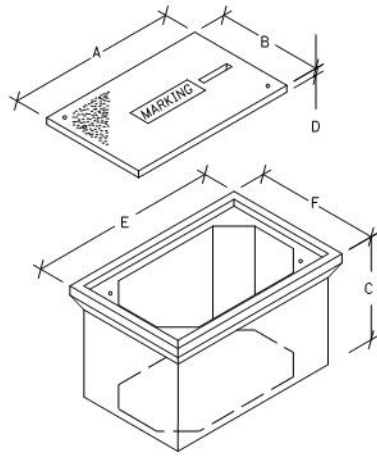

JUNCTION BOX DIMENSIONS (NOMINAL)						
	A	B	C	D	E	F
TYPE A	23"	14"	27"	2"	25"	15"
TYPE B	18"	11"	12"	1 3/4"	20"	13"
TYPE C	36"	24"	30"	3"	38"	26"

• MINIMUM
NOTE: STACKABLE BOXES ARE PERMITTED

BEFORE THE INSTALLATION OF THE #57 AGGREGATE AND JUNCTION BOX, THE CONTRACTOR SHALL INSTALL GEOTEXTILE FILTER FABRIC TYPE IV IN THE HOLE. THE FABRIC SHALL EXTEND TO JUST BELOW THE LIP OF THE JUNCTION BOX AND SHALL BE CONTINUOUSLY ADHERED TO THE EXTERIOR OF THE BOX WITH ADHESIVE. ANY LOCATIONS WHERE CONDUITS ENTER THE BOX, THE FABRIC SHALL BE 'X CUT' ONLY AS MUCH AS NECESSARY TO ALLOW PASSAGE OF EACH INDIVIDUAL CONDUIT THROUGH THE FABRIC. THE FABRIC SHALL BE INCIDENTAL TO BID ITEMS 481I, 2039INS835, OR 20392NS835.

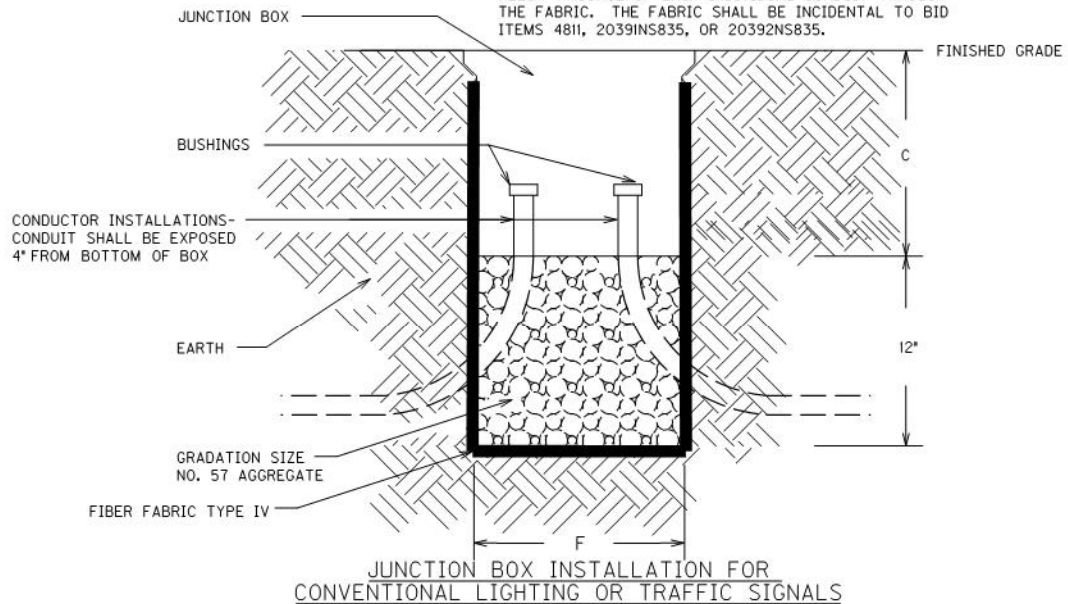

JUNCTION BOX INSTALLATION FOR CONVENTIONAL LIGHTING OR TRAFFIC SIGNALS

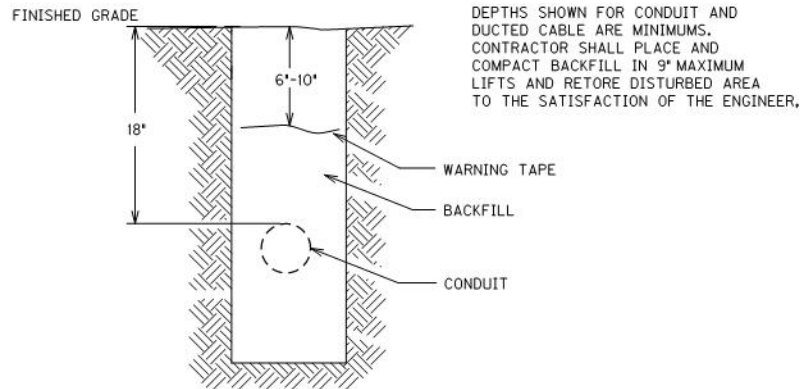

CONDUIT AND WARNING TAPE TRENCH

Traffic Signal Loop Detectors

Page 6 of 9

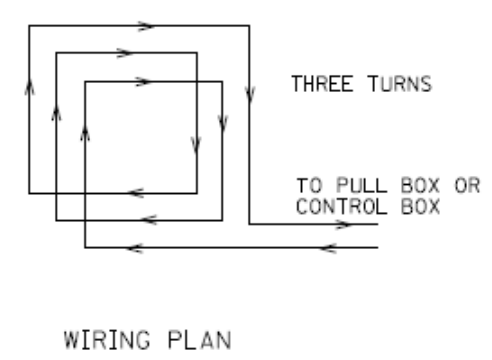
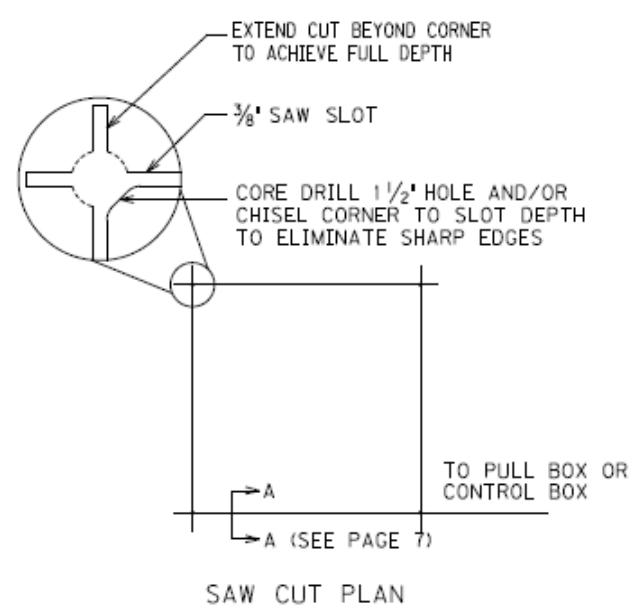

6'X6' LOOP

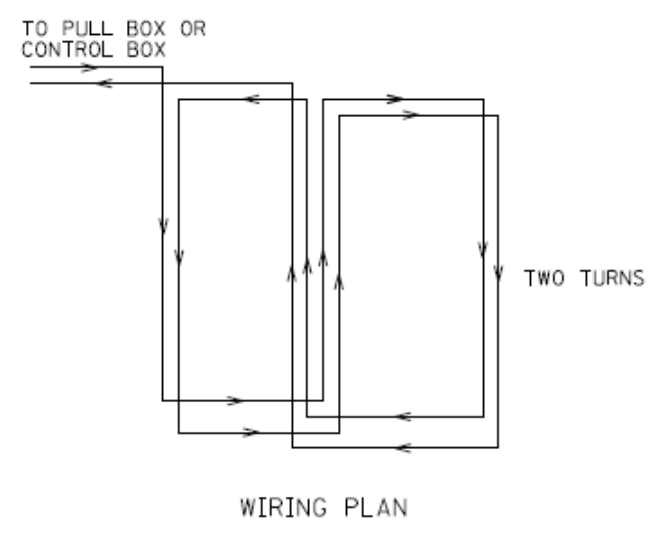
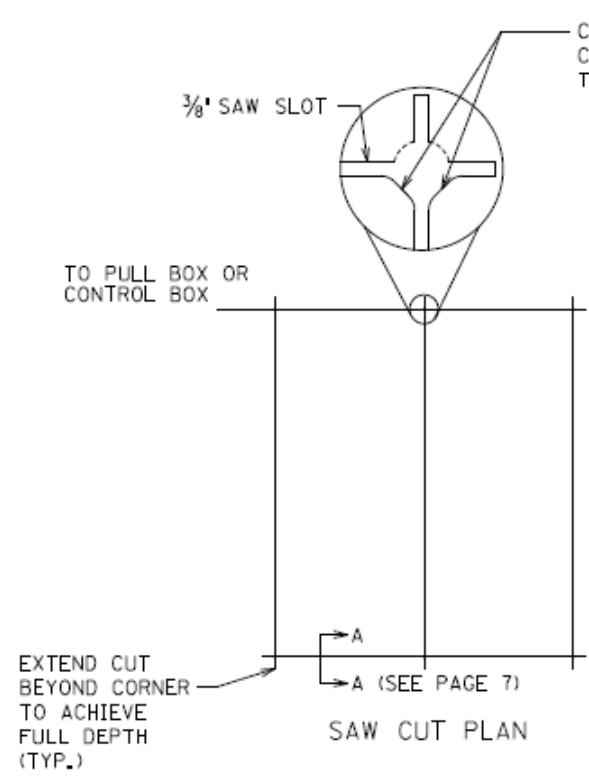

6'X30' QUADRAPOLE LOOP

Traffic Signal Loop Detectors

Page 7 of 9

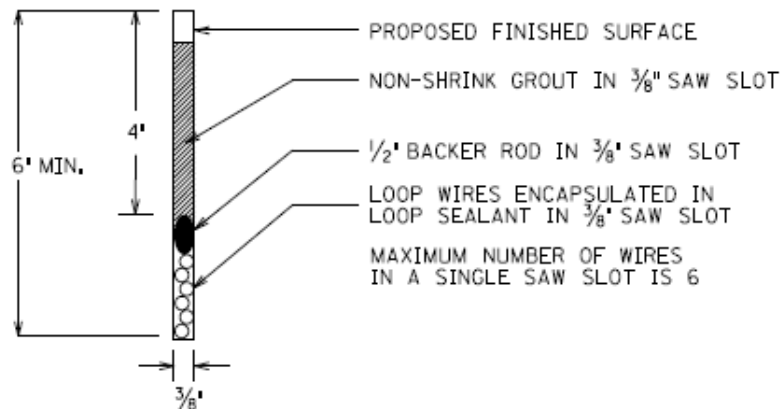

SECTION A-A (SAW SLOT DETAIL)

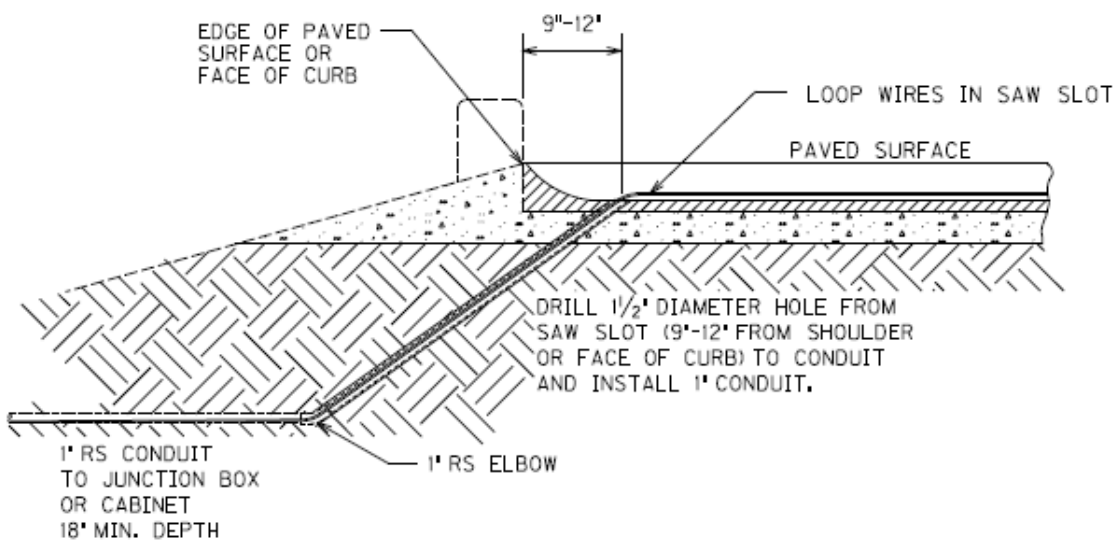

SAW SLOT EDGE OF PAVEMENT TRANSITION

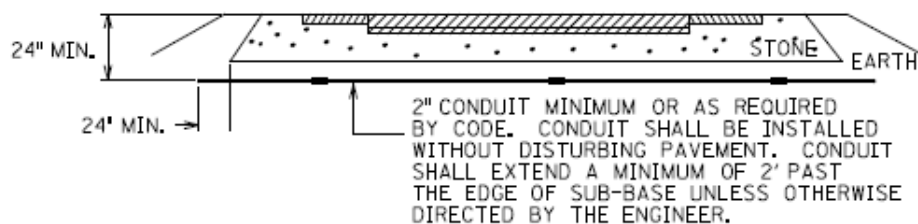

CONDUIT UNDER EXISTING PAVEMENT DETAIL

Traffic Signal Loop Detectors

Page 8 of 9

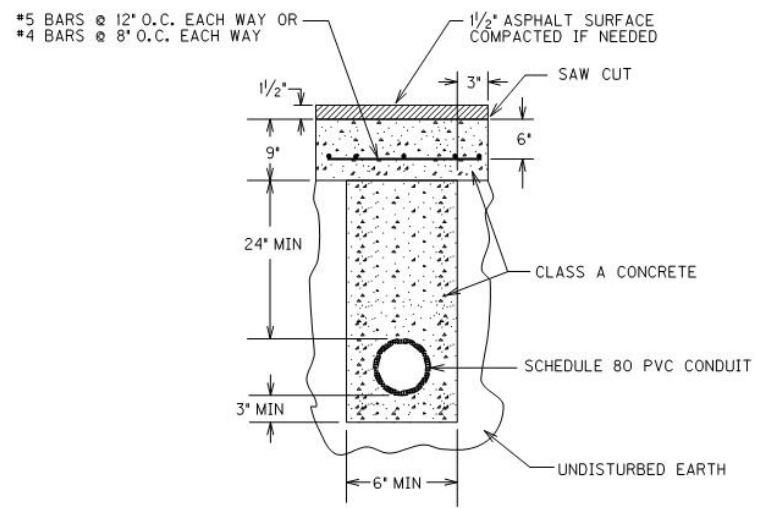

OPEN CUT PAVEMENT DETAIL

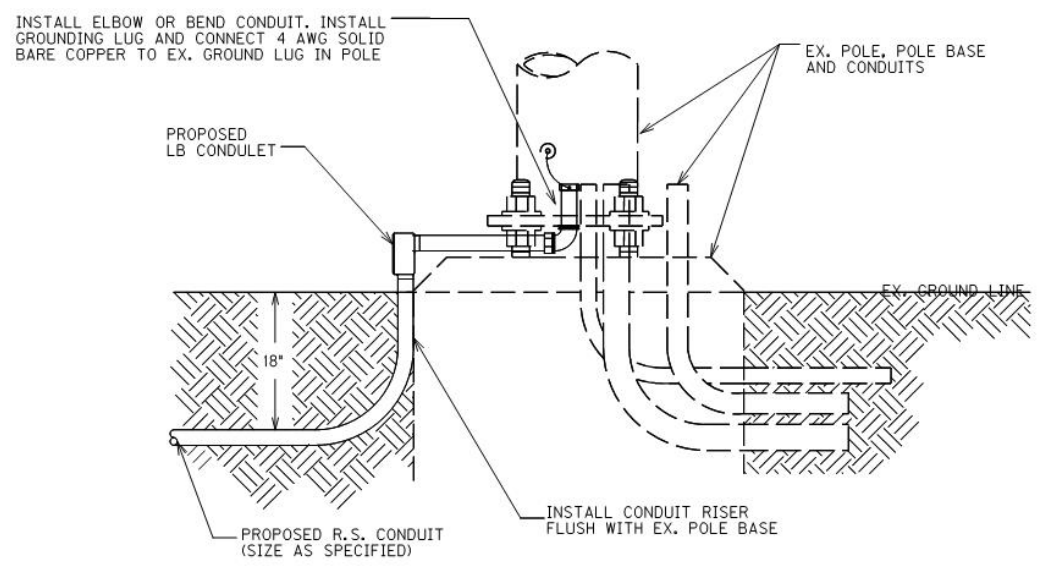

CONDUIT INSTALLATION IN EX. POLE BASE

Traffic Signal Loop Detectors

Page 9 of 9

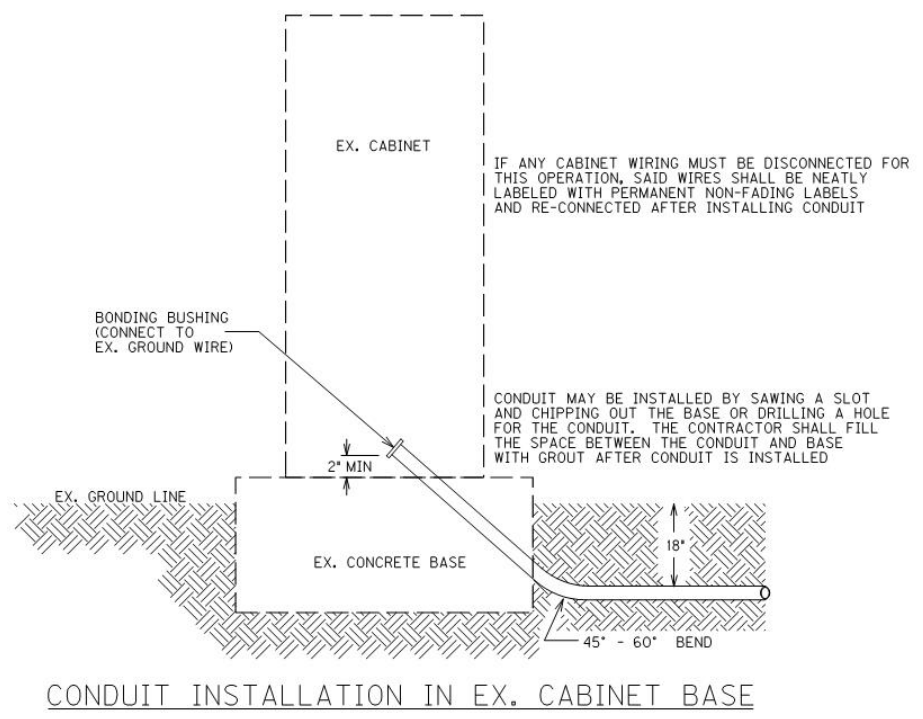

Update: 4-5-2022

SPECIAL NOTE FOR EROSION CONTROL

I. DESCRIPTION

Perform all erosion and water pollution control work in accordance with the Department's Standard and Interim Supplemental Specifications, Special Provisions and Special Notes, and Standard and Sepia Drawings, current editions, and as directed by the Engineer. Section references are to the Standard Specifications. This work shall consist of:

(1) Developing and preparing a Best Management Practices Plan (BMP) tailored to suit the specific construction phasing for each site within the project; (2) Preparing the project site for construction, including locating, furnishing, installing, and maintaining temporary and/or permanent erosion and water pollution control measures as required by the BMP prior to beginning any earth disturbing activity on the project site; (3) Clearing and grubbing and removal of all obstructions as required for construction; (4) Removing all erosion control devices when no longer needed; (5) Restoring all disturbed areas as nearly as possible to their original condition; (6) Preparing seedbeds and permanently seeding all disturbed areas; (7) Providing a Kentucky Erosion Prevention and Sediment Control Program (KEPSC-RI) qualified inspector; and (8) Performing any other work to prevent erosion and/or water pollution as specified by this contract, required by the BMP, or as directed by the Engineer.

II. MATERIALS

Furnish materials in accordance with these notes, the Standard Specifications and Interim Supplemental Specifications, and applicable Special Provisions and Special Notes, and Standard and Sepia Drawings, current editions. Provide for all materials to be sampled and tested in accordance with the Department's Sampling Manual. Unless directed otherwise by the Engineer, make the materials available for sampling a sufficient time in advance of the use of the materials to allow for the necessary time for testing.

III. CONSTRUCTION

Be advised, these Erosion Control Plan Notes do not constitute a BMP plan for the project. Jointly with the Engineer, prepare a site specific BMP plan for each drainage area within the project in accordance with Section 213. Provide a unique BMP at each project site using good engineering practices taking into account existing site conditions, the type of work to be performed, and the construction phasing, methods and techniques to be utilized to complete the work. Be responsible for all erosion prevention, sediment control, and water pollution prevention measures required by the BMP for each site. Represent and warrant compliance with the Clean Water Act (33 USC Section 1251 et seq.), the 404 Permit, the 401 Water Quality Certification, and applicable state and local government agency laws, regulations, rules, specifications, and permits. Contrary to Section 105.05, in case of discrepancy between these notes, the Standard Specifications, Interim Supplemental Specifications, Special and Special Notes, Standard and Sepia Drawings, and such state and local government agency requirements, adhere to the most restrictive requirement.

Erosion Control Page 2 of 3

Conduct operations in such a manner as to minimize the amount of disturbed ground during each phase of the construction and limit the haul roads to the minimum required to perform the work. Preserve existing vegetation not required to be removed by the work or the contract. Seed and/or mulch disturbed areas at the earliest opportunity. Use silt fence, silt traps, temporary ditches, brush barriers, erosion control blankets, sodding, channel lining, and other erosion control measures in a timely manner as required by the BMP and as directed or approved by the Engineer. Prevent sediment laden water from leaving the project, entering an existing drainage structure, or entering a stream.

Provide for erosion control measures to be in place and functioning prior to any earth disturbance within a drainage area. Compute the volume and size of silt control devices necessary to control sediment during each phase of construction. Remove sediment from silt traps before they become a maximum of ½ full. Maintain silt fence by removing accumulated trappings and/or replacing the geotextile fabric when it becomes clogged, damaged, or deteriorated, or when directed by the Engineer. Properly dispose of all materials trapped by erosion control devices at approved sites off the right of way obtained by the Contractor at no additional cost to the Department (See Special Note for Waste and Borrow).

As work progresses, add or remove erosion control measures as required by the BMP applicable to the Contractor's project phasing and construction methods and techniques. Update the volume calculations and modify the BMP as necessary throughout the duration of the project. Ensure that an updated BMP is kept on site and available for public inspection throughout the life of the project.

After all construction is complete, restore all disturbed areas in accordance with Section 212. Completely remove all temporary erosion control devices not required as part of the permanent erosion control from the construction site. Prior to removal, obtain the Engineer's concurrence of items to be removed. Grade the remaining exposed earth (both on and off the Right-of-Way) as nearly as possible to its original condition, or as directed by the Engineer. Prepare the seed bed areas and sow all exposed earthen areas with the applicable seed mixture(s) according to Section 212.03.03.

IV. MEASUREMENT

Erosion Control Blanket. If required by the BMP, the Department will measure Erosion Control Blanket according to Section 212.04.07.

Sodding. If required by the BMP, the Department will measure Sodding according to Section 212.04.08.

Channel Lining. If required by the BMP, the Department will measure Channel Lining according to Sections 703.04.04-703.04.07.

Erosion Control. Contrary to Sections 212.04, 213.04, and 703.04 other than Erosion Control Blankets, Sodding, and Channel Lining, the Department will measure Erosion Control as one lump sum. The Department will not measure developing, updating, and maintaining a BMP plan for each site; providing a KEPSC-RI qualified inspector; locating,

Erosion Control
Page 3 of 3

furnishing, installing, inspecting, maintaining, and removing erosion and water pollution control items; Roadway Excavation, Borrow Excavation, Embankment In Place, Topsoil Furnished and Placed, and Spreading Stockpiled Topsoil; Topdressing Fertilizer, Temporary and Permanent Seeding and Protection, Special Seeding Crown Vetch, and Temporary Mulch; Sedimentation Basin and Clean Sedimentation Basin, Silt Trap Type "A" and Clean Silt Trap Type "A"; Silt Trap Type "B" and Clean Silt Trap Type "B"; Silt Trap Type "C" and Clean Silt Trap Type "C"; Temporary Silt Fence and Clean Temporary Silt Fence; Plants, Vines, Shrubs, and Trees; Gabion and Dumped Stone Deflectors and Riffle Structures; Boulders; Temporary Ditches and clean Temporary Ditches; Geotextile Fabric, and all other erosion and water pollution control items required by the BMP or the Engineer, but shall be incidental to Erosion Control.

V. Basis of Payment

Erosion Control Blanket. If not listed as a bid item, but required by the BMP, the Department will pay for Erosion Control Blankets as Extra Work according to Sections 104.03 and 109.04.

Sodding. If not listed as a bid item, but required by the BMP, the Department will pay for Sodding as Extra Work according to Sections 104.03 and 109.04.

Channel Lining. If not listed as a bid item, but required by the BMP, the Department will pay for Channel Lining as Extra Work according to Sections 104.03 and 109.04.

Erosion Control. Contrary to Sections 212.05 and 213.05, other than Erosion Control Blanket, Sodding, and Channel Lining, payment at the Contract lump sum price for Erosion Control, shall be full compensation for all materials, equipment, labor and incidentals necessary to complete the erosion and water pollution control work as specified in these notes, Sections 212 and 213, the Supplemental Specifications, applicable Special Provisions and Special Notes, and Standard and Sepia Drawings, including but not limited to developing, updating, and maintaining a BMP plan for each site; providing a KEPSC-RI qualified inspector; locating, furnishing, installing, inspecting, maintaining, and removing erosion and water pollution control items; Roadway Excavation, Borrow Excavation, Embankment In Place, Topsoil Furnished and Placed, and Spreading Stockpiled Topsoil; Topdressing Fertilizer, Temporary and Permanent Seeding and Protection, Special Seeding Crown Vetch, and Temporary Mulch; Sedimentation Basin and Clean Sedimentation Basin, Silt Trap Type "A" and Clean Silt Trap Type "A"; Silt Trap Type "B" and Clean Silt Trap Type "B"; Silt Trap Type "C" and Clean Silt Trap Type "C"; Temporary Silt Fence and Clean Temporary Silt Fence; Plants, Vines, Shrubs, and Trees; Gabion and Dumped Stone Deflectors and Riffle Structures; Boulders; Temporary Ditches and clean Temporary Ditches; Geotextile Fabric and all other erosion and water pollution control items required by the BMP or the Engineer.

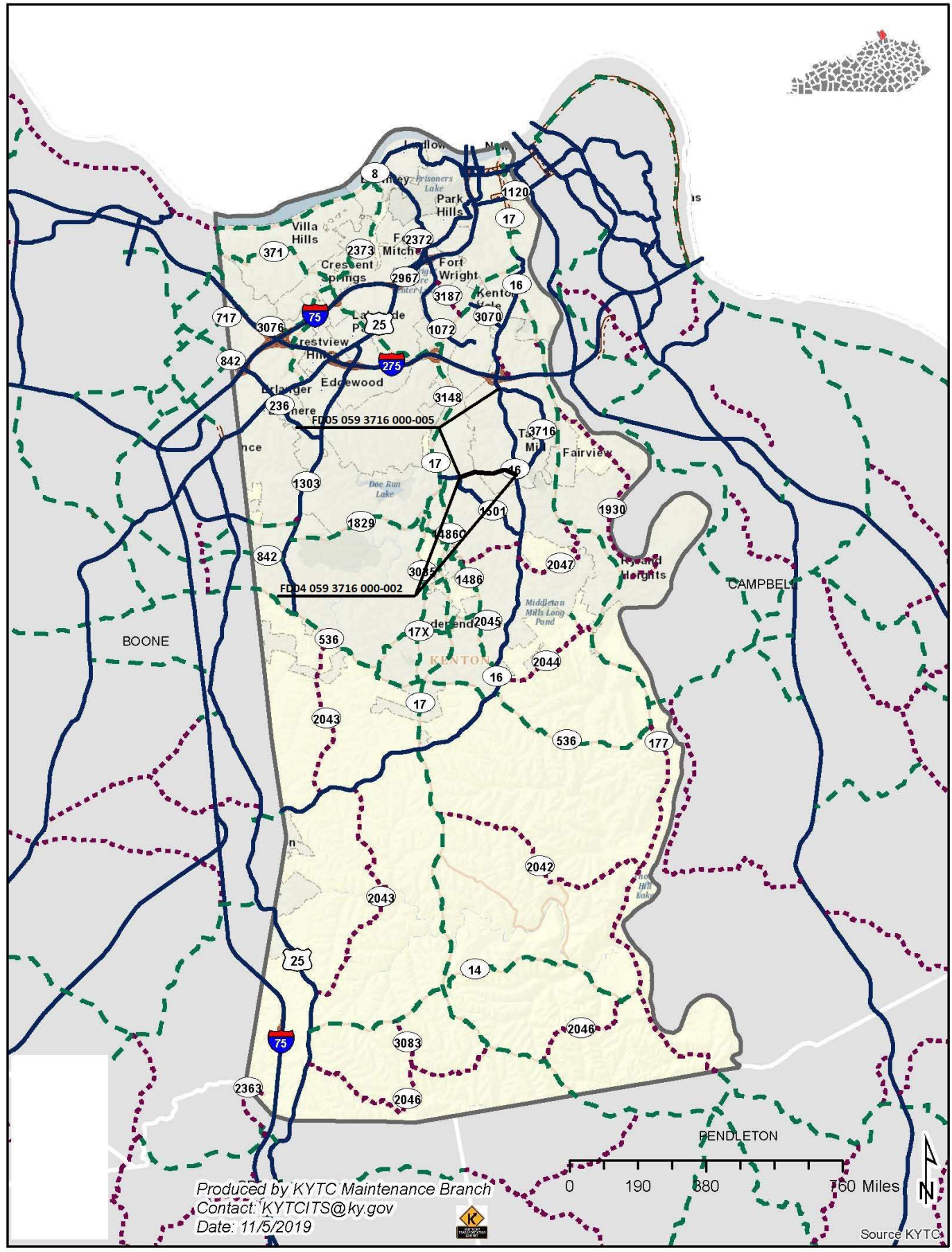

Produced by KYTC Maintenance Branch
Contact: KYTCITS@ky.gov
Date: 11/5/2019



Source KYTC

MATERIAL SUMMARY

CONTRACT ID: 222441

059GR22P057 - FD05 & FD04

MP05937162201

TAYLOR MILL ROAD (KY 3716) BEGINNING AT KY 1501 EXTENDING NORTH TO KY 16. ASPHALT RESURFACING, A DISTANCE OF 4.27 MILES.

Project Line No	Bid Code	DESCRIPTION	Quantity	Unit
0005	00190	LEVELING & WEDGING PG64-22	140.00	TON
0010	00356	ASPHALT MATERIAL FOR TACK	31.00	TON
0015	00388	CL3 ASPH SURF 0.38B PG64-22	4,825.00	TON
0020	02562	TEMPORARY SIGNS	990.00	SQFT
0025	02650	MAINTAIN & CONTROL TRAFFIC	1.00	LS
0030	02671	PORTABLE CHANGEABLE MESSAGE SIGN	2.00	EACH
0035	02676	MOBILIZATION FOR MILL & TEXT	1.00	LS
0040	02677	ASPHALT PAVE MILLING & TEXTURING	4,825.00	TON
0045	02775	ARROW PANEL	2.00	EACH
0050	03240	BASE FAILURE REPAIR	395.00	SQYD
0055	04793	CONDUIT-1 1/4 IN	50.00	LF
0060	04811	ELECTRICAL JUNCTION BOX TYPE B	1.00	EACH
0065	04830	LOOP WIRE	1,470.00	LF
0070	04850	CABLE-NO. 14/1 PAIR	50.00	LF
0075	04895	LOOP SAW SLOT AND FILL	610.00	LF
0080	06510	PAVE STRIPING-TEMP PAINT-4 IN	90,330.00	LF
0085	06515	PAVE STRIPING-PERM PAINT-6 IN	90,330.00	LF
0090	06565	PAVE MARKING-THERMO X-WALK-6 IN	860.00	LF
0095	06568	PAVE MARKING-THERMO STOP BAR-24IN	300.00	LF
0100	06569	PAVE MARKING-THERMO CROSS-HATCH	58.00	SQFT
0105	06574	PAVE MARKING-THERMO CURV ARROW	23.00	EACH
0110	06575	PAVE MARKING-THERMO COMB ARROW	1.00	EACH
0115	06600	REMOVE PAVEMENT MARKER TYPE V	108.00	EACH
0120	10020NS	FUEL ADJUSTMENT	7,728.00	DOLL
0125	10030NS	ASPHALT ADJUSTMENT	19,411.00	DOLL
0130	02569	DEMOBILIZATION	1.00	LS

MATERIAL SUMMARY

CONTRACT ID: 222441

059GR22P057 - FD05 & FD04

MP05937162202

WAYMANS BRANCH (KY 3716) BEGIN AT KY 1501 EXTENDING EAST TO HIGHBRIDGE DRIVE/OLD WAYMAN BRANCH ROAD CULVERT REPLACEMENT, A DISTANCE OF 1.32 MILES.

Project Line No	Bid Code	DESCRIPTION	Quantity	Unit
0135	00221	CL2 ASPH BASE 0.75D PG64-22	500.00	TON
0140	00462	CULVERT PIPE-18 IN	102.00	LF
0145	00464	CULVERT PIPE-24 IN	288.00	LF
0150	00468	CULVERT PIPE-36 IN	40.00	LF
0155	01987	DELINEATOR FOR GUARDRAIL BI DIRECTIONAL WHITE	40.00	EACH
0160	02014	BARRICADE-TYPE III	10.00	EACH
0165	02220	FLOWABLE FILL	100.00	CUYD
0170	02351	GUARDRAIL-STEEL W BEAM-S FACE	1,887.50	LF
0175	02367	GUARDRAIL END TREATMENT TYPE 1	12.00	EACH
0180	02381	REMOVE GUARDRAIL	1,800.00	LF
0185	02483	CHANNEL LINING CLASS II	250.00	TON
0190	02562	TEMPORARY SIGNS	190.00	SQFT
0195	02575	DITCHING AND SHOULDERING	6,320.00	LF
0200	02610	RETAINING WALL-GABION	48.00	CUYD
0205	02650	MAINTAIN & CONTROL TRAFFIC	1.00	LS
0210	02671	PORTABLE CHANGEABLE MESSAGE SIGN	2.00	EACH
0215	02690	SAFELOADING	5.00	CUYD
0220	03271	TREE TRIMMING	4,800.00	LF
0225	08100	CONCRETE-CLASS A	2.00	CUYD
0230	02569	DEMOBILIZATION	1.00	LS

**Kenton County
 TRAFFIC LOOP SUMMARY
 FD05 059 3716 000-005**

MPT.	INTERSECTION	SAW, SLOT AND FILL		LOOP WIRE		CONDUIT		CABLE		JUNCTION		NOTES
		LF		LF		LF		LF		EA		
4.12	OLD TAYLOR MILL RD	610		1470		50		50		1		2 Left Turn Loops, 3 Loops on Old Taylor Mill
TOTAL		610		1470		50		50		1		0

NOTES: OMIT LOOPS AT BOTH KY 16 INTERSECTIONS.

KENTON COUNTY
FD04 059 3716 000-002
TYPICAL PIPE X-SECTION
MP 0.000 - 1.322

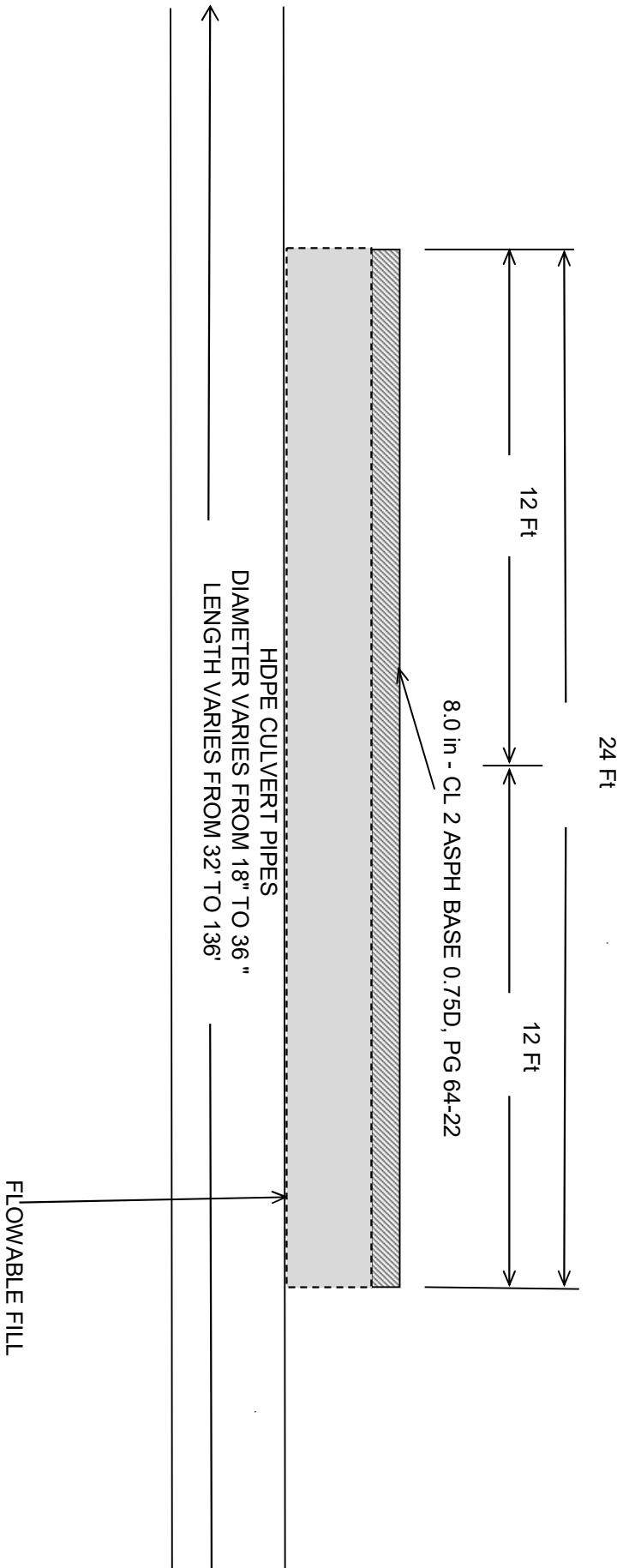

KENTON COUNTY
FD05 059 3716 000-005
TYPICAL SECTION

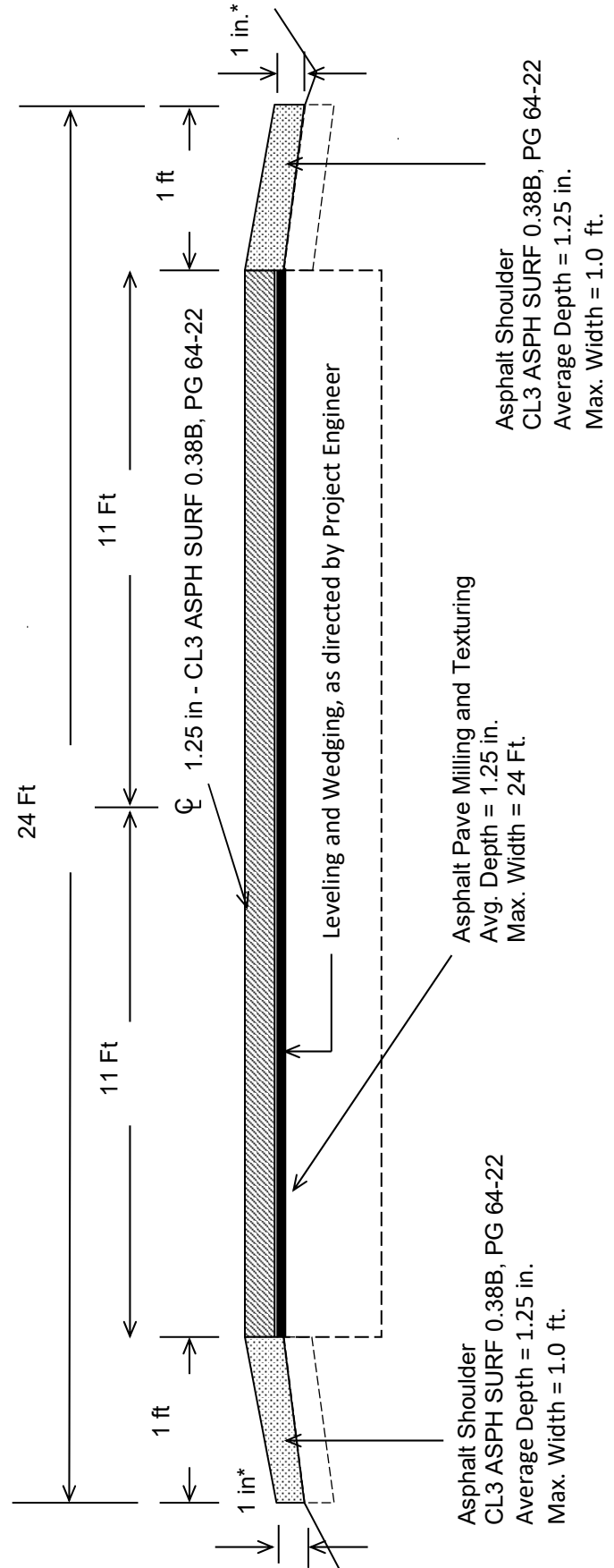

***Where Existing Site Conditions Permit**

TYPICAL SECTION

KENTON COUNTY
FD05 059 3716 000-005
MP 1.322 - 1.619 & MP 3.994 - 4.277

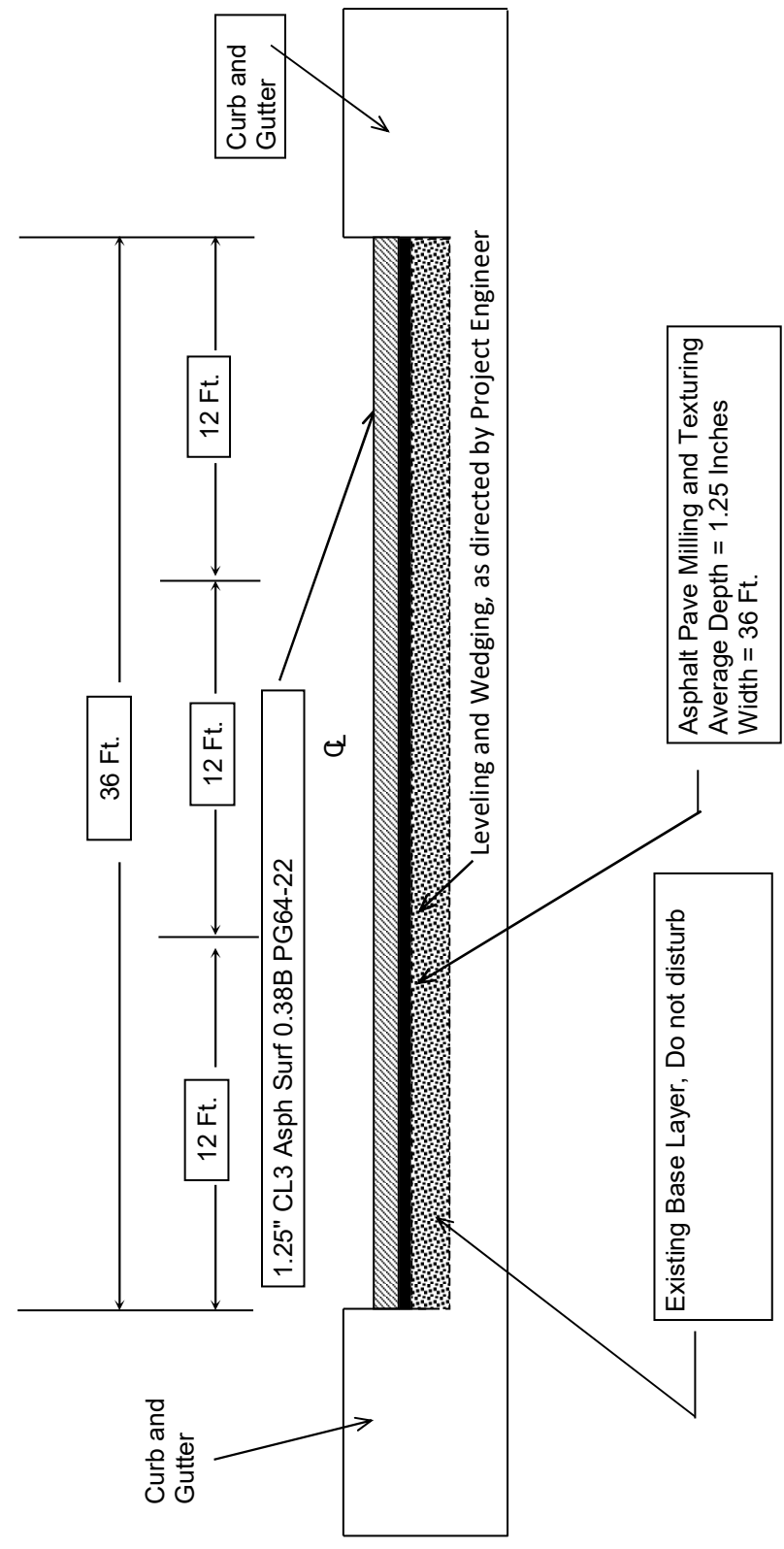

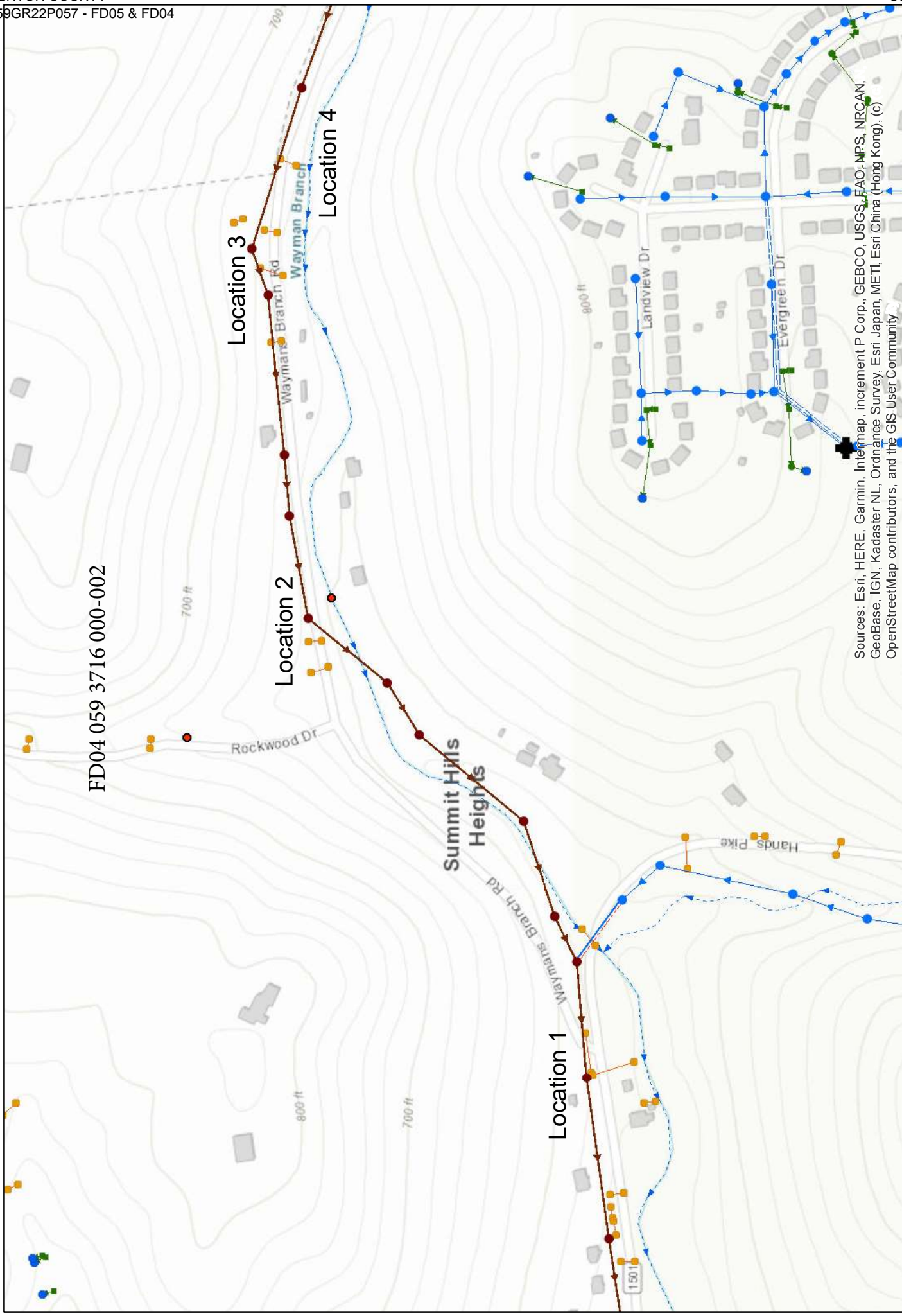

FD04 059 3716 000-002

Location 3
Location 4

Location 2

Location 1

Sources: Esri, HERE, Garmin, Intermap, increment P Corp., GEBCO, USGS, FAO, NPS, NRCAN, GeoBase, IGN, Kadaster NL, Ordnance Survey, Esri Japan, METI, Esri China (Hong Kong), (c) OpenStreetMap contributors, and the GIS User Community

This GIS Data is for informational purposes only and is not suitable for legal, engineering, or surveying purposes. The GIS Data is provided "as is" without warranty of accuracy, timeliness, reliability, or completeness and represents only the approximate relative location of structures, rights-of-way, utilities, property boundaries and all other delineations and depictions. The user of this GIS Data acknowledges that SD1 shall not be responsible for the mis use or misinterpretation of this GIS Data and shall be free from liability for any loss, damage or inconvenience caused as a result of reliance on this GIS Data.



SD1 Infrastructure Web Map Export

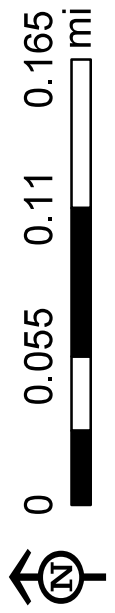

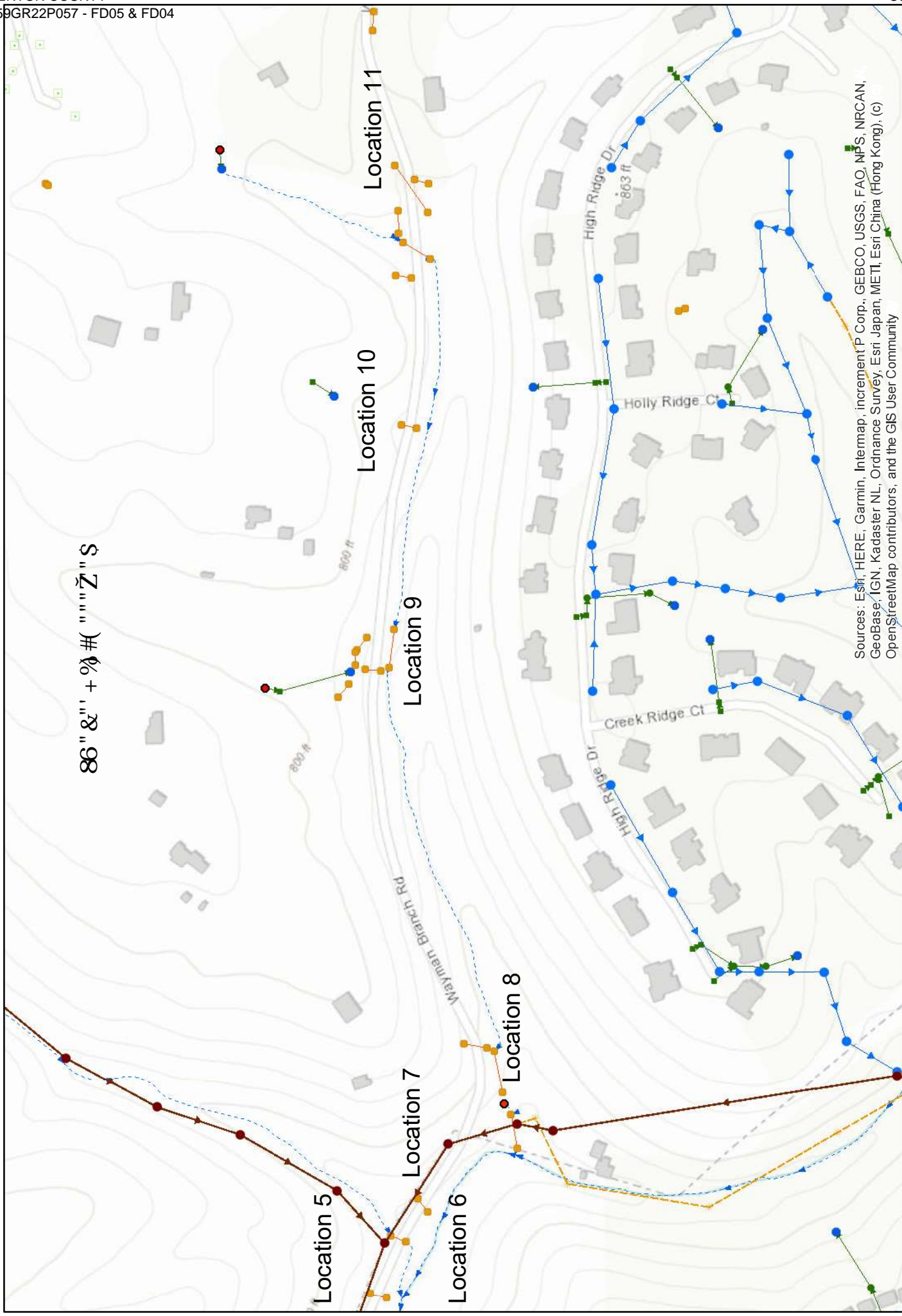

This GIS Data is for informational purposes only and is not suitable for legal, engineering, or surveying purposes. The GIS Data is provided "as is" without warranty of accuracy, timeliness, reliability, or completeness and represents only the approximate relative location of structures, rights-of-way, utilities, property boundaries and all other delineations and depictions. The user of this GIS Data acknowledges that SD1 shall not be responsible for the mis use or misinterpretation of this GIS Data and shall be free from liability for any loss, damage or inconvenience caused as a result of reliance on this GIS Data.

Sources: Esri, HERE, Garmin, Intermap, increment P Corp., GEBCO, USGS, FAO, NPS, NRCAN, GeoBase, IGN, Kadaster NL, Ordnance Survey, Esri Japan, METI, Esri China (Hong Kong), (c) OpenStreetMap contributors, and the GIS User Community

**SD1 Infrastructure
Web Map Export**

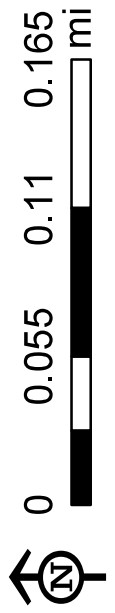

GUARDRAIL DELIVERY VERIFICATION SHEET

Contract Id: _____

Contractor: _____

Section Engineer: _____

District & County: _____

<u>DESCRIPTION</u>	<u>UNIT</u>	<u>QTY LEAVING PROJECT</u>	<u>QTY RECEIVED@BB YARD</u>
GUARDRAIL (Includes End treatments & crash cushions)	LF	_____	_____
STEEL POSTS	EACH	_____	_____
STEEL BLOCKS	EACH	_____	_____
WOOD OFFSET BLOCKS	EACH	_____	_____
BACK UP PLATES	EACH	_____	_____
CRASH CUSHION	EACH	_____	_____
NUTS, BOLTS, WASHERS	BAG/BCKT	_____	_____
DAMAGED RAIL TO MAINT. FACILITY	LF	_____	_____
DAMAGED POSTS TO MAINT. FACILITY	EACH	_____	_____

***Required Signatures before Leaving Project Site**

Printed Section Engineer's Representative _____ & Date _____

Signature Section Engineer's Representative _____ & Date _____

Printed Contractor's Representative _____ & Date _____

Signature Contractor's Representative _____ & Date _____

***Required Signatures after Arrival at Bailey Bridge Yard (All material on truck must be counted & the quantity received column completed before signatures)**

Printed Bailey Bridge Yard Representative _____ & Date _____

Signature Bailey Bridge Yard Representative _____ & Date _____

Printed Contractor's Representative _____ & Date _____

Signature Contractor's Representative _____ & Date _____

**Payment for the bid item remove guardrail will be based upon the quantities shown in the Bailey Bridge Yard received column. Payment will not be made for guardrail removal until the guardrail verification sheets are electronically submitted to the Section Engineer by the Bailey Bridge Yard Representative.

Completed Form Submitted to Section Engineer Date: _____ By: _____

PART II
SPECIFICATIONS AND STANDARD DRAWINGS

SPECIFICATIONS REFERENCE

Any reference in the plans or proposal to previous editions of the *Standard Specifications for Road and Bridge Construction* and *Standard Drawings* are superseded by *Standard Specifications for Road and Bridge Construction, Edition of 2019* and *Standard Drawings, Edition of 2020*.

SUPPLEMENTAL SPECIFICATIONS

The contractor shall use the Supplemental Specifications that are effective at the time of letting.
The Supplemental Specifications can be found at the following link:

<http://transportation.ky.gov/Construction/Pages/Kentucky-Standard-Specifications.aspx>

SPECIAL NOTE FOR PORTABLE CHANGEABLE MESSAGE SIGNS

This Special Note will apply when indicated on the plans or in the proposal.

1.0 DESCRIPTION. Furnish, install, operate, and maintain variable message signs at the locations shown on the plans or designated by the Engineer. Remove and retain possession of variable message signs when they are no longer needed on the project.

2.0 MATERIALS.

2.1 General. Use LED Variable Message Signs Class I, II, or III, as appropriate, from the Department's List of Approved Materials.

Unclassified signs may be submitted for approval by the Engineer. The Engineer may require a daytime and nighttime demonstration. The Engineer will make a final decision within 30 days after all required information is received.

2.2 Sign and Controls. All signs must:

- 1) Provide 3-line messages with each line being 8 characters long and at least 18 inches tall. Each character comprises 35 pixels.
- 2) Provide at least 40 preprogrammed messages available for use at any time. Provide for quick and easy change of the displayed message; editing of the message; and additions of new messages.
- 3) Provide a controller consisting of:
 - a) Keyboard or keypad.
 - b) Readout that mimics the actual sign display. (When LCD or LCD type readout is used, include backlighting and heating or otherwise arrange for viewing in cold temperatures.)
 - c) Non-volatile memory or suitable memory with battery backup for storing pre-programmed messages.
 - d) Logic circuitry to control the sequence of messages and flash rate.
- 4) Provide a serial interface that is capable of supporting complete remote control ability through land line and cellular telephone operation. Include communication software capable of immediately updating the message, providing complete sign status, and allowing message library queries and updates.
- 5) Allow a single person easily to raise the sign to a satisfactory height above the pavement during use, and lower the sign during travel.
- 6) Be Highway Orange on all exterior surfaces of the trailer, supports, and controller cabinet.
- 7) Provide operation in ambient temperatures from -30 to + 120 degrees Fahrenheit during snow, rain and other inclement weather.
- 8) Provide the driver board as part of a module. All modules are interchangeable, and have plug and socket arrangements for disconnection and reconnection. Printed circuit boards associated with driver boards have a conformable coating to protect against moisture.
- 9) Provide a sign case sealed against rain, snow, dust, insects, etc. The lens is UV stabilized clear plastic (polycarbonate, acrylic, or other approved material) angled to prevent glare.
- 10) Provide a flat black UV protected coating on the sign hardware, character PCB, and appropriate lens areas.
- 11) Provide a photocell control to provide automatic dimming.

- 12) Allow an on-off flashing sequence at an adjustable rate.
- 13) Provide a sight to aim the message.
- 14) Provide a LED display color of approximately 590 nm amber.
- 15) Provide a controller that is password protected.
- 16) Provide a security device that prevents unauthorized individuals from accessing the controller.
- 17) Provide the following 3-line messages preprogrammed and available for use when the sign unit begins operation:

/KEEP/RIGHT/=>=>=>/	/MIN/SPEED/**MPH/
/KEEP/LEFT/<<<</	/ICY/BRIDGE/AHEAD/ /ONE
/LOOSE/GRAVEL/AHEAD/	LANE/BRIDGE/AHEAD/
/RD WORK/NEXT/**MILES/	/ROUGH/ROAD/AHEAD/
/TWO WAY/TRAFFIC/AHEAD/	/MERGING/TRAFFIC/AHEAD/
/PAINT/CREW/AHEAD/	/NEXT/***/MILES/
/REDUCE/SPEED/**MPH/	/HEAVY/TRAFFIC/AHEAD/
/BRIDGE/WORK/***0 FT/	/SPEED/LIMIT/**MPH/
/MAX/SPEED/**MPH/	/BUMP/AHEAD/
/SURVEY/PARTY/AHEAD/	/TWO/WAY/TRAFFIC/

*Insert numerals as directed by the Engineer.
Add other messages during the project when required by the Engineer.

2.3 Power.

- 1) Design solar panels to yield 10 percent or greater additional charge than sign consumption. Provide direct wiring for operation of the sign or arrow board from an external power source to provide energy backup for 21 days without sunlight and an on-board system charger with the ability to recharge completely discharged batteries in 24 hours.

3.0 CONSTRUCTION. Furnish and operate the variable message signs as designated on the plans or by the Engineer. Ensure the bottom of the message panel is a minimum of 7 feet above the roadway in urban areas and 5 feet above in rural areas when operating. Use Class I, II, or III signs on roads with a speed limit less than 55 mph. Use Class I or II signs on roads with speed limits 55 mph or greater.

Maintain the sign in proper working order, including repair of any damage done by others, until completion of the project. When the sign becomes inoperative, immediately repair or replace the sign. Repetitive problems with the same unit will be cause for rejection and replacement.

Use only project related messages and messages directed by the Engineer, unnecessary messages lessen the impact of the sign. Ensure the message is displayed in either one or 2 phases with each phase having no more than 3 lines of text. When no message is needed, but it is necessary to know if the sign is operable, flash only a pixel.

When the sign is not needed, move it outside the clear zone or where the Engineer directs. Variable Message Signs are the property of the Contractor and shall be removed from the project when no longer needed. The Department will not assume ownership of these signs.

4.0 MEASUREMENT. The final quantity of Variable Message Sign will be

11

the actual number of individual signs acceptably furnished and operated during the project. The Department will not measure signs replaced due to damage or rejection.

5.0 PAYMENT. The Department will pay for the Variable Message Signs at the unit price each. The Department will not pay for signs replaced due to damage or rejection. Payment is full compensation for furnishing all materials, labor, equipment, and service necessary to, operate, move, repair, and maintain or replace the variable message signs. The Department will make payment for the completed and accepted quantities under the following:

<u>Code</u>	<u>Pay Item</u>	<u>Pay Unit</u>
02671	Portable Changeable Message Sign	Each

Effective June 15, 2012

2020 KENTUCKY STANDARD DRAWINGS

CURVE WIDENING AND SUPERELEVATION TRANSITIONSRGS-001-07
SUPERELEVATION FOR MULTILANE PAVEMENTRGS-002-06
MISCELLANEOUS STANDARDSRGX-001-06
APPROACHES, ENTRANCES, AND MAIL BOX TURNOUTRPM-110-07
PAVEMENT STRIPING DETAILS FOR TWO LANE TWO WAY ROADWAYSTPM-175
LANE CLOSURE TWO-LANE HIGHWAYTTC-100-05
LANE CLOSURE MULTI-LANE HIGHWAY CASE I.....TTC-115-04
LANE CLOSURE MULTI-LANE HIGHWAY CASE IITTC-120-04
SHOULDER CLOSURETTC-135-03
PAVEMENT CONDITION WARNING SIGNS.....TTD-125-06
MOBILE OPERATION FOR PAINT STRIPING CASE ITTS-100-02
MOBILE OPERATION FOR PAINT STRIPING CASE II.....TTS-105-02
INSTALLATION OF GUARDRAIL END TREATMENT TYPE 1.....RBI-004-06
STEEL BEAM GUARDRAIL (“W”-BEAM).....RBR-001-13
GUARDRAIL COMPONENTS.....RBR-005-11
GUARDRAIL END TREATMENT TYPE 1RBR-020-07
CHANNEL LINING CLASS II AND III.....RDD-040-05
CULVERT & STORM SEWER PIPE TYPES & COVER HEIGHTS.....RDI-003-05
CULVERT & STORM SEWER PIPE TYPES & COVER HEIGHTS.....RDI-004-04
CULVERT & STORM SEWER PIPE TYPES & COVER HEIGHTS.....RDI-005-04
CULVERT & STORM SEWER PIPE TYPES & COVER HEIGHTS.....RDI-006-04
CULVERT & STORM SEWER PIPE TYPES & COVER HEIGHTS.....RDI-007-04
CULVERT & STORM SEWER PIPE TYPES & COVER HEIGHTS.....RDI-008-04

PART III

EMPLOYMENT, WAGE AND RECORD REQUIREMENTS

**TRANSPORTATION CABINET
DEPARTMENT OF HIGHWAYS**

**LABOR AND WAGE REQUIREMENTS
APPLICABLE TO OTHER THAN FEDERAL-AID SYSTEM PROJECTS**

- I. Application
- II. Nondiscrimination of Employees (KRS 344)

I. APPLICATION

1. These contract provisions shall apply to all work performed on the contract by the contractor with his own organization and with the assistance of workmen under his immediate superintendence and to all work performed on the contract by piecework, station work or by subcontract. The contractor's organization shall be construed to include only workmen employed and paid directly by the contractor and equipment owned or rented by him, with or without operators.

2. The contractor shall insert in each of his subcontracts all of the stipulations contained in these Required Provisions and such other stipulations as may be required.

3. A breach of any of the stipulations contained in these Required Provisions may be grounds for termination of the contract.

3. If the contractor is in control of apprenticeship or other training or retraining, including on-the-job training programs, he shall not discriminate against an individual because of his race, color, religion, national origin, sex, disability or age forty (40) and over, in admission to, or employment in any program established to provide apprenticeship or other training.

4. The contractor will send to each labor union or representative of workers with which he has a collective bargaining agreement or other contract or understanding, a notice to be provided advising the said labor union or workers' representative of the contractor's commitments under this section, and shall post copies of the notice in conspicuous places available to employees and applicants for employment. The contractor will take such action with respect to any subcontract or purchase order as the administrating agency may direct as a means of enforcing such provisions, including sanctions for non-compliance.

Revised: January 25, 2017

II. NONDISCRIMINATION OF EMPLOYEES

**AN ACT OF THE KENTUCKY
GENERAL ASSEMBLY TO PREVENT
DISCRIMINATION IN EMPLOYMENT
KRS CHAPTER 344
EFFECTIVE JUNE 16, 1972**

The contract on this project, in accordance with KRS Chapter 344, provides that during the performance of this contract, the contractor agrees as follows:

1. The contractor shall not fail or refuse to hire, or shall not discharge any individual, or otherwise discriminate against an individual with respect to his compensation, terms, conditions, or privileges of employment, because of such individual's race, color, religion, national origin, sex, disability or age (forty and above); or limit, segregate, or classify his employees in any way which would deprive or tend to deprive an individual of employment opportunities or otherwise adversely affect his status as an employee, because of such individual's race, color, religion, national origin, sex, disability or age forty (40) and over. The contractor agrees to post in conspicuous places, available to employees and applicants for employment, notices to be provided setting forth the provisions of this nondiscrimination clause.

2. The contractor shall not print or publish or cause to be printed or published a notice or advertisement relating to employment by such an employer or membership in or any classification or referral for employment by the employment agency, indicating any preference, limitation, specification, or discrimination, based on race, color, religion, national origin, sex, or age forty (40) and over, or because the person is a qualified individual with a disability, except that such a notice or advertisement may indicate a preference, limitation, or specification based on religion, national origin, sex, or age forty (40) and over, or because the person is a qualified individual with a disability, when religion, national origin, sex, or age forty (40) and over, or because the person is a qualified individual with a disability, is a bona fide occupational qualification for employment.

EXECUTIVE BRANCH CODE OF ETHICS

In the 1992 regular legislative session, the General Assembly passed and Governor Brereton Jones signed Senate Bill 63 (codified as KRS 11A), the Executive Branch Code of Ethics, which states, in part:

KRS 11A.040 (7) provides:

No present or former public servant shall, within six (6) months following termination of his office or employment, accept employment, compensation, or other economic benefit from any person or business that contracts or does business with, or is regulated by, the state in matters in which he was directly involved during the last thirty-six (36) months of his tenure. This provision shall not prohibit an individual from returning to the same business, firm, occupation, or profession in which he was involved prior to taking office or beginning his term of employment, or for which he received, prior to his state employment, a professional degree or license, provided that, for a period of six (6) months, he personally refrains from working on any matter in which he was directly involved during the last thirty-six (36) months of his tenure in state government. This subsection shall not prohibit the performance of ministerial functions, including but not limited to filing tax returns, filing applications for permits or licenses, or filing incorporation papers, nor shall it prohibit the former officer or public servant from receiving public funds disbursed through entitlement programs.

KRS 11A.040 (9) states:

A former public servant shall not represent a person or business before a state agency in a matter in which the former public servant was directly involved during the last thirty-six (36) months of his tenure, for a period of one (1) year after the latter of:

- a) The date of leaving office or termination of employment; or
- b) The date the term of office expires to which the public servant was elected.

This law is intended to promote public confidence in the integrity of state government and to declare as public policy the idea that state employees should view their work as a public trust and not as a way to obtain private benefits.

If you have worked for the executive branch of state government within the past six months, you may be subject to the law's prohibitions. The law's applicability may be different if you hold elected office or are contemplating representation of another before a state agency.

Also, if you are affiliated with a firm which does business with the state and which employs former state executive-branch employees, you should be aware that the law may apply to them.

In case of doubt, the law permits you to request an advisory opinion from the Executive Branch Ethics Commission, 1025 Capital Center Drive, Suite 104, Frankfort, Kentucky 40601; telephone (502) 564-7954.

Revised: May 23, 2022

Kentucky Equal Employment Opportunity Act of 1978

The requirements of the Kentucky Equal Employment Opportunity Act of 1978 (KRS 45.560-45.640) shall apply to this Contract. The apparent low Bidder will be required to submit EEO forms to the Division of Construction Procurement, which will then forward to the Finance and Administration Cabinet for review and approval. No award will become effective until all forms are submitted and EEO/CC has certified compliance. The required EEO forms are as follows:

- EEO-1: Employer Information Report
- Affidavit of Intent to Comply
- Employee Data Sheet
- Subcontractor Report

These forms are available on the Finance and Administration's web page under ***Vendor Information, Standard Attachments and General Terms*** at the following address:
<https://www.eProcurement.ky.gov>.

Bidders currently certified as being in compliance by the Finance and Administration Cabinet may submit a copy of their approval letter in lieu of the referenced EEO forms.

For questions or assistance please contact the Finance and Administration Cabinet by email at **finance.contractcompliance@ky.gov** or by phone at 502-564-2874.

EMPLOYEE RIGHTS UNDER THE FAIR LABOR STANDARDS ACT

THE UNITED STATES DEPARTMENT OF LABOR WAGE AND HOUR DIVISION

FEDERAL MINIMUM WAGE

\$7.25 PER HOUR

BEGINNING JULY 24, 2009

OVERTIME PAY At least 1½ times your regular rate of pay for all hours worked over 40 in a workweek.

CHILD LABOR An employee must be at least **16** years old to work in most non-farm jobs and at least **18** to work in non-farm jobs declared hazardous by the Secretary of Labor.

Youths **14** and **15** years old may work outside school hours in various non-manufacturing, non-mining, non-hazardous jobs under the following conditions:

No more than

- **3** hours on a school day or **18** hours in a school week;
- **8** hours on a non-school day or **40** hours in a non-school week.

Also, work may not begin before **7 a.m.** or end after **7 p.m.**, except from June 1 through Labor Day, when evening hours are extended to **9 p.m.** Different rules apply in agricultural employment.

TIP CREDIT Employers of “tipped employees” must pay a cash wage of at least \$2.13 per hour if they claim a tip credit against their minimum wage obligation. If an employee’s tips combined with the employer’s cash wage of at least \$2.13 per hour do not equal the minimum hourly wage, the employer must make up the difference. Certain other conditions must also be met.

ENFORCEMENT The Department of Labor may recover back wages either administratively or through court action, for the employees that have been underpaid in violation of the law. Violations may result in civil or criminal action.

Employers may be assessed civil money penalties of up to \$1,100 for each willful or repeated violation of the minimum wage or overtime pay provisions of the law and up to \$11,000 for each employee who is the subject of a violation of the Act’s child labor provisions. In addition, a civil money penalty of up to \$50,000 may be assessed for each child labor violation that causes the death or serious injury of any minor employee, and such assessments may be doubled, up to \$100,000, when the violations are determined to be willful or repeated. The law also prohibits discriminating against or discharging workers who file a complaint or participate in any proceeding under the Act.

ADDITIONAL INFORMATION

- Certain occupations and establishments are exempt from the minimum wage and/or overtime pay provisions.
- Special provisions apply to workers in American Samoa and the Commonwealth of the Northern Mariana Islands.
- Some state laws provide greater employee protections; employers must comply with both.
- The law requires employers to display this poster where employees can readily see it.
- Employees under 20 years of age may be paid \$4.25 per hour during their first 90 consecutive calendar days of employment with an employer.
- Certain full-time students, student learners, apprentices, and workers with disabilities may be paid less than the minimum wage under special certificates issued by the Department of Labor.

For additional information:



1-866-4-USWAGE

(1-866-487-9243) TTY: 1-877-889-5627



WWW.WAGEHOUR.DOL.GOV

PART IV
INSURANCE

Refer to
Kentucky Standard Specifications for Road and Bridge Construction,
current edition

PART V
BID ITEMS

PROPOSAL BID ITEMS

222441

Page 1 of 2

Report Date 6/16/22

Section: 0001 - PAVING

LINE	BID CODE	ALT	DESCRIPTION	QUANTITY	UNIT	UNIT PRIC	FP	AMOUNT
0010	00190		LEVELING & WEDGING PG64-22	140.00	TON		\$	
0020	00356		ASPHALT MATERIAL FOR TACK	31.00	TON		\$	
0030	00388		CL3 ASPH SURF 0.38B PG64-22	4,825.00	TON		\$	
0040	02562		TEMPORARY SIGNS	990.00	SQFT		\$	
0050	02650		MAINTAIN & CONTROL TRAFFIC	1.00	LS		\$	
0060	02671		PORTABLE CHANGEABLE MESSAGE SIGN	2.00	EACH		\$	
0070	02676		MOBILIZATION FOR MILL & TEXT	1.00	LS		\$	
0080	02677		ASPHALT PAVE MILLING & TEXTURING	4,825.00	TON		\$	
0090	02775		ARROW PANEL	2.00	EACH		\$	
0100	03240		BASE FAILURE REPAIR	395.00	SQYD		\$	
0110	04793		CONDUIT-1 1/4 IN	50.00	LF		\$	
0120	04811		ELECTRICAL JUNCTION BOX TYPE B	1.00	EACH		\$	
0130	04830		LOOP WIRE	1,470.00	LF		\$	
0140	04850		CABLE-NO. 14/1 PAIR	50.00	LF		\$	
0150	04895		LOOP SAW SLOT AND FILL	610.00	LF		\$	
0160	06510		PAVE STRIPING-TEMP PAINT-4 IN	90,330.00	LF		\$	
0170	06515		PAVE STRIPING-PERM PAINT-6 IN	90,330.00	LF		\$	
0180	06565		PAVE MARKING-THERMO X-WALK-6 IN	860.00	LF		\$	
0190	06568		PAVE MARKING-THERMO STOP BAR-24IN	300.00	LF		\$	
0200	06569		PAVE MARKING-THERMO CROSS-HATCH	58.00	SQFT		\$	
0210	06574		PAVE MARKING-THERMO CURV ARROW	23.00	EACH		\$	
0220	06575		PAVE MARKING-THERMO COMB ARROW	1.00	EACH		\$	
0230	06600		REMOVE PAVEMENT MARKER TYPE V	108.00	EACH		\$	
0240	10020NS		FUEL ADJUSTMENT	7,728.00	DOLL	\$1.00	\$	\$7,728.00
0250	10030NS		ASPHALT ADJUSTMENT	19,411.00	DOLL	\$1.00	\$	\$19,411.00

Section: 0002 - DRAINAGE

LINE	BID CODE	ALT	DESCRIPTION	QUANTITY	UNIT	UNIT PRIC	FP	AMOUNT
0260	00221		CL2 ASPH BASE 0.75D PG64-22	500.00	TON		\$	
0270	00462		CULVERT PIPE-18 IN	102.00	LF		\$	
0280	00464		CULVERT PIPE-24 IN	288.00	LF		\$	
0290	00468		CULVERT PIPE-36 IN	40.00	LF		\$	
0300	01987		DELINEATOR FOR GUARDRAIL BI DIRECTIONAL WHITE	40.00	EACH		\$	
0310	02014		BARRICADE-TYPE III	10.00	EACH		\$	
0320	02220		FLOWABLE FILL	100.00	CUYD		\$	
0330	02351		GUARDRAIL-STEEL W BEAM-S FACE	1,887.50	LF		\$	
0340	02367		GUARDRAIL END TREATMENT TYPE 1	12.00	EACH		\$	
0350	02381		REMOVE GUARDRAIL	1,800.00	LF		\$	
0360	02483		CHANNEL LINING CLASS II	250.00	TON		\$	
0370	02562		TEMPORARY SIGNS	190.00	SQFT		\$	
0380	02575		DITCHING AND SHOULDERING	6,320.00	LF		\$	
0390	02610		RETAINING WALL-GABION	48.00	CUYD		\$	
0400	02650		MAINTAIN & CONTROL TRAFFIC	1.00	LS		\$	
0410	02671		PORTABLE CHANGEABLE MESSAGE SIGN	2.00	EACH		\$	

PROPOSAL BID ITEMS

222441

Page 2 of 2

Report Date 6/16/22

LINE	BID CODE	ALT	DESCRIPTION	QUANTITY	UNIT	UNIT PRIC	FP	AMOUNT
0420	02690		SAFELOADING	5.00	CUYD		\$	
0430	03271		TREE TRIMMING	4,800.00	LF		\$	
0440	08100		CONCRETE-CLASS A	2.00	CUYD		\$	

Section: 0003 - DEMOBILIZATION

LINE	BID CODE	ALT	DESCRIPTION	QUANTITY	UNIT	UNIT PRIC	FP	AMOUNT
0450	02569		DEMOBILIZATION	1.00	LS		\$	