



**CALL NO. 400**

**CONTRACT ID. 222287**

**ADAIR COUNTY**

**FED/STATE PROJECT NUMBER 001GR22P047-FD05**

**DESCRIPTION KY 55X & KY 61 IN ADAIR COUNTY**

**WORK TYPE ASPHALT RESURFACING**

**PRIMARY COMPLETION DATE 11/15/2022**

**LETTING DATE: May 26,2022**

Sealed Bids will be received electronically through the Bid Express bidding service until 10:00 AM EASTERN DAYLIGHT TIME May 26,2022. Bids will be publicly announced at 10:00 AM EASTERN DAYLIGHT TIME.

**NO PLANS ASSOCIATED WITH THIS PROJECT.**

**DEFERRED PAYMENT**

**REQUIRED BID PROPOSAL GUARANTY:** Not less than 5% of the total bid.

## TABLE OF CONTENTS

PART I	SCOPE OF WORK
	<ul style="list-style-type: none"><li>• PROJECT(S), COMPLETION DATE(S), &amp; LIQUIDATED DAMAGES</li><li>• CONTRACT NOTES</li><li>• STATE CONTRACT NOTES</li><li>• DEFERRED PAYMENT</li><li>• NATIONAL HIGHWAY</li><li>• SURFACING AREAS</li><li>• ASPHALT MIXTURE</li><li>• INCIDENTAL SURFACING</li><li>• FUEL AND ASPHALT PAY ADJUSTMENT</li><li>• COMPACTION OPTION A</li><li>• COMPACTION OPTION B</li><li>• WASTE AND BORROW SITES</li><li>• ASPHALT MIX PAVEMENT WEDGE MONOLITHIC OPERATION</li><li>• EDGE KEY (BY LINEAR FEET)</li><li>• ASPHALT MILLING AND TEXTURING</li><li>• ASPHALT MILLING AND TEXTURING</li><li>• BASE FAILURE REPAIR</li><li>• TYPICAL SECTION DIMENSIONS</li><li>• TRAFFIC CONTROL PLAN 4 LANE</li><li>• DURABLE PAVEMENT EDGE DETAILS</li><li>• TRAFFIC SIGNAL LOOP DETECTORS</li><li>• SKETCH MAP(S)</li><li>• MATERIAL SUMMARY</li><li>• SUMMARY SHEET(S)</li><li>• TYPICAL SECTION(S)</li><li>• DETAIL SHEET(S)</li><li>• BRIDGE DETAIL FOR PAVING PROJECT</li></ul>
PART II	SPECIFICATIONS AND STANDARD DRAWINGS
	<ul style="list-style-type: none"><li>• SPECIFICATIONS REFERENCE</li><li>• SUPPLEMENTAL SPECIFICATION</li><li>• [SN-1I] PORTABLE CHANGEABLE SIGNS</li><li>• 2020 STANDARD DRAWINGS THAT APPLY</li></ul>
PART III	EMPLOYMENT, WAGE AND RECORD REQUIREMENTS
	<ul style="list-style-type: none"><li>• LABOR AND WAGE REQUIREMENTS</li><li>• EXECUTIVE BRANCH CODE OF ETHICS</li><li>• KENTUCKY EQUAL EMPLOYMENT OPPORTUNITY ACT OF 1978 LOCALITY / STATE</li><li>• PROJECT WAGE RATES / STATE FUNDED</li></ul>
PART IV	INSURANCE
PART V	BID ITEMS

**PART I**  
**SCOPE OF WORK**

## ADMINISTRATIVE DISTRICT - 08

**CONTRACT ID - 222287**

**001GR22P047-FD05**

**COUNTY - ADAIR**

**PCN - MP00100612301**

**FD05 001 0061 017-020**

COLUMBIA - GREENSBURG ROAD (KY 61) (MP 17.193) FROM KY 768 EXTENDING NORTH TO GREEN COUNTY LINE (MP 19.745), A DISTANCE OF 02.55 MILES.ASPHALT RESURFACING

GEOGRAPHIC COORDINATES LATITUDE 37:08:15.00 LONGITUDE 85:23:50.00

ADT 1,297

**PCN - MP00100612303**

**FD05 001 0061 010-013**

BURKESVILLE - COLUMBIA ROAD (KY 61) (MP 10.500) 530 FEET NORTH OF GOLDENROD LANE EXTENDING TO KY 55 (MP 12.213), A DISTANCE OF 01.71 MILES.ASPHALT RESURFACING

GEOGRAPHIC COORDINATES LATITUDE 37:04:46.00 LONGITUDE 85:20:05.00

ADT 7,817

**PCN - MP001055X2301**

**FD05 001 055X 000-001**

JAMESTOWN STREET (KY 55X) (MP 0.000) FROM KY 6177/KY 55 EXTENDING NORTH TO CUMBERLAND PARKWAY OVERPASS (MP 0.391), A DISTANCE OF 0.39 MILES.ASPHALT RESURFACING

GEOGRAPHIC COORDINATES LATITUDE 37:05:10.00 LONGITUDE 85:18:50.00

ADT 5,971

**COMPLETION DATE(S):**

COMPLETED BY 11/15/2022

APPLIES TO ENTIRE CONTRACT

## **CONTRACT NOTES**

### **PROPOSAL ADDENDA**

All addenda to this proposal must be applied when calculating bid and certified in the bid packet submitted to the Kentucky Department of Highways. Failure to use the correct and most recent addenda may result in the bid being rejected.

### **BID SUBMITTAL**

Bidder must use the Department's electronic bidding software. The Bidder must download the bid file located on the Bid Express website ([www.bidx.com](http://www.bidx.com)) to prepare a bid packet for submission to the Department. The bidder must submit electronically using Bid Express.

### **JOINT VENTURE BIDDING**

Joint venture bidding is permissible. All companies in the joint venture must be prequalified in one of the work types in the Qualifications for Bidders for the project. The bidders must get a vendor ID for the joint venture from the Division of Construction Procurement and register the joint venture as a bidder on the project. Also, the joint venture must obtain a digital ID from Bid Express to submit a bid. A joint bid bond of 5% may be submitted for both companies or each company may submit a separate bond of 5%.

### **UNDERGROUND FACILITY DAMAGE PROTECTION**

The contractor shall make every effort to protect underground facilities from damage as prescribed in the Underground Facility Damage Protection Act of 1994, Kentucky Revised Statute KRS 367.4901 to 367.4917. It is the contractor's responsibility to determine and take steps necessary to be in compliance with federal and state damage prevention directives. When prescribed in said directives, the contractor shall submit Excavation Locate Requests to the Kentucky Contact Center (KY811) via web ticket entry. The submission of this request does not relieve the contractor from the responsibility of contacting non-member facility owners, whom shall be contacted through their individual Protection Notification Center. Non-compliance with these directives can result in the enforcement of penalties.

### **REGISTRATION WITH THE SECRETARY OF STATE BY A FOREIGN ENTITY**

Pursuant to KRS 176.085(1)(b), an agency, department, office, or political subdivision of the Commonwealth of Kentucky shall not award a state contract to a person that is a foreign entity required by [KRS 14A.9-010](#) to obtain a certificate of authority to transact business in the Commonwealth ("certificate") from the Secretary of State under [KRS 14A.9-030](#) unless the person produces the certificate within fourteen (14) days of the bid or proposal opening. If the foreign entity is not required to obtain a certificate as provided in [KRS 14A.9-010](#), the foreign entity should identify the applicable exception. Foreign entity is defined within [KRS 14A.1-070](#).

**For all foreign entities required to obtain a certificate of authority to transact business in the Commonwealth, if a copy of the certificate is not received by the contracting agency within the time frame identified above, the foreign entity's solicitation response shall be deemed non-responsive or the awarded contract shall be cancelled.**

Businesses can register with the Secretary of State at <https://secure.kentucky.gov/sos/ftbr/welcome.aspx>.

### **SPECIAL NOTE FOR PROJECT QUESTIONS DURING ADVERTISEMENT**

Questions about projects during the advertisement should be submitted in writing to the Division of Construction Procurement. This may be done by fax (502) 564-7299 or email to [kytc.projectquestions@ky.gov](mailto:kytc.projectquestions@ky.gov). The Department will attempt to answer all submitted questions. The Department reserves the right not to answer if the question is not pertinent or does not aid in clarifying the project intent.

The deadline for posting answers will be 3:00 pm Eastern Daylight Time, the day preceding the Letting. Questions may be submitted until this deadline with the understanding that the later a question is submitted, the less likely an answer will be able to be provided.

The questions and answers will be posted for each Letting under the heading "Questions & Answers" on the Construction Procurement website ([www.transportation.ky.gov/contract](http://www.transportation.ky.gov/contract)). The answers provided shall be considered part of this Special Note and, in case of a discrepancy, will govern over all other bidding documents.

### **HARDWOOD REMOVAL RESTRICTIONS**

The US Department of Agriculture has imposed a quarantine in Kentucky and several surrounding states, to prevent the spread of an invasive insect, the emerald ash borer. Hardwood cut in conjunction with the project may not be removed from the state. Chipping or burning on site is the preferred method of disposal.

### **INSTRUCTIONS FOR EXCESS MATERIAL SITES AND BORROW SITES**

Identification of excess material sites and borrow sites shall be the responsibility of the Contractor. The Contractor shall be responsible for compliance with all applicable state and federal laws and may wish to consult with the US Fish and Wildlife Service to seek protection under Section 10 of the Endangered Species Act for these activities.

### **ACCESS TO RECORDS**

The contractor, as defined in KRS 45A.030 (9) agrees that the contracting agency, the Finance and Administration Cabinet, the Auditor of Public Accounts, and the Legislative Research Commission, or their duly authorized representatives, shall have access to any books, documents, papers, records, or other evidence, which are directly pertinent to this contract for the purpose of financial audit or program review. Records and other prequalification information confidentially

disclosed as part of the bid process shall not be deemed as directly pertinent to the contract and shall be exempt from disclosure as provided in KRS 61.878(1)(c). The contractor also recognizes that any books, documents, papers, records, or other evidence, received during a financial audit or program review shall be subject to the Kentucky Open Records Act, KRS 61.870 to 61.884.

In the event of a dispute between the contractor and the contracting agency, Attorney General, or the Auditor of Public Accounts over documents that are eligible for production and review, the Finance and Administration Cabinet shall review the dispute and issue a determination, in accordance with Secretary's Order 11-004.

April 30, 2018

## **SPECIAL NOTE FOR RECIPROCAL PREFERENCE**

### **RECIPROCAL PREFERENCE TO BE GIVEN BY PUBLIC AGENCIES TO RESIDENT BIDDERS**

By reference, KRS 45A.490 to 45A.494 are incorporated herein and in compliance regarding the bidders residency. Bidders who want to claim resident bidder status should complete the Affidavit for Claiming Resident Bidder Status along with their bid in the electronic bidding software. Submittal of the Affidavit should be done along the bid in Bid Express.

April 30, 2018



### **DEFERRED PAYMENT**

The successful bidder on this project may request a work order with an effective date prior to June 15, 2022. The successful bidder must make the request in writing to the Department. The Department will issue a work order at the request of the contractor with the distinct understanding that payment for any Work Performed Estimates may be delayed until July 15, 2022. Unless the successful bidder requests an earlier work order date, the Department will issue a work order on June 15, 2022 for this project.

### **(FD05 001 055X 000-001)**

#### **NATIONAL HIGHWAY**

Be advised this project is on the NATIONAL HIGHWAY SYSTEM.

### **FD05 001 055X 000-001**

#### **SURFACING AREAS**

The Department estimates the mainline surfacing width to be varied 21-54 feet.

The Department estimates the total mainline area to be surfaced to be 10,667 square yards.

The Department estimates the shoulder width to be varied 0-10 feet on each side.

The Department estimates the total shoulder area to be surfaced to be 520 square yards

FD05 001 0061 010-013

#### **SURFACING AREAS**

The Department estimates the mainline surfacing width to be varied 38-60 feet.

The Department estimates the total mainline area to be surfaced to be 66,170 square yards.

The Department estimates the shoulder width to be varied 0-9 feet on each side.

The Department estimates the total shoulder area to be surfaced to be 18,090 square yards.

FD05 001 0061 017-020

#### **SURFACING AREAS**

The Department estimates the mainline surfacing width to be 22 feet.

The Department estimates the total mainline area to be surfaced to be 39,232 square yards.

The Department estimates the shoulder width to be 1 foot on each side.

The Department estimates the total shoulder area to be surfaced to be 2,994 square yards.

### **ASPHALT MIXTURE**

Unless otherwise noted, the Department estimates the rate of application for all asphalt mixtures to be 110 lbs/sy per inch of depth.

### **INCIDENTAL SURFACING**

The Department has included in the quantities of asphalt mixtures established in the proposal estimated quantities required for resurfacing or surfacing mailbox turnouts, farm field entrances, residential and commercial entrances, curve widening, ramp gores and tapers, and road and street approaches, as applicable. Pave these areas to the limits as shown on Standard Drawing RPM-110-06 or as directed by the Engineer. In the event signal detectors are present in the intersecting streets or roads, pave the crossroads to the right of way limit or back of the signal detector, whichever is the farthest back of the mainline. Surface or resurface these areas as directed by the Engineer. The Department will not measure placing and compacting for separate payment but shall be incidental to the Contract unit price for the asphalt mixtures.

### **FUEL AND ASPHALT PAY ADJUSTMENT**

The Department has included the Contract items Asphalt Adjustment and Fuel Adjustment for possible future payments at an established Contract unit price of \$1.00. The Department will calculate actual adjustment quantities after work is completed. If

existing Contract amount is insufficient to pay all items on the contract with the adjustments, the Department will establish additional monies with a change order.

**OPTION A (FD05 001 0061 010-013)**

Be advised that the Department will accept compaction of asphalt mixtures furnished for driving lanes and ramps, at 1 inch (25mm) or greater, on this project according to OPTION A in accordance with Section 402 and Section 403 of the current Standard Specifications. The Department will require joint cores as described in Section 402.03.02 for surface mixtures only. The Department will accept compaction of all other asphalt mixtures according to OPTION B.

**OPTION B (FD05 001 055X 000-001 & FD05 001 0061 017-020)**

Be advised that the Department will control and accept compaction of asphalt mixtures furnished on this project under OPTION B in accordance with Sections 402 and 403.

## **SPECIAL PROVISION FOR WASTE AND BORROW SITES**

Obtain U.S. Army Corps of Engineer's approval before utilizing a waste or borrow site that involves "Waters of the United States". The Corps of Engineers defines "Waters of the United States" as perennial or intermittent streams, ponds or wetlands. The Corps of Engineers also considers ephemeral streams, typically dry except during rainfall but having a defined drainage channel, to be jurisdictional waters. Direct questions concerning any potential impacts to "Waters of the United States" to the attention of the appropriate District Office for the Corps of Engineers for a determination prior to disturbance. Be responsible for any fees associated with obtaining approval for waste and borrow sites from the U.S. Army Corps of Engineer or other appropriate regulatory agencies.

1-296 Waste & Borrow Sites  
01/02/2012

## SPECIAL NOTE FOR PAVEMENT WEDGE AND SHOULDER MONOLITHIC OPERATION

**1.0 MATERIALS.** Provide an Asphalt Surface Mixture conforming to Section 403 of the Standard Specifications, as applicable to the project, for the pavement wedge.

**2.0 CONSTRUCTION.** Place the specified Asphalt Surface Mixture on shoulders monolithically with the driving lane. Prime the existing shoulder with tack material as the Engineer directs before placing the wedge. Construct according to Section 403.03 of the Standard Specifications.

Equip the paver with a modified screed that extends the full width of the wedge being placed and is tapered to produce a wedge. Obtain the Engineer's approval of the modified screed before placing shoulder wedge monolithically with the driving lane.

The wedge may vary in thickness at the edge of the milled area in the shoulder. If the area to receive the shoulder wedge is milled prior to placement, during rolling operations pinch the outside edge of the new inlay wedge to match the existing shoulder elevation not being resurfaced. Unless required otherwise by the Contract, construct rolled or sawed rumble strips according to Section 403.03.08, as applicable.

The following sketch is primarily for the computation of quantities; however, the wedge will result in a similar cross-section where sufficient width exists. Do not construct a shoulder for placing the wedge unless specified elsewhere in the Contract.

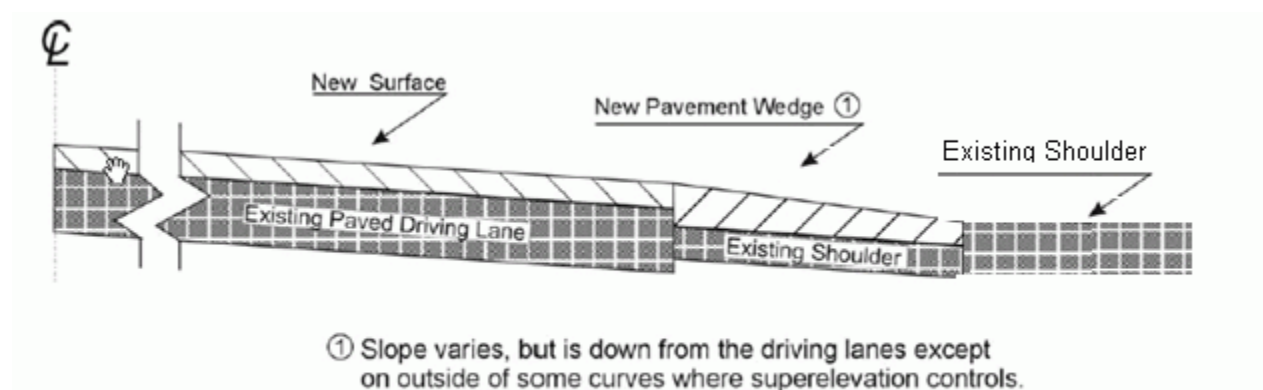

**3.0 MEASUREMENT.** The Department will measure Asphalt Surface Mixture placed as the pavement wedge according to Section 403.

**4.0 PAYMENT.** The Department will make payment for the completed and accepted quantities of Asphalt Surface Mixtures on pavement wedges according to Section 403.

**SPECIAL NOTE FOR EDGE KEY**  
(FD05 001 0061 017-020)

Construct Edge Keys at the beginning of project, end of project, at railroad crossings, and at intersections with ramps, as applicable. Unless specified in the Contract or directed by the Engineer, do not construct edge keys at intersecting streets, roads, alleys, or entrances. Cut out the existing asphalt surface to the required depth and width shown on the drawing and heel the new surface into the existing surface. The Department will measure the Edge Key at the joint as the width of the pavement perpendicular to the centerline in linear feet. The Department will pay for this work at the Contract unit price per linear foot, which shall be full compensation for all labor, materials, equipment, and incidentals for removal and disposal of the existing asphalt surface required to construct the edge key.

**EDGE KEY**

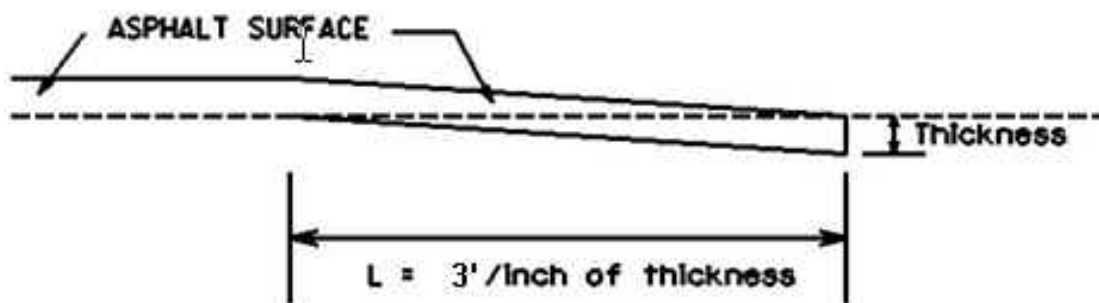

**Thickness = 1.0 Inches**

**L = 3 LF**

**L = Length of Edge Key**

1-3310 Edge Key by LF  
01/02/2012

**SPECIAL NOTE FOR  
ASPHALT MILLING AND TEXTURING**

Begin paving operations within **two weeks** of commencement of the milling operation. Continue paving operations continuously until completed. If paving operations are not begun within this time period, the Department will assess liquidated damages at the rate prescribed by Section 108.09 until such time as paving operations are begun.

Take possession of the millings and recycle the millings or dispose of the millings off the Right-of-Way at sites obtained by the Contractor at no additional cost to the Department.

1-3505 2 weeks Contractor keeps millings  
01/2/2012

**SPECIAL NOTE FOR  
ASPHALT MILLING AND TEXTURING**

Begin paving operations within **2 weeks** of commencement of the milling operation. Continue paving operations continuously until completed. If paving operations are not begun within this time period, the Department will assess liquidated damages at the rate prescribed by Section 108.09 until such time as paving operations are begun.

Contrary to Section 408, the Department will retain possession of the material obtained from the milling operations. Deliver this material to the State Maintenance facility in ADAIR County.

**NOTICE TO CONTRACTOR: The Department considers transfer of millings to the state maintenance facility to be a part of the construction project, therefore truck operators are subject to receiving prevailing wages.**

1-3515 2 weeks State keeps millings  
01/2/2012

## SPECIAL NOTE FOR BASE FAILURE REPAIR

Repair locations listed on the summary are approximate only. The Engineer will determine actual repair locations and dimensions at the time of construction. Prior to overall milling and/or leveling and wedging, excavate the designated base failure areas by milling to a depth [redacted] inches below the existing asphalt pavement surface level. Dispose of the excavated materials at waste sites off the Right-of-Way obtained by the Contractor at no additional cost to the Department. See Special Note for Waste and Borrow.

Backfill the excavated areas with Class [redacted] Asphalt Base 1.00D PG [redacted]-22. Compact the asphalt base to the compaction required in Section 403.03.10. Seal the asphalt base with leveling and wedging. Perform all base failure repairs in such a manner that removal and replacement are completed on the same day. Do this work as one of the Contractor's first operations in order to allow further compaction by traffic. Do not mill or place new asphalt surface over repaired base failure areas until a minimum of 7 calendar days have elapsed after placement of the asphalt base. After a minimum of 7 calendar days and when the Engineer determines the base failure repair areas have sufficiently stabilized, begin milling and/or resurfacing operations. Prior to milling and/or constructing the new asphalt surface, level and wedge any settlement of the repair areas.

The bidder must draw conclusions as to the conditions encountered. The Department does not give any guarantee as to the accuracy of the data and will not consider any claim for additional compensation if the materials encountered that are not in accord with the classification shown.

Accept payment at the Contract unit prices per ton for Asphalt Milling and Texturing, Asphalt Base, and Leveling and Wedging as full compensation for all labor, materials, equipment, and incidentals for removing pavement and disposing of the materials, furnishing and placing asphalt base, leveling and wedging, and all other items necessary to complete the work according to these notes to the satisfaction of the Engineer.



### **SPECIAL NOTE FOR TYPICAL SECTION DIMENSIONS**

Consider the dimensions shown on the typical sections for pavement and shoulder widths and thickness' to be nominal or typical dimensions. The Engineer may direct or approve varying the actual dimensions to be constructed to fit existing conditions. Do not widen existing pavement or shoulders unless specified elsewhere in this proposal or directed by the engineer.

1-3725 Typical Section Dimensions  
01/02/2012

## **TRAFFIC CONTROL PLAN**

---

### **TRAFFIC CONTROL GENERAL**

Except as provided herein, maintain and control traffic in accordance with the Standard and Supplemental Specifications and the Standard and Sepia Drawings, current editions. Except for the roadway and traffic control bid items listed, all items of work necessary to maintain and control traffic will be paid at the lump sum bid price to "Maintain and Control Traffic".

Contrary to Section 106.01, furnish new, or used in like new condition, traffic control devices at the beginning of the work and maintain in like new condition until completion of the work.

### **PROJECT PHASING & CONSTRUCTION PROCEDURES**

The Engineer may specify additional days and hours when lane closures will not be allowed.

At locations with three or more lanes, maintain one lane of traffic in each direction at all times during construction. At locations with two lanes, maintain alternating one way traffic during construction. Provide a minimum clear lane width of 10 feet for both KY 55X and KY 61, MP 17-20. Provide a minimum clear lane width of 11 feet for KY 61 MP 10-13; however, provide for passage of vehicles of up to 16 feet in width. If traffic should be stopped due to construction operations, and a school bus on an official run arrives on the scene, make provisions for the passage of the bus as quickly as possible.

### **LANE CLOSURES**

Do not leave lane closures in place during non-working hours.

### **SIGNS**

Sign posts and splices shall be compliant with NCHRP 350 or MASH. Manufacturer's documentation validating this compliance shall be provided to the Engineer prior to installation. Signs, including any splices, shall be installed according to manufacturer's specifications and installation recommendations. Contrary to section 112.04.02, only long-term signs (signs intended to be continuously in place for more than 3 days) will be measured for payment. Short-term signs (signs intended to be left in place for 3 days or less) will not be measured for payment but will be incidental to Maintain and Control Traffic.

Traffic Control Plan  
Page 2 of 12

### **CHANGEABLE MESSAGE SIGNS**

Provide changeable message signs in advance of and within the project at locations determined by the Engineer. If work is in progress concurrently in both directions or if more than one lane closure is in place in the same direction of travel, provide additional changeable message signs as directed by the Engineer. Place changeable message signs one mile in advance of the anticipated queue at each lane closure. As the actual queue lengthens and/or shortens, relocate or provide additional changeable message signs so that traffic has warning of slowed or stopped traffic at least one mile but not more than two miles before reaching the end of the actual queue. The Engineer may vary the designated locations as the work progresses. The Engineer will determine the messages to be displayed. In the event of damage or mechanical/electrical failure, repair or replace the Changeable Message Sign within 24 hours. The Department will measure for payment the maximum number of Changeable Message Signs in concurrent use at the same time on a single day on all sections of the contract. The Department will measure individual Changeable Message Signs only once for payment, regardless of how many times they are set, reset, removed, and relocated during the duration of the project. The Department will not measure replacements for damaged Changeable Message Signs or for signs the Engineer directs be replaced due to poor condition or readability. Retain possession of the Changeable Message Signs upon completion of the work.

### **ARROW PANELS**

Use arrow panels as shown on the Standard Drawings or as directed by the Engineer. The Department will measure for payment the maximum number of arrow panels in concurrent use at the same time on a single day on all sections of the contract. The Department will measure for payment the maximum number of Arrow Panels in concurrent use at the same time on a single day on all sections of the contract. The Department will measure individual Arrow Panels only once for payment, regardless of how many times they are set, reset, removed, and relocated during the duration of the project. The Department will not measure replacements for damaged Arrow Panels or for panels signs the Engineer directs be replaced due to poor condition or readability for payment. Retain possession of the Arrow Panels upon completion of the work.

### **TEMPORARY ENTRANCES**

The Engineer will not require the Contractor to provide continuous access to farms, single family, duplex, or triplex residential properties during working hours; however, provide reasonable egress and ingress to each such property when actual operations are not in progress at that location. Limit the time during which a farm or residential entrance is blocked to the minimum length of time required for actual operations, not extended for the Contractor's convenience, and in no case exceeding six (6) hours. Notify all residents twenty-four hours in advance of any driveway or

Traffic Control Plan  
Page 3 of 12

entrance closings and make any accommodations necessary to meet the access needs of disabled residents.

Traffic Control Plan  
Page 4 of 12

Except as allowed by the Phasing as specified above, maintain direct access to all side streets and roads, schools, churches, commercial properties and apartments or apartment complexes of four or more units at all times.

The Department will measure asphalt materials required to construct and maintain any temporary entrances which may be necessary to provide temporary access; however, the Department will not measure aggregates, excavation, and/or embankment, but shall be incidental to Maintain and Control Traffic. The Engineer will determine the type of surfacing material, asphalt or aggregate, to be used at each entrance.

### **TRAFFIC SIGNAL LOOPS**

Install traffic signal loops according to the Special Notes for Traffic Signal Loop Replacement. Coordinate the placement of the loops with the Engineer.

### **THERMOPLASTIC INTERSECTION MARKINGS**

Consider the locations listed on the summary as approximate only. Prior to milling and/or resurfacing, locate and document the locations of the existing markings. After resurfacing, replace the markings at their approximate existing locations or as directed by Engineer. Place markings not existing prior to resurfacing as directed by the Engineer.

### **BARRICADES**

The Department will not measure barricades used in lieu of barrels and cones for channelization or delineation, but shall be incidental to Maintain and Control Traffic according to Section 112.04.01.

The Department will measure barricades used to protect pavement removal areas in individual units. Each. The Department will measure for payment the maximum number of barricades in concurrent use at the same time on a single day on all sections of the contract. The Department will measure individual barricades only once for payment, regardless of how many times they are set, reset, removed, and relocated during the duration of the project. The Department will not measure replacements for damaged barricades the Engineer directs to be replaced due to poor condition or reflectivity. Retain possession of the Barricades upon completion of the work.

Traffic Control Plan  
Page 5 of 12

## PAVEMENT MARKINGS

If there is to be a deviation from the existing striping plan, the Engineer will furnish the Contractor a striping plan prior to placement of the final surface course. Install Temporary Striping according to Section 112 with the following exceptions:

1. Include edge lines in Temporary Striping; and
2. Place Temporary or Permanent Striping before opening a lane to traffic; and
3. If the Contractor's operations or phasing requires temporary markings that must subsequently be removed from the final surface course, use an approved removable lane tape; however, the Department will not measure removable lane tape for separate payment, but will measure and pay for removable lane tape as temporary striping.

## PAVEMENT EDGE DROP-OFFS

Do not allow a pavement edge between opposing directions of traffic or lanes that traffic is expected to cross in a lane change situation with an elevation difference greater than 1½". Place Warning signs (MUTCD W8-11 or W8-9A) in advance of and at 1500' intervals throughout the drop-off area. Dual post the signs on both sides of the traveled way. Wedge all transverse transitions between resurfaced and unresurfaced areas which traffic may cross with asphalt mixture for leveling and wedging. Remove the wedges prior to placement of the final surface course.

Protect pavement edges that traffic is not expected to cross, except accidentally, as follows:

Less than 2" - No protection required.

2" to 4" - Place plastic drums, vertical panels, or barricades every 50 feet. During daylight working hours only, the Engineer will allow the Contractor to use cones in lieu of plastic drums, panels, and barricades. Wedge the drop-off with DGA or asphalt mixture for leveling and wedging with a 1:1 or flatter slope in daylight hours, or 3:1 or flatter slope during nighttime hours, when work is not active in the drop-off area.

Greater than 4" - Protect drop-offs greater than 4 inches within 10 feet of traffic by placing drums, vertical panels, or barricades every 25 feet. The Engineer will not allow the use of cones in lieu of drums, vertical panels, or barricades for drop-offs greater than 4". Place Type III Barricades directly in front of the drop-off facing on coming traffic in both directions of travel. Provide warning signs as shown on the Standard Drawings or as directed by the Engineer

Pedestrians & Bicycles - Protect pedestrian and bicycle traffic as directed by the

Traffic Control Plan  
Page 6 of 12

engineer.

## USE AND PLACEMENT OF CHANGEABLE MESSAGE SIGNS

The following policy is based upon current Changeable Message Signs (CMS) standards and practice from many sources, including the Federal Highway Administration (FHWA), other State Departments of Transportation, and Traffic Safety Associations. It is understood that each CMS installation or use requires individual consideration due to the specific location or purpose. However, there will be elements that are constant in nearly all applications. Accordingly these recommended guidelines bring a level of uniformity, while still being open to regional experience and engineering judgment.

### **Application**

The primary purpose of CMS is to advise the driver of unexpected traffic and routing situations. Examples of applications where CMS can be effective include:

- Closures (road, lane, bridge, ramp, shoulder, interstate)
- Changes in alignment or surface conditions
- Significant delays, congestion
- Construction/maintenance activities (delays, future activities)
- Detours/alternative routes
- Special events with traffic and safety implications
- Crash/incidents
- Vehicle restrictions (width, height, weight, flammable)
- Advance notice of new traffic control devices
- Real-time traffic conditions (must be kept up to date)
- Weather /driving conditions, environmental conditions, Roadway Weather Information Systems
- Emergency Situations
- Referral to Highway Advisory Radio (if available)
- Messages as approved by the County Engineer's Office

### **CMS should not be used for:**

- Replacement of static signs (e.g. road work ahead), regulatory signage (e.g. speed limits), pavement markings, standard traffic control devices, conventional warning or guide signs.
- Replacement of lighted arrow board
- Advertising (Don't advertise the event unless clarifying "action" to be taken by driver – e.g. Speedway traffic next exit)
- Generic messages
- Test messages (portable signs only)
- Describe recurrent congestion (e.g. rush hour)
- Public service announcements (not traffic related)



Traffic Control Plan  
Page 8 of 12

### **Messages**

Basic principles that are important to providing proper messages and insuring the proper operation of a CMS are:

- Visible for at least ½ mile under ideal daytime and nighttime conditions
- Legible from all lanes a minimum of 650 feet
- Entire message readable twice while traveling at the posted speed
- Nor more than two message panels should be used (three panels may be used on roadways where vehicles are traveling less than 45 mph). A panel is the message that fits on the face of the sign without flipping or scrolling.
- Each panel should convey a single thought; short and concise
- Do not use two unrelated panels on a sign
- Do not use the sign for two unrelated messages
- Should not scroll text horizontally or vertically
- Should not contain both the words left and right
- Use standardized abbreviations and messages
- Should be accurate and timely
- Avoid filler/unnecessary words and periods (hazardous, a, an, the)
- Avoid use of speed limits
- Use words (not numbers) for dates

### **Placement**

Placement of the CMS is important to insure that the signs is visible to the driver and provides ample time to take any necessary action. Some of the following principles may only be applicable to controlled access roadways. The basic principles of placement for a CMS are:

- When 2 signs are needed, place on same side of roadway and at least 1,000 feet apart
- Place behind semi-rigid/rigid protection (guardrail, barrier) or outside of the clear zone
- Place 1,000 feet in advance of work zone; at least one mile ahead of decision point
- Normally place on right side of roadway; but should be placed closest to the affected lane so that either side is acceptable
- Signs should not be dual mounted (one on each side of roadway facing same direction)
- Point trailer hitch downstream
- Secure to immovable object to prevent thief (if necessary)
- Do not place in sags or just beyond crest
- Check for reflection of sun to prevent the blinding of motorist
- Should be turned ~3 degrees outward from perpendicular to the edge of pavement
- Bottom of sign should be 7 feet above the elevation of edge of roadway
- Should be removed when not in use
-

Traffic Control Plan  
Page 9 of 12

**Standard Abbreviations**

The following is a list of standard abbreviations to be used on CMS.

<b><u>Word</u></b>	<b><u>Abbrev.</u></b>	<b><u>Example</u></b>
Access	ACCS	ACCIDENT AHEAD/USE ACCS RD NEXT RIGHT
Alternate	ALT	ACCIDENT AHEAD/USE ALT RTE NEXT RIGHT
Avenue	AVE	FIFTH AVE CLOSED/DETOUR NEXT LEFT
Blocked	BLKD	FIFTH AVE BLKD/MERGE LEFT
Boulevard	BLVD	MAIN BLVD CLOSED/USE ALT RTE
Bridge	BRDG	SMITH BRDG CLOSED/USE ALT RTE
Cardinal Directions	N, S, E, W	N I75 CLOSED/ DETOUR EXIT 30
Center	CNTR	CNTR LANE CLOSED/MERGE LEFT
Commercial	COMM	OVRSZ COMM VEH/USE I275
Condition	COND	ICY COND POSSIBLE
Congested	CONG	HVY CONG NEXT 3 MI
Construction	CONST	CONST WORK AHEAD/EXPECT DELAYS
Downtown	DWNTN	DWNTN TRAF USE EX 40
Eastbound	E-BND	E-BND I64 CLOSED/DETOUR EXIT 20
Emergency	EMER	EMER VEH AHEAD/PREPARE TO STOP
Entrance, Enter	EX, EXT	DWNTN TRAF USE EX 40
Expressway	EXPWY	WTRSN EXPWY CLOSED/DETOUR EXIT 10
Freeway	FRWY, FWY	GN SYNDR FWY CLOSED/DETOUR EXIT 15
Hazardous Materials	HAZMAT	HAZMAT IN ROADWAY/ALL TRAF EXIT 25
Highway	HWY	ACCIDENT ON AA HWY/EXPECT DELAYS
Hour	HR	ACCIDENT ON AA HWY/2 HR DELAY
Information	INFO	TRAF INFO TUNE TO 1240 AM
Interstate	I	E-BND I64 CLOSED/DETOUR EXIT 20
Lane	LN	LN CLOSED/MERGE LEFT
Left	LFT	LANE CLOSED/MERGE LFT
Local	LOC	LOC TRAF USE ALT RTE
Maintenance	MAINT	MAINT WRK ON BRDG/SLOW
Major	MAJ	MAJ DELWAYS I75/USE ALT RTE

Traffic Control Plan  
Page 10 of 12

Mile	MI	ACCIDENT 3 MI AHEAD/ USE ALT RTE
Minor Minutes	MNR MIN	ACCIDENT 3 MI MNR DELAY ACCIDENT 3 MI/30 MIN DELAY
Northbound	N-BND	N-BND I75 CLOSED/ DETOUR EXIT 50
Oversized	OVRSZ	OVRSZ COMM VEH/USE I275 NEXT RIGHT
Parking Parkway	PKING PKWY	EVENT PKING NEXT RGT CUM PKWAY TRAF/DETOUR EXIT 60
Prepare Right Road Roadwork	PREP RGT RD RDWK	ACCIDENT 3 MIL/PREP TO STOP EVENT PKING NEXT RGT HAZMAT IN RD/ALL TRAF EXIT 25 RDWK NEXT 4 MI/POSSIBLE DELAYS
Route Shoulder Slippery Southbound	RTE SHLDR SLIP S-BND	MAJ DELAYS I75/USE ALT RTE SHLDR CLOSED NEXT 5 MI SLIP COND POSSIBLE/ SLOW SPD S-BND I75 CLOSED/DETOUR EXIT 50
Speed Street Traffic	SPD ST TRAF	SLIP COND POSSIBLE/ SLOW SPD MAIN ST CLOSED/USE ALT RTE CUM PKWAY TRAF/DETOUR EXIT 60
Vehicle	VEH	OVRSZ COMM VEH/USE I275 NEXT RIGHT
Westbound	W-BND	W-BND I64 CLOSED/DETOUR EXIT 50
Work	WRK	CONST WRK 2MI/POSSIBLE DELAYS

Certain abbreviations are prone to inviting confusion because another word is abbreviated or could be abbreviated in the same way. DO NO USE THESE ABBREVIATIONS.

<u>Abbrev.</u>	<u>Intended Word</u>	<u>Word Erroneously Given</u>
ACC	Accident	Access (Road)
CLRS	Clears	Colors
DLY	Delay	Daily
FDR	Feeder	Federal
L	Left	Lane (merge)
LOC	Local	Location
LT	Light (traffic)	Left
PARK	Parking	Park
POLL	Pollution (index)	Poll
RED	Reduce	Red
STAD	Stadium	Standard

Traffic Control Plan  
Page 11 of 12

TEMP  
WRNG

Temporary  
Warning

Temperature  
Wrong

**TYPICAL MESSAGES**

The following is a list of typical messages used on CMS. The list consists of the reason or problem that you want the driver to be aware of and the action that you want the driver to take.

**Reason/Problem**

ACCIDENT  
ACCIDENT/XX MILES  
XX ROAD CLOSED  
XX EXIT CLOSED  
BRIDGE CLOSED  
BRIDGE/(SLIPPERY, ICE, ETC.)  
CENTER/LANE/CLOSED  
DELAY(S), MAJOR/DELAYS  
DEBRIS AHEAD  
DENSE FOG  
DISABLED/VEHICLE  
EMER/VEHICLES/ONLY  
EVENT PARKING  
EXIT XX CLOSED  
FLAGGER XX MILES  
FOG XX MILES  
FREEWAY CLOSED  
FRESH OIL  
HAZMAT SPILL  
ICE  
INCIDENT AHEAD  
LANES (NARROW, SHIFT, MERGE, ETC.)  
LEFT LANE CLOSED  
LEFT LANE NARROWS  
LEFT 2 LANES CLOSED  
LEFT SHOULDER CLOSED  
LOOSE GRAVEL  
MEDIAN WORK XX MILES  
MOVING WORK ZONE, WORKERS IN ROADWAY  
NEXT EXIT CLOSED  
NO OVERSIZED LOADS  
NO PASSING  
NO SHOULDER  
ONE LANE BRIDGE

**Action**

ALL TRAFFIC EXIT RT  
AVOID DELAY USE XX  
CONSIDER ALT ROUTE  
DETOUR  
DETOUR XX MILES  
DO NOT PASS  
EXPECT DELAYS  
FOLLOW ALT ROUTE  
KEEP LEFT  
KEEP RIGHT  
MERGE XX MILES  
MERGE LEFT  
MERGE RIGHT  
ONE-WAY TRAFFIC  
PASS TO LEFT  
PASS TO RIGHT  
PREPARE TO STOP  
REDUCE SPEED  
SLOW  
SLOW DOWN  
STAY IN LANE  
STOP AHEAD  
STOP XX MILES  
TUNE RADIO 1610 AM  
USE NN ROAD  
USE CENTER LANE  
USE DETOUR ROUTE  
USE LEFT TURN LANE  
USE NEXT EXIT  
USE RIGHT LANE  
WATCH FOR FLAGGER

## Traffic Control Plan

Page 12 of 12

PEOPLE CROSSING  
RAMP CLOSED  
RAMP (SLIPPERY, ICE, ETC.)  
RIGHT LANE CLOSED  
RIGHT LANE NARROWS  
RIGHT SHOULDER CLOSED  
ROAD CLOSED  
ROAD CLOSED XX MILES  
ROAD (SLIPPERY, ICE, ETC.)  
ROAD WORK  
ROAD WORK (OR CONSTRUCTION) (TONIGHT, TODAY, TOMORROW, DATE)  
ROAD WORK XX MILES  
SHOULDER (SLIPPERY, ICE, SOFT, BLOCKED, ETC.)  
NEW SIGNAL XX MILES  
SLOW 1 (OR 2) - WAY TRAFFIC  
SOFT SHOULDER  
STALLED VEHICLES AHEAD  
TRAFFIC BACKUP  
TRAFFIC SLOWS  
TRUCK CROSSING  
TRUCKS ENTERING  
TOW TRUCK AHEAD  
UNEVEN LANES  
WATER ON ROAD  
WET PAINT  
WORK ZONE XX MILES  
WORKERS AHEAD

DURABLE PAVEMENT EDGE DETAIL

(Resurfacing adjacent to fill slope or ditch foreslope that is 3:1 or less)

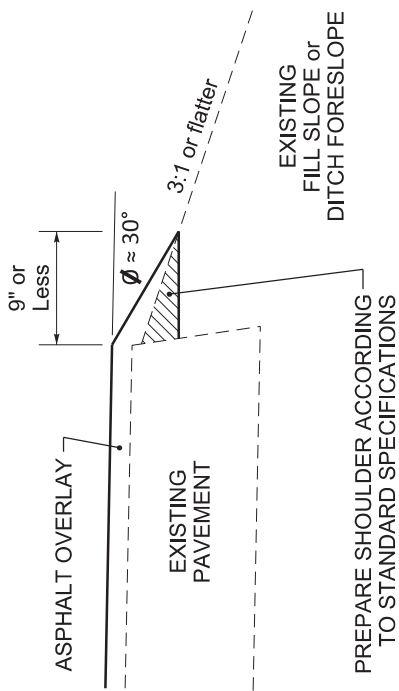

DURABLE PAVEMENT EDGE DETAIL

(Resurfacing adjacent to fill slope or ditch foreslope that is steeper than 3:1)

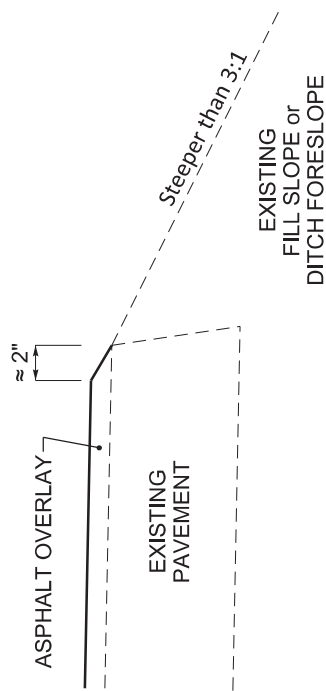

NOTES

1. DETAILS DO NOT APPLY TO OVERLAYS LESS THAN 1 INCH THICK.
2. THE DURABLE PAVEMENT EDGE DEVICE MAY BE DISENGAGED AT DRIVEWAYS, SIDE STREETS, HIGH SHOULDERS, AND OTHER LOCATIONS NOT FEASIBLE TO CONSTRUCT, AS APPROVED BY THE ENGINEER.

DURABLE PAVEMENT EDGE  
DETAILS

DRAWING NOT TO SCALE

DURABLE PAVEMENT EDGE DETAIL

(Resurfacing adjacent to low shoulder with dropoff of 5 inches or less)

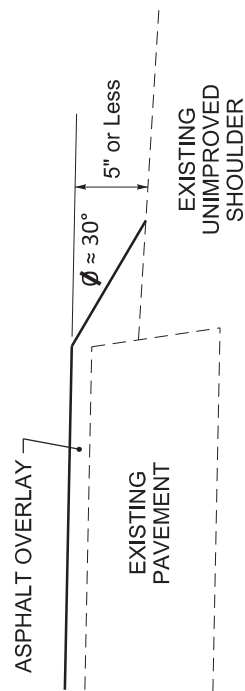

DURABLE PAVEMENT EDGE DETAIL

(Resurfacing adjacent to low shoulder with dropoff of more than 5 inches)

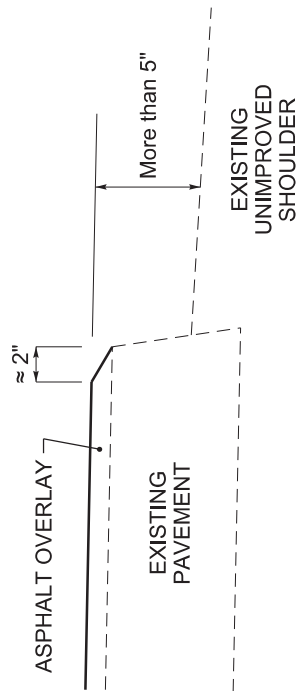

DURABLE PAVEMENT EDGE DETAIL

(Resurfacing adjacent to an obstruction, such as an existing headwall)

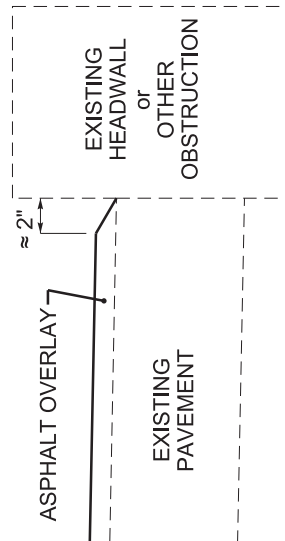

(FD05 001 0061 010-013)

## **SPECIAL NOTE FOR TRAFFIC SIGNAL LOOP DETECTORS**

**1.0 DESCRIPTION.** Be advised that there are existing traffic signal loop detectors within the construction limits of this project. Except as specified herein, perform traffic signal loop replacement in accordance with the Department's Standard/Supplemental Specifications, Special Provisions, Special Notes, and Standard/Sepia Drawings, current editions and as directed by the Engineer. Article references are to the Standard Specifications. Furnish all materials, labor, equipment, and incidentals for replacement of traffic signal loop installation(s) and all other work specified as part of this contract.

**1.1 Pre-bid Requirements.** Conform to Subsection 723.03.17

**2.0 MATERIALS.** Except as specified herein, furnish materials in accordance with Subsection 732.02 and Section 835. Provide for materials to be sampled and tested in accordance with the Department's Sampling Manual. Make materials available for sampling a sufficient time in advance of the use of the materials to allow for the necessary time for testing, unless otherwise specified in this Special Note.

**2.1 Maintain and Control Traffic.** See Traffic Control Plan.

**2.2 Sand.** Furnish natural sand meeting the requirements of Subsection 804.04.01.

**2.3 Seeding.** Furnish Seed Mix Type I.

**2.4 Loop Saw Slot and Fill.** Furnish loop sealant, backer rod, and non-shrink grout according to the Saw Slot Detail.

**2.5 Junction Boxes.** Furnish junction box type B, #57 aggregate, and geotextile filter type IV according to junction box detail.

**2.6 Cable No. 14/1 Pair (Lead-in).** Furnish cable that is specified in Section 835. Cable shall be ran splice free. This shall include splice kits to connect to the loop wire.

**2.7 Conduit.** Furnish and install appropriate conduit from transitions to the roadway, junction boxes and poles. See details below.

**3.0 CONSTRUCTION.** Except as specified herein, install and test Traffic Signal Loop Detectors in accordance with Section 723 and the drawings.

**3.1 Testing.** Conform to Subsection 723.03.17 (A)

**3.2 Coordination.** Conform to Subsection 723.03.17 (B)

**3.3 Connection.** Conform to Subsection 723.03.17 (C)

**3.4 Maintain and Control Traffic.** See Traffic Control Plan.

**3.5 Milling.** Conform to Subsection 723.03.17 (F)

**3.6 Loop Saw Slot and Fill.** Conform to Subsection 723.03.13 (A).

Traffic Signal Loop Detectors  
Page 2 of 9

**3.7 Backfilling and Disturbed Areas.** Conform to Subsection 723.03.11.

**3.8 Removal.** Conform to Subsection 723.03.16.

**3.9 Property/Roadway Damage.** Conform to Subsection 723.03.17 (J).

**3.10 Right-of-Way Limits.** Conform to Subsection 723.03.17 (K).

**3.11 Utility Clearance.** Conform to Subsection 716.03.01.

**3.12 Control.** Obtain the Engineer’s approval of all designs required to be furnished by the Contractor prior to incorporation into the work. The Department reserves the right to permit other contractors, state forces, public utility companies, and others to do work during the construction within the limits of, or adjacent to, the project. Conduct operations and cooperate with such other parties so that interference with each other’s work will be reduced to a minimum. The Contractor agrees to make no claims against the Department for additional compensation due to delays or other conditions created by the operations of such other parties. Should a difference of opinion arise as to the rights of the Contractor and others working within the limits of, or adjacent to, the project, the Engineer will decide as to the respective rights of the various parties involved in order to ensure the completion of the work in general harmony and in a satisfactory manner, and the Engineer’s decision shall be final and binding upon the Contractor.

**3.13 Bore and Jack.** Conform to Subsection 723.03.06 (I).

**3.14 Open Cut Roadway.** Conform to Subsection 723.03.06 (I).

**4.0 MEASUREMENT.** See Subsection 723.04 for bid item notes. Additional bid items include the following:

**4.1 Loop Test.** The Department will measure the quantity as each individual unit loop tested. The Department will not measure disconnection, reconnection, traffic control, re-splicing per specifications, before and after testing per note above, and any associated hardware for payment and will consider them incidental to this item of work.

**4.2 Remove Signal Equipment.** The department will measure the quantity by each. The department will not measure backfilling and the disposal or transportation of equipment and materials associated with any structural or electrical component of the signal system including, but not limited to pole bases, poles, junction boxes, cabinets, and wood poles for payment and will consider them incidental to this item of work.

**5.0 PAYMENT.** The Department will make payment for the completed and accepted quantities of listed items according to Subsection 723.05 in addition to the following:

<u>Code</u>	<u>Pay Item</u>	<u>Pay Unit</u>
Conduit 1”	4792	Linear Foot
PVC Conduit – 1 ¼ inch – sch 80	24900EC	Linear Foot



Traffic Signal Loop Detectors  
Page 3 of 9

PVC Conduit – 2 inch – sch 80	24901EC	Linear Foot
Conduit 2”	4795	Linear Foot
Electrical Junction Box type B	4811	Each
Loop Test	24963ED	Each
Trenching and Backfilling	4820	Linear Foot
Loop Wire	4830	Linear Foot
Cable-No. 14/1 Pair	4850	Linear Foot <sup>1</sup>
Loop Saw Slot and Fill	4895	Linear Foot <sup>1</sup>
Bore and Jack Conduit	21543EN	Linear Foot <sup>3</sup>
Open Cut Roadway	4821	Linear Foot <sup>3</sup>
Remove Signal Equipment	24955ED	each

The Department will consider payment as full compensation for all work required under these notes and the Standard Specifications.

Contrary to section 723:

SUBSECTION: 03.13 Loop Installation.

REVISION: Replace first sentence note with the following:

twist unshielded loop wire (imsa 51-7) with 3 to 5 turns from the start of homerun to the inside conduit, junction box, cabinet, or pole. Twist unshielded loop wires (imsa 51-7) with 3 to 5 turns per foot from the start of the homerun to the junction box, cabinet, or pole. Slot can be widen to .5" to .625" to help with the installation of the twisted wire.

# Traffic Signal Loop Detectors

Page 4 of 9

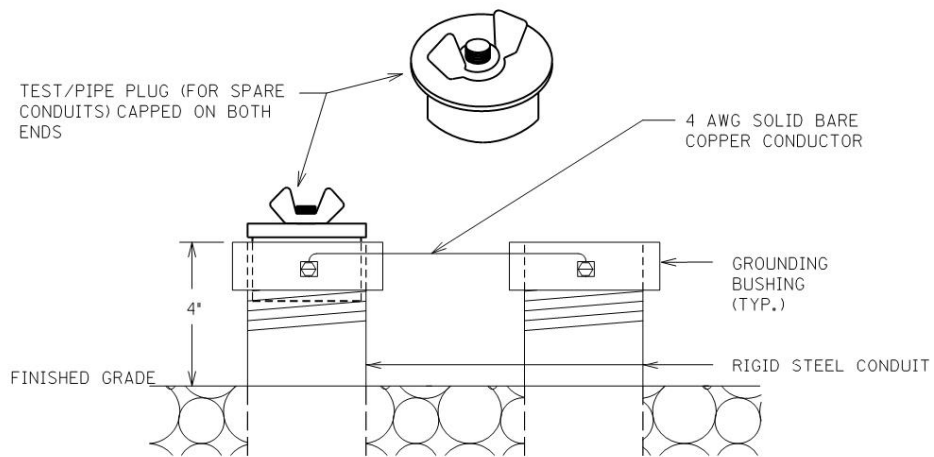

TEST/PIPE PLUG(FOR SPARE CONDUITS) AND GROUNDING DETAIL

Traffic Signal Loop Detectors  
Page 5 of 9

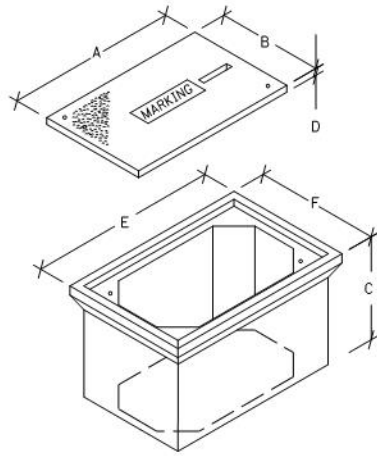

JUNCTION BOX DIMENSIONS (NOMINAL)						
	A	B	C	D	E	F
TYPE A	23"	14"	27"	2"	25"	15"
TYPE B	18"	11"	12"	1 3/4"	20"	13"
TYPE C	36"	24"	30"	3"	38"	26"

• MINIMUM  
NOTE: STACKABLE BOXES ARE PERMITTED

BEFORE THE INSTALLATION OF THE #57 AGGREGATE AND JUNCTION BOX, THE CONTRACTOR SHALL INSTALL GEOTEXTILE FILTER FABRIC TYPE IV IN THE HOLE. THE FABRIC SHALL EXTEND TO JUST BELOW THE LIP OF THE JUNCTION BOX AND SHALL BE CONTINUOUSLY ADHERED TO THE EXTERIOR OF THE BOX WITH ADHESIVE. ANY LOCATIONS WHERE CONDUITS ENTER THE BOX, THE FABRIC SHALL BE 'X CUT' ONLY AS MUCH AS NECESSARY TO ALLOW PASSAGE OF EACH INDIVIDUAL CONDUIT THROUGH THE FABRIC. THE FABRIC SHALL BE INCIDENTAL TO BID ITEMS 481I, 2039INS835, OR 20392NS835.

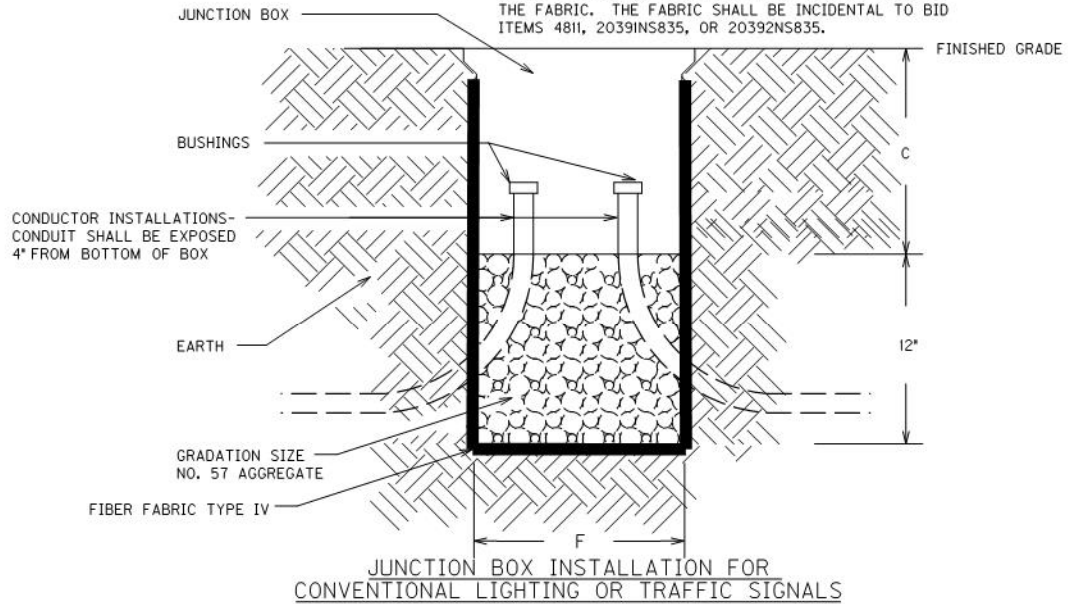

JUNCTION BOX INSTALLATION FOR CONVENTIONAL LIGHTING OR TRAFFIC SIGNALS

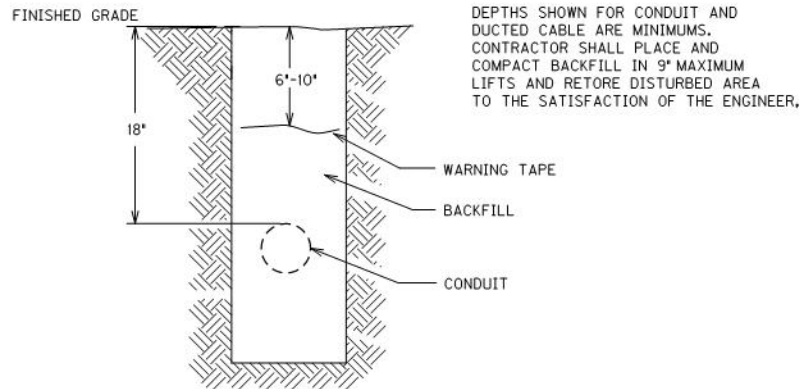

CONDUIT AND WARNING TAPE TRENCH

# Traffic Signal Loop Detectors

## Page 6 of 9

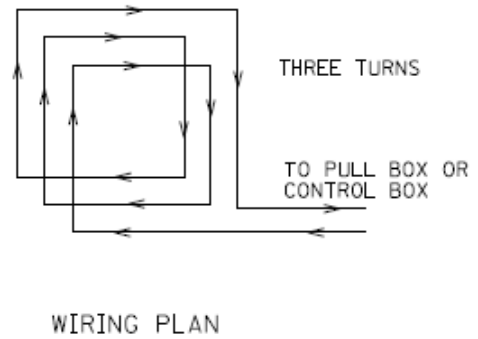
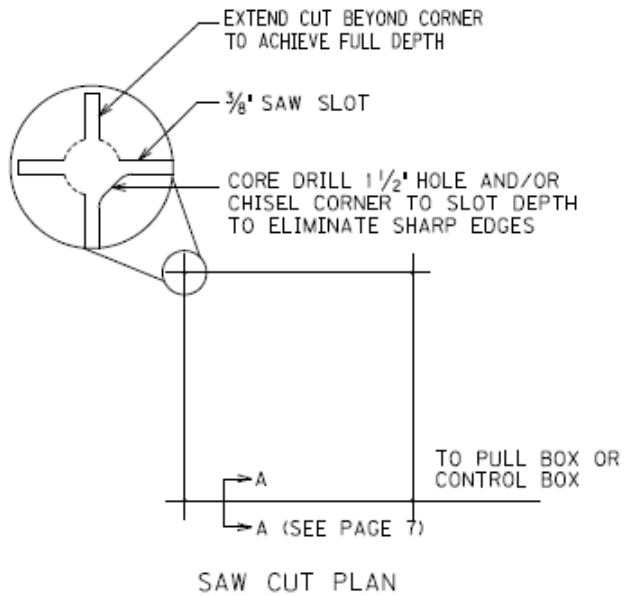

6'X6' LOOP

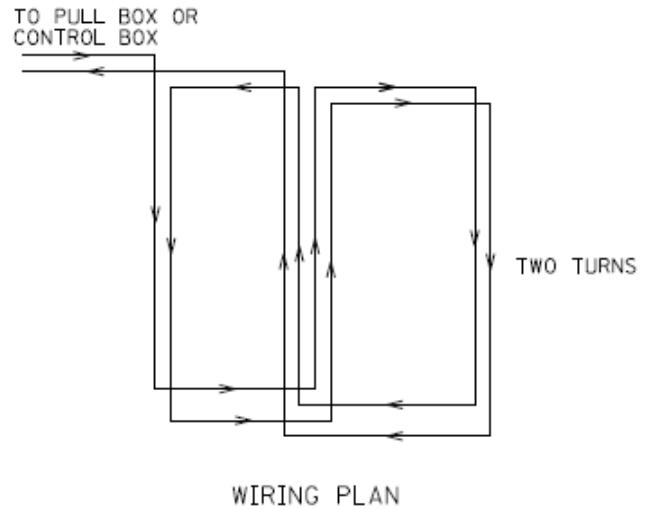
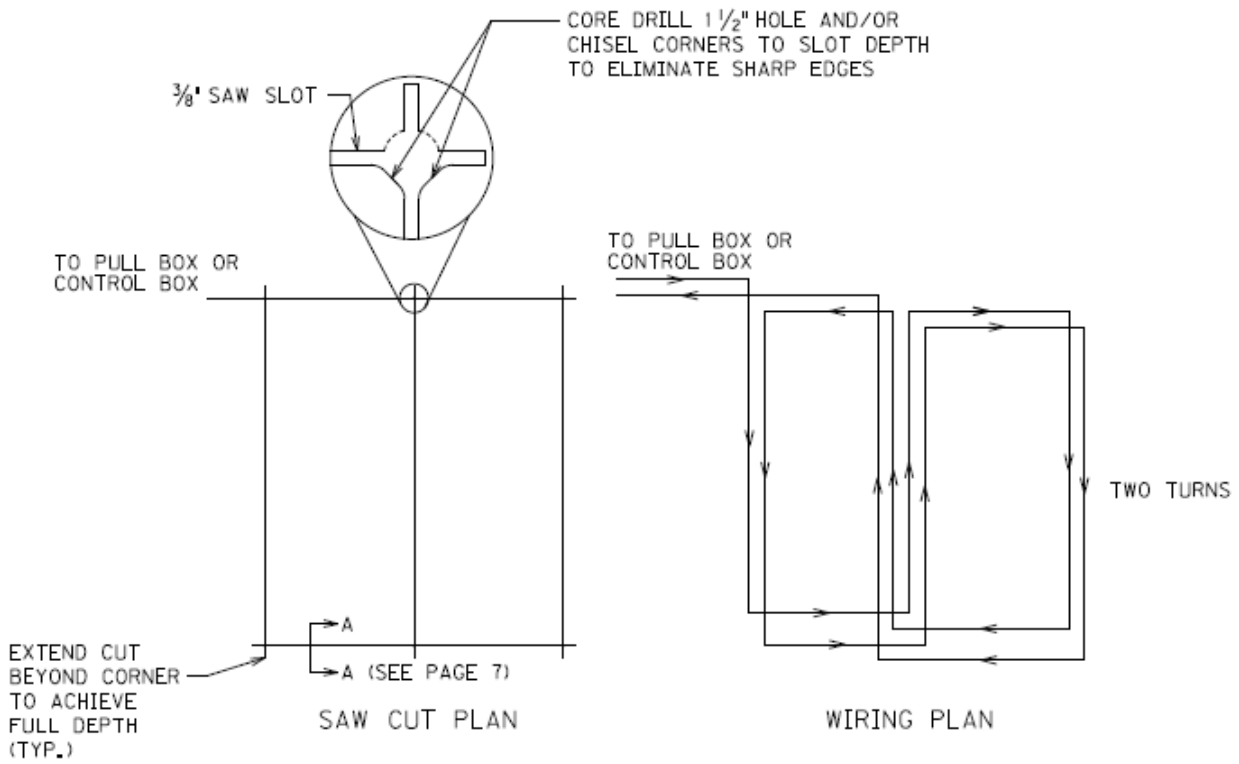

6'X30' QUADRAPOLE LOOP

# Traffic Signal Loop Detectors

Page 7 of 9

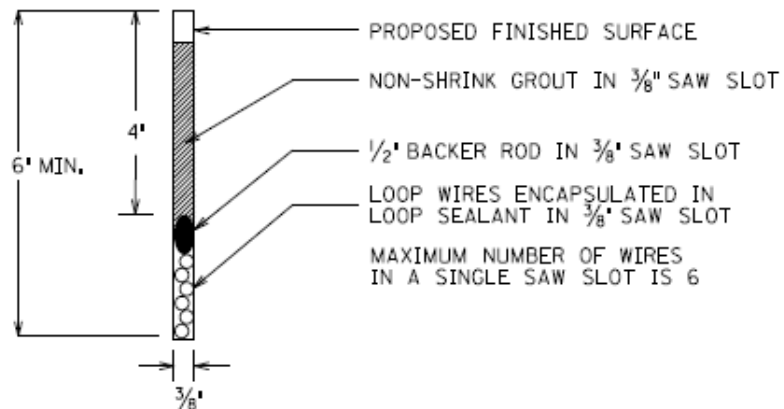

SECTION A-A (SAW SLOT DETAIL)

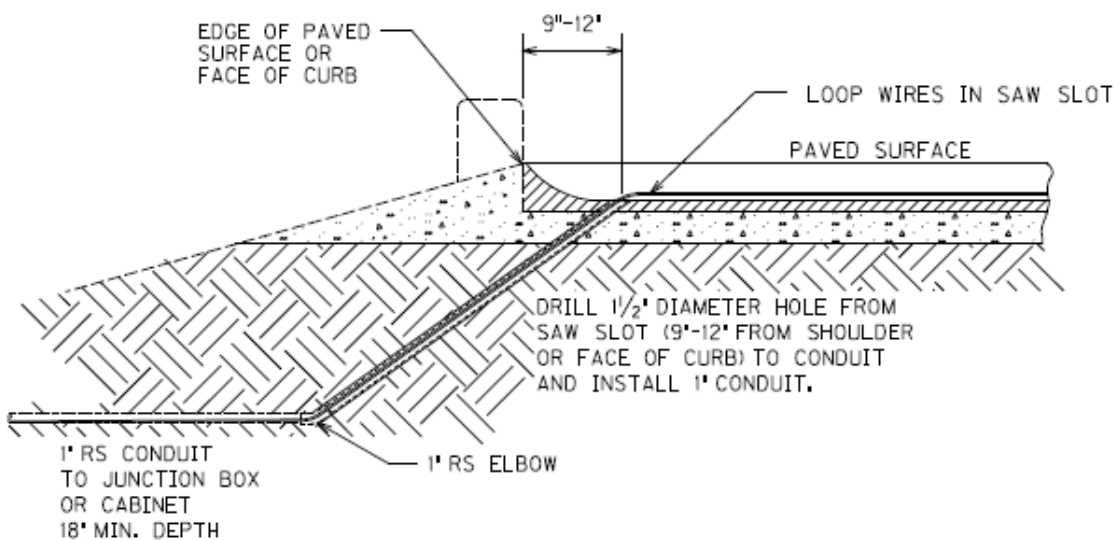

SAW SLOT EDGE OF PAVEMENT TRANSITION

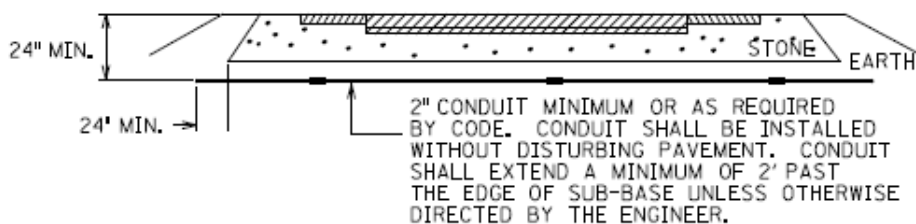

CONDUIT UNDER EXISTING PAVEMENT DETAIL

# Traffic Signal Loop Detectors

## Page 8 of 9

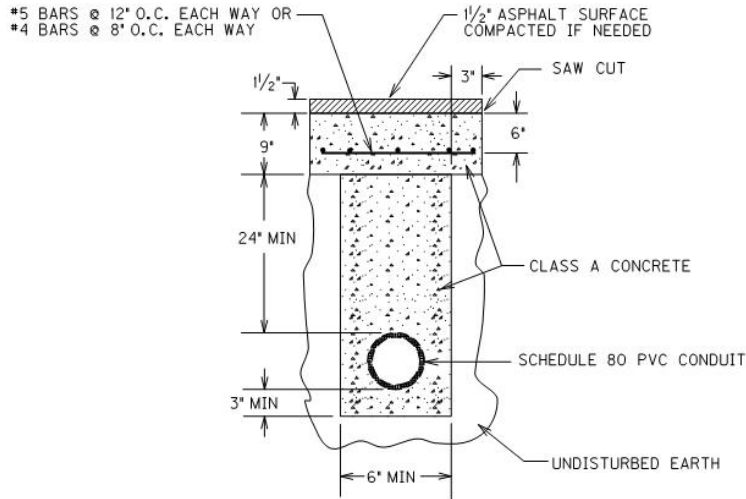

OPEN CUT PAVEMENT DETAIL

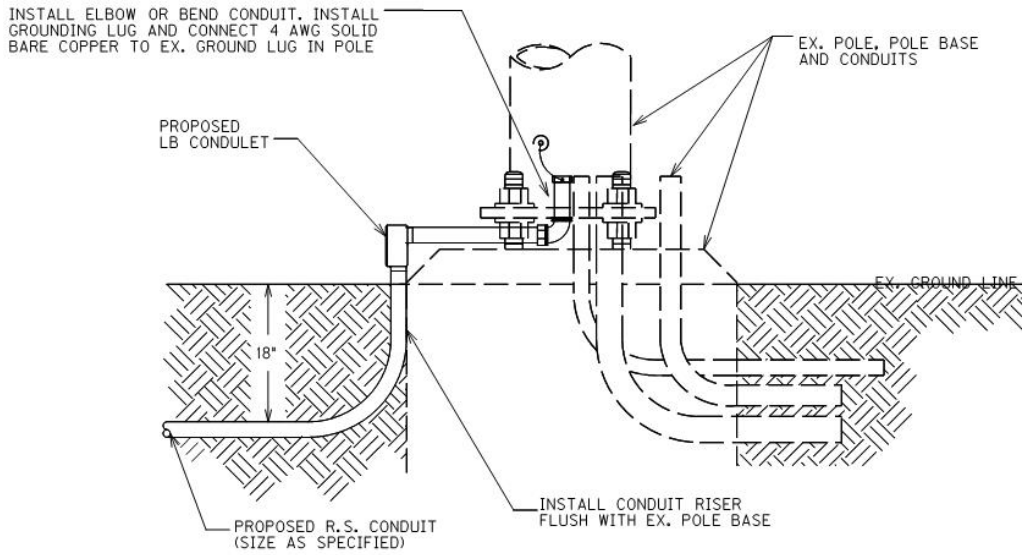

CONDUIT INSTALLATION IN EX. POLE BASE

# Traffic Signal Loop Detectors

## Page 9 of 9

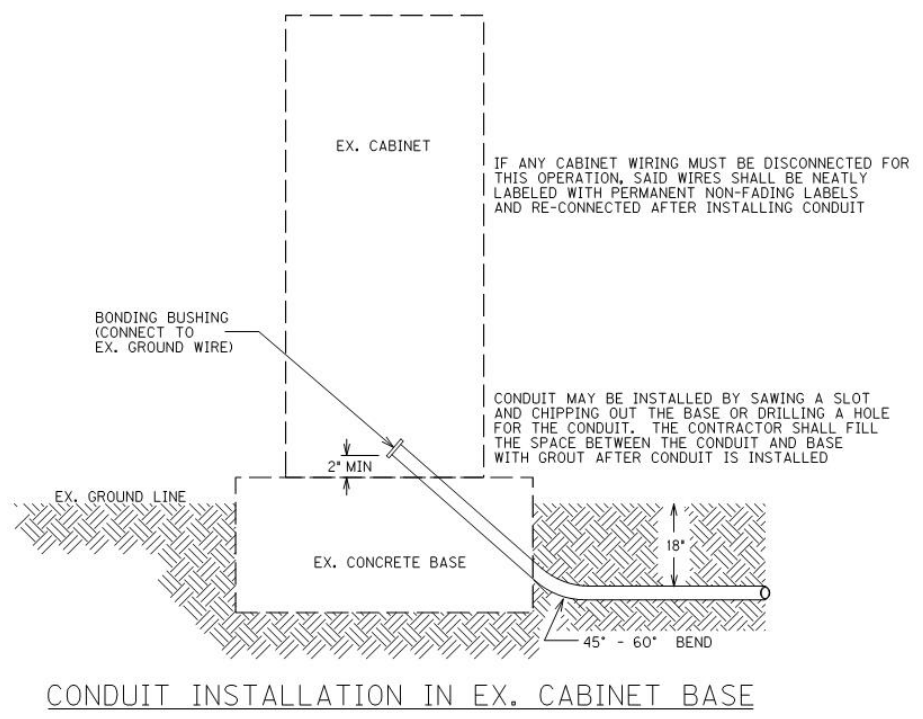

Update: 4-5-2022

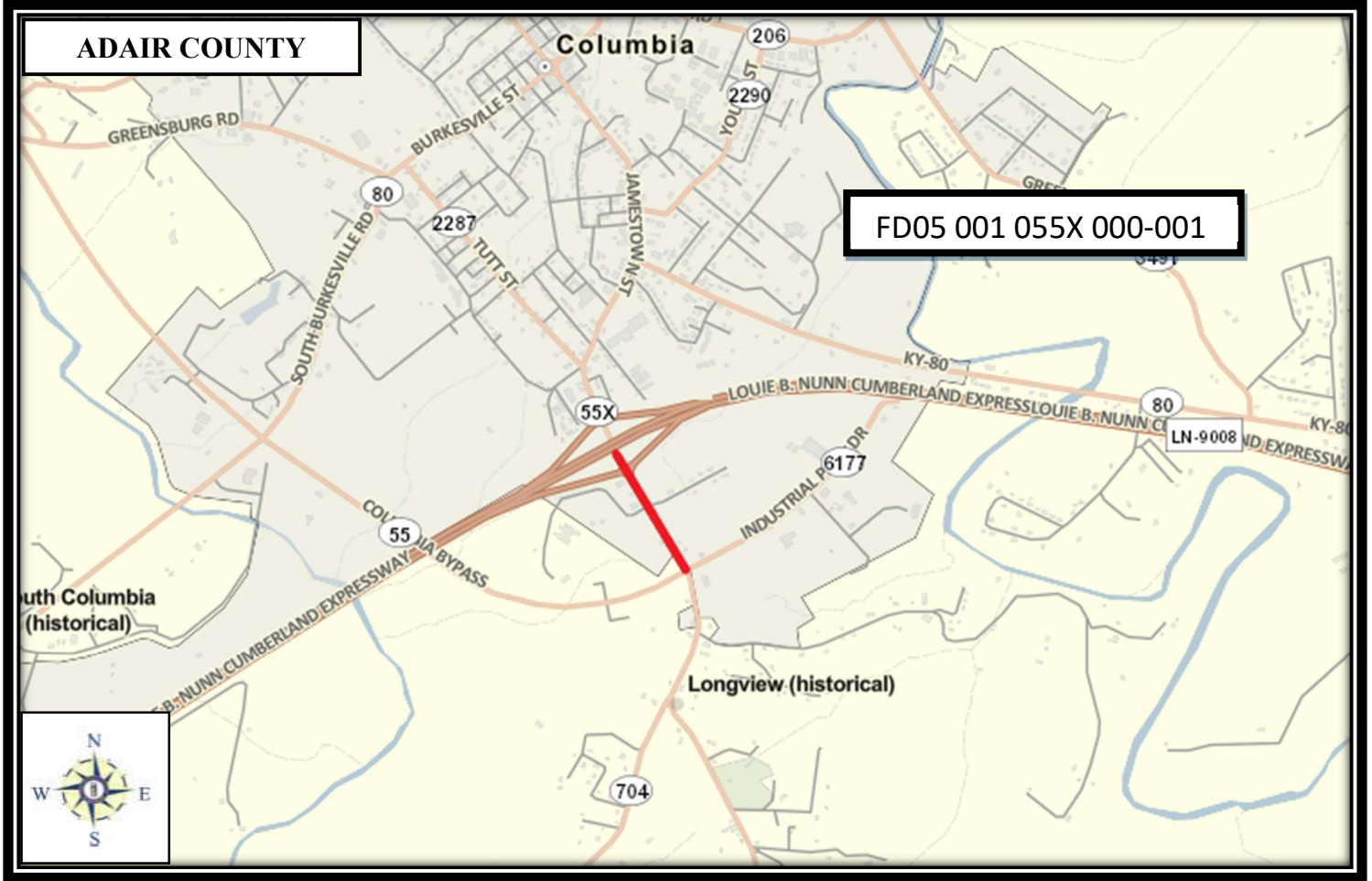



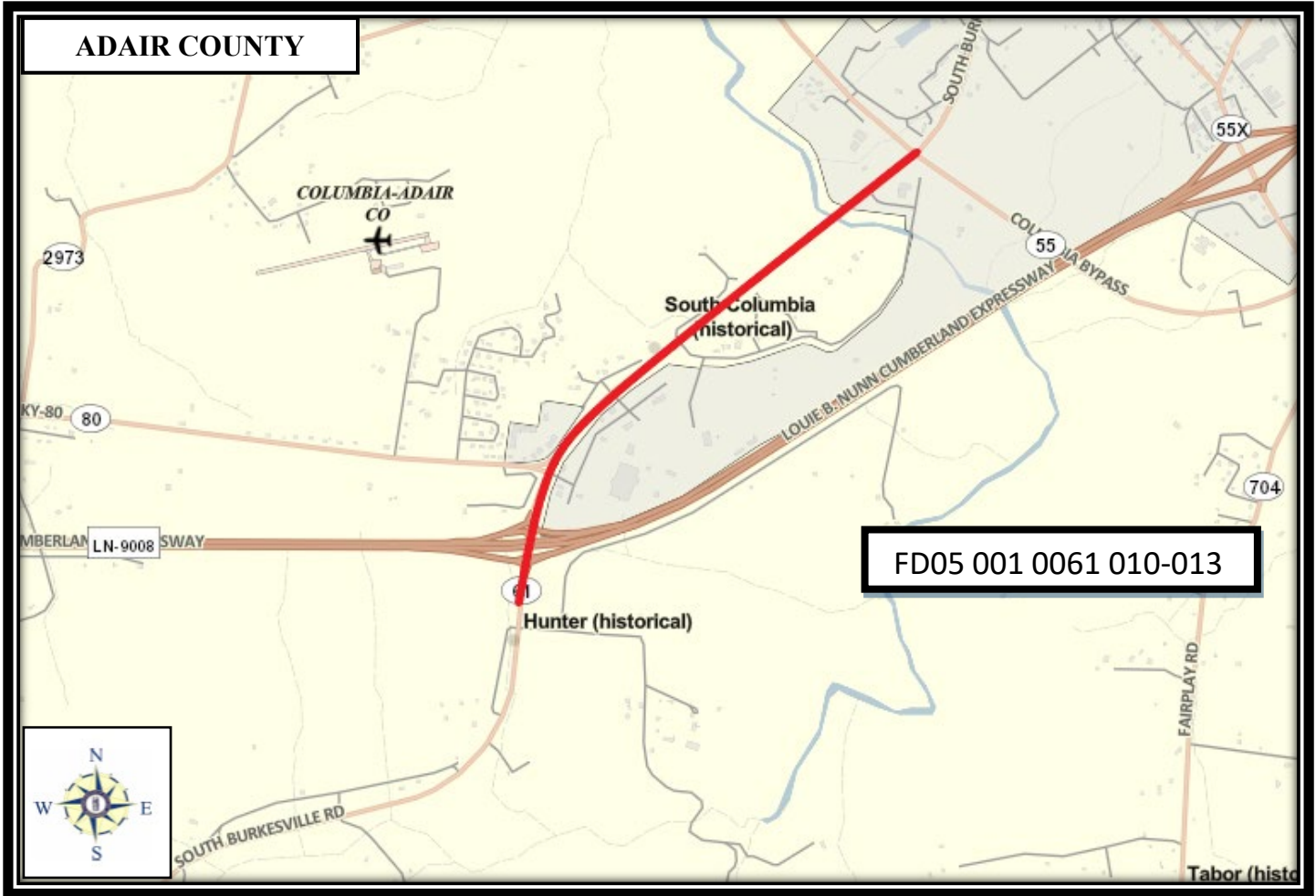

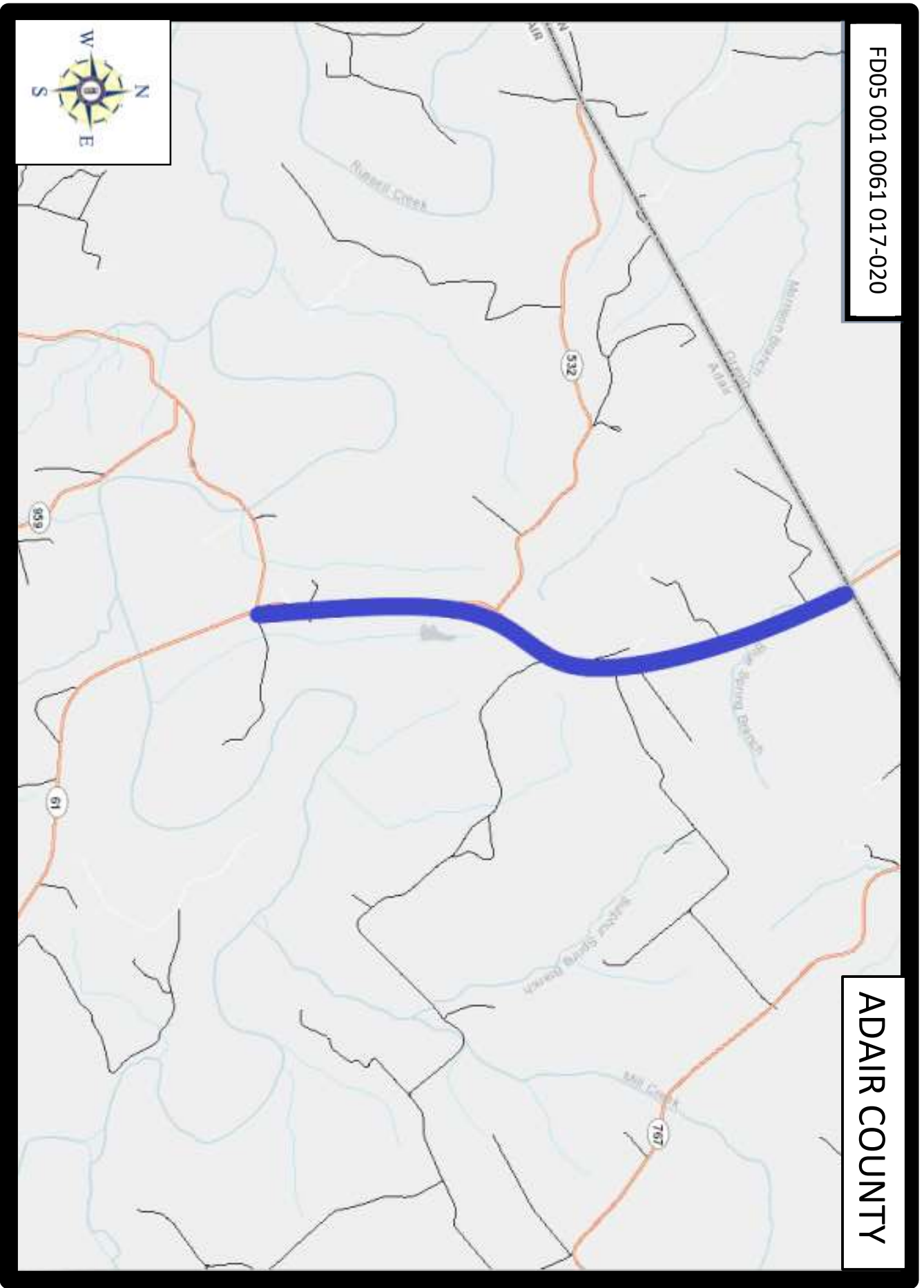

# MATERIAL SUMMARY

**CONTRACT ID: 222287**

**001GR22P047-FD05**

**MP00100612301**

COLUMBIA - GREENSBURG ROAD (KY 61) FROM KY 768 EXTENDING NORTH TO GREEN COUNTY LINE ASPHALT RESURFACING, A DISTANCE OF 2.55 MILES.

Project Line No	Bid Code	DESCRIPTION	Quantity	Unit
0065	00190	LEVELING & WEDGING PG64-22	273.00	TON
0070	00301	CL2 ASPH SURF 0.38D PG64-22	2,340.00	TON
0075	00356	ASPHALT MATERIAL FOR TACK	20.00	TON
0080	02562	TEMPORARY SIGNS	350.00	SQFT
0085	02585	EDGE KEY	400.00	LF
0090	02650	MAINTAIN & CONTROL TRAFFIC - (KY 61, MP 17-20)	1.00	LS
0095	02697	EDGELINE RUMBLE STRIPS	26,950.00	LF
0100	06510	PAVE STRIPING-TEMP PAINT-4 IN	7,500.00	LF
0105	06542	PAVE STRIPING-THERMO-6 IN W	27,000.00	LF
0110	06543	PAVE STRIPING-THERMO-6 IN Y	18,250.00	LF
0115	06568	PAVE MARKING-THERMO STOP BAR-24IN	50.00	LF
0120	02569	DEMOBILIZATION	1.00	LS

# MATERIAL SUMMARY

**CONTRACT ID: 222287**

**001GR22P047-FD05**

**MP00100612303**

BURKESVILLE - COLUMBIA ROAD (KY 61) 530 FEET NORTH OF GOLDENROD LANE EXTENDING TO KY 55 ASPHALT RESURFACING, A DISTANCE OF 1.71 MILES.

Project Line No	Bid Code	DESCRIPTION	Quantity	Unit
0125	00190	LEVELING & WEDGING PG64-22	508.00	TON
0130	00301	CL2 ASPH SURF 0.38D PG64-22	1,250.00	TON
0135	00356	ASPHALT MATERIAL FOR TACK	41.00	TON
0140	00388	CL3 ASPH SURF 0.38B PG64-22	4,560.00	TON
0145	02562	TEMPORARY SIGNS	290.00	SQFT
0150	02650	MAINTAIN & CONTROL TRAFFIC - (KY 61, MP 10-13)	1.00	LS
0155	02671	PORTABLE CHANGEABLE MESSAGE SIGN	2.00	EACH
0160	02676	MOBILIZATION FOR MILL & TEXT - (KY 61, MP 10-13)	1.00	LS
0165	02677	ASPHALT PAVE MILLING & TEXTURING	1,410.00	TON
0170	02696	SHOULDER RUMBLE STRIPS	15,600.00	LF
0175	02775	ARROW PANEL	2.00	EACH
0180	04792	CONDUIT-1 IN	110.00	LF
0185	04811	ELECTRICAL JUNCTION BOX TYPE B	11.00	EACH
0190	04820	TRENCHING AND BACKFILLING	1,330.00	LF
0195	04830	LOOP WIRE	3,450.00	LF
0200	04850	CABLE-NO. 14/1 PAIR	6,775.00	LF
0205	04895	LOOP SAW SLOT AND FILL	1,428.00	LF
0210	06510	PAVE STRIPING-TEMP PAINT-4 IN	20,000.00	LF
0215	06542	PAVE STRIPING-THERMO-6 IN W	24,600.00	LF
0220	06543	PAVE STRIPING-THERMO-6 IN Y	37,000.00	LF
0225	06568	PAVE MARKING-THERMO STOP BAR-24IN	408.00	LF
0230	06569	PAVE MARKING-THERMO CROSS-HATCH	1,726.00	SQFT
0235	06574	PAVE MARKING-THERMO CURV ARROW	44.00	EACH
0240	06575	PAVE MARKING-THERMO COMB ARROW	2.00	EACH
0245	06576	PAVE MARKING-THERMO ONLY	2.00	EACH
0250	06578	PAVE MARKING-THERMO MERGE ARROW	3.00	EACH
0255	06600	REMOVE PAVEMENT MARKER TYPE V	529.00	EACH
0260	10020NS	FUEL ADJUSTMENT	13,368.00	DOLL
0265	10030NS	ASPHALT ADJUSTMENT	33,576.00	DOLL
0270	24679ED	PAVE MARK THERMO CHEVRON	625.00	SQFT
0275	24900EC	PVC CONDUIT-1 1/4 IN-SCHEDULE 80	820.00	LF
0280	24901EC	PVC CONDUIT-2 IN-SCHEDULE 80	210.00	LF
0285	24955ED	REMOVE SIGNAL EQUIPMENT	2.00	EACH
0290	24963ED	LOOP TEST	17.00	EACH
0295	02569	DEMOBILIZATION	1.00	LS

# MATERIAL SUMMARY

**CONTRACT ID: 222287**

**001GR22P047-FD05**

**MP001055X2301**

JAMESTOWN STREET (KY 55X) FROM KY 6177/KY 55 EXTENDING NORTH TO CUMBERLAND PARKWAY  
OVERPASS ASPHALT RESURFACING, A DISTANCE OF .39 MILES.

Project Line No	Bid Code	DESCRIPTION	Quantity	Unit
0005	00190	LEVELING & WEDGING PG64-22	64.00	TON
0010	00356	ASPHALT MATERIAL FOR TACK	5.00	TON
0015	00388	CL3 ASPH SURF 0.38B PG64-22	775.00	TON
0020	02562	TEMPORARY SIGNS	250.00	SQFT
0025	02650	MAINTAIN & CONTROL TRAFFIC - (KY 55X)	1.00	LS
0030	02676	MOBILIZATION FOR MILL & TEXT - (KY 55X)	1.00	LS
0035	02677	ASPHALT PAVE MILLING & TEXTURING	775.00	TON
0040	06510	PAVE STRIPING-TEMP PAINT-4 IN	3,000.00	LF
0045	06515	PAVE STRIPING-PERM PAINT-6 IN	10,000.00	LF
0050	06568	PAVE MARKING-THERMO STOP BAR-24IN	88.00	LF
0055	06574	PAVE MARKING-THERMO CURV ARROW	9.00	EACH
0060	02569	DEMOBILIZATION	1.00	LS



## Milling Summary FD05 001 0061 010-013

					Total	1410
Milepoint	Comment	Length	Avg. Width	Avg Depth	Tons	
10.500	Begin Proj to Bridge	586	60	1.25	269	
10.653	Bridge to 10.92 MP	1410	95	1.25	1023	
					0	
11.127	Will Walker Rd	25	48	0.625	5	
11.127	Patricia Trl	20	60	0.625	5	
					0	
11.364	Mt. View Rd	25	30	0.625	3	
11.364	Burkesville Loop	25	30	0.625	3	
					0	
11.865	Petty's Fork Bridge	150	82	0.625	47	
11.998	Petty's Fork Bridge	150	82	0.625	47	
					0	
12.036	Burk. Loop Conn	25	60	0.625	6	
					0	
					0	
					0	
					0	
					0	
					0	
					0	
					0	
					0	
					0	
					0	
					0	
					0	
					0	
					0	
					0	
					0	
					0	
					0	
					0	
					0	
					0	
					0	
					0	
					0	
					0	

**NOTE:** Milling at MP 10.500 and 10.653 includes radius to CP Ramps, KY 80, and Don Franklin Drive

**Adair County  
TRAFFIC LOOP SUMMARY  
FD05 001 0061 010-013**

MPT.	INTERSECTION	SAW, SLOT AND FILL		CABLE RIGID STEEL NO.14		PVC SCHEDULE 80 CONDUIT 1 1/4 IN		PVC SCHEDULE 80 CONDUIT 1 1/2 IN		PVC SCHEDULE 80 CONDUIT 2 IN		JUNCTION TYBEB		TRENCHING AND BACKFILLING		REMOVE UNUSED SIGNAL EQUIPMENT		TEST EA
		LF	EA	LF	EA	LF	EA	LF	EA	LF	EA	EA	EA	EA	EA	EA	EA	
10.843	KY 61 @ KY 80 West & Walmart																	
	KY 61 South Leg	336	1500	30	190	0	0	0	0	0	0	3	430					5
	KY 61 North Leg	336	2420	30	190	0	0	0	0	210	3	430						5
	KY 80 West	252	530	10	20	0	0	0	0	0	1	20						2
	Walmart	252	530	10	20	0	0	0	0	0	1	20						2
12.213	KY 55 & KY 80 @ KY 61																	
	South KY 61	252	1795	30	400	0	0	0	0	0	3	430						3
		1428	3450	6775	110	820	0	0	0	210	11	1330						17

**NOTES:**

- Quantities are for estimating purposes only. The Contractor shall field measure items to verify quantities.
- For loops that are to be replaced, 1" RIGID STEEL conduit SHALL be installed at transition under edge of road & into junction box for each loop as per Division of Traffic detail sheets.
- Replace any junction boxes that are damaged and/or holding water in accordance to Division of Traffic detail sheets.
- Replace any disturbed sidewalk required for installation of replacement junction boxes and conduit at no additional cost to the department.
- Reuse existing conduit as much as possible. Replace any damaged conduit and conduit needed to meet current NEC requirements.
- 2 - 1 1/4 inch conduits may be used in place of 2" conduit.



**Adair County**  
**THERMOPLASTIC INTERSECTION PAVEMENT MARKINGS SUMMARY**  
**FD05 001 0061 010-013**

MPT.	INTERSECTION	X-WALKS 6 INCH		STP BARS 24 INCH		CURVE		ARROWS		"ONLY"		"STOP"		CHEVRON		CROSS HATCH	
		LF	EA	LF	EA	EA	EA	EA	EA	EA	EA	SF	SF				
	C.P. Eastbd Exit Ramp			22		2											
	C.P. Eastbd Turn LN					2											
	C.P. Westbd Turn LN					2											
	C.P. Westbd Exit Ramp			22		2											
	Don Franklin Rt. Turn LN					6											
10.843	KY 80			58		1					1				625		
10.843	Don Franklin Dr			48		1					1						
	KY 80 Turn Lane			40		4											
	Don Franklin Turn LN			40		4											
	Will Walker Rd Turn LN					3											
11.127	Will Walker Rd			24													
11.127	Patricia Trl			24													
	Patricia Trl Turn LN					4											
	Mt. View Ln Turn LN					2											
11.364	Mt. View Ln			30													
11.364	Burkesville Loop			30													
	Burks. Loop Turn LN					2											
12.036	Burks. Loop Conn			30													
	Burks. Lp. Conn Turn LN					2											
	KY 55 LT Turn LN					4											
	KY 55 Rt Turn LN					3											
12.213	KY 55			40								2					1726
<b>TOTAL</b>		<b>0</b>		<b>408</b>		<b>44</b>		<b>0</b>		<b>2</b>		<b>0</b>		<b>625</b>		<b>1726</b>	<b>0</b>

Note: Striping has been altered from existing conditions at signalized intersections.





ADAIR COUNTY  
FD05 001 055X 000-001  
TYPICAL SECTION  
MILEPOINTS 0.000-0.090

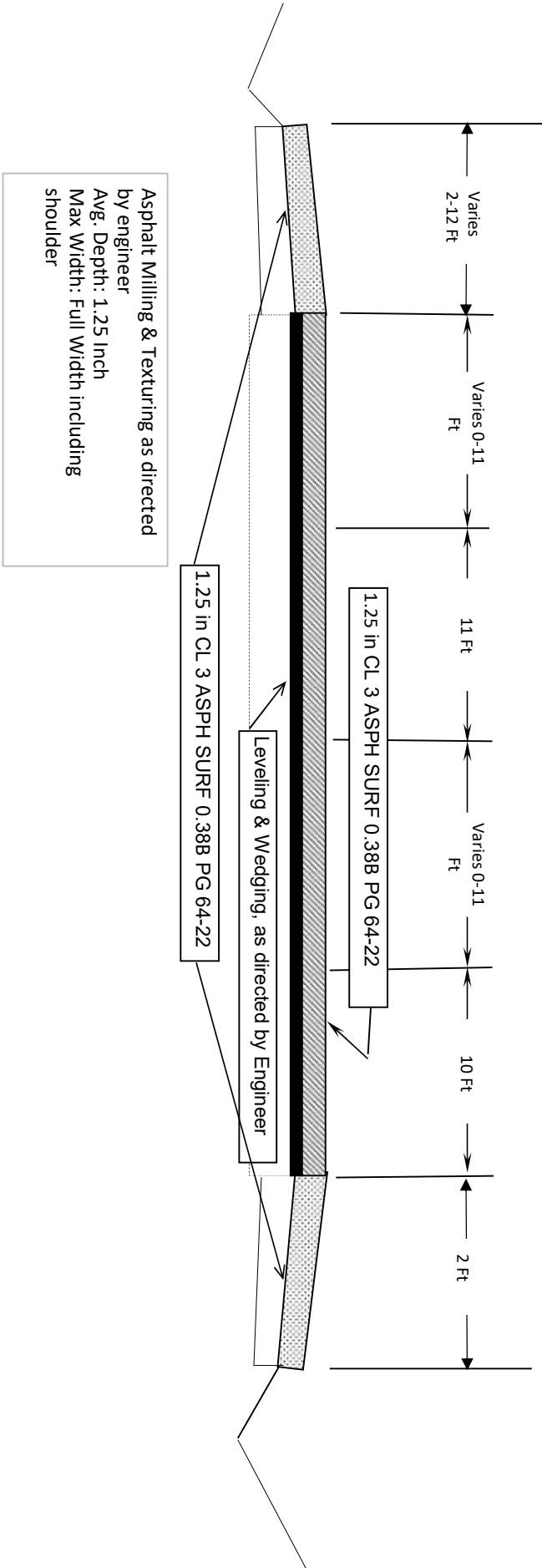

**ADAIR COUNTY**  
**FD05 001 055X 000-001**  
**TYPICAL SECTION**  
**MILEPOINTS 0.090-0.130**

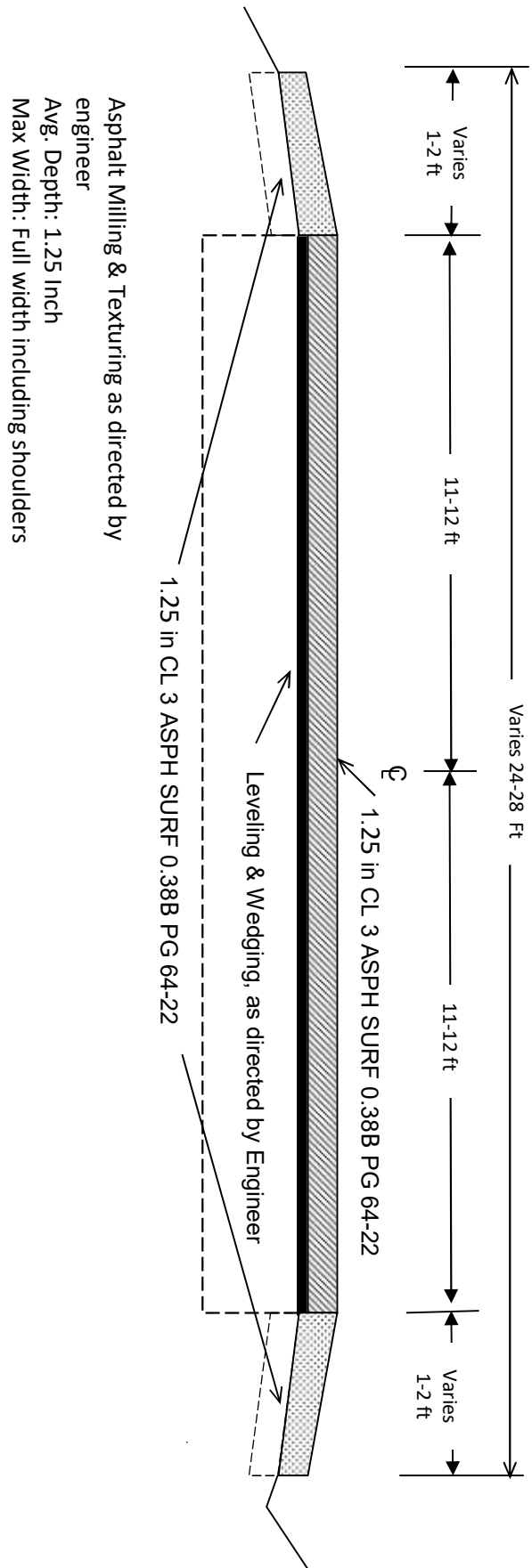

**Adair County**  
**FD05 001 055X 000-001**  
**TYPICAL SECTION**  
**MP 0.130-0.180**

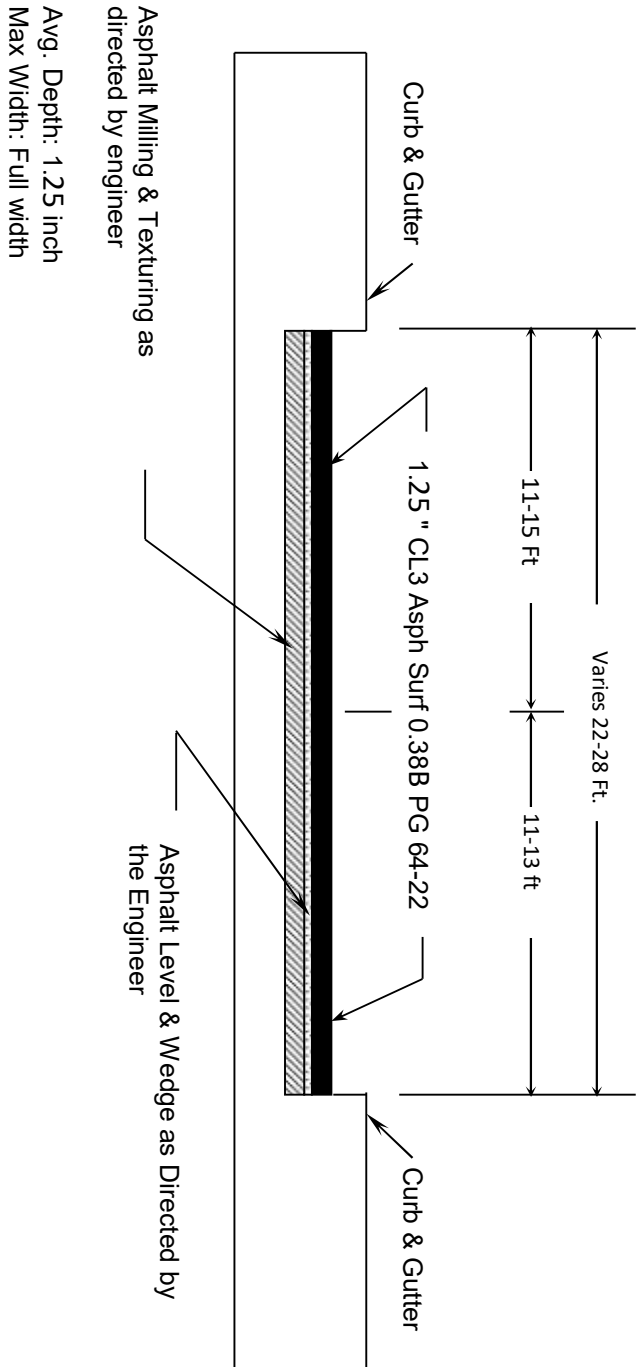

**Adair County**  
**FD05 001 055X 000-001**  
**TYPICAL SECTION**  
**MP 0.180-0.330**

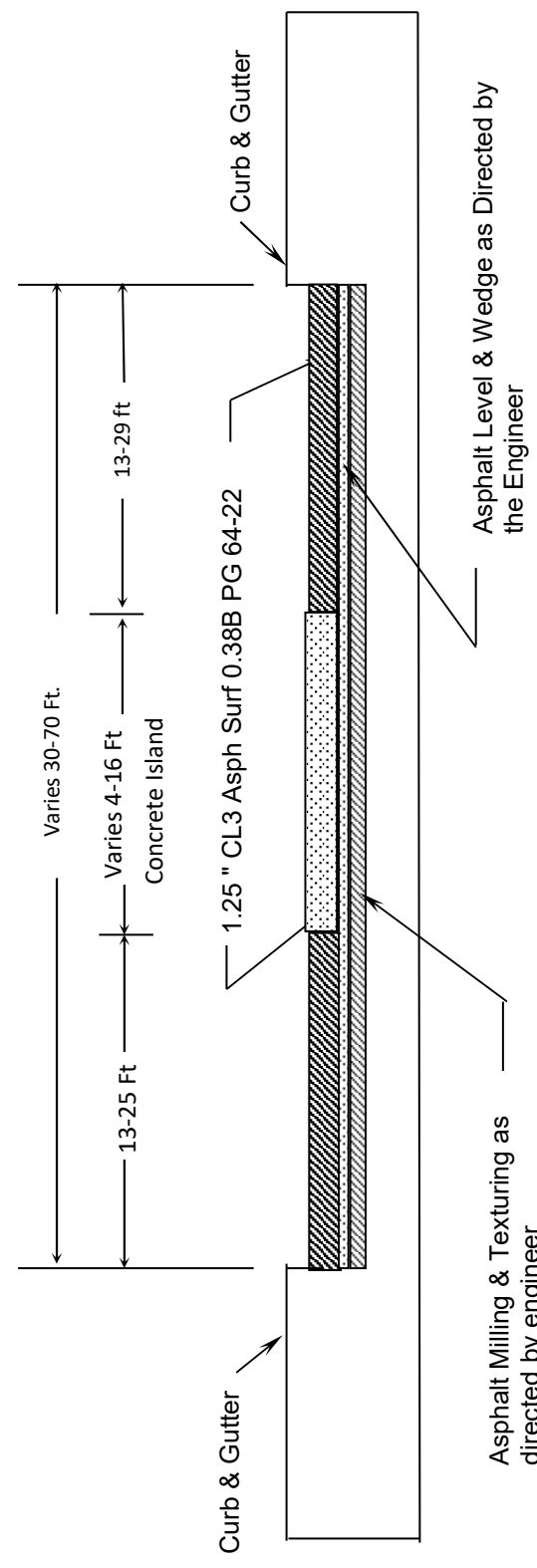

Avg. Depth: 1.25 In  
Max Width: Full width

\*Curb & gutter ends near MP 0.27

**ADAIR COUNTY**  
**FD05 001 055X 000-001**  
**TYPICAL SECTION**  
**MILEPOINTS 0.330-0.391**

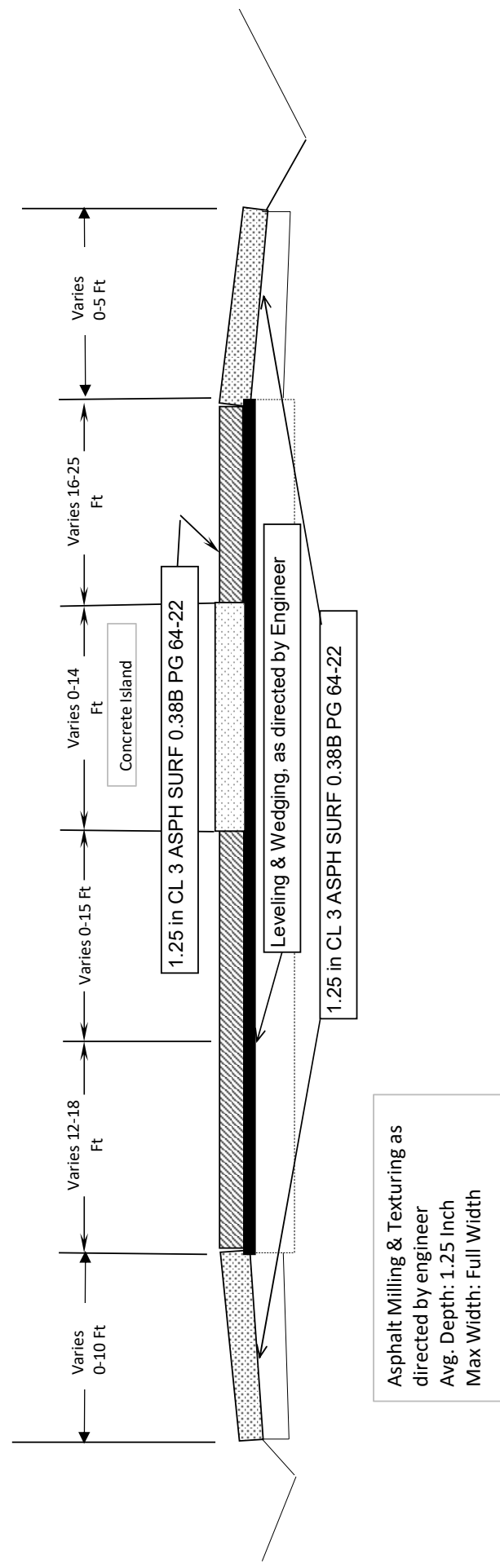



### TYPICAL SECTION

ADAIR COUNTY  
FD05 001 0061 010-013

MP 10.500 TO MP 10.653

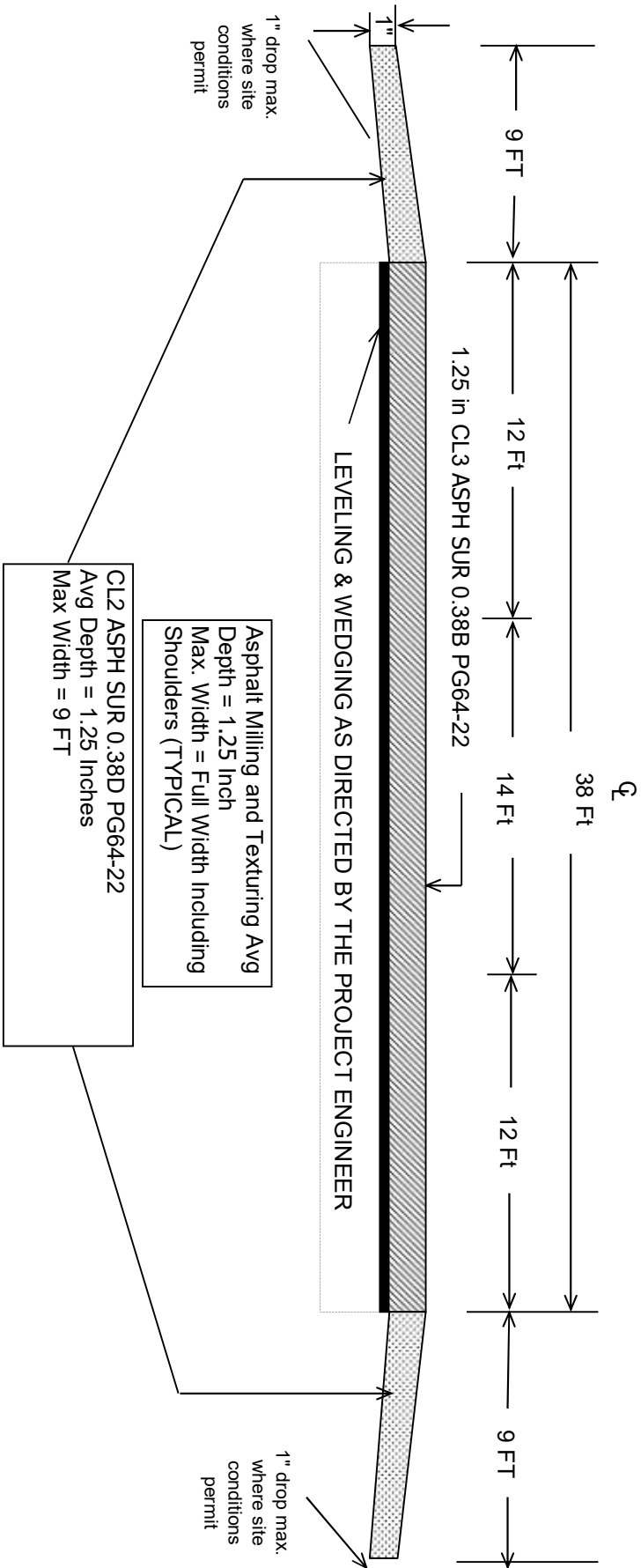

**TYPICAL SECTION**

ADAIR COUNTY

FD05 001 0061 010-013  
MP 10.653 - 10.920

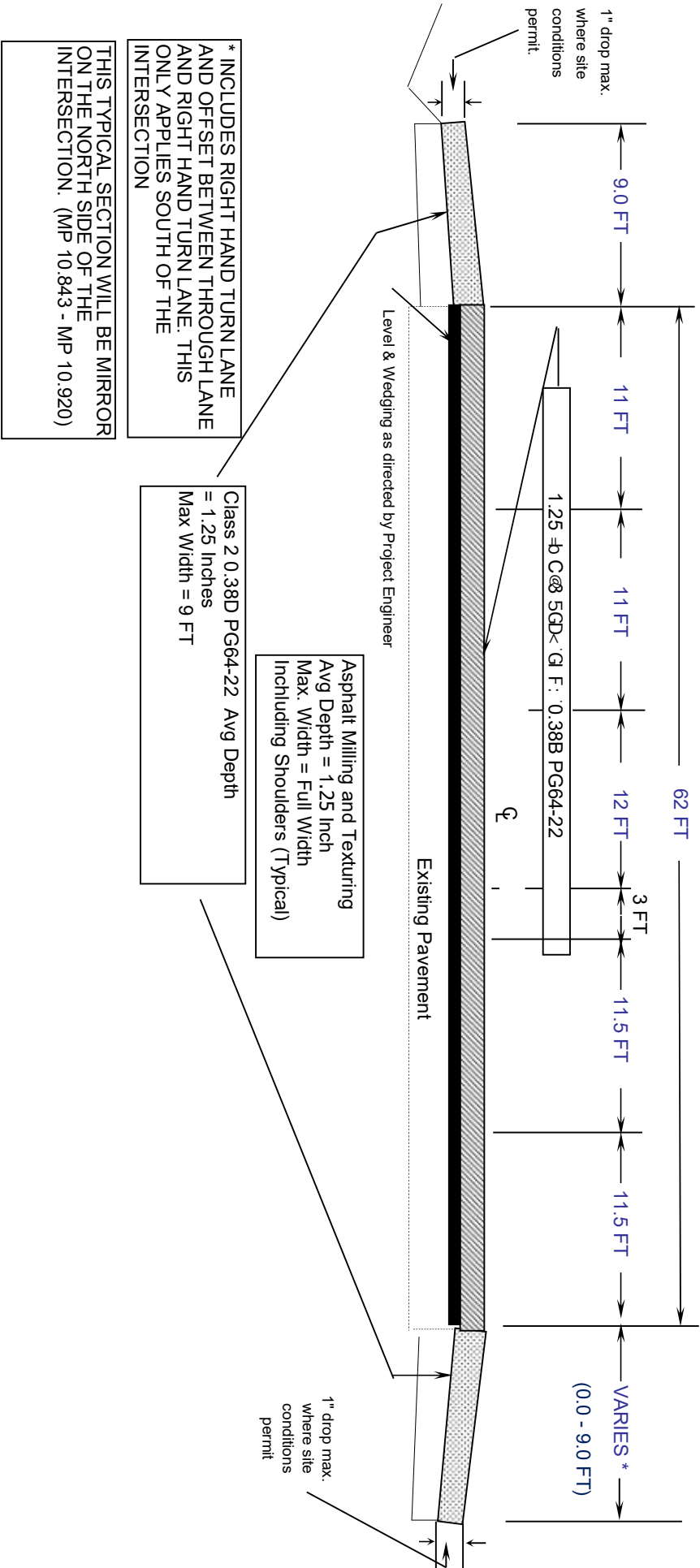

### TYPICAL SECTION

ADAIR COUNTY

FD05 001 0061 010-013  
MP 10.920 -MP 12.100

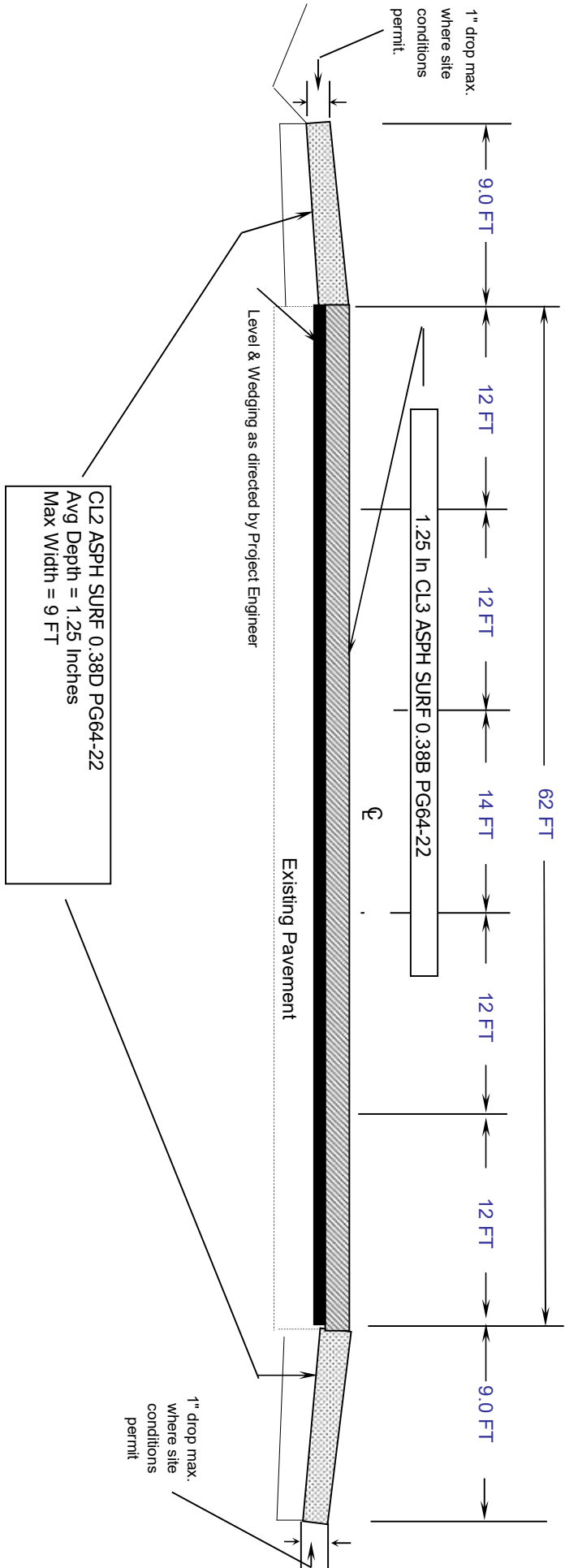

### TYPICAL SECTION

ADAIR COUNTY

FD05 001 0061 010-013  
MP 12.100 - MP 12.213

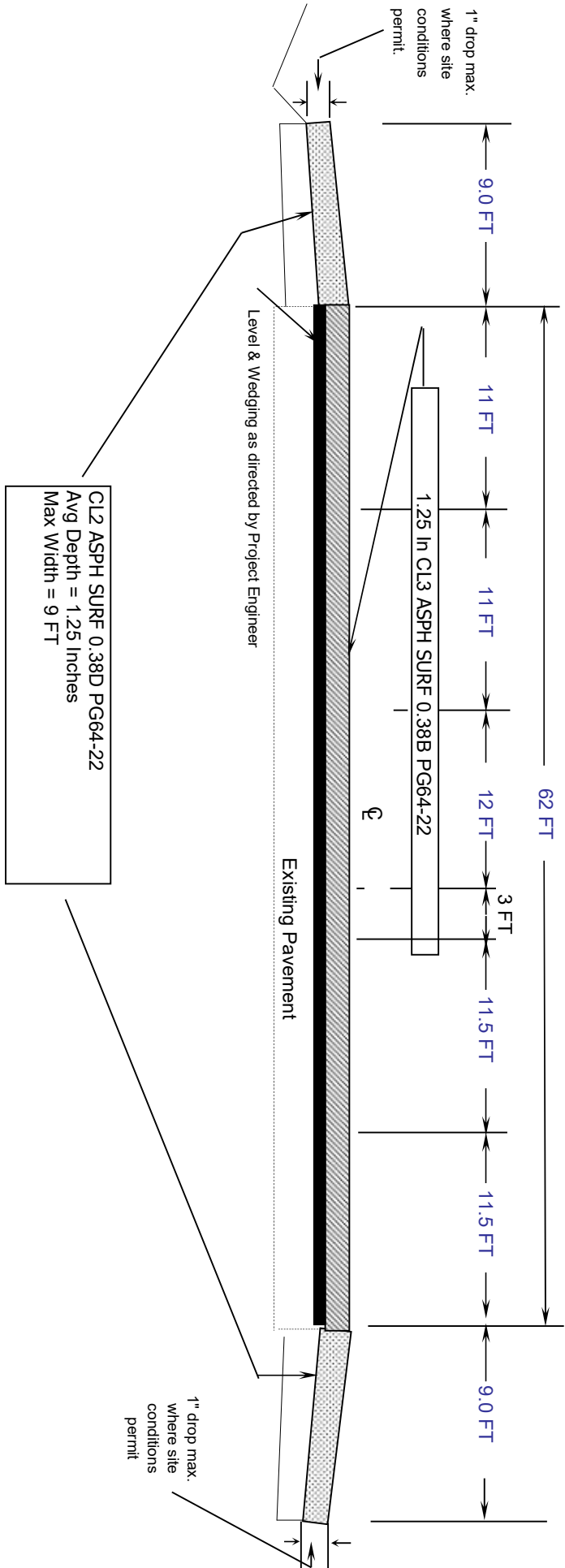

1" drop max.  
where site  
conditions  
permit.

**Adair County  
TYPICAL SECTION  
Fd05 001 0061 017-020  
MP's 17.193 to 19.745**

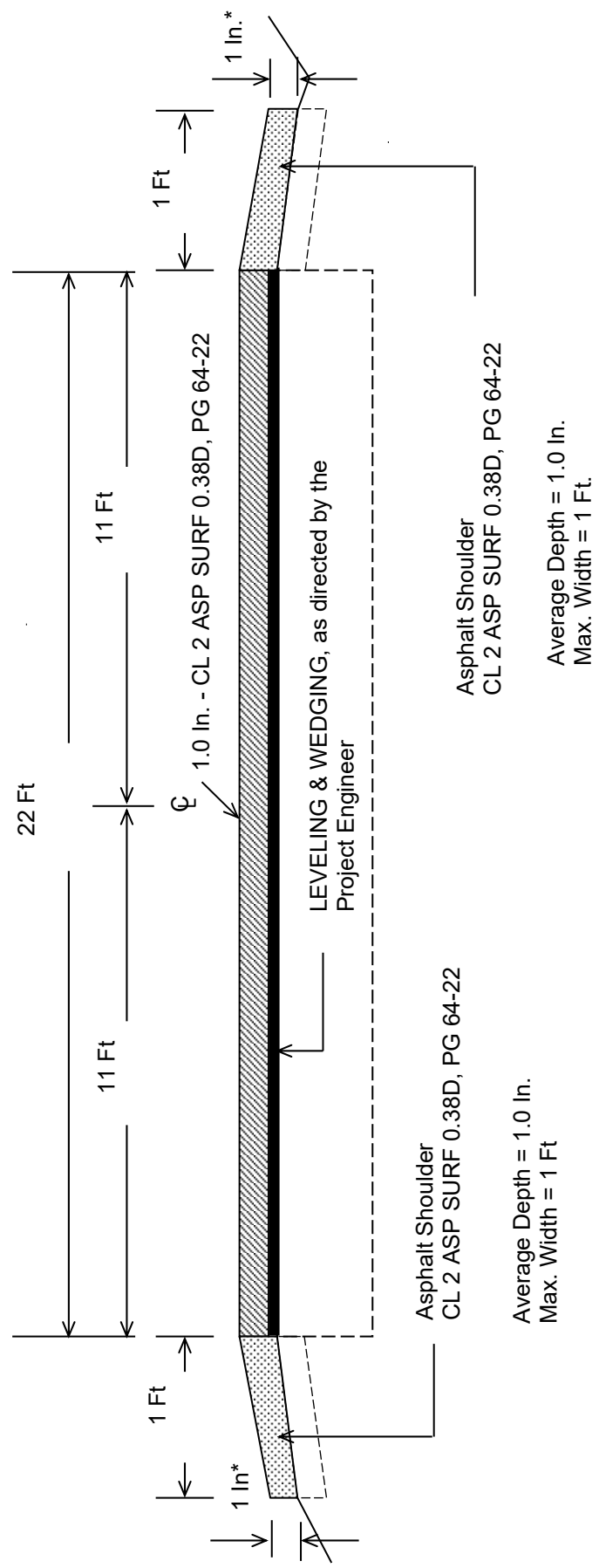

**\*Where Existing Site Conditions Permit**

TSPAVESURFACEshld  
TS1AsphSurfShldr2lane

# TYPICAL SECTIONS

COUNTY OF	ITEM NO.
ADAIR	8-9013.40

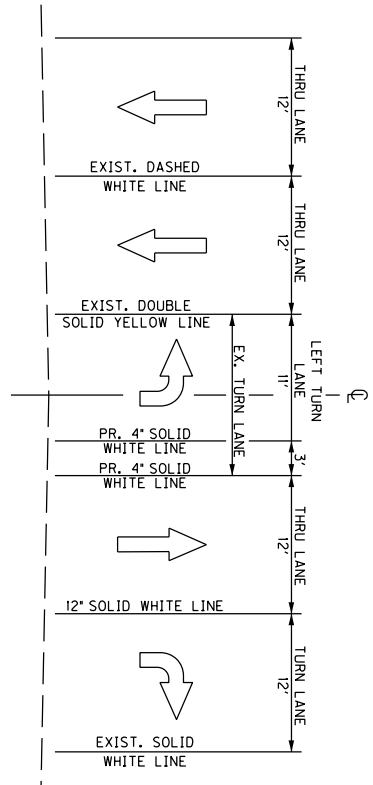

**KY 61 OFFSET LEFT TURN LANE**

STA. 642+68 TO STA. 644+16

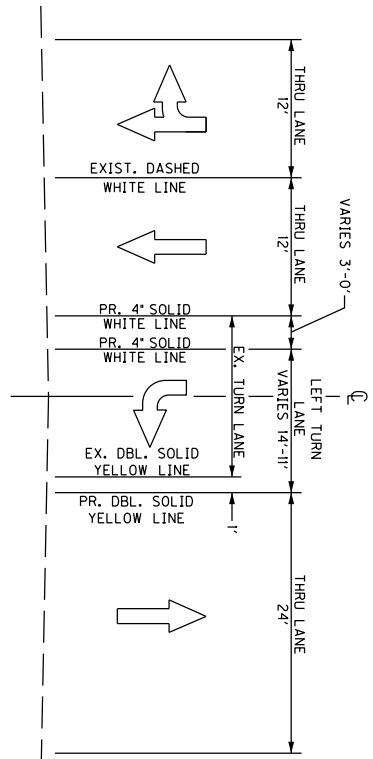

**KY 80 OFFSET LEFT TURN LANE STRIPPING TAPER**

STA. 646+05 TO STA. 648+25

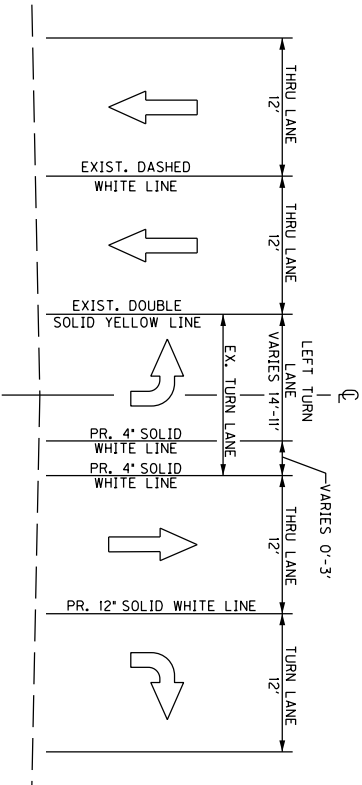

**KY 61 OFFSET LEFT TURN LANE STRIPPING TAPER**

STA. 641+03 TO STA. 642+68

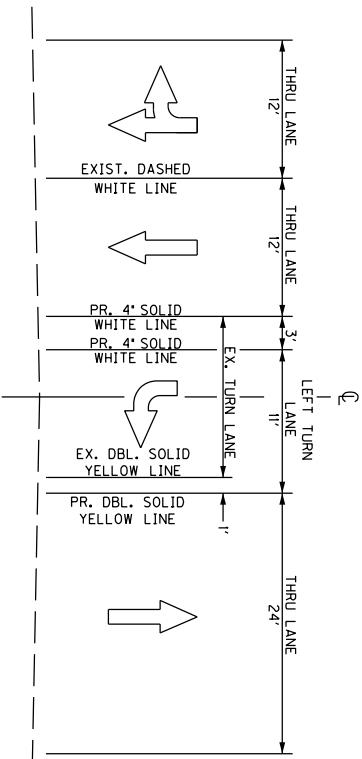

**KY 80 OFFSET LEFT TURN LANE**

STA. 645+10 TO STA. 646+05

KY 55 (MP 10.941) @ KY 61 & KY 80  
TYPICAL SECTIONS

ADAIR COUNTY - KY 55 (MP 10.941) @ KY 61 & KY 80			
ITEM NO. 8-9013.40			
GENERAL SUMMARY			
ITEM	DESCRIPTION	UNIT	QUANTITY
2562	TEMPORARY SIGNS	SQFT	144
2569	DEMOBILIZATION	LS	1
2650	MAINTAIN & CONTROL TRAFFIC (KY 55 @ KY 61 & KY 80)	LS	1
2671	PORTABLE CHANGEABLE MESSAGE SIGN	EACH	2
2726	STAKING (KY 55 @ KY 61 & KY 80)	LS	1
6542	PAVE STRIPING-THERMO-6 IN W	LF	1260
6543	PAVE STRIPING-THERMO-6 IN Y	LF	1712
6546	PAVE STRIPING-THERMO-12 IN W	LF	800
6556	PAVE STRIPING-DUR TY 1-6 IN W	LF	1215
6557	PAVE STRIPING-DUR TY 1-6 IN Y	LF	2160
6568	PAVE MARKING-THERMO STOP BAR-24 IN	LF	80
6569	PAVE MARKING-THERMO CROSS HATCH	SQFT	5478
6573	PAVE MARKING-THERMO STR ARROW	EACH	5
6574	PAVE MARKING-THERMO CURV ARROW	EACH	16
6576	PAVE MARKING-THERMO ONLY	EACH	5
22664EN	WATER BLASTING EXISTING STRIPE	LF	135
23254ES717	PAVE MARK TY 1 TAPE DOTTED LANE EXT (12 IN)	LF	135
24679ED	PAVE MARK THERMO CHEVRON	SQFT	188
24683ED	PAVE MARKING-THERMO DOTTED LANE EXTEN (12 IN)	LF	50

ADAIR COUNTY - KY 55 (MP 10.941) @ KY 61 & KY 80 ITEM NO. 8-9013.40 PAVEMENT MARKING SUMMARY - SHEET 1 OF 2							
KY 61 & KY 80 PAVEMENT MARKINGS							
Begin Station	Begin Offset	End Station	End Offset	Description	Bid Item	Unit	Quantity
628+72.5	18' RT	634+18.4	18' RT	Turn lane marking	PAVE MARK TY 1 TAPE DOTTED LANE EXT	LF	135
634+18.4	18' RT	636+16.0	18' RT	Turn lane marking	PAVE MARKING-THERMO DOTTED LANE EXT	LF	50
637+56	31' LT	644+16	31' LT	Shoulder hatching	PAVE MARKING-THERMO CROSS HATCH	SQFT	440
637+56	31' RT	644+16	31' RT	Shoulder hatching	PAVE MARKING-THERMO CROSS HATCH	SQFT	454
645+09	31' LT	651+69	31' LT	Shoulder hatching	PAVE MARKING-THERMO CROSS HATCH	SQFT	416
645+09	31' RT	651+69	31' RT	Shoulder hatching	PAVE MARKING-THERMO CROSS HATCH	SQFT	416
641+03	7' LT	644+16	7' LT	Offset left turn chevrons	PAVE MARK THERMO CHEVRON	SQFT	80
645+09	7' RT	648+25	7' RT	Offset left turn chevrons	PAVE MARK THERMO CHEVRON	SQFT	108
636+16	25' RT	--	--	Right turn arrow	PAVE MARKING-THERMO CURV ARROW	EACH	1
637+68	25' RT	--	--	Right turn arrow	PAVE MARKING-THERMO CURV ARROW	EACH	1
639+20	25' RT	--	--	Right turn arrow	PAVE MARKING-THERMO CURV ARROW	EACH	1
640+72	25' RT	--	--	Right turn arrow	PAVE MARKING-THERMO CURV ARROW	EACH	1
641+03	0'	--	--	Left turn arrow	PAVE MARKING-THERMO CURV ARROW	EACH	1
641+03	13' RT	--	--	Straight arrow	PAVE MARKING-THERMO STR ARROW	EACH	1
641+71	1' LT	--	--	Left turn arrow	PAVE MARKING-THERMO CURV ARROW	EACH	1
641+71	13' RT	--	--	Straight arrow	PAVE MARKING-THERMO STR ARROW	EACH	1
642+24	25' RT	--	--	Right turn arrow	PAVE MARKING-THERMO CURV ARROW	EACH	1
642+39	1' LT	--	--	Left turn arrow	PAVE MARKING-THERMO CURV ARROW	EACH	1
642+39	13' RT	--	--	Straight arrow	PAVE MARKING-THERMO STR ARROW	EACH	1
643+07	2' LT	--	--	Left turn arrow	PAVE MARKING-THERMO CURV ARROW	EACH	1
643+07	13' RT	--	--	Straight arrow	PAVE MARKING-THERMO STR ARROW	EACH	1
643+76	25' RT	--	--	Right turn arrow	PAVE MARKING-THERMO CURV ARROW	EACH	1
643+76	13' RT	--	--	Straight arrow	PAVE MARKING-THERMO STR ARROW	EACH	1
643+76	2' LT	--	--	Left turn arrow	PAVE MARKING-THERMO CURV ARROW	EACH	1
645+49	1' RT	--	--	Left turn arrow	PAVE MARKING-THERMO CURV ARROW	EACH	1
646+18	1' RT	--	--	Left turn arrow	PAVE MARKING-THERMO CURV ARROW	EACH	1
646+87	0.5' RT	--	--	Left turn arrow	PAVE MARKING-THERMO CURV ARROW	EACH	1
647+56	0.5' RT	--	--	Left turn arrow	PAVE MARKING-THERMO CURV ARROW	EACH	1
648+25	0'	--	--	Left turn arrow	PAVE MARKING-THERMO CURV ARROW	EACH	1
636+92	25' RT	--	--	"ONLY"	PAVE MARKING-THERMO ONLY	EACH	1
638+44	25' RT	--	--	"ONLY"	PAVE MARKING-THERMO ONLY	EACH	1
639+96	25' RT	--	--	"ONLY"	PAVE MARKING-THERMO ONLY	EACH	1
641+48	25' RT	--	--	"ONLY"	PAVE MARKING-THERMO ONLY	EACH	1
643+00	25' RT	--	--	"ONLY"	PAVE MARKING-THERMO ONLY	EACH	1
644+16	7' LT	644+16	31' RT	Stop bar	PAVE MARKING-THERMO STOP BAR-24 IN	LF	38
645+09	34.2' LT	645+09	7.5' RT	Stop bar	PAVE MARKING-THERMO STOP BAR-24 IN	LF	42
KY 55 PAVEMENT MARKINGS							
Begin Station	Begin Offset	End Station	End Offset	Description	Bid Item	Unit	Quantity
570+61	LT	577+21	LT	Shoulder hatching	PAVE MARKING-THERMO CROSS HATCH	SQFT	1064
570+61	RT	577+21	RT	Shoulder hatching	PAVE MARKING-THERMO CROSS HATCH	SQFT	1064
578+18	LT	586+68	LT	Shoulder hatching	PAVE MARKING-THERMO CROSS HATCH	SQFT	812
578+18	RT	586+68	RT	Shoulder hatching	PAVE MARKING-THERMO CROSS HATCH	SQFT	812



ADAIR COUNTY - KY 55 (MP 10.941) @ KY 61 & KY 80 ITEM NO. 8-9013.40 PAVEMENT MARKING SUMMARY - SHEET 2 OF 2							
KY 61 & KY 80 PAVEMENT STRIPING							
Begin Station	Begin Offset	End Station	End Offset	Description	Bid Item	Unit	Quantity
636+16.0	19' RT	644+16.0	19' RT	Wide solid white line	PAVE STRIPING-THERMO-12 IN W	LF	800
628+49	31' LT	633+89	31' LT	Solid white line	PAVE STRIPING-DUR TY 1-6 IN W	LF	540
628+55	19' LT	633+95	19' LT	Dashed white line	PAVE STRIPING-DUR TY 1-6 IN W	LF	135
628+80	31' RT	634+10	31' RT	Solid white line	PAVE STRIPING-DUR TY 1-6 IN W	LF	540
641+03	7' RT	646+16	4' RT	Solid white line	PAVE STRIPING-THERMO-6 IN W	LF	315
641+03.0	7' RT	646+16.0	7' RT	Solid white line	PAVE STRIPING-THERMO-6 IN W	LF	315
645+09	7' LT	648+25	7' LT	Solid white line	PAVE STRIPING-THERMO-6 IN W	LF	315
645+09	3' LT	648+25	7' LT	Solid white line	PAVE STRIPING-THERMO-6 IN W	LF	315
628+61	7' LT	634+01	7' LT	Double solid yellow line	PAVE STRIPING-DUR TY 1-6 IN Y	LF	1080
628+69	7' RT	634+09	7' RT	Double solid yellow line	PAVE STRIPING-DUR TY 1-6 IN Y	LF	1080
639+42.6	7' LT	644+16	7' LT	Double solid yellow line	PAVE STRIPING-THERMO-6 IN Y	LF	944
645+09	8' RT	648+90	7' RT	Double solid yellow line	PAVE STRIPING-THERMO-6 IN Y	LF	768
628+72.5	18' RT	634+18.4	18' RT	Water blast existing stripe	WATER BLASTING EXISTING STRIPE	LF	135

Note: These numbers are for estimate purposes only. Final locations and quantities will be determined by the Engineer in the field.

Item	Description	Unit	Quantity
6542	PAVE STRIPING-THERMO-6 IN W	LF	1260
6543	PAVE STRIPING-THERMO-6 IN Y	LF	1712
6546	PAVE STRIPING-THERMO-12 IN W	LF	800
6556	PAVE STRIPING-DUR TY 1-6 IN W	LF	1215
6557	PAVE STRIPING-DUR TY 1-6 IN Y	LF	2160
6568	PAVE MARKING-THERMO STOP BAR-24 IN	LF	80
6569	PAVE MARKING-THERMO CROSS HATCH	SQFT	5478
6573	PAVE MARKING-THERMO STR ARROW	EACH	5
6574	PAVE MARKING-THERMO CURV ARROW	EACH	16
6576	PAVE MARKING-THERMO ONLY	EACH	5
22664EN	WATER BLASTING EXISTING STRIPE	LF	135
23254ES717	PAVE MARK TY 1 TAPE DOTTED LANE EXT (12 IN)	LF	135
24679ED	PAVE MARK THERMO CHEVRON	SQFT	188
24683ED	PAVE MARKING-THERMO DOTTED LANE EXTEN (12 IN)	LF	50

All quantities carried over to  
General Summary.

STATION	OFFSET	DESCRIPTION
636+16	25' RT	CURV ARROW (RT)
636+92	25' RT	ONLY
637+68	25' RT	CURV ARROW (RT)
638+44	25' RT	ONLY
639+20	25' RT	CURV ARROW (RT)
639+96	25' RT	ONLY
640+72	25' RT	CURV ARROW (RT)
641+03	0'	CURV ARROW (LT)
641+03	13' RT	STR ARROW
641+48	25' RT	ONLY
641+71	1' LT	CURV ARROW (LT)
641+71	13' RT	STR ARROW
642+24	25' RT	CURV ARROW (RT)
642+39	1' LT	CURV ARROW (LT)
642+39	13' RT	STR ARROW
643+00	25' RT	ONLY
643+07	2' LT	CURV ARROW (LT)
643+07	13' RT	STR ARROW
643+76	2' LT	CURV ARROW (LT)
643+76	13' RT	STR ARROW
643+76	25' RT	CURV ARROW (RT)
644+49	1' RT	CURV ARROW (LT)
646+18	1' RT	CURV ARROW (LT)
646+87	0.5' RT	CURV ARROW (LT)
647+56	0.5' RT	CURV ARROW (LT)
648+25	0'	CURV ARROW (LT)

ALL STATIONING BASED ON  
KY 61/KY 80 CENTERLINE

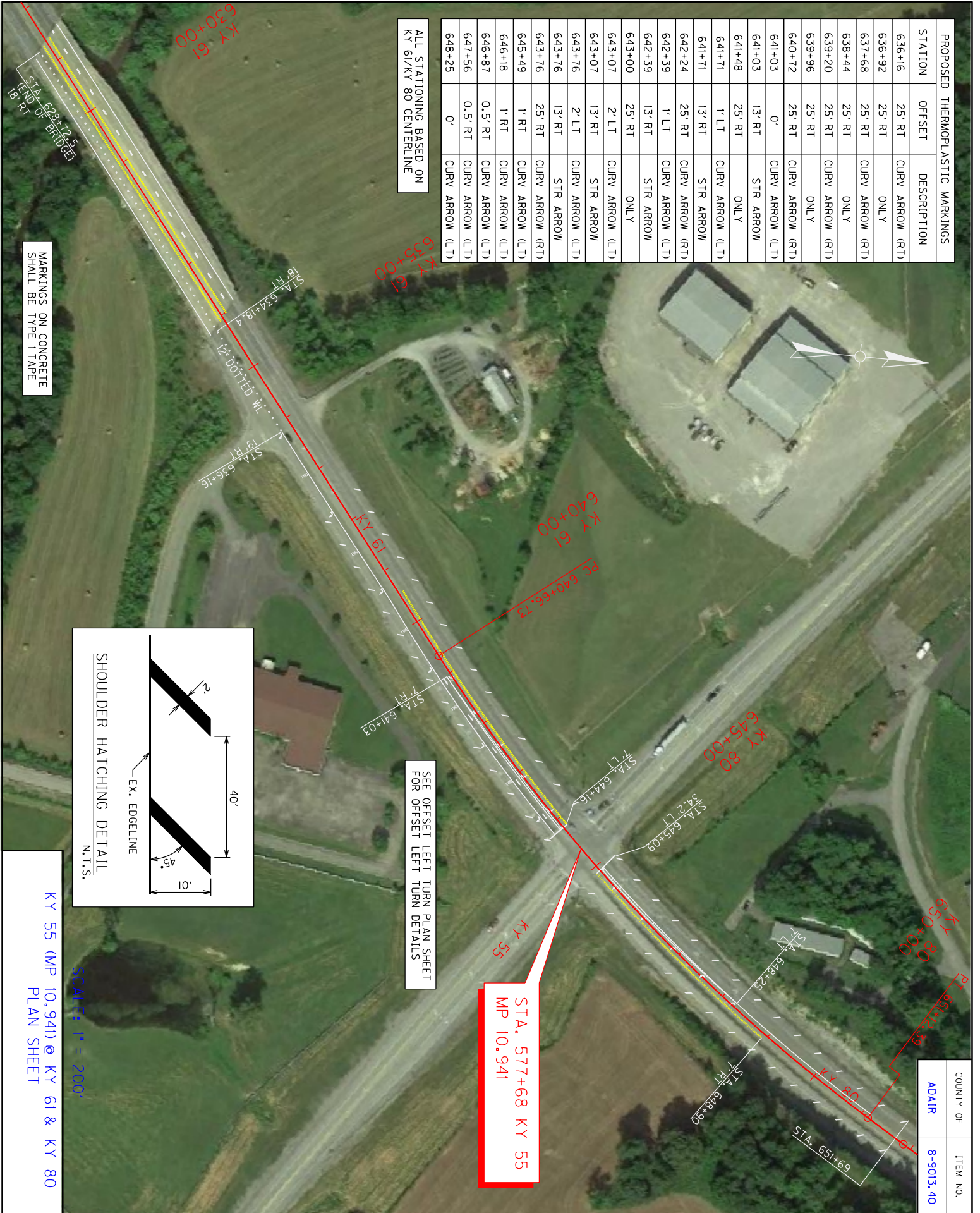

COUNTY OF	ADAIR
ITEM NO.	8-9013.40

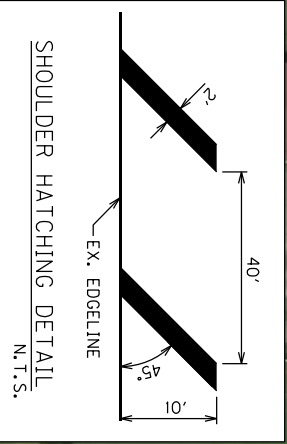

SEE OFFSET LEFT TURN PLAN SHEET  
FOR OFFSET LEFT TURN DETAILS

STA. 577+68 KY 55  
MP 10.941

MARKINGS ON CONCRETE  
SHALL BE TYPE 1 TAPE

KY 55 (MP 10.941) @ KY 61 & KY 80  
PLAN SHEET

SCALE: 1" = 200'

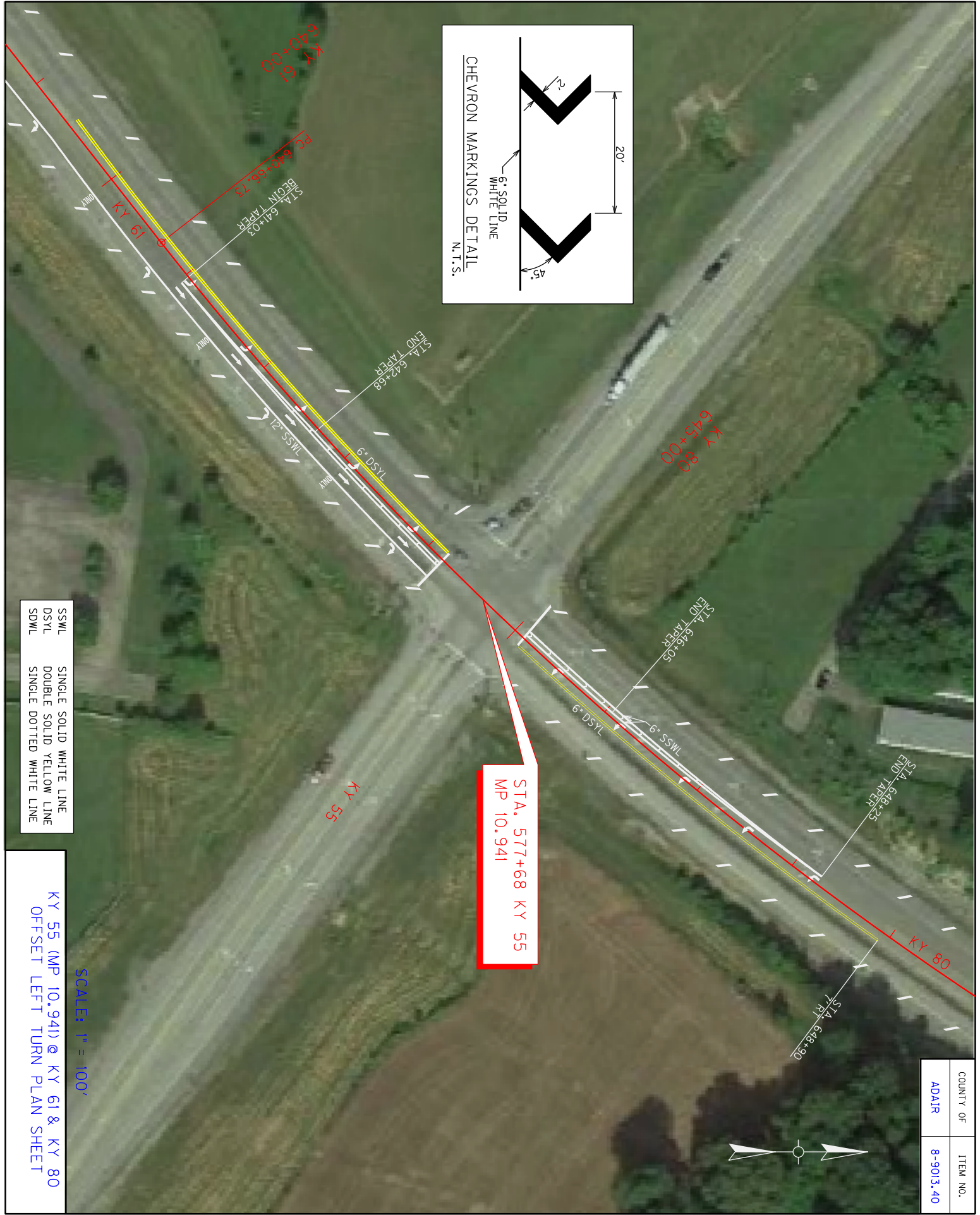

SSWL SINGLE SOLID WHITE LINE  
 DSYL DOUBLE SOLID YELLOW LINE  
 SDWL SINGLE DOTTED WHITE LINE

KY 55 (MP 10.941) @ KY 61 & KY 80  
 OFFSET LEFT TURN PLAN SHEET

SCALE: 1" = 100'

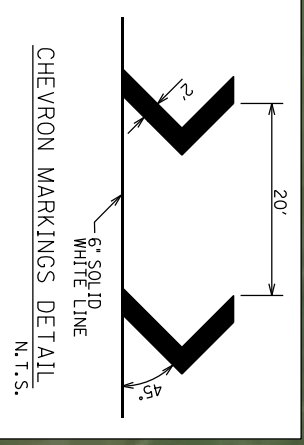

COUNTY OF	ITEM NO.
ADAIR	8-9013.40



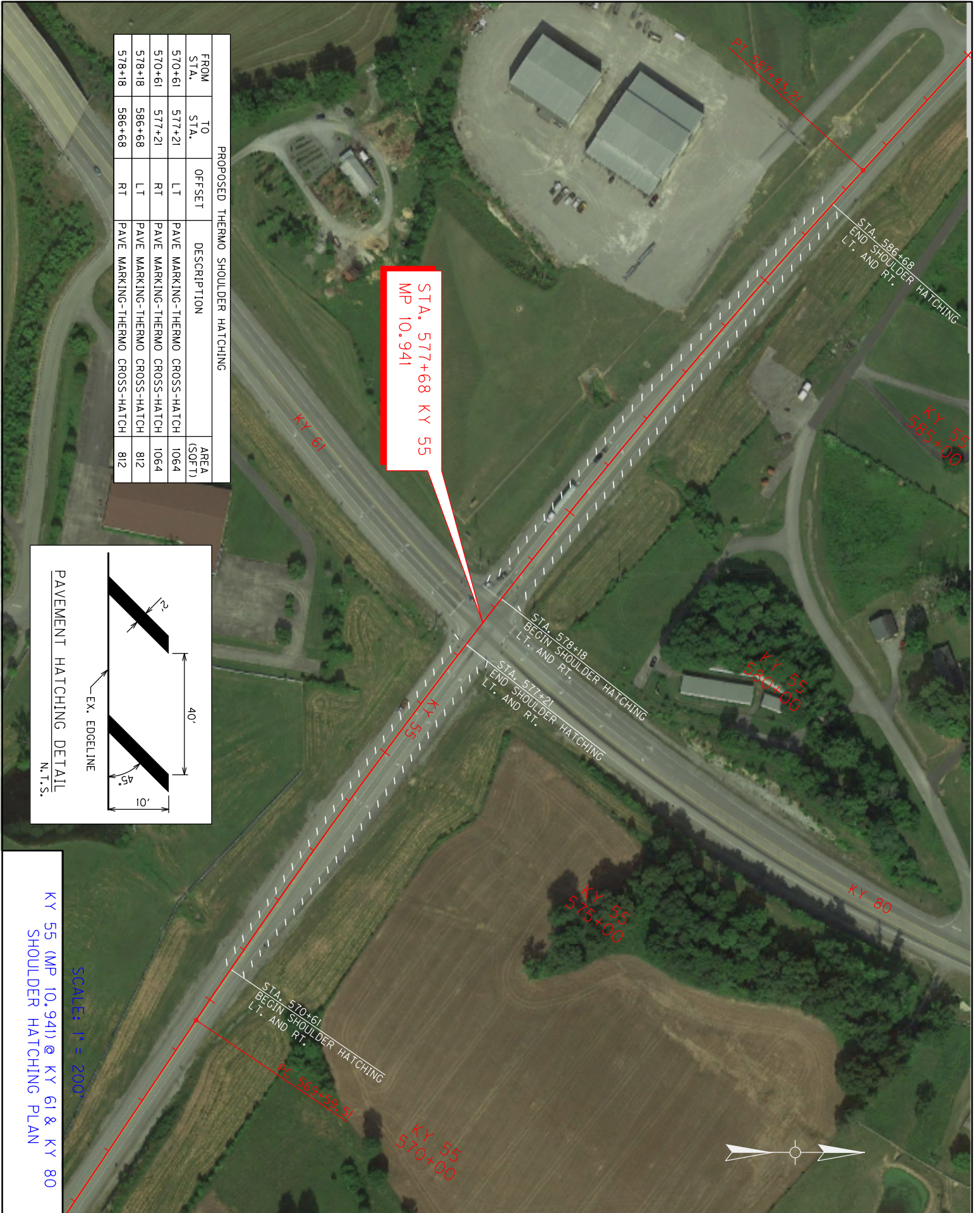

PROPOSED THERMO SHOULDER HATCHING

FROM STA.	TO STA.	OFFSET	DESCRIPTION	AREA (SQ FT)
570+61	577+21	LT	PAVE MARKING-THERMO CROSS-HATCH	1064
570+61	577+21	RT	PAVE MARKING-THERMO CROSS-HATCH	1064
578+18	586+68	LT	PAVE MARKING-THERMO CROSS-HATCH	812
578+18	586+68	RT	PAVE MARKING-THERMO CROSS-HATCH	812

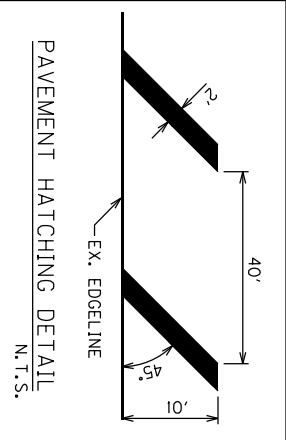

SCALE: 1" = 200'  
KY 55 (MP 10.941) @ KY 61 & KY 80  
SHOULDER HATCHING PLAN

**CONSTRUCTION DETAIL FOR BRIDGE WITHIN LIMITS OF  
PAVING PROJECT  
KY 55X AND KY 61 IN ADAIR COUNTY**

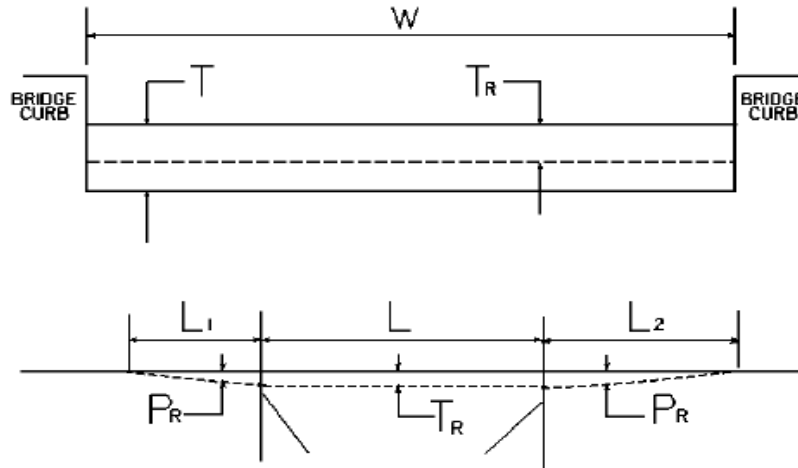

W = bridge width curb to curb                      T = thickness of existing bituminous overlay                      L = length of bridge  
 L<sub>1</sub> & L<sub>2</sub> = length of approach pavement to be removed  
 T<sub>R</sub> = thickness to be removed and replaced on bridge                      P<sub>R</sub> = thickness to be removed and replaced on pavement  
**Note:** L<sub>1</sub> & L<sub>2</sub> lengths shall be determined by using a transition rate of 100 ft / inch of thickness

BRIDGE NO	MP	W (ft)	T (in)	L <sub>1</sub> (ft)	L <sub>2</sub> (ft)	T <sub>R</sub> (in)	L (ft)	P <sub>R</sub> (in)
B00059N	0.406	50.00	0.00	100.00	0.00	0.00	198.00	1.00
B00083N	10.632	62.00	0.00	100.00	100.00	0.00	222.00	1.25
B00082N	11.946	82.00	0.00	125.00	125.00	0.00	549.00	1.25

**PART II**  
**SPECIFICATIONS AND STANDARD DRAWINGS**

### **SPECIFICATIONS REFERENCE**

Any reference in the plans or proposal to previous editions of the *Standard Specifications for Road and Bridge Construction* and *Standard Drawings* are superseded by *Standard Specifications for Road and Bridge Construction, Edition of 2019* and *Standard Drawings, Edition of 2020*.

## **SUPPLEMENTAL SPECIFICATIONS**

The contractor shall use the Supplemental Specifications that are effective at the time of letting.  
The Supplemental Specifications can be found at the following link:

<http://transportation.ky.gov/Construction/Pages/Kentucky-Standard-Specifications.aspx>



### **SPECIAL NOTE FOR PORTABLE CHANGEABLE MESSAGE SIGNS**

This Special Note will apply when indicated on the plans or in the proposal.

**1.0 DESCRIPTION.** Furnish, install, operate, and maintain variable message signs at the locations shown on the plans or designated by the Engineer. Remove and retain possession of variable message signs when they are no longer needed on the project.

#### **2.0 MATERIALS.**

**2.1 General.** Use LED Variable Message Signs Class I, II, or III, as appropriate, from the Department's List of Approved Materials.

Unclassified signs may be submitted for approval by the Engineer. The Engineer may require a daytime and nighttime demonstration. The Engineer will make a final decision within 30 days after all required information is received.

**2.2 Sign and Controls.** All signs must:

- 1) Provide 3-line messages with each line being 8 characters long and at least 18 inches tall. Each character comprises 35 pixels.
- 2) Provide at least 40 preprogrammed messages available for use at any time. Provide for quick and easy change of the displayed message; editing of the message; and additions of new messages.
- 3) Provide a controller consisting of:
  - a) Keyboard or keypad.
  - b) Readout that mimics the actual sign display. (When LCD or LCD type readout is used, include backlighting and heating or otherwise arrange for viewing in cold temperatures.)
  - c) Non-volatile memory or suitable memory with battery backup for storing pre-programmed messages.
  - d) Logic circuitry to control the sequence of messages and flash rate.
- 4) Provide a serial interface that is capable of supporting complete remote control ability through land line and cellular telephone operation. Include communication software capable of immediately updating the message, providing complete sign status, and allowing message library queries and updates.
- 5) Allow a single person easily to raise the sign to a satisfactory height above the pavement during use, and lower the sign during travel.
- 6) Be Highway Orange on all exterior surfaces of the trailer, supports, and controller cabinet.
- 7) Provide operation in ambient temperatures from -30 to + 120 degrees Fahrenheit during snow, rain and other inclement weather.
- 8) Provide the driver board as part of a module. All modules are interchangeable, and have plug and socket arrangements for disconnection and reconnection. Printed circuit boards associated with driver boards have a conformable coating to protect against moisture.
- 9) Provide a sign case sealed against rain, snow, dust, insects, etc. The lens is UV stabilized clear plastic (polycarbonate, acrylic, or other approved material) angled to prevent glare.
- 10) Provide a flat black UV protected coating on the sign hardware, character PCB, and appropriate lens areas.
- 11) Provide a photocell control to provide automatic dimming.

- 12) Allow an on-off flashing sequence at an adjustable rate.
- 13) Provide a sight to aim the message.
- 14) Provide a LED display color of approximately 590 nm amber.
- 15) Provide a controller that is password protected.
- 16) Provide a security device that prevents unauthorized individuals from accessing the controller.
- 17) Provide the following 3-line messages preprogrammed and available for use when the sign unit begins operation:

/KEEP/RIGHT/=>=>=>/	/MIN/SPEED/**MPH/
/KEEP/LEFT/<=<=</	/ICY/BRIDGE/AHEAD/ /ONE
/LOOSE/GRAVEL/AHEAD/	LANE/BRIDGE/AHEAD/
/RD WORK/NEXT/**MILES/	/ROUGH/ROAD/AHEAD/
/TWO WAY/TRAFFIC/AHEAD/	/MERGING/TRAFFIC/AHEAD/
/PAINT/CREW/AHEAD/	/NEXT/***/MILES/
/REDUCE/SPEED/**MPH/	/HEAVY/TRAFFIC/AHEAD/
/BRIDGE/WORK/***0 FT/	/SPEED/LIMIT/**MPH/
/MAX/SPEED/**MPH/	/BUMP/AHEAD/
/SURVEY/PARTY/AHEAD/	/TWO/WAY/TRAFFIC/

\*Insert numerals as directed by the Engineer.  
Add other messages during the project when required by the Engineer.

**2.3 Power.**

- 1) Design solar panels to yield 10 percent or greater additional charge than sign consumption. Provide direct wiring for operation of the sign or arrow board from an external power source to provide energy backup for 21 days without sunlight and an on-board system charger with the ability to recharge completely discharged batteries in 24 hours.

**3.0 CONSTRUCTION.** Furnish and operate the variable message signs as designated on the plans or by the Engineer. Ensure the bottom of the message panel is a minimum of 7 feet above the roadway in urban areas and 5 feet above in rural areas when operating. Use Class I, II, or III signs on roads with a speed limit less than 55 mph. Use Class I or II signs on roads with speed limits 55 mph or greater.

Maintain the sign in proper working order, including repair of any damage done by others, until completion of the project. When the sign becomes inoperative, immediately repair or replace the sign. Repetitive problems with the same unit will be cause for rejection and replacement.

Use only project related messages and messages directed by the Engineer, unnecessary messages lessen the impact of the sign. Ensure the message is displayed in either one or 2 phases with each phase having no more than 3 lines of text. When no message is needed, but it is necessary to know if the sign is operable, flash only a pixel.

When the sign is not needed, move it outside the clear zone or where the Engineer directs. Variable Message Signs are the property of the Contractor and shall be removed from the project when no longer needed. The Department will not assume ownership of these signs.

**4.0 MEASUREMENT.** The final quantity of Variable Message Sign will be

11

the actual number of individual signs acceptably furnished and operated during the project. The Department will not measure signs replaced due to damage or rejection.

**5.0 PAYMENT.** The Department will pay for the Variable Message Signs at the unit price each. The Department will not pay for signs replaced due to damage or rejection. Payment is full compensation for furnishing all materials, labor, equipment, and service necessary to, operate, move, repair, and maintain or replace the variable message signs. The Department will make payment for the completed and accepted quantities under the following:

<u>Code</u>	<u>Pay Item</u>	<u>Pay Unit</u>
02671	Portable Changeable Message Sign	Each

Effective June 15, 2012

## 2020 KENTUCKY STANDARD DRAWINGS

---

MISCELLANEOUS STANDARDS.....	RGX-001-06
APPROACHES, ENTRANCES, AND MAIL BOX TURNOUT .....	RPM-110-07
PAVEMENT STRIPING DETAILS FOR TWO LANE TWO WAY ROADWAYS .....	TPM-175
CENTERLINE RUMBLE STRIPS PLACEMENT DETAILS .....	TPR-100
CENTERLINE RUMBLE STRIPS 6 INCH STRIPING .....	TPR-110
SHOULDER & EDGELINE RUMBLE STRIPS PLACEMENT DETAILS .....	TPR-115
EDGELINE RUMBLE STRIP DETAILS TWO LANE ROADWAYS .....	TPR-120
SHOULDER RUMBLE STRIP DETAILS TWO LANE ROADWAYS .....	TPR-125
LANE CLOSURE TWO-LANE HIGHWAY .....	TTC-100-05
LANE CLOSURE MULTI-LANE HIGHWAY CASE I.....	TTC-115-04
LANE CLOSURE MULTI-LANE HIGHWAY CASE II .....	TTC-120-04
SHOULDER CLOSURE .....	TTC-135-03
PAVEMENT CONDITION WARNING SIGNS.....	TTD-125-06
MOBILE OPERATION FOR PAINT STRIPING CASE I .....	TTS-100-02
MOBILE OPERATION FOR PAINT STRIPING CASE II.....	TTS-105-02
MOBILE OPERATION FOR DURABLE STRIPING CASE III.....	TTS-130-02
MOBILE OPERATION FOR DURABLE STRIPING CASE IV .....	TTS-135-02

**PART III**

**EMPLOYMENT, WAGE AND RECORD REQUIREMENTS**

**TRANSPORTATION CABINET  
DEPARTMENT OF HIGHWAYS**

**LABOR AND WAGE REQUIREMENTS  
APPLICABLE TO OTHER THAN FEDERAL-AID SYSTEM PROJECTS**

- I. Application
- II. Nondiscrimination of Employees (KRS 344)

**I. APPLICATION**

1. These contract provisions shall apply to all work performed on the contract by the contractor with his own organization and with the assistance of workmen under his immediate superintendence and to all work performed on the contract by piecework, station work or by subcontract. The contractor's organization shall be construed to include only workmen employed and paid directly by the contractor and equipment owned or rented by him, with or without operators.

2. The contractor shall insert in each of his subcontracts all of the stipulations contained in these Required Provisions and such other stipulations as may be required.

3. A breach of any of the stipulations contained in these Required Provisions may be grounds for termination of the contract.

3. If the contractor is in control of apprenticeship or other training or retraining, including on-the-job training programs, he shall not discriminate against an individual because of his race, color, religion, national origin, sex, disability or age forty (40) and over, in admission to, or employment in any program established to provide apprenticeship or other training.

4. The contractor will send to each labor union or representative of workers with which he has a collective bargaining agreement or other contract or understanding, a notice to be provided advising the said labor union or workers' representative of the contractor's commitments under this section, and shall post copies of the notice in conspicuous places available to employees and applicants for employment. The contractor will take such action with respect to any subcontract or purchase order as the administrating agency may direct as a means of enforcing such provisions, including sanctions for non-compliance.

Revised: January 25, 2017

**II. NONDISCRIMINATION OF EMPLOYEES**

**AN ACT OF THE KENTUCKY  
GENERAL ASSEMBLY TO PREVENT  
DISCRIMINATION IN EMPLOYMENT  
KRS CHAPTER 344  
EFFECTIVE JUNE 16, 1972**

The contract on this project, in accordance with KRS Chapter 344, provides that during the performance of this contract, the contractor agrees as follows:

1. The contractor shall not fail or refuse to hire, or shall not discharge any individual, or otherwise discriminate against an individual with respect to his compensation, terms, conditions, or privileges of employment, because of such individual's race, color, religion, national origin, sex, disability or age (forty and above); or limit, segregate, or classify his employees in any way which would deprive or tend to deprive an individual of employment opportunities or otherwise adversely affect his status as an employee, because of such individual's race, color, religion, national origin, sex, disability or age forty (40) and over. The contractor agrees to post in conspicuous places, available to employees and applicants for employment, notices to be provided setting forth the provisions of this nondiscrimination clause.

2. The contractor shall not print or publish or cause to be printed or published a notice or advertisement relating to employment by such an employer or membership in or any classification or referral for employment by the employment agency, indicating any preference, limitation, specification, or discrimination, based on race, color, religion, national origin, sex, or age forty (40) and over, or because the person is a qualified individual with a disability, except that such a notice or advertisement may indicate a preference, limitation, or specification based on religion, national origin, sex, or age forty (40) and over, or because the person is a qualified individual with a disability, when religion, national origin, sex, or age forty (40) and over, or because the person is a qualified individual with a disability, is a bona fide occupational qualification for employment.

## EXECUTIVE BRANCH CODE OF ETHICS

In the 1992 regular legislative session, the General Assembly passed and Governor Brereton Jones signed Senate Bill 63 (codified as KRS 11A), the Executive Branch Code of Ethics, which states, in part:

KRS 11A.040 (7) provides:

No present or former public servant shall, within six (6) months following termination of his office or employment, accept employment, compensation, or other economic benefit from any person or business that contracts or does business with, or is regulated by, the state in matters in which he was directly involved during the last thirty-six (36) months of his tenure. This provision shall not prohibit an individual from returning to the same business, firm, occupation, or profession in which he was involved prior to taking office or beginning his term of employment, or for which he received, prior to his state employment, a professional degree or license, provided that, for a period of six (6) months, he personally refrains from working on any matter in which he was directly involved during the last thirty-six (36) months of his tenure in state government. This subsection shall not prohibit the performance of ministerial functions, including but not limited to filing tax returns, filing applications for permits or licenses, or filing incorporation papers, nor shall it prohibit the former officer or public servant from receiving public funds disbursed through entitlement programs.

KRS 11A.040 (9) states:

A former public servant shall not represent a person or business before a state agency in a matter in which the former public servant was directly involved during the last thirty-six (36) months of his tenure, for a period of one (1) year after the latter of:

- a) The date of leaving office or termination of employment; or
- b) The date the term of office expires to which the public servant was elected.

This law is intended to promote public confidence in the integrity of state government and to declare as public policy the idea that state employees should view their work as a public trust and not as a way to obtain private benefits.

If you have worked for the executive branch of state government within the past six months, you may be subject to the law's prohibitions. The law's applicability may be different if you hold elected office or are contemplating representation of another before a state agency.

Also, if you are affiliated with a firm which does business with the state and which employs former state executive-branch employees, you should be aware that the law may apply to them.

In case of doubt, the law permits you to request an advisory opinion from the Executive Branch Ethics Commission, 3 Fountain Place, Frankfort, Kentucky 40601; telephone (502) 564-7954.

### **Kentucky Equal Employment Opportunity Act of 1978**

The requirements of the Kentucky Equal Employment Opportunity Act of 1978 (KRS 45.560-45.640) shall apply to this Contract. The apparent low Bidder will be required to submit EEO forms to the Division of Construction Procurement, which will then forward to the Finance and Administration Cabinet for review and approval. No award will become effective until all forms are submitted and EEO/CC has certified compliance. The required EEO forms are as follows:

- EEO-1: Employer Information Report
- Affidavit of Intent to Comply
- Employee Data Sheet
- Subcontractor Report

These forms are available on the Finance and Administration's web page under ***Vendor Information, Standard Attachments and General Terms*** at the following address:  
**<https://www.eProcurement.ky.gov>**.

Bidders currently certified as being in compliance by the Finance and Administration Cabinet may submit a copy of their approval letter in lieu of the referenced EEO forms.

For questions or assistance please contact the Finance and Administration Cabinet by email at **[finance.contractcompliance@ky.gov](mailto:finance.contractcompliance@ky.gov)** or by phone at 502-564-2874.



# EMPLOYEE RIGHTS UNDER THE FAIR LABOR STANDARDS ACT

THE UNITED STATES DEPARTMENT OF LABOR WAGE AND HOUR DIVISION

## FEDERAL MINIMUM WAGE

# \$7.25 PER HOUR

BEGINNING JULY 24, 2009

**OVERTIME PAY** At least 1½ times your regular rate of pay for all hours worked over 40 in a workweek.

**CHILD LABOR** An employee must be at least **16** years old to work in most non-farm jobs and at least **18** to work in non-farm jobs declared hazardous by the Secretary of Labor.

Youths **14** and **15** years old may work outside school hours in various non-manufacturing, non-mining, non-hazardous jobs under the following conditions:

**No more than**

- **3** hours on a school day or **18** hours in a school week;
- **8** hours on a non-school day or **40** hours in a non-school week.

Also, work may not begin before **7 a.m.** or end after **7 p.m.**, except from June 1 through Labor Day, when evening hours are extended to **9 p.m.** Different rules apply in agricultural employment.

**TIP CREDIT** Employers of “tipped employees” must pay a cash wage of at least \$2.13 per hour if they claim a tip credit against their minimum wage obligation. If an employee’s tips combined with the employer’s cash wage of at least \$2.13 per hour do not equal the minimum hourly wage, the employer must make up the difference. Certain other conditions must also be met.

**ENFORCEMENT** The Department of Labor may recover back wages either administratively or through court action, for the employees that have been underpaid in violation of the law. Violations may result in civil or criminal action.

Employers may be assessed civil money penalties of up to \$1,100 for each willful or repeated violation of the minimum wage or overtime pay provisions of the law and up to \$11,000 for each employee who is the subject of a violation of the Act’s child labor provisions. In addition, a civil money penalty of up to \$50,000 may be assessed for each child labor violation that causes the death or serious injury of any minor employee, and such assessments may be doubled, up to \$100,000, when the violations are determined to be willful or repeated. The law also prohibits discriminating against or discharging workers who file a complaint or participate in any proceeding under the Act.

### ADDITIONAL INFORMATION

- Certain occupations and establishments are exempt from the minimum wage and/or overtime pay provisions.
- Special provisions apply to workers in American Samoa and the Commonwealth of the Northern Mariana Islands.
- Some state laws provide greater employee protections; employers must comply with both.
- The law requires employers to display this poster where employees can readily see it.
- Employees under 20 years of age may be paid \$4.25 per hour during their first 90 consecutive calendar days of employment with an employer.
- Certain full-time students, student learners, apprentices, and workers with disabilities may be paid less than the minimum wage under special certificates issued by the Department of Labor.

For additional information:



# 1-866-4-USWAGE

(1-866-487-9243)

TTY: 1-877-889-5627



# WWW.WAGEHOUR.DOL.GOV

**PART IV**  
**INSURANCE**

Refer to  
*Kentucky Standard Specifications for Road and Bridge Construction,*  
current edition

**PART V**  
**BID ITEMS**

**PROPOSAL BID ITEMS**

222287

Page 1 of 2

Report Date 4/21/22

**Section: 0001 - ROADWAY**

LINE	BID CODE	ALT	DESCRIPTION	QUANTITY	UNIT	UNIT PRIC	FP	AMOUNT
0010	00190		LEVELING & WEDGING PG64-22	845.00	TON		\$	
0020	00301		CL2 ASPH SURF 0.38D PG64-22	3,590.00	TON		\$	
0030	00356		ASPHALT MATERIAL FOR TACK	66.00	TON		\$	
0040	00388		CL3 ASPH SURF 0.38B PG64-22	5,335.00	TON		\$	
0050	02562		TEMPORARY SIGNS	890.00	SQFT		\$	
0060	02585		EDGE KEY	400.00	LF		\$	
0070	02650		MAINTAIN & CONTROL TRAFFIC (KY 55X)	1.00	LS		\$	
0080	02650		MAINTAIN & CONTROL TRAFFIC (KY 61, MP 10-13)	1.00	LS		\$	
0090	02650		MAINTAIN & CONTROL TRAFFIC (KY 61, MP 17-20)	1.00	LS		\$	
0100	02671		PORTABLE CHANGEABLE MESSAGE SIGN	2.00	EACH		\$	
0110	02676		MOBILIZATION FOR MILL & TEXT (KY 55X)	1.00	LS		\$	
0120	02676		MOBILIZATION FOR MILL & TEXT (KY 61, MP 10-13)	1.00	LS		\$	
0130	02677		ASPHALT PAVE MILLING & TEXTURING	2,185.00	TON		\$	
0140	02696		SHOULDER RUMBLE STRIPS	15,600.00	LF		\$	
0150	02697		EDGE LINE RUMBLE STRIPS	26,950.00	LF		\$	
0160	02775		ARROW PANEL	2.00	EACH		\$	
0170	04792		CONDUIT-1 IN	110.00	LF		\$	
0180	04811		ELECTRICAL JUNCTION BOX TYPE B	11.00	EACH		\$	
0190	04820		TRENCHING AND BACKFILLING	1,330.00	LF		\$	
0200	04830		LOOP WIRE	3,450.00	LF		\$	
0210	04850		CABLE-NO. 14/1 PAIR	6,775.00	LF		\$	
0220	04895		LOOP SAW SLOT AND FILL	1,428.00	LF		\$	
0230	06510		PAVE STRIPING-TEMP PAINT-4 IN	30,500.00	LF		\$	
0240	06515		PAVE STRIPING-PERM PAINT-6 IN	10,000.00	LF		\$	
0250	06542		PAVE STRIPING-THERMO-6 IN W	51,600.00	LF		\$	
0260	06543		PAVE STRIPING-THERMO-6 IN Y	55,250.00	LF		\$	
0270	06568		PAVE MARKING-THERMO STOP BAR-24IN	546.00	LF		\$	
0280	06569		PAVE MARKING-THERMO CROSS-HATCH	1,726.00	SQFT		\$	
0290	06574		PAVE MARKING-THERMO CURV ARROW	53.00	EACH		\$	
0300	06575		PAVE MARKING-THERMO COMB ARROW	2.00	EACH		\$	
0310	06576		PAVE MARKING-THERMO ONLY	2.00	EACH		\$	
0320	06578		PAVE MARKING-THERMO MERGE ARROW	3.00	EACH		\$	
0330	06600		REMOVE PAVEMENT MARKER TYPE V	529.00	EACH		\$	
0340	10020NS		FUEL ADJUSTMENT	13,368.00	DOLL	\$1.00	\$	\$13,368.00
0350	10030NS		ASPHALT ADJUSTMENT	33,576.00	DOLL	\$1.00	\$	\$33,576.00
0360	24679ED		PAVE MARK THERMO CHEVRON	625.00	SQFT		\$	
0370	24900EC		PVC CONDUIT-1 1/4 IN-SCHEDULE 80	820.00	LF		\$	
0380	24901EC		PVC CONDUIT-2 IN-SCHEDULE 80	210.00	LF		\$	
0390	24955ED		REMOVE SIGNAL EQUIPMENT	2.00	EACH		\$	
0400	24963ED		LOOP TEST	17.00	EACH		\$	

**Section: 0002 - DEMOBILIZATION**

222287

### PROPOSAL BID ITEMS

Page 2 of 2

Report Date 4/21/22

LINE	BID CODE	ALT	DESCRIPTION	QUANTITY	UNIT	UNIT PRIC	FP	AMOUNT
0410	02569		DEMOBILIZATION	1.00	LS		\$	