



CALL NO. 200

CONTRACT ID. 211049

FAYETTE COUNTY

FED/STATE PROJECT NUMBER 034GR21D049-NHPP

DESCRIPTION I-75/ I-64 Split

WORK TYPE ASPHALT REHAB INTERSTATE/PARKWAY

PRIMARY COMPLETION DATE 8/15/2022

LETTING DATE: November 19,2021

Sealed Bids will be received electronically through the Bid Express bidding service until 10:00 am EASTERN STANDARD TIME November 19,2021. Bids will be publicly announced at 10:00 am EASTERN STANDARD TIME.

NO PLANS ASSOCIATED WITH THIS PROJECT.

DBE CERTIFICATION REQUIRED - 14%

REQUIRED BID PROPOSAL GUARANTY: Not less than 5% of the total bid.

TABLE OF CONTENTS

PART I	SCOPE OF WORK
	<ul style="list-style-type: none">• PROJECT(S), COMPLETION DATE(S), & LIQUIDATED DAMAGES• CONTRACT NOTES• FEDERAL CONTRACT NOTES• ASPHALT MIXTURE• DGA BASE• DGA BASE FOR SHOULDERS• INCIDENTAL SURFACING• JPC RIDE QUALITY• FUEL AND ASPHALT PAY ADJUSTMENT• ASPHALT PAVEMENT RIDE QUALITY CAT A• COMPACTION OPTION A• SPECIAL NOTE(S) APPLICABLE TO PROJECT• RIGHT OF WAY CERTIFICATION• UTILITY IMPACT & RAIL CERTIFICATION NOTES• MATERIAL SUMMARY• GUARDRAIL DELIVERY VERIFICATION SHEET
PART II	SPECIFICATIONS AND STANDARD DRAWINGS
	<ul style="list-style-type: none">• SPECIFICATIONS REFERENCE• SUPPLEMENTAL SPECIFICATION• [SN-1I] PORTABLE CHANGEABLE SIGNS• [SN-11N] LONGITUDINAL PAVEMENT JOINT ADHESIVE
PART III	EMPLOYMENT, WAGE AND RECORD REQUIREMENTS
	<ul style="list-style-type: none">• FEDERAL-AID CONSTRUCTION CONTRACTS - FHWA 1273• NONDISCRIMINATION OF EMPLOYEES• EXECUTIVE BRANCH CODE OF ETHICS• PROJECT WAGE RATES LOCALITY 3 / FEDERAL• NOTICE OF REQUIREMENT FOR AFFIRMATIVE ACTION TO ENSURE EEO FAYETTE
PART IV	INSURANCE
PART V	BID ITEMS

PART I
SCOPE OF WORK

ADMINISTRATIVE DISTRICT - 07

CONTRACT ID - 211049

034GR21D049-NHPP

COUNTY - FAYETTE

PCN - DE03400642149

NHPP 0645 (081)

I-64 (MP 81.037) ADDRESS PAVEMENT CONDITION ON I-64 IN BOTH DIRECTIONS FROM MP 81.037 TO MP 82.19 IN FAYETTE COUNTY (MP 82.19), A DISTANCE OF 01.15 MILES.JPC PAVEMENT REPAIRS - DIAMOND GRINDING SYP NO. 07-20010.00.

GEOGRAPHIC COORDINATES LATITUDE 38:03:19.00 LONGITUDE 84:25:46.00

PCN - DE03400752149

NHPP 0645 (081)

I-75 (MP 107.453) ADDRESS PAVEMENT CONDITION ON I-75 IN BOTH DIRECTIONS FROM MP 107.453 TO MP 111.95 IN FAYETTE COUNTY (MP 111.95), A DISTANCE OF 04.50 MILES.ASPHALT REHAB INTERSTATE/ PARKWAY SYP NO. 07-20013.00.

GEOGRAPHIC COORDINATES LATITUDE 38:03:19.00 LONGITUDE 84:25:46.00

COMPLETION DATE(S):

COMPLETED BY 10/31/2022

APPLIES TO ALL PROPOSED
ASPHALT WORK ON I-64 AND I-75

COMPLETED BY 08/15/2022

APPLIES TO ALL PROPOSED
CONCRETE WORK ON I-64

CONTRACT NOTES

PROPOSAL ADDENDA

All addenda to this proposal must be applied when calculating bid and certified in the bid packet submitted to the Kentucky Department of Highways. Failure to use the correct and most recent addenda may result in the bid being rejected.

BID SUBMITTAL

Bidder must use the Department's electronic bidding software. The Bidder must download the bid file located on the Bid Express website (www.bidx.com) to prepare a bid packet for submission to the Department. The bidder must submit electronically using Bid Express.

JOINT VENTURE BIDDING

Joint venture bidding is permissible. All companies in the joint venture must be prequalified in one of the work types in the Qualifications for Bidders for the project. The bidders must get a vendor ID for the joint venture from the Division of Construction Procurement and register the joint venture as a bidder on the project. Also, the joint venture must obtain a digital ID from Bid Express to submit a bid. A joint bid bond of 5% may be submitted for both companies or each company may submit a separate bond of 5%.

UNDERGROUND FACILITY DAMAGE PROTECTION

The contractor shall make every effort to protect underground facilities from damage as prescribed in the Underground Facility Damage Protection Act of 1994, Kentucky Revised Statute KRS 367.4901 to 367.4917. It is the contractor's responsibility to determine and take steps necessary to be in compliance with federal and state damage prevention directives. When prescribed in said directives, the contractor shall submit Excavation Locate Requests to the Kentucky Contact Center (KY811) via web ticket entry. The submission of this request does not relieve the contractor from the responsibility of contacting non-member facility owners, whom shall be contacted through their individual Protection Notification Center. Non-compliance with these directives can result in the enforcement of penalties.

REGISTRATION WITH THE SECRETARY OF STATE BY A FOREIGN ENTITY

Pursuant to KRS 176.085(1)(b), an agency, department, office, or political subdivision of the Commonwealth of Kentucky shall not award a state contract to a person that is a foreign entity required by [KRS 14A.9-010](#) to obtain a certificate of authority to transact business in the Commonwealth ("certificate") from the Secretary of State under [KRS 14A.9-030](#) unless the person produces the certificate within fourteen (14) days of the bid or proposal opening. If the foreign entity is not required to obtain a certificate as provided in [KRS 14A.9-010](#), the foreign entity should identify the applicable exception. Foreign entity is defined within [KRS 14A.1-070](#).

For all foreign entities required to obtain a certificate of authority to transact business in the Commonwealth, if a copy of the certificate is not received by the contracting agency within the time frame identified above, the foreign entity's solicitation response shall be deemed non-responsive or the awarded contract shall be cancelled.

Businesses can register with the Secretary of State at <https://secure.kentucky.gov/sos/ftbr/welcome.aspx>.

SPECIAL NOTE FOR PROJECT QUESTIONS DURING ADVERTISEMENT

Questions about projects during the advertisement should be submitted in writing to the Division of Construction Procurement. This may be done by fax (502) 564-7299 or email to kytc.projectquestions@ky.gov. The Department will attempt to answer all submitted questions. The Department reserves the right not to answer if the question is not pertinent or does not aid in clarifying the project intent.

The deadline for posting answers will be 3:00 pm Eastern Daylight Time, the day preceding the Letting. Questions may be submitted until this deadline with the understanding that the later a question is submitted, the less likely an answer will be able to be provided.

The questions and answers will be posted for each Letting under the heading "Questions & Answers" on the Construction Procurement website (www.transportation.ky.gov/contract). The answers provided shall be considered part of this Special Note and, in case of a discrepancy, will govern over all other bidding documents.

HARDWOOD REMOVAL RESTRICTIONS

The US Department of Agriculture has imposed a quarantine in Kentucky and several surrounding states, to prevent the spread of an invasive insect, the emerald ash borer. Hardwood cut in conjunction with the project may not be removed from the state. Chipping or burning on site is the preferred method of disposal.

INSTRUCTIONS FOR EXCESS MATERIAL SITES AND BORROW SITES

Identification of excess material sites and borrow sites shall be the responsibility of the Contractor. The Contractor shall be responsible for compliance with all applicable state and federal laws and may wish to consult with the US Fish and Wildlife Service to seek protection under Section 10 of the Endangered Species Act for these activities.

ACCESS TO RECORDS

The contractor, as defined in KRS 45A.030 (9) agrees that the contracting agency, the Finance and Administration Cabinet, the Auditor of Public Accounts, and the Legislative Research Commission, or their duly authorized representatives, shall have access to any books, documents, papers, records, or other evidence, which are directly pertinent to this contract for the purpose of financial audit or program review. Records and other prequalification information confidentially

disclosed as part of the bid process shall not be deemed as directly pertinent to the contract and shall be exempt from disclosure as provided in KRS 61.878(1)(c). The contractor also recognizes that any books, documents, papers, records, or other evidence, received during a financial audit or program review shall be subject to the Kentucky Open Records Act, KRS 61.870 to 61.884.

In the event of a dispute between the contractor and the contracting agency, Attorney General, or the Auditor of Public Accounts over documents that are eligible for production and review, the Finance and Administration Cabinet shall review the dispute and issue a determination, in accordance with Secretary's Order 11-004.

April 30, 2018

FEDERAL CONTRACT NOTES

The Kentucky Department of Highways, in accordance with the Regulations of the United States Department of Transportation 23 CFR 635.112 (h), hereby notifies all bidders that failure by a bidder to comply with all applicable sections of the current Kentucky Standard Specifications, including, but not limited to the following, may result in a bid not being considered responsive and thus not eligible to be considered for award:

- | | |
|--------------------------------|--|
| 102.02 Current Rating | 102.08 Preparation and Delivery of Proposals |
| 102.13 Irregular Bid Proposals | 102.14 Disqualification of Bidders |
| 102.09 Proposal Guaranty | |

CIVIL RIGHTS ACT OF 1964

The Kentucky Department of Highways, in accordance with the provisions of Title VI of the Civil Rights Act of 1964 (78 Stat. 252) and the Regulations of the Federal Department of Transportation (49 C.F.R., Part 21), issued pursuant to such Act, hereby notifies all bidders that it will affirmatively insure that the contract entered into pursuant to this advertisement will be awarded to the lowest responsible bidder without discrimination on the ground of race, color, or national origin.

NOTICE TO ALL BIDDERS

To report bid rigging activities call: 1-800-424-9071.

The U.S. Department of Transportation (DOT) operates the above toll-free “hotline” Monday through Friday, 8:00 a.m. to 5:00 p.m. eastern time. Anyone with knowledge of possible bid rigging, bidder collusion, or other fraudulent activities should use the “hotline” to report such activities.

The “hotline” is part of the DOT’s continuing effort to identify and investigate highway construction contract fraud and abuse and is operated under the direction of the DOT Inspector General. All information will be treated confidentially and caller anonymity will be respected.

SECOND TIER SUBCONTRACTS

Second tier subcontracts are acceptable per Section 108.01 of the Standard Specifications for Road and Bridge Construction. There are special rules to DBE subcontractors satisfying DBE goals on federal-aid projects. 1st-Tier DBE Subcontractors may only enter into a 2nd-Tier subcontract with another DBE contractor.

DISADVANTAGED BUSINESS ENTERPRISE PROGRAM

It is the policy of the Kentucky Transportation Cabinet (“the Cabinet”) that Disadvantaged Business Enterprises (“DBE”) shall have the opportunity to participate in the performance of highway construction projects financed in whole or in part by Federal Funds in order to create a level playing field for all businesses who wish to contract with the Cabinet. To that end, the Cabinet will comply with the regulations found in 49 CFR Part 26, and the definitions and requirements contained therein shall be adopted as if set out verbatim herein.

The Cabinet, contractors, subcontractors, and sub-recipients shall not discriminate on the basis of race, color, national origin, or sex in the performance of work performed pursuant to Cabinet contracts. The contractor shall carry out applicable requirements of 49 CFR 26 in the award and administration of federally assisted highway construction projects. The contractor will include this provision in all its subcontracts and supply agreements pertaining to contracts with the Cabinet.

Failure by the contractor to carry out these requirements is a material breach of its contract with the Cabinet, which may result in the termination of the contract or such other remedy as the Cabinet deems necessary.

DBE GOAL

The Disadvantaged Business Enterprise (DBE) goal established for this contract, as listed on the front page of the proposal, is the percentage of the total value of the contract.

The contractor shall exercise all necessary and reasonable steps to ensure that Disadvantaged Business Enterprises participate in a least the percent of the contract as set forth above as goals for this contract.

OBLIGATION OF CONTRACTORS

Each contractor prequalified to perform work on Cabinet projects shall designate and make known to the Cabinet a liaison officer who is assigned the responsibility of effectively administering and promoting an active program for utilization of DBEs.

If a formal goal has not been designated for the contract, all contractors are encouraged to consider DBEs for subcontract work as well as for the supply of material and services needed to perform this work.

Contractors are encouraged to use the services of banks owned and controlled by minorities and women.

CERTIFICATION OF CONTRACT GOAL

Contractors shall include the following certification in bids for projects for which a DBE goal has been established. BIDS SUBMITTED WHICH DO NOT INCLUDE CERTIFICATION OF DBE PARTICIPATION WILL NOT BE ACCEPTED. These bids will not be considered for award by the Cabinet and they will be returned to the bidder.

“The bidder certifies that it has secured participation by Disadvantaged Business Enterprises (“DBE”) in the amount of _____ percent of the total value of this contract and that the DBE participation is in compliance with the requirements of 49 CFR 26 and the policies of the Kentucky Transportation Cabinet pertaining to the DBE Program.”

The certification statement is located in the electronic bid file. All contractors must certify their DBE participation on that page. DBEs utilized in achieving the DBE goal must be certified and prequalified for the work items at the time the bid is submitted.

DBE PARTICIPATION PLAN

Lowest responsive bidders must submit the *DBE Plan/ Subcontractor Request*, form TC 14-35 DBE, within **5** days of the letting. This is necessary before the Awards Committee will review and make a recommendation. **The project will not be considered for award prior to submission and approval of the apparent low bidder’s DBE Plan/Subcontractor Request.**

The DBE Participation Plan shall include the following:

1. Name and address of DBE Subcontractor(s) and/or supplier(s) intended to be used in the proposed project;
2. Description of the work each is to perform including the work item, unit, quantity, unit price and total amount of the work to be performed by the individual DBE. The Proposal Line Number, Category Number, and the Project Line Number can be found in the “material listing” on the Construction Procurement website under the specific letting;
3. The dollar value of each proposed DBE subcontract and the percentage of total project contract value this represents. DBE participation may be counted as follows:
 - a. If DBE suppliers and manufactures assume actual and contractual responsibility, the dollar value of materials to be furnished will be counted toward the goal as follows:
 - The entire expenditure paid to a DBE manufacturer;
 - 60 percent of expenditures to DBE suppliers that are not manufacturers provided the supplier is a regular dealer in the product involved. A regular dealer must be engaged in, as its principal business and in its own name, the sale of products to the public, maintain an inventory and own and operate distribution equipment; and
 - The amount of fees or commissions charged by the DBE firms for a bona fide service, such as professional, technical, consultant, or managerial services and assistance in the procurement of essential personnel, facilities, equipment, materials, supplies, delivery of materials and supplies or for furnishing bonds, or insurance, providing such fees or commissions are determined to be reasonable and customary.

- b) The dollar value of services provided by DBEs such as quality control testing, equipment repair and maintenance, engineering, staking, etc.;
 - c) The dollar value of joint ventures. DBE credit for joint ventures will be limited to the dollar amount of the work actually performed by the DBE in the joint venture;
4. Written and signed documentation of the bidder's commitment to use a DBE contractor whose participation is being utilized to meet the DBE goal; and
 5. Written and signed confirmation from the DBE that it is participating in the contract as provided in the prime contractor's commitment.

UPON AWARD AND BEFORE A WORK ORDER WILL BE ISSUED

Contractors must submit the signed subcontract between the contractor and the DBE contractor, along with the DBE's certificate of insurance. If the DBE is a supplier of materials for the project, a signed purchase order must be submitted to the Division of Construction Procurement.

Changes to DBE Participation Plans must be approved by the Cabinet. The Cabinet may consider extenuating circumstances including, but not limited to, changes in the nature or scope of the project, the inability or unwillingness of a DBE to perform the work in accordance with the bid, and/or other circumstances beyond the control of the prime contractor.

CONSIDERATION OF GOOD FAITH EFFORTS REQUESTS

If the DBE participation submitted in the bid by the apparent lowest responsive bidder does not meet or exceed the DBE contract goal, the apparent lowest responsive bidder must submit a Good Faith Effort Package to satisfy the Cabinet that sufficient good faith efforts were made to meet the contract goals prior to submission of the bid. Efforts to increase the goal after bid submission will not be considered in justifying the good faith effort, unless the contractor can show that the proposed DBE was solicited prior to the letting date. DBEs utilized in achieving the DBE goal must be certified and prequalified for the work items at the time the bid is submitted. One complete set (hard copy along with an electronic copy) of this information must be received in the Division of Contract Procurement no later than 12:00 noon of the tenth calendar day after receipt of notification that they are the apparent low bidder.

Where the information submitted includes repetitious solicitation letters it will be acceptable to submit a sample representative letter along with a distribution list of the firms solicited. Documentation of DBE quotations shall be a part of the good faith effort submittal as necessary to demonstrate compliance with the factors listed below which the Cabinet considers in judging good faith efforts. This documentation may include written subcontractors' quotations, telephone log notations of verbal quotations, or other types of quotation documentation.

The Good Faith Effort Package shall include, but may not be limited to information showing evidence of the following:

1. Whether the bidder attended any pre-bid meetings that were scheduled by the Cabinet to inform DBEs of subcontracting opportunities;
2. Whether the bidder provided solicitations through all reasonable and available means;
3. Whether the bidder provided written notice to all DBEs listed in the DBE directory at the time of the letting who are prequalified in the areas of work that the bidder will be subcontracting;
4. Whether the bidder followed up initial solicitations of interest by contacting DBEs to determine with certainty whether they were interested. If a reasonable amount of DBEs within the targeted districts do not provide an intent to quote or no DBEs are prequalified in the subcontracted areas, the bidder must notify the Disadvantaged Enterprise Business Liaison Officer (DEBLO) in the Office of Civil Rights and Small Business Development to give notification of the bidder's inability to get DBE quotes;
5. Whether the bidder selected portions of the work to be performed by DBEs in order to increase the likelihood of meeting the contract goals. This includes, where appropriate, breaking out contract work items into economically feasible units to facilitate DBE participation, even when the prime contractor might otherwise perform these work items with its own forces;
6. Whether the bidder provided interested DBEs with adequate and timely information about the plans, specifications, and requirements of the contract;
7. Whether the bidder negotiated in good faith with interested DBEs not rejecting them as unqualified without sound reasons based on a thorough investigation of their capabilities. Any rejection should be so noted in writing with a description as to why an agreement could not be reached;
8. Whether quotations were received from interested DBE firms but were rejected as unacceptable without sound reasons why the quotations were considered unacceptable. The fact that the DBE firm's quotation for the work is not the lowest quotation received will not in itself be considered as a sound reason for rejecting the quotation as unacceptable. The fact that the bidder has the ability and/or desire to perform the contract work with its own forces will not be considered a sound reason for rejecting a DBE quote. Nothing in this provision shall be construed to require the bidder to accept unreasonable quotes in order to satisfy DBE goals;
9. Whether the bidder specifically negotiated with subcontractors to assume part of the responsibility to meet the contract DBE goal when the work to be subcontracted includes potential DBE participation;
10. Whether the bidder made any efforts and/or offered assistance to interested DBEs in obtaining the necessary equipment, supplies, materials, insurance and/or bonding to satisfy the work requirements of the bid proposal; and
11. Any other evidence that the bidder submits which may show that the bidder has made reasonable good faith efforts to include DBE participation.

FAILURE TO MEET GOOD FAITH REQUIREMENT

Where the apparent lowest responsive bidder fails to submit sufficient participation by DBE firms to meet the contract goal and upon a determination by the Good Faith Committee based upon the information submitted that the apparent lowest responsive bidder failed to make sufficient reasonable efforts to meet the contract goal, the bidder will be offered the opportunity to meet in person for administrative reconsideration. The bidder will be notified of the Committee's decision within 24 hours of its decision. The bidder will have 24 hours to request reconsideration of the Committee's decision. The reconsideration meeting will be held within two days of the receipt of a request by the bidder for reconsideration.

The request for reconsideration will be heard by the Office of the Secretary. The bidder will have the opportunity to present written documentation or argument concerning the issue of whether it met the goal or made an adequate good faith effort. The bidder will receive a written decision on the reconsideration explaining the basis for the finding that the bidder did or did not meet the goal or made adequate Good Faith efforts to do so.

The result of the reconsideration process is not administratively appealable to the Cabinet or to the United States Department of Transportation.

The Cabinet reserves the right to award the contract to the next lowest responsive bidder or to rebid the contract in the event that the contract is not awarded to the low bidder as the result of a failure to meet the good faith requirement.

SANCTIONS FOR FAILURE TO MEET DBE REQUIREMENTS OF THE PROJECT

Failure by the prime contractor to fulfill the DBE requirements of a project under contract or to demonstrate good faith efforts to meet the goal constitutes a breach of contract. When this occurs, the Cabinet will hold the prime contractor accountable, as would be the case with all other contract provisions. Therefore, the contractor's failure to carry out the DBE contract requirements shall constitute a breach of contract and as such the Cabinet reserves the right to exercise all administrative remedies at its disposal including, but not limited to the following:

- Suspension of Prequalification;
- Disallow credit toward the DBE goal;
- Withholding progress payments;
- Withholding payment to the prime in an amount equal to the unmet portion of the contract goal; and/or
- Termination of the contract.

PROMPT PAYMENT

The prime contractor will be required to pay the DBE and Non-DBE Subcontractors within seven (7) working days after he or she has received payment from the Kentucky Transportation Cabinet for work performed or materials furnished.

CONTRACTOR REPORTING

All contractors must keep detailed records and provide reports to the Cabinet on their progress in meeting the DBE requirement on any highway contract. These records may include, but shall not be limited to payroll, lease agreements, cancelled payroll checks, executed subcontracting agreements, etc. Prime contractors will be required to complete and submit a **signed and notarized** Affidavit of Subcontractor Payment (TC 18-7) and copies of checks for any monies paid to each DBE subcontractor or supplier utilized to meet a DBE goal. These documents must be completed and signed within 7 days of being paid by the Cabinet.

Payment information that needs to be reported includes date the payment is sent to the DBE, check number, Contract ID, amount of payment and the check date. Before Final Payment is made on this contract, the Prime Contractor will certify that all payments were made to the DBE subcontractor and/or DBE suppliers.

******* IMPORTANT *******

Please mail the original, signed and completed TC (18-7) Affidavit of Subcontractor Payment form and all copies of checks for payments listed above to the following address:

Office of Civil Rights and Small Business Development
6th Floor West 200 Mero Street
Frankfort, KY 40622

The prime contractor should notify the KYTC Office of Civil Rights and Small Business Development seven (7) days prior to DBE contractors commencing work on the project. The contact in this office is Mr. Melvin Bynes. Mr. Bynes' current contact information is email address – melvin.bynes2@ky.gov and the telephone number is (502) 564-3601.

DEFAULT OR DECERTIFICATION OF THE DBE

If the DBE subcontractor or supplier is decertified or defaults in the performance of its work, and the overall goal cannot be credited for the uncompleted work, the prime contractor may utilize a substitute DBE or elect to fulfill the DBE goal with another DBE on a different work item. If after exerting good faith effort in accordance with the Cabinet's Good Faith Effort policies and procedures, the prime contractor is unable to replace the DBE, then the unmet portion of the goal may be waived at the discretion of the Cabinet.

PROHIBITION ON TELECOMMUNICATIONS EQUIPMENT OR SERVICES

In accordance with the FY 2019 National Defense Authorization Act (NDAA), 2 CFR 200.216, and 2 CFR 200.471, Federal agencies are prohibited, after August 13, 2020, from obligating or expending financial assistance to obtain certain telecommunications and video surveillance services and equipment from specific producers. As a result of these regulations, contractors and subcontractors are prohibited, on projects with federal funding participation, from providing telecommunication or video surveillance equipment, services, or systems produced by:

- Huawei Technologies Company or ZTE Corporation (or any subsidiary or affiliate of such entities)
- Hytera Communications Corporation, Hangzhou Hikvision Digital Technology Company, or Dahua Technology Company (or any subsidiary or affiliate of such entities)

LEGAL REQUIREMENTS AND RESPONSIBILITY TO THE PUBLIC – CARGO PREFERENCE ACT (CPA).

(REV 12-17-15) (1-16)

SECTION 7 is expanded by the following new Article:

102.10 **Cargo Preference Act – Use of United States-flag vessels.**

Pursuant to Title 46CFR Part 381, the Contractor agrees

- To utilize privately owned United States-flag commercial vessels to ship at least 50 percent of the gross tonnage (computed separately for dry bulk carriers, dry cargo liners, and tankers) involved, whenever shipping any equipment, material, or commodities pursuant to this contract, to the extent such vessels are available at fair and reasonable rates for United States-flag commercial vessels.

- To furnish within 20 days following the date of loading for shipments originating within the United States or within 30 working days following the date of loading for shipments originating outside the United States, a legible copy of a rated, 'on-board' commercial ocean bill-of-lading in English for each shipment of cargo described in paragraph 1 of this section to both the Contracting Officer (through the prime contractor in the case of subcontractor bills-of-lading) and to the Division of National Cargo, Office of Market Development, Maritime Administration, Washington, DC 20590.

- To insert the substance of the provisions of this clause in all subcontracts issued pursuant to this contract.

ASPHALT MIXTURE

Unless otherwise noted, the Department estimates the rate of application for all asphalt mixtures to be 110 lbs/sy per inch of depth.

DGA BASE

Unless otherwise noted, the Department estimates the rate of application for DGA Base to be 115 lbs/sy per inch of depth.

DGA BASE FOR SHOULDERS

Unless otherwise noted, the Department estimates the rate of application for DGA Base for Shoulders to be 115 lbs/sy per inch of depth. The Department will not measure necessary grading and/or shaping of existing shoulders prior to placing of DGA Base, but shall be incidental to the Contract unit price per ton for DGA Base.

Accept payment at the Contract unit price per ton as full compensation for all labor, materials, equipment, and incidentals for grading and/or shaping of existing shoulders and furnishing, placing, and compacting the DGA Base.

INCIDENTAL SURFACING

The Department has included in the quantities of asphalt mixtures established in the proposal estimated quantities required for resurfacing or surfacing mailbox turnouts, farm field entrances, residential and commercial entrances, curve widening, ramp gores and tapers, and road and street approaches, as applicable. Pave these areas to the limits as shown on Standard Drawing RPM-110-06 or as directed by the Engineer. In the event signal detectors are present in the intersecting streets or roads, pave the crossroads to the right of way limit or back of the signal detector, whichever is the farthest back of the mainline. Surface or resurface these areas as directed by the Engineer. The Department will not measure placing and compacting for separate payment but shall be incidental to the Contract unit price for the asphalt mixtures.

JPC RIDE QUALITY

The Department will apply JPC Ride Quality requirements on this project in accordance with Section 501.03.19(B).

FUEL AND ASPHALT PAY ADJUSTMENT

The Department has included the Contract items Asphalt Adjustment and Fuel Adjustment for possible future payments at an established Contract unit price of \$1.00. The Department will calculate actual adjustment quantities after work is completed. If existing Contract amount is insufficient to pay all items on the contract with the adjustments, the Department will establish additional monies with a change order.

ASPHALT PAVEMENT RIDE QUALITY CATEGORY A

The Department will apply Pavement Rideability Requirements on this project in accordance with Section 410, Category A.

OPTION A

Be advised that the Department will accept compaction of asphalt mixtures furnished for driving lanes and ramps, at 1 inch (25mm) or greater, on this project according to OPTION A in accordance with Section 402 and Section 403 of the current Standard Specifications. The Department will require joint cores as described in Section 402.03.02 for surface mixtures only. The Department will accept compaction of all other asphalt mixtures according to OPTION B.



ITEM NUMBERS: 7-20010 .00 & 7-20013.00

PROJECT NUMBER: FD52 034 0075 107-112 & FD52 034 0064 081-083

CONSTRUCTION NUMBER: NHPP 0645(081)

LETTING DATE: November 19, 2021

RECOMMENDED BY: _____ DATE: _____
Project Manager

PLAN APPROVED BY: _____ DATE: _____
State Highway Engineer

FHWA APPROVED BY: _____ DATE: _____

MATCHLINE
(SEE SHEET 2)

COUNTY OF	ITEM NO.
FAYETTE	7-20010.00 7-20013.00



15" PIPE CULVERT HEADALL
4 LF 15" PIPE
CONNECT TO EXIST.

APPROX. LOCATION
FLUME INLET TY 2

455+00

REMOVE AND RESET GUARDRAIL
CONST. CONC. WEDGE CURB
CONST. FLUME INLETS AT 300'
SPACING OR AS DIRECTED BY
THE ENGINEER.

450+00

445+00

440+00

SB I-75
NB I-75

BEGIN CONSTRUCTION
STA. 444+59.58
MP 107.453

- PAVEMENT REPAIR
- FULL DEPTH CONCRETE REPAIR



SCALE: 1"=200'

COUNTY OF	ITEM NO.
FAYETTE	7-20010.00 7-20013.00

MATCHLINE
(SEE SHEET 3)



MILE
108

REMOVE AND RESET GUARDRAIL
CONST. CONC. WEDGE CURB
CONST. FLUME INLETS AT 300'
SPACING OR AS DIRECTED BY
THE ENGINEER.

REMOVE AND RESET GUARDRAIL
CONST. CONC. WEDGE CURB
CONST. FLUME INLETS AT 300'
SPACING OR AS DIRECTED BY
THE ENGINEER.

15" PIPE CULVERT HEADWALL
4 LF 15" PIPE
CONNECT TO EXIST.

APPROX. LOCATION
LOW WIRES
USE CAUTION

PAYMENT REPAIR
FULL DEPTH CONCRETE REPAIR

0' 200' 400' 800'

SCALE: 1"=200'

I-75 & I-64
STATIONING INFORMATION SHEETS
(2 OF 15)

MATCHLINE
(SEE SHEET 1)

COUNTY OF	ITEM NO.
FAYETTE	7-20010.00 7-20013.00

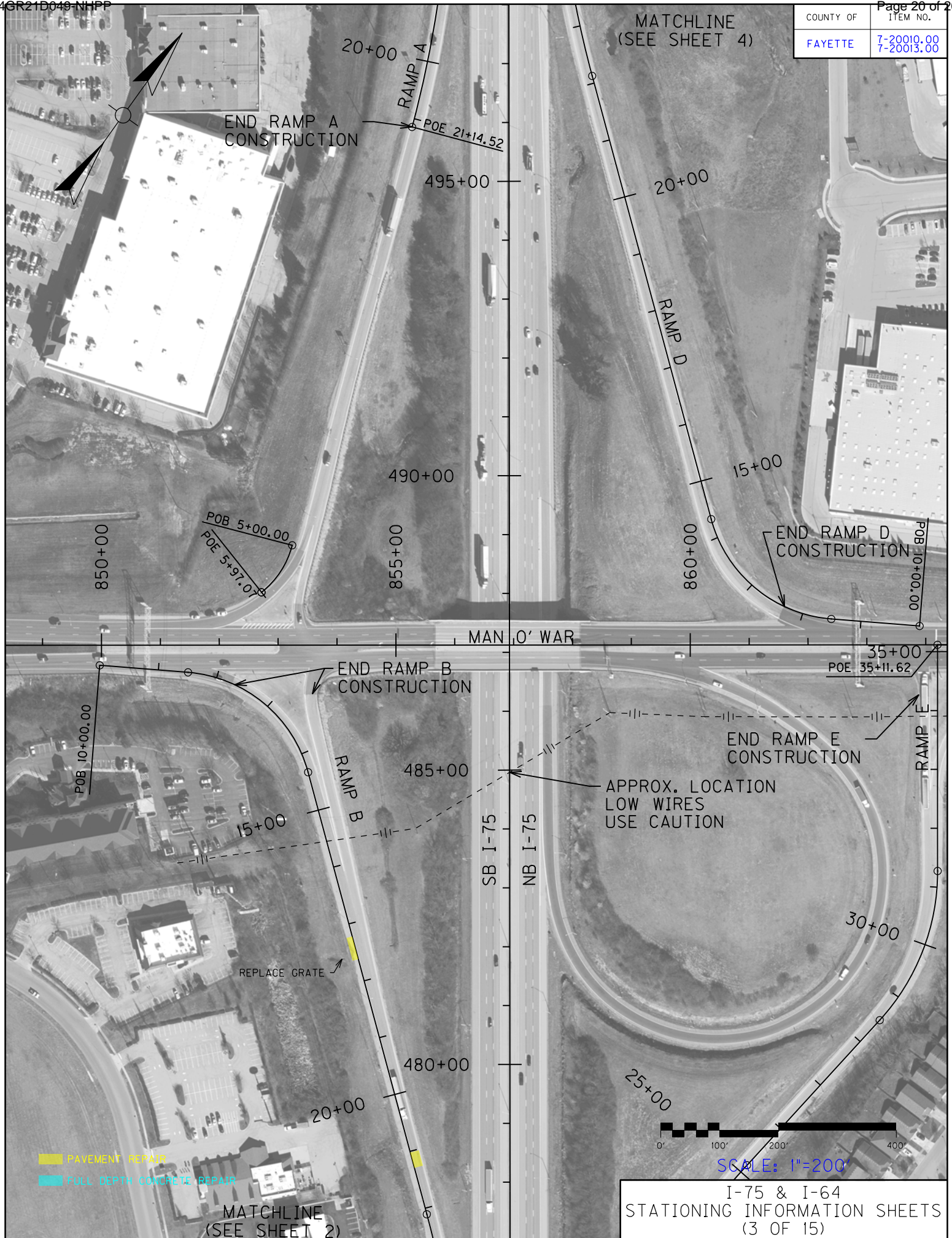

MATCHLINE
(SEE SHEET 4)

END RAMP A
CONSTRUCTION

20+00
RAMP A

495+00

20+00

RAMP D

15+00

END RAMP D
CONSTRUCTION

850+00

POB 5+00.00
POE 5+97.00

490+00

855+00

860+00

POB 10+00.00

MAN O' WAR

END RAMP B
CONSTRUCTION

35+00
POE 35+11.62

POB 10+00.00

RAMP B

485+00

END RAMP E
CONSTRUCTION

APPROX. LOCATION
LOW WIRES
USE CAUTION

15+00

SB I-75
NB I-75

RAMP E

REPLACE GRATE

480+00

30+00

25+00



SCALE: 1"=200'

- PAVEMENT REPAIR
- FULL DEPTH CONCRETE REPAIR

MATCHLINE
(SEE SHEET 2)

I-75 & I-64
STATIONING INFORMATION SHEETS
(3 OF 15)

COUNTY OF	ITEM NO.
FAYETTE	7-20010.00 7-20013.00

MATCHLINE
(SEE SHEET 5)



PAVEMENT REPAIR
 FULL DEPTH CONCRETE REPAIR



SCALE: 1"=200'

MATCHLINE
(SEE SHEET 3)

I-75 & I-64
 STATIONING INFORMATION SHEETS
 (4 OF 15)

COUNTY OF	ITEM NO.
FAYETTE	7-20010.00 7-20013.00



MATCHLINE
(SEE SHEET 6)

535+00

540+00

SB I-75
NB I-75

530+00

525+00

MILE
109

520+00

EONBK 519+34.00
EQNAHD 519+32.00

MATCHLINE
(SEE SHEET 4)

PAVEMENT REPAIR
FULL DEPTH CONCRETE REPAIR



SCALE: 1"=200'

I-75 & I-64
STATIONING INFORMATION SHEETS
(5 OF 15)

COUNTY OF	ITEM NO.
FAYETTE	7-20010.00 7-20013.00

MATCHLINE
(SEE SHEET 7)

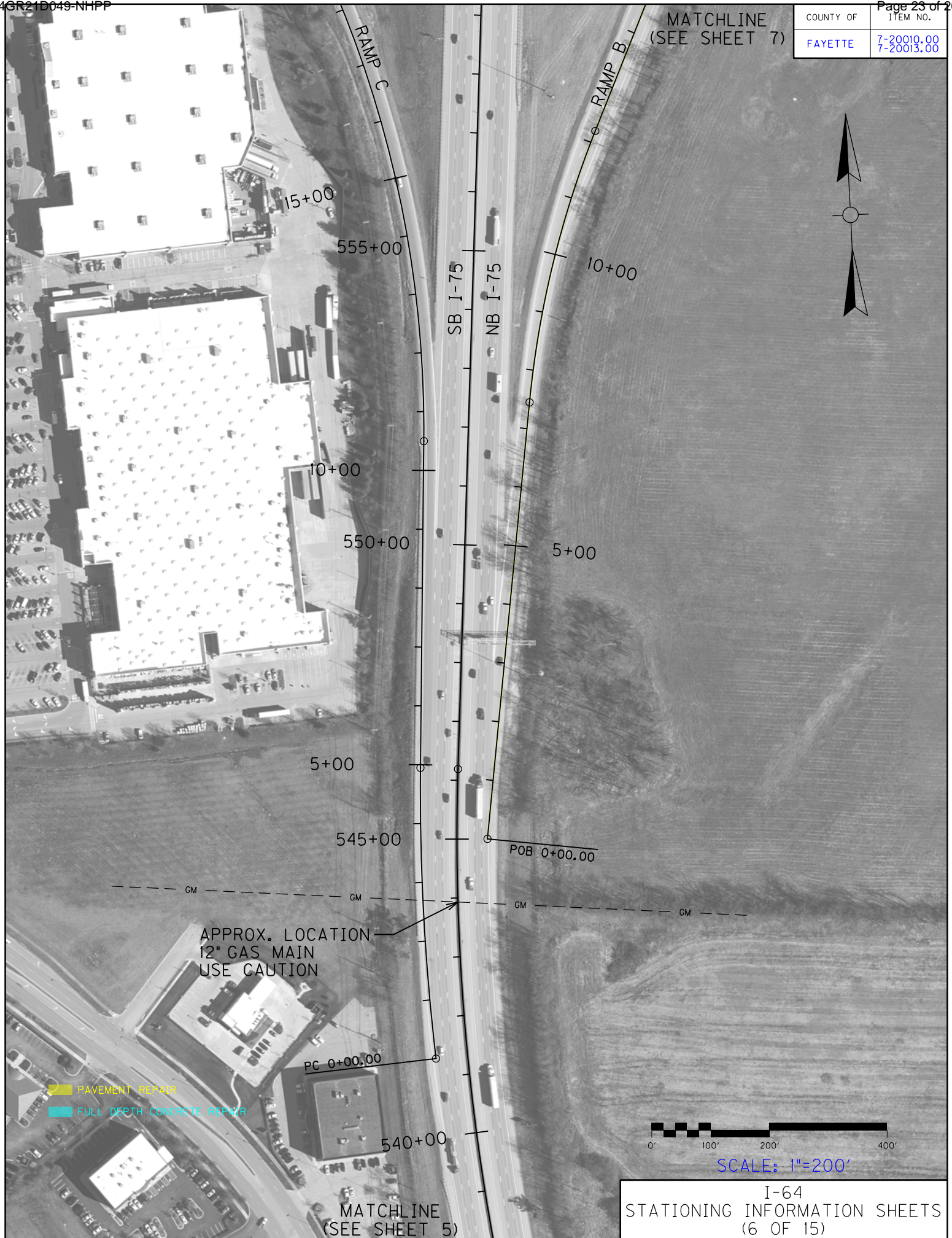

APPROX. LOCATION
12" GAS MAIN
USE CAUTION

- PAVEMENT REPAIR
- FULL DEPTH CONCRETE REPAIR



SCALE: 1"=200'

I-64
STATIONING INFORMATION SHEETS
(6 OF 15)

MATCHLINE
(SEE SHEET 5)

MATCHLINE
(SEE SHEET 8)

COUNTY OF	ITEM NO.
FAYETTE	7-20010.00 7-20013.00

MILE
1
1
0

APPROX. LOCATION
LOW WIRES
USE CAUTION

APPROX. LOCATION
LOW WIRES
USE CAUTION

APPROX. LOCATION
LOW WIRES
USE CAUTION

PAVEMENT REPAIR
FULL DEPTH CONCRETE REPAIR

END RAMP D
CONSTRUCTION

END RAMP A
CONSTRUCTION

END RAMP C
CONSTRUCTION

END RAMP B
CONSTRUCTION

US 60 WINCHESTER ROAD



SCALE: 1"=200'

MATCHLINE
(SEE SHEET 6)

I-75 & I-64
STATIONING INFORMATION SHEETS
(7 OF 15)

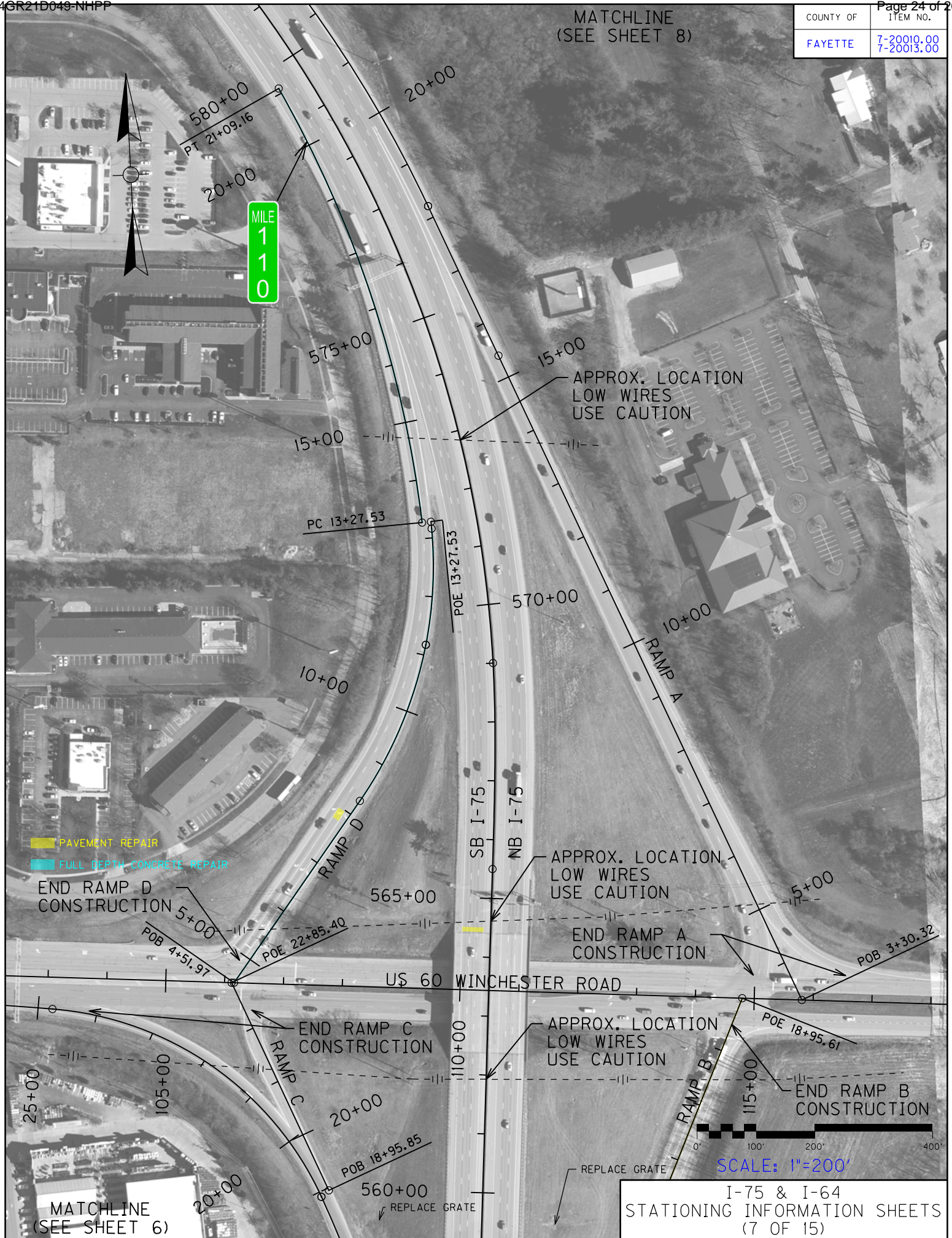

COUNTY OF	ITEM NO.
FAYETTE	7-20010.00 7-20013.00



MATCHLINE
(SEE SHEET 7)

I-75 & I-64
STATIONING INFORMATION SHEETS
(8 OF 15)

COUNTY OF	ITEM NO.
FAYETTE	7-20010.00 7-20013.00

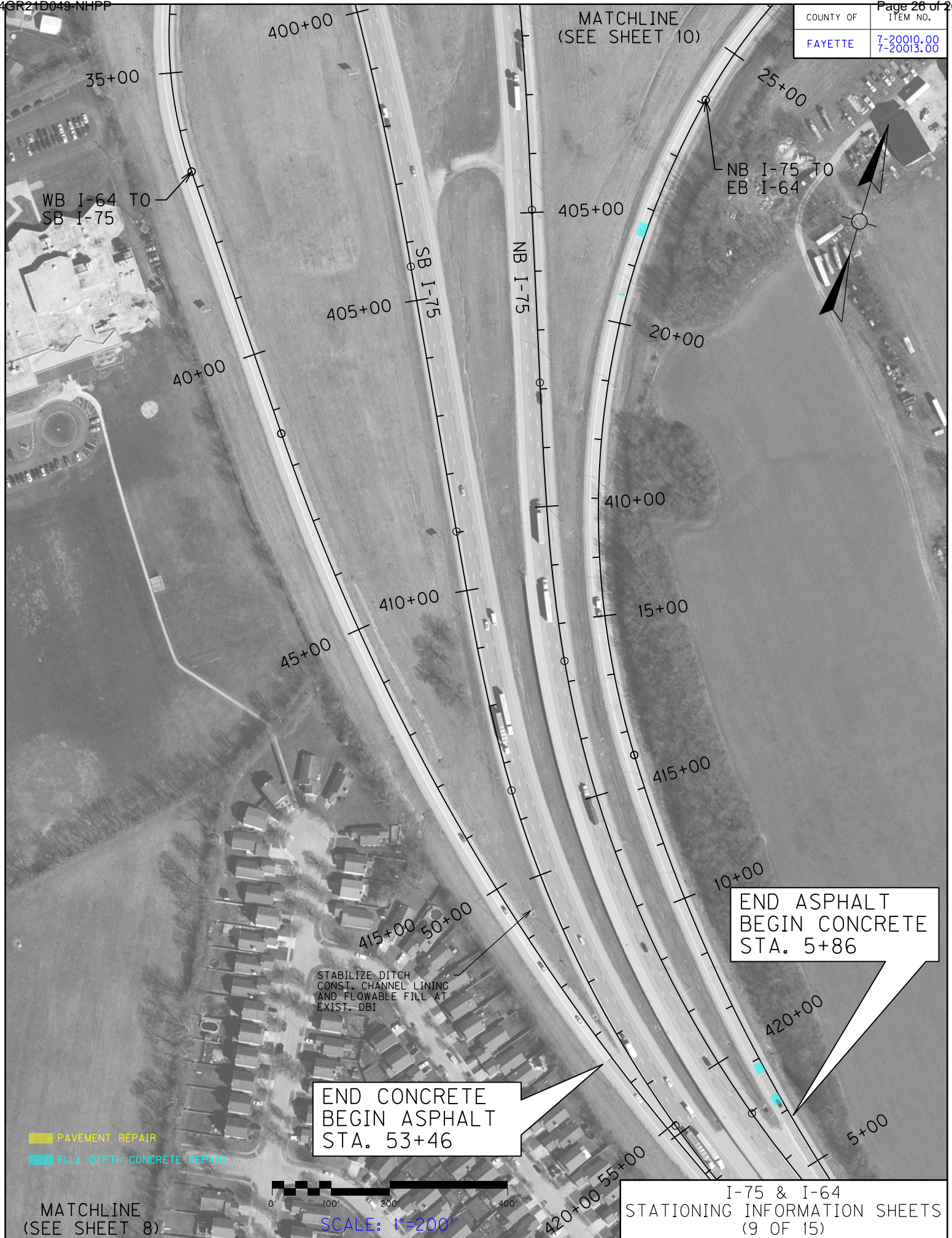

MATCHLINE
(SEE SHEET 10)

WB I-64 TO
SB I-75

NB I-75 TO
EB I-64

END ASPHALT
BEGIN CONCRETE
STA. 5+86

END CONCRETE
BEGIN ASPHALT
STA. 53+46

STABILIZE DITCH
CONST. CHANNEL LINING
AND FLOWABLE FILL AT
EXIST. DBI

- PAVEMENT REPAIR
- FULL DEPTH CONCRETE REPAIR



SCALE: 1"=200'

MATCHLINE
(SEE SHEET 8)

I-75 & I-64
STATIONING INFORMATION SHEETS
(9 OF 15)

MATCHLINE (SEE SHEET 15)

COUNTY OF	ITEM NO.
FAYETTE	7-20010.00 7-20013.00

APPROX. LOCATION
LOW WIRES
USE CAUTION

END ASPHALT
BEGIN CONCRETE
STA. 28+23.23

REPLACE GRATE →

NB I-75 TO
EB I-64

MATCHLINE
(SEE SHEET 9)

SB I-75 TO
EB I-64

WB I-64 TO
SB I-75

WB I-64 TO
NB I-75

END ASPHALT
BEGIN CONCRETE
STA. 44+67.86

CONST. 175 LF GUARDRAIL
STEEL 'W' BEAM-S FACE,
(1) GUARDRAIL END TREATMENT
TYPE 2A, (1) CONN. TO BRIDGE
END TYPE A-1 AND 25 LF
CONC. WEDGE CURB

MILE
1
1
1

REPLACE BROKEN CBI
TYPE B TOP PHASE

MILE
1
1
1

APPROX. LOCATION
LOW WIRES
USE CAUTION

PAVEMENT REPAIR
FULL DEPTH CONCRETE REPAIR



SCALE: 1"=200'

MATCHLINE
(SEE SHEET 11)

I-64 & I-75
STATIONING INFORMATION SHEETS
(10 OF 15)

COUNTY OF	ITEM NO.
FAYETTE	7-20010.00 7-20013.00

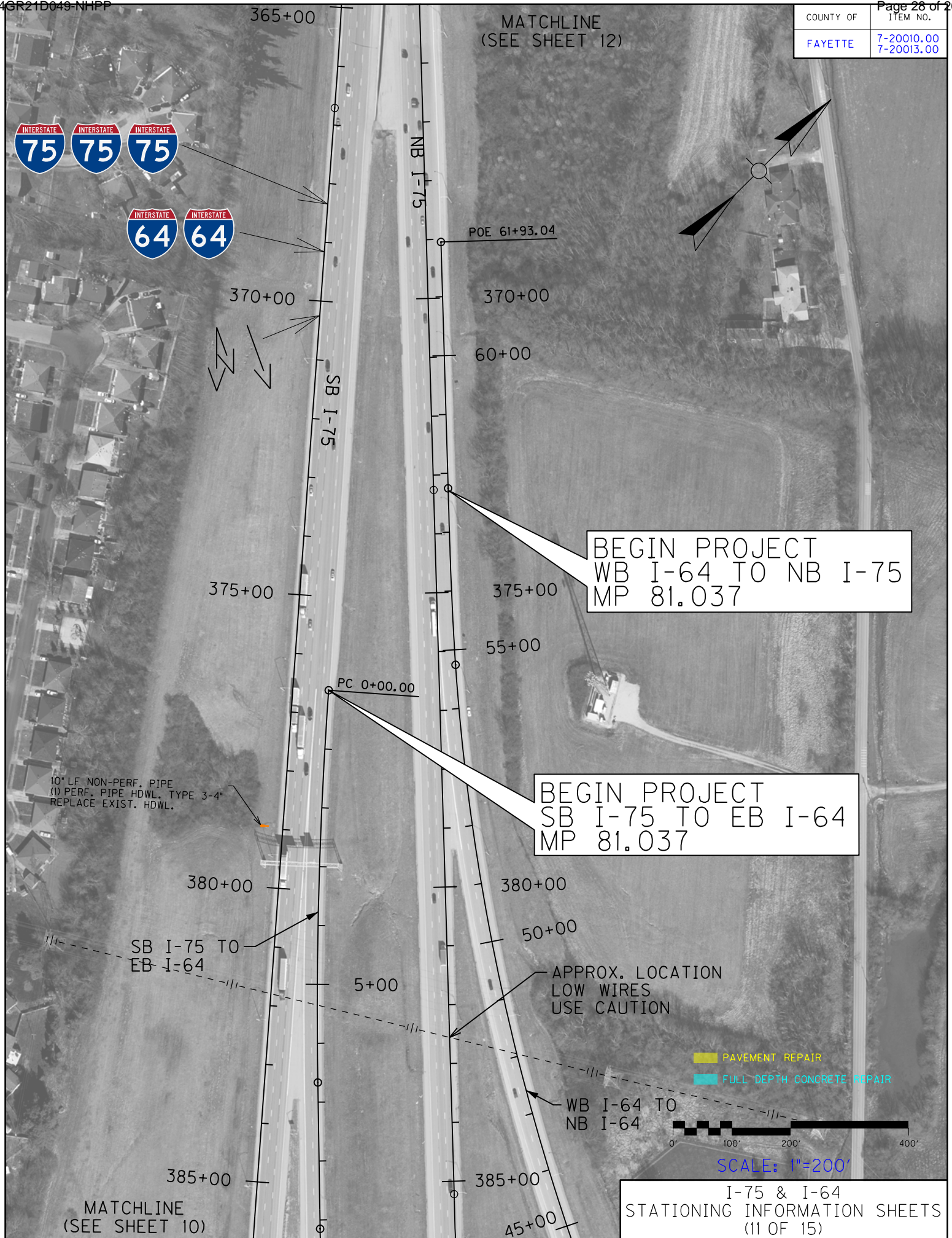

MATCHLINE
(SEE SHEET 12)

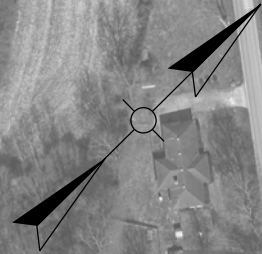

BEGIN PROJECT
WB I-64 TO NB I-75
MP 81.037

BEGIN PROJECT
SB I-75 TO EB I-64
MP 81.037

10" LF NON-PERF. PIPE
(1) PERF. PIPE HDWL. TYPE 3-4"
REPLACE EXIST. HDWL.

APPROX. LOCATION
LOW WIRES
USE CAUTION

PAVEMENT REPAIR
FULL DEPTH CONCRETE REPAIR



SCALE: 1"=200'

I-75 & I-64
STATIONING INFORMATION SHEETS
(11 OF 15)

MATCHLINE
(SEE SHEET 10)

MATCHLINE
(SEE SHEET 13)

COUNTY OF	ITEM NO.
FAYETTE	7-20010.00 7-20013.00



■ PAVEMENT REPAIR
■ FULL DEPTH CONCRETE REPAIR



SCALE: 1"=200'

MATCHLINE
(SEE SHEET 11)

I-75 & I-64
 STATIONING INFORMATION SHEETS
 (12 OF 15)

COUNTY OF	ITEM NO.
FAYETTE	7-20010.00 7-20013.00

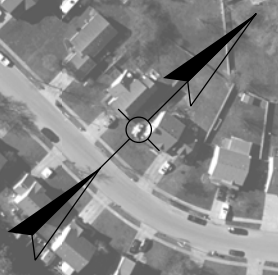

POB 333+00.00

POB 333+00.00

335+00

335+00

APPROX. LOCATION
LOW WIRES
USE CAUTION

MILE
1
1
2

END CONSTRUCTION
STA. 338+89.66
MP 111.95

340+00

340+00

SB I-75

NB I-75

PAVEMENT REPAIR
FULL DEPTH CONCRETE REPAIR



SCALE: 1"=200'

MATCHLINE
(SEE SHEET 12)

I-75 & I-64
STATIONING INFORMATION SHEETS
(13 OF 15)

MATCHLINE
(SEE SHEET 15)

COUNTY OF	ITEM NO.
FAYETTE	7-20010.00 7-20013.00

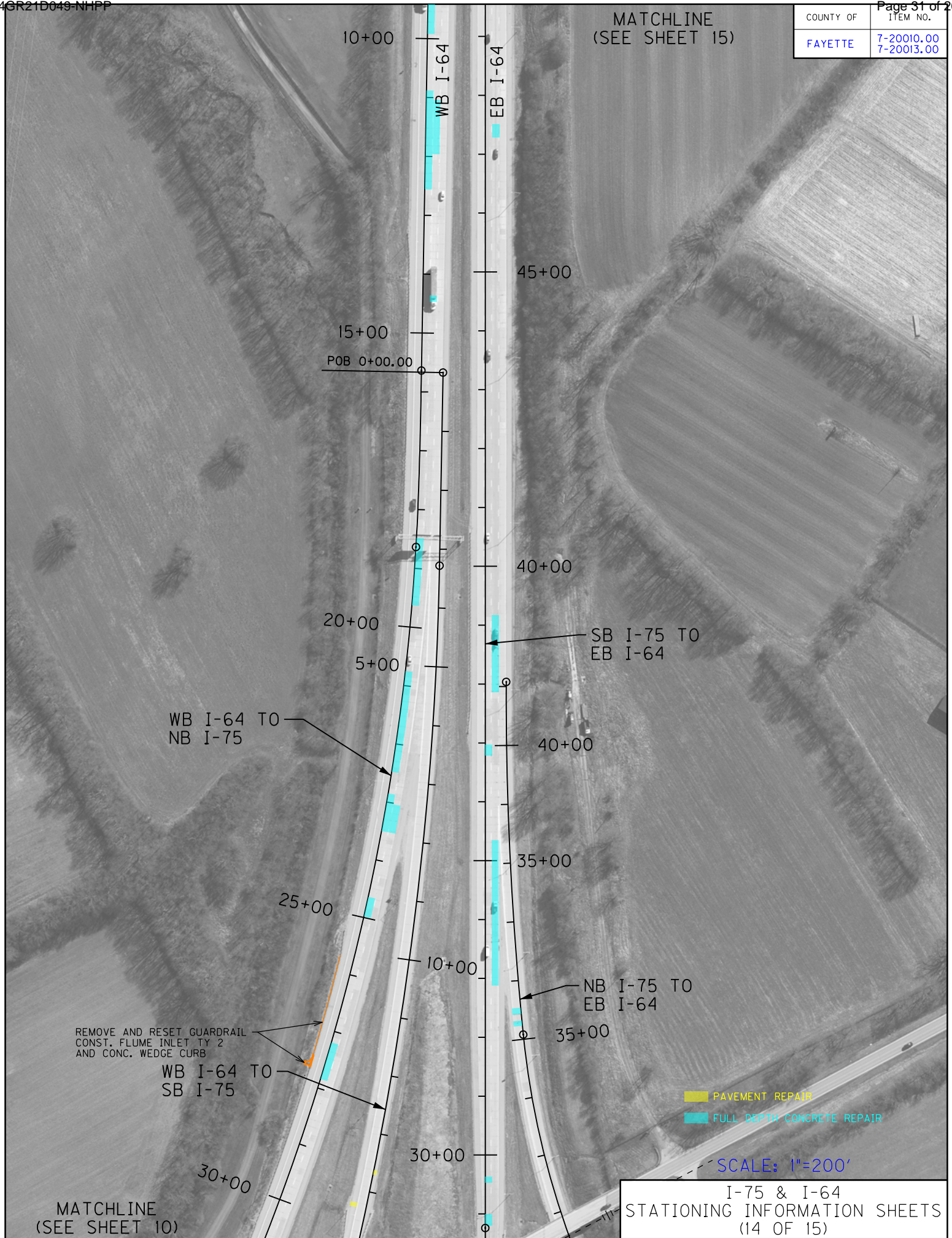

MATCHLINE
(SEE SHEET 10)

SCALE: 1"=200'

I-75 & I-64
STATIONING INFORMATION SHEETS
(14 OF 15)

COUNTY OF	ITEM NO.
FAYETTE	7-20010.00 7-20013.00

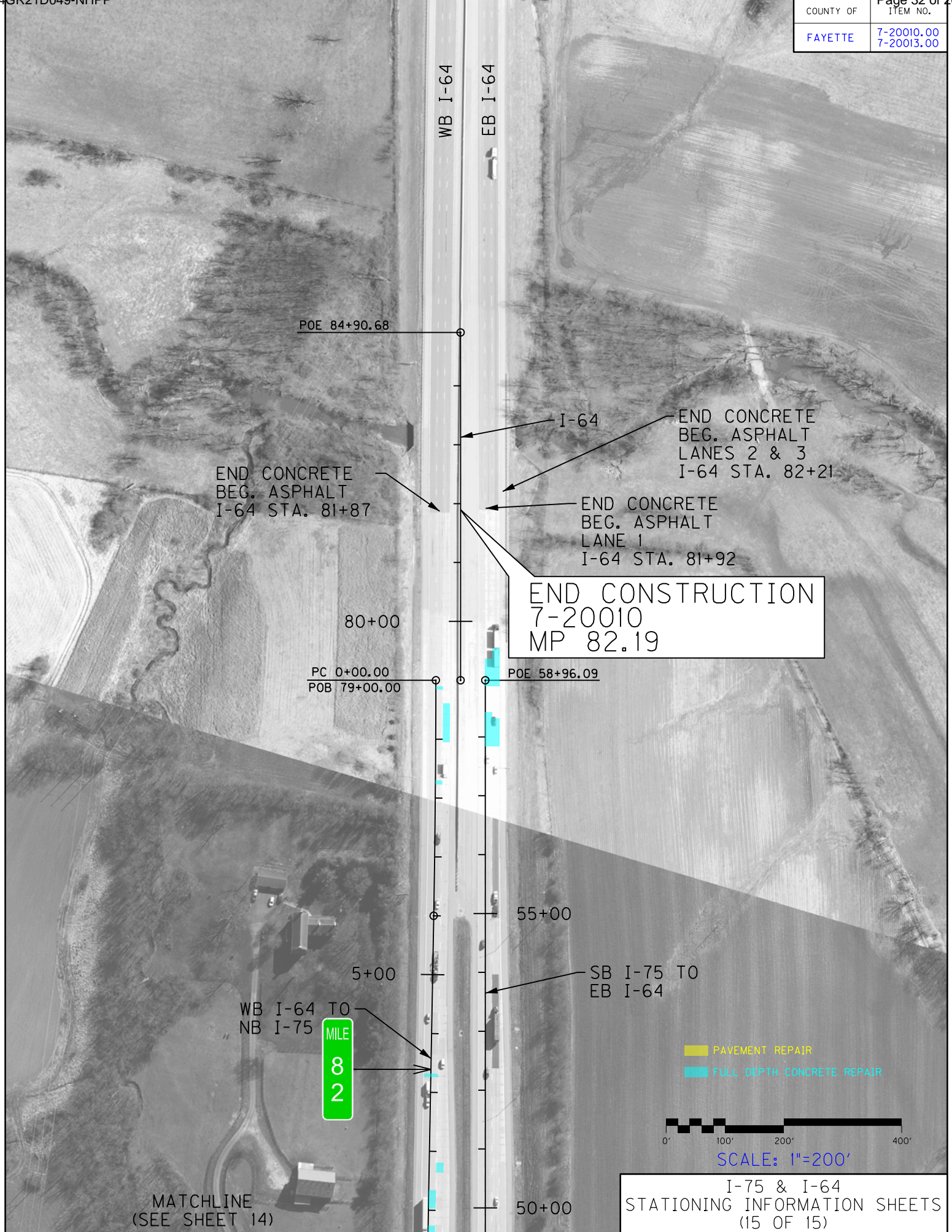

MATCHLINE
(SEE SHEET 14)

I-75 & I-64
STATIONING INFORMATION SHEETS
(15 OF 15)

EXISTING TYPICAL SECTIONS

BARRIER WALL

I-75

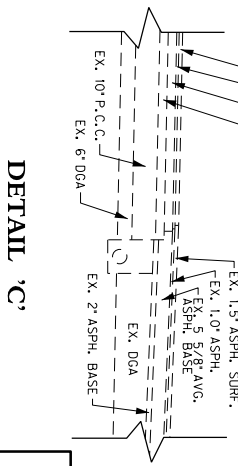
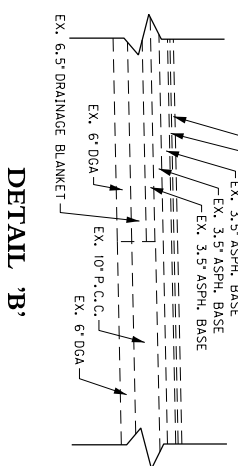
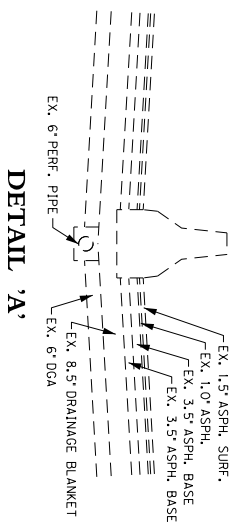
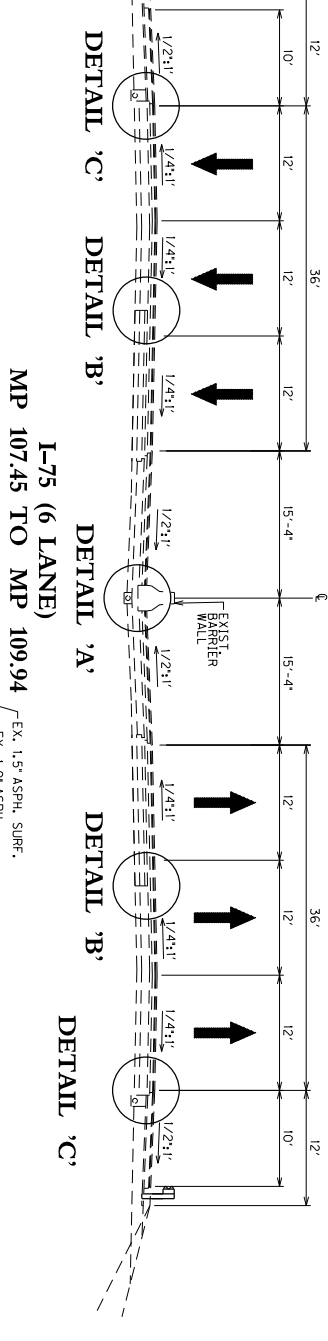
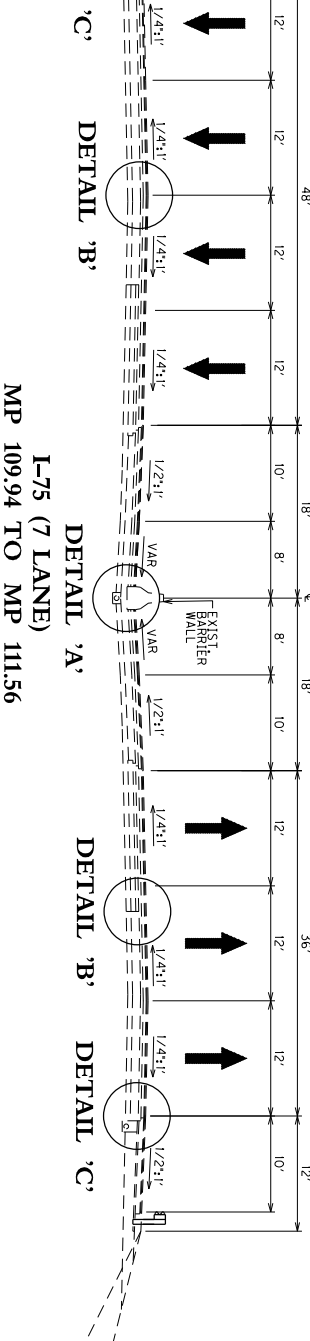
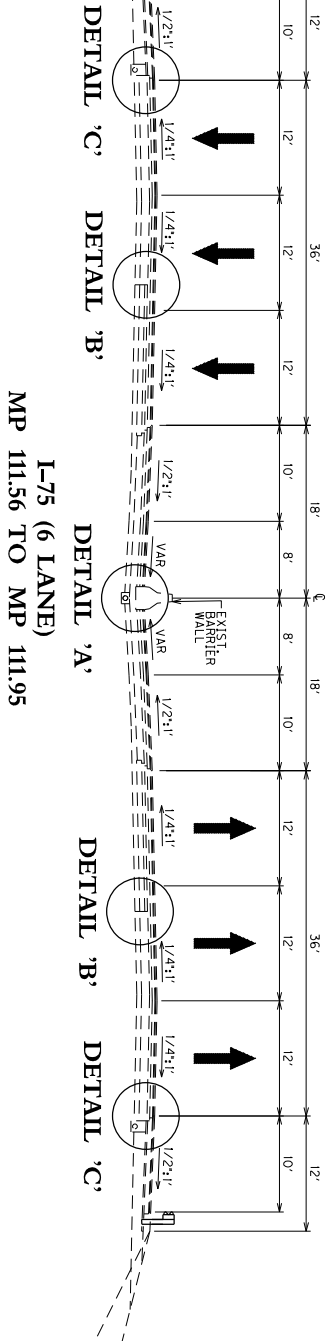

NOT TO SCALE
I-75-I-64
TYPICAL SECTIONS

COUNTY OF	ITEM NO.
FAYETTE	7-20010 & 7-20013

EXISTING TYPICAL SECTIONS EASTBOUND I-64 CONCRETE SECTION

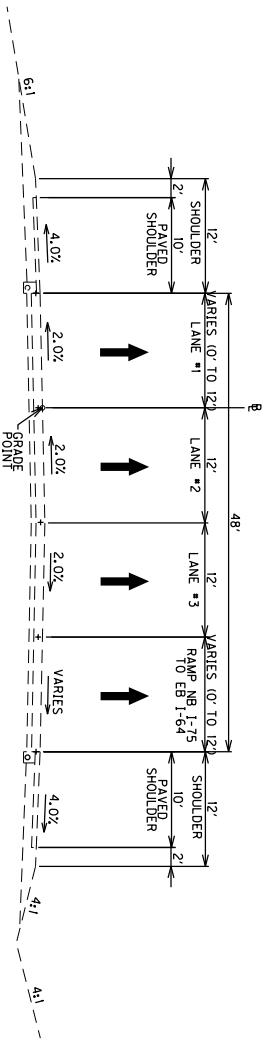

** RAMP LANE REPRESENTS THE NB I-75 RAMP TO EB I-64
" + " INDICATES LONGITUDINAL SAWED JOINT

**NORMAL 4-LANE SECTION
EB I-64 STA. 28 + 23.23 TO STA. 55 + 95.00**

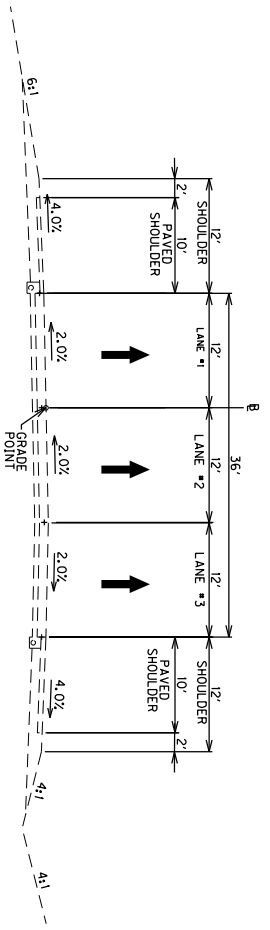

" + " INDICATES LONGITUDINAL SAWED JOINT
**NORMAL 3-LANE SECTION
EB I-64 STA. 55 + 95.00 TO I-64 STA. 82 + 20.83**

- I-64 EXISTING MAINLINE PAVEMENT STRUCTURE
- 6" DENSE GRADE AGGREGATE
- 11.0" SURFACE
- 11.0" PCC PAVEMENT, NON-REINFORCED
- 1 1/2" CL3 ASPH SURF 0.50 PG64-22
- 3" CL3 ASPH BASE 1.00 PG64-22
- 1 1/2" DENSE GRADE AGGREGATE
- 1 1/2" ASPHALT SURFACE
- 4 1/2" ASPHALT BASE
- 11" DENSE GRADE AGGREGATE

NOT TO SCALE
I-75\I-64
TYPICAL SECTIONS

COUNTY OF	ITEM NO.
FAYETTE	7-20010 & 7-20013

COUNTY OF	ITEM NO.
FAYETTE	7-20010 & 7-20013

EXISTING TYPICAL SECTIONS WESTBOUND I-64 CONCRETE SECTION

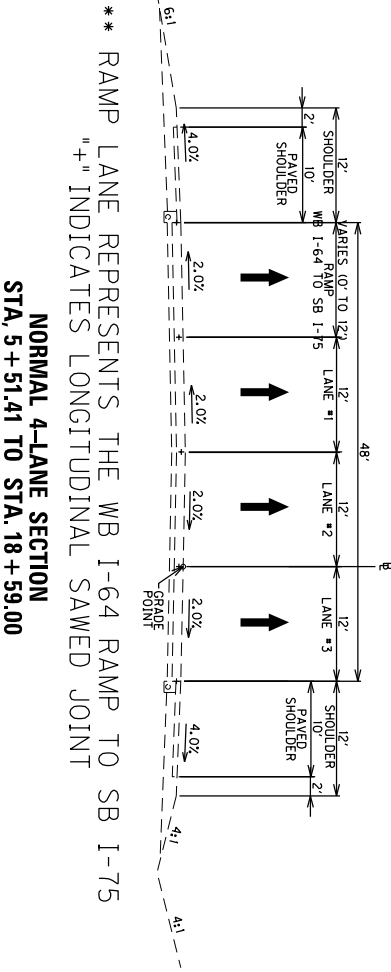
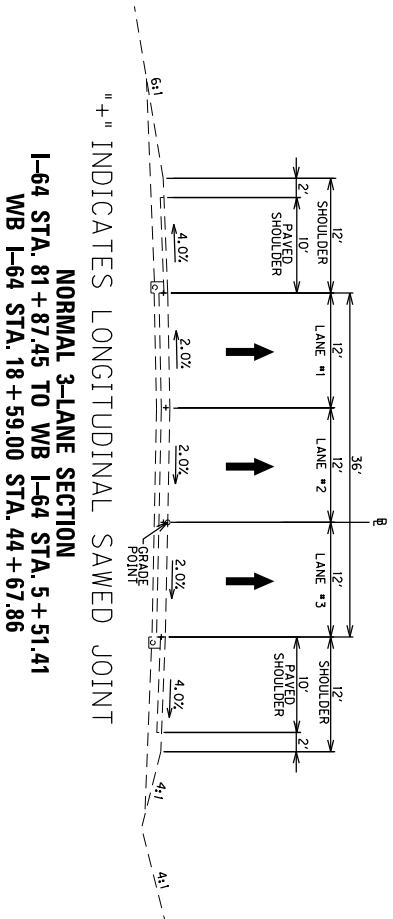

- I-64 EXISTING MAINLINE PAVEMENT STRUCTURE
- 6" DENSE GRADE AGGREGATE
- 11.0" SURFACE
- 11/2" CL 3 ASPH SURF 0.50 PG64-22
- 3" CL 3 ASPH BASE 1.00 PG64-22
- 11/2" DENSE GRADE AGGREGATE
- 11/2" ASPHALT SURFACE
- 4 1/2" ASPHALT BASE
- 11" DENSE GRADE AGGREGATE

NOT TO SCALE
 I-75\I-64
 TYPICAL SECTIONS

TYPICAL SECTIONS I-64 RAMP DETAILS

COUNTY OF	ITEM NO.
FAYETTE	7-20010 & 7-20013

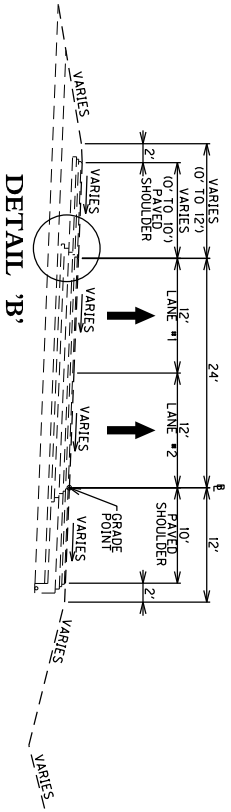

**WB I-64 TO NB I-75
2-LANE ASPHALT SECTION
WB I-64 STA. 44 + 67.86 TO STA. 57 + 70**

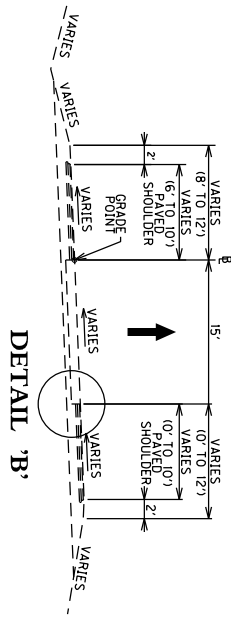

**WB I-64 TO SB I-75
1-LANE CONCRETE SECTION**

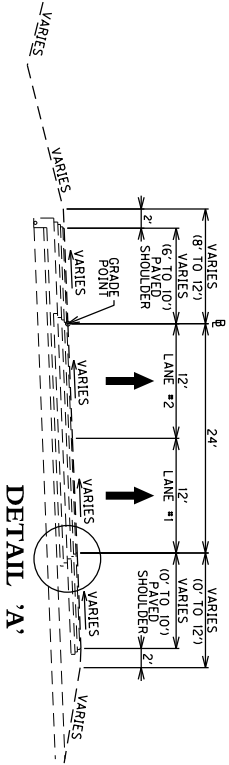

**SB I-75 TO EB I-64
2-LANE ASPHALT SECTION
EB I-64 STA. 1 + 50 TO STA. 28 + 23.23**

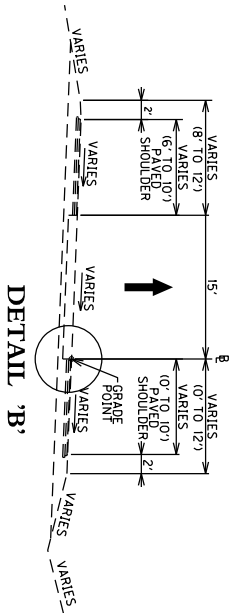

**NB I-75 TO EB I-64
1-LANE CONCRETE SECTION**

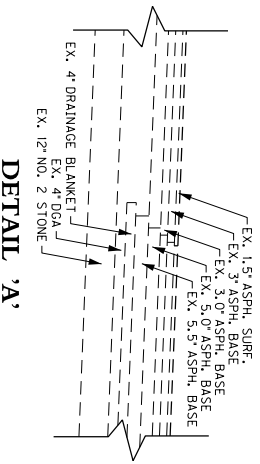

DETAIL 'A'

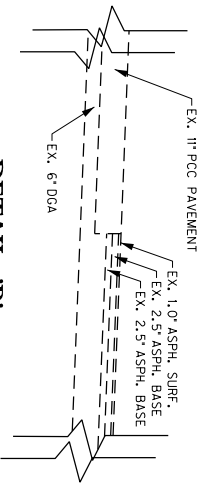

DETAIL 'B'

NOT TO SCALE

I-75\I-64
TYPICAL SECTIONS

COUNTY OF	ITEM NO.
FAYETTE	7-20010 & 7-20013

TYPICAL SECTIONS I-64 ASPHALT SECTION

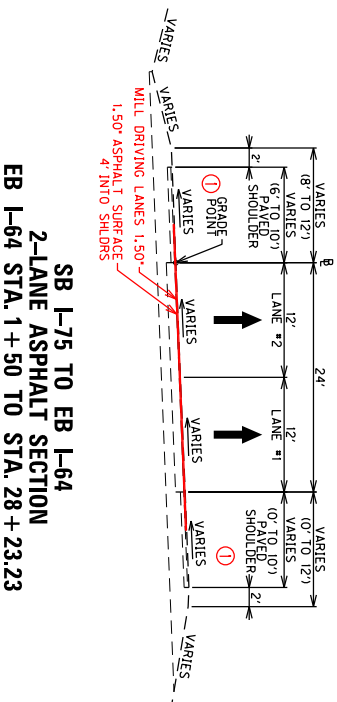
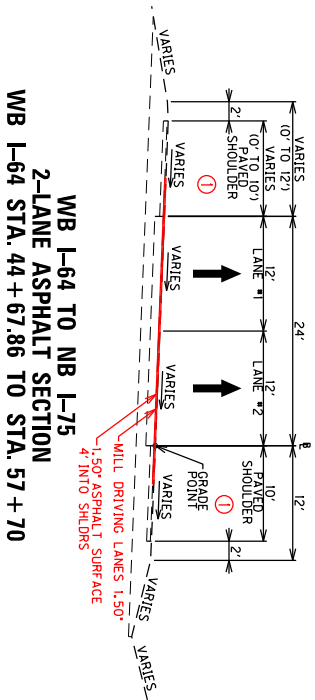

ASPHALT SECTION DRIVING LANES
1.50' ASPHALT MILLING AND TEXTURING SURFACE --- 1.50' CL4 ASPHALT SURFACE 0.384 PG76-22

① SHOULDERS ON RAMPS LESS THAN OR EQUAL TO 6' WIDE WILL BE MILLED AND SURFACED AT FULL WIDTH

NOT TO SCALE

I-75\I-64
TYPICAL SECTIONS

DETAILS I-75 INTERCHANGES

COUNTY OF	ITEM NO.
FAYETTE	7-20010 & 7-20013

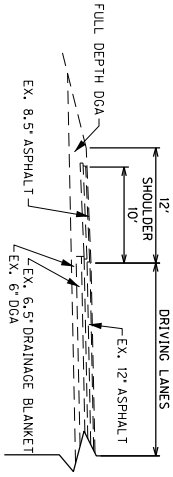

**EXISTING RAMPS
US-60**

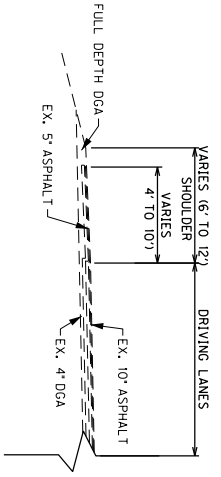

**EXISTING RAMPS
MAN O'WAR BLVD.**

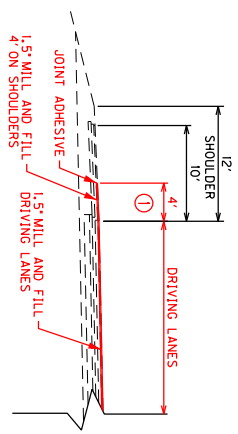

**PROPOSED RAMPS
US-60**

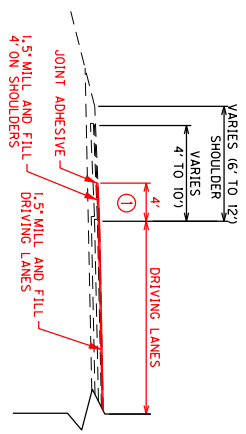

**PROPOSED RAMPS
MAN O'WAR BLVD.**

DRIVING LANES
1.50" ASPHALT MILLING AND TEXTURING
SURFACE --- 1.50" CL4 ASPHALT SURFACE 0.38A PG76-22

① SHOULDERS ON RAMPS LESS THAN OR EQUAL TO 6' WIDE WILL BE MILLED AND SURFACED AT FULL WIDTH

NOT TO SCALE
I-75-I-64
TYPICAL SECTIONS

PAVEMENT REPAIR DETAIL

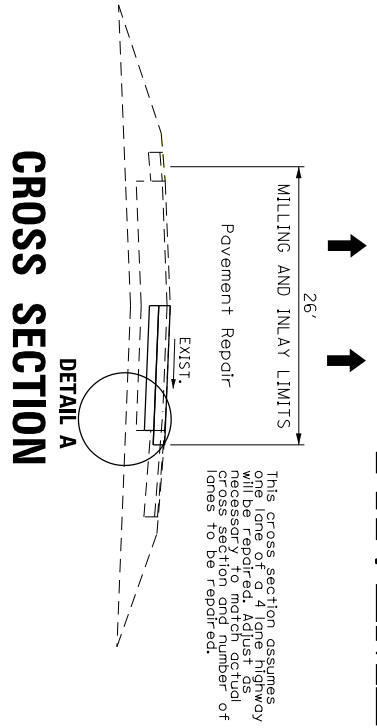

CROSS SECTION

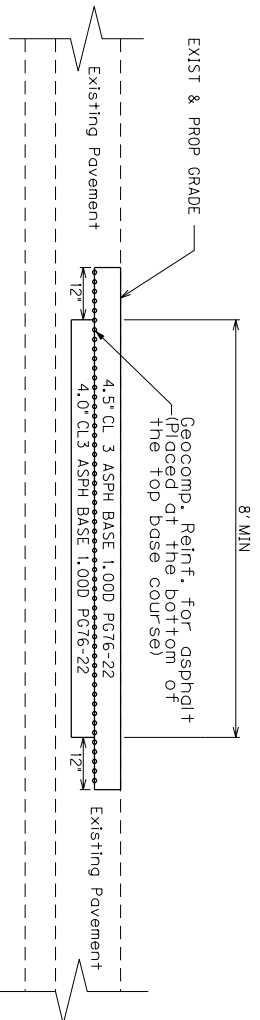

PROFILE

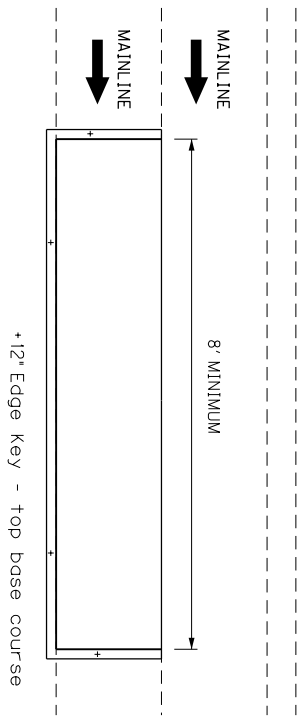

PLAN VIEW

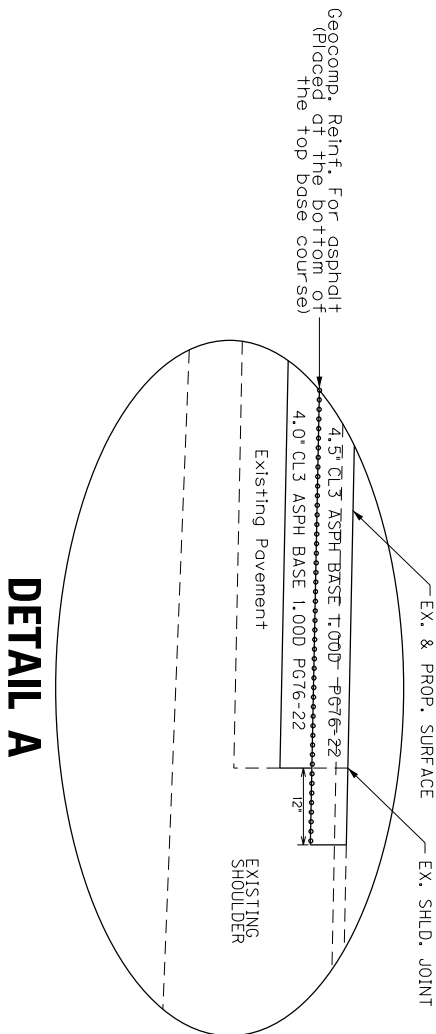

DETAIL A

NOTES

1. Caution: Existing concrete pavement may exist below the asphalt pavement.
2. Pavement repairs shall be performed at locations selected by and as directed by the Engineer. The Engineer will assess, select and mark areas for treatment. The full lane width will be removed and replaced. The Engineer may elect to perform repairs on one lane or multiple lanes. The Engineer may elect to only remove and replace the top lift of base. An edge key 12" into existing pavement is required for the top course of base.
3. Complete pavement repair operations in one continuous operation or protect with barrier wall. Do not leave an unprotected hole with no workers present. If barrier wall must be used for pavement repairs, it will be considered incidental to other items of work and not be considered for payment.
4. Before resurfacing, open repaired area to traffic for a minimum of 14 days. Monitor pavement for settlement during this 14 days and repair by leveling and wedging, as approved by the Engineer, until placement of final surface course.
5. The item REMOVE PAVEMENT includes removal of all asphalt to the required depth.
6. Perform typical mill and inlay operations with resurfacing items subject to payment as part of the resurfacing operation.

*** QUANTITIES TO BID**

02091 REMOVE PAVEMENT	SQ. YD.
25010EC GEOCOMPOSITE REINFORCEMENT FOR ASPHALT	SQ. YD.
0216 CL3 ASPH BASE 1,000 PG76-22	TON

* Only items listed will be considered for payment and will be considered full compensation for the work required. Any other items of work not listed for payment will be considered incidental to other items of work.

Asph base course class and binder grade to be chosen by designer based on current asphalt warrants and/or to remain consistent with mainline asphalt surface used on the project.

NOT TO SCALE

1-751-64
DETAIL SHEET

COUNTY OF	ITEM NO.
FAYETTE	7-20010 & 7-20013

COUNTY OF	ITEM NO.
FAYETTE	7-20010 & 7-20013

CROSS SECTION VIEW

CONCRETE WEDGE CURB

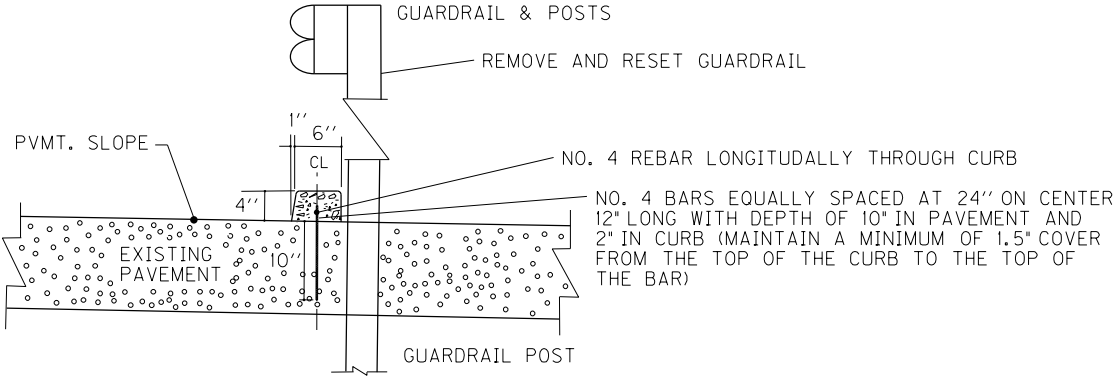

NOT TO SCALE

PLAN VIEW

CONCRETE WEDGE CURB

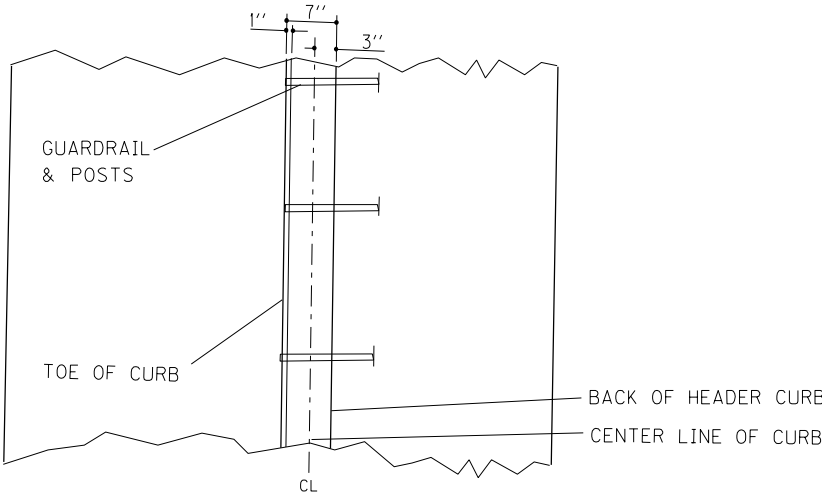

NOT TO SCALE

DETAIL SHEET

I-64 STATIONING REFERENCES	
EASTBOUND I-64	
STATION	FEATURE
2+97	OVERHEAD TRUSS SIGN
28+10	HUME ROAD BRIDGE
28+24	ASPHALT / CONCRETE TRANSITION
52+44	MILEPOST 82.0
58+96.09	EQUATION 58+96.10 BK = 79+00.00 AH
81+92	CONCRETE / ASPHALT TRANSITION LANE 1
82+21	CONCRETE / ASPHALT TRANSITION LANES 2 AND 3
82+48	MILEPOST 82.2
WESTBOUND I-64	
STATION	FEATURE
82+48	MILEPOST 82.2
81+87.45	ASPHALT / CONCRETE TRANSITION
79+00.00	EQUATION 79+00.00 BK = 0+00.00 AH
6+61	MILEPOST 82.0
18+45	OVERHEAD TRUSS SIGN
34+23	HUME ROAD BRIDGE
44+68	CONCRETE / ASPHALT TRANSITION
NB I-75 TO EB I-64 RAMP	
STATION	FEATURE
2+56	OVERHEAD TRUSS SIGN
5+87	ASPHALT / CONCRETE TRANSITION
31+77	HUME ROAD BRIDGE
39+00	END PAINTED GORE
WB I-64 TO SB I-75 RAMP	
STATION	FEATURE
2+84	OVERHEAD TRUSS SIGN
2+94	BEGIN PAINTED GORE
16+72	HUME ROAD BRIDGE
24+27	BEGIN BRIDGE OVER SB I-75 TO EB I-64 RAMP
26+49	END BRIDGE OVER SB I-75 TO EB I-64 RAMP
53+46	CONCRETE / ASPHALT TRANSITION

**I-64 & I-75 PAVEMENT REHABILITATION
FAYETTE COUNTY
ITEM NUMBERS: 7-20010.00 & 7-20013.00
GENERAL SUMMARY**

ITEM NUMBER	ITEM		7-20010 I-64	7-20013 I-75	PROJECT TOTAL	UNIT
1	DGA BASE	(1)	100	300	400	TON
78	CRUSHED AGGREGATE SIZE NO. 2	(8)	10	40	50	TON
194	LEVELING AND WEDGING PG 76-22	(1)	10	500	510	TON
216	CL3 ASPH BASE 1.00D PG76-22	(8)	18	243	261	TON
342	CL 4 ASPH SURF 0.38A PG 76-22		1,310	23,771	25,081	TON
356	ASPHALT MATERIAL FOR TACK		7	121	128	TON
461	CULVERT PIPE 15 INCH		0	4	4	LIN FT
1000	PERFORATED PIPE - 4 INCH	(1)	100	200	300	LIN FT
1010	NON-PERFORATED PIPE - 4 INCH	(1)(11)	20	40	60	LIN FT
1020	PERFORATED PIPE HEADWALL TYPE 1 - 4 INCH	(1)	1	2	3	EACH
1028	PERFORATED PIPE HEADWALL TYPE 3 - 4 INCH	(1)(11)	1	2	3	EACH
1202	PIPE CULVERT HEADWALL - 15 INCH		0	1	1	EACH
1484	CURB BOX INLET TYPE B-T		0	1	1	EACH
1691	FLUME INLET TYPE 2	(14)	1	6	7	EACH
1984	DELINEATOR FOR BARRIER - WHITE		0	44	44	EACH
1985	DELINEATOR FOR BARRIER - YELLOW		12	290	302	EACH
2058	REMOVE PCC PAVEMENT	(2)	2,611	0	2,611	SQ YD
2060	PCC PAVEMENT DIAMOND GRINDING		47,774	0	47,774	SQ YD
2071	JPC PAVEMENT - 11IN	(2)	2,611	0	2,611	SQ YD
2091	REMOVE PAVEMENT	(8)	38	519	557	SQ YD
2115	SAW-CLEAN-RESEAL TRANSVERSE JOINT		56,577	0	56,577	LIN FT
2116	SAW-CLEAN-RESEAL LONGITUDINAL JOINT		51,860	0	51,860	LIN FT
2220	FLOWABLE FILL	(1)(13)	2	8	10	CU YD
2237	DITCHING		6,088	23,744	29,832	LIN FT
2351	GUARDRAIL-STEEL 'W' BEAM-S FACE		0	175	175	LIN FT
2369	GUARDRAIL END TREATMENT TYPE 2A		0	1	1	EACH
2383	REMOVE AND RESET GUARDRAIL		200	1,762	1,962	LIN FT
2387	GUARDRAIL CONNECTOR TO BRIDGE END TY A-1		0	1	1	EACH
2483	CHANNEL LINING CLASS II	(3)	10	115	125	TON
2484	CHANNEL LINING CLASS III	(3)	3	75	78	TON
2562	TEMPORARY SIGNS		2,500	5,000	7,500	SQ FT
2568	MOBILIZATION		1	1	1	LS
2569	DEMOBILIZATION		1	1	1	LS
2602	FABRIC-GEOTEXTILE CLASS 1	(8)	100	100	200	SQ YD
2604	FABRIC - GEOTEXTILE CLASS 1A	(8)	100	100	200	SQ YD
2650	MAINTAIN AND CONTROL TRAFFIC		1	1	1	LS
2671	PORTABLE CHANGEABLE MESSAGE SIGN	(4)	0	6	6	EACH
2676	MOBILIZATION FOR MILLING & TEXTURING		1	1	1	LS
2677	ASPHALT PAVE MILLING & TEXTURING	(10)	1,310	23,771	25,081	TON
2701	TEMPORARY SILT FENCE	(1)	100	200	300	LIN FT
2775	ARROW PANEL	(4)	4	8	12	EACH
5950	EROSION CONTROL BLANKET	(1)	100	400	500	SQ YD
5964	MAINTENANCE FERTILIZER	(1)	1	4	5	TON
5985	SEEDING AND PROTECTION	(1)	100	200	300	SQ YD
6401	FLEXIBLE DELINEATOR POST-M/W		306	846	1,152	EACH
6404	FLEXIBLE DELINEATOR POST-M/Y		288	342	630	EACH
6412	STEEL POST MILE MARKERS		2	8	10	EACH
6511	PAVEMENT STRIPING-TEMP PAINT - 6 INCH		49,196	151,793	200,989	LIN FT
6542	PAVE STRIPING THERMO - 6 INCH WHITE		4,888	87,016	91,904	LIN FT
6543	PAVE STRIPING THERMO - 6 INCH YELLOW		3,398	55,407	58,805	LIN FT
6546	PAVE STRIPING THERMO - 12 INCH WHITE	(5)	3,733	5,824	9,557	LIN FT
6556	PAVE STRIPING DUR TY 1 - 6 INCH WHITE		19,803	2,136	21,939	LIN FT
6557	PAVE STRIPING DUR TY 1 - 6 INCH YELLOW		15,703	1,410	17,113	LIN FT
6560	PAVE STRIPING DUR TY 1 - 12 INCH WHITE		1,671	0	1,671	LIN FT
6568	PAVE MARKING-THERMO STOP BAR-24IN		0	110	110	LIN FT
6574	PAVE MARKING-THERMO CURV ARROW		0	42	42	EACH
6578	PAVE MARKING-THERMO MERGE ARROW		6	6	12	EACH
6592	PAVEMENT MARKER TYPE V-B W/R	(9)	251	0	251	EACH
6593	PAVEMENT MARKER TYPE V-B Y/R	(9)	198	0	198	EACH

I-64 & I-75 PAVEMENT REHABILITATION FAYETTE COUNTY ITEM NUMBERS: 7-20010.00 & 7-20013.00 GENERAL SUMMARY						
ITEM NUMBER	ITEM		7-20010 I-64	7-20013 I-75	PROJECT TOTAL	UNIT
6600	REMOVE PAVEMENT MARKER TYPE V	(9)	449	0	449	EACH
6613	INLAID PAVEMENT MARKER - B W/R		140	1,258	1,398	EACH
6614	INLAID PAVEMENT MARKER - B Y/R		44	110	154	EACH
10020NS	FUEL ADJUSTMENT		390	33,514	33,904	DOLLARS
10030NS	ASPHALT ADJUSTMENT		0	59,058	59,058	DOLLARS
20071EC	JOINT ADHESIVE		12,050	227,129	239,179	LIN FT
20362ES403	SHOULDER RUMBLE STRIPS SAWED	(6)	0	19,590	19,590	LIN FT
20366NN	REPLACE GRATE		1	7	8	EACH
20411ED	LAW ENFORCEMENT OFFICER		250	200	450	HOURL
21173EC	SAW-CLEAN-RESEAL RANDOM CRACKS	(2)	158	0	158	LIN FT
22883EN	CONCRETE WEDGE CURB	(12)	200	1,737	1,937	LIN FT
22664EN	WATER BLASTING EXISTING STRIPE		49,196	151,793	200,989	LIN FT
20430ED	SAW CUT (RUMBLE STRIPE)		6,981	90,365	97,346	LIN FT
24891EC	PAVE MOUNT INFRARED TEMP EQUIPMENT		142,947	2,593,206	2,736,153	SQ FT
24683ED	PAVE MARKING - THERMO DOTTED LANE EXTENSION		0	1,053	1,053	LIN FT
24679ED	PAVE MARK THERMO CHEVRON		2,603	2,092	4,695	SQ FT
24899EC	PAVE MARKING - THERMO ELONG ROUTE SHIELD	(7)	0	14	14	EACH
24997EC	PARTIAL DEPTH PATCHING-POLYMER MOD	(2)	178	0	178	CU FT
25010EC	GEOCOMPOSITE REINFORCEMENT FOR ASPHALT	(8)	38	519	557	SQ YD
25075EC	QUEUE PROTECTION VEHICLE		480	960	1,440	HOURL
25117EC	FURNISH QUEUE PROTECTION VEHICLES		3	6	9	MONTH
26136EC	PORTABLE QUEUE WARNING ALERT SYSTEM		3	6	9	MONTH
26137EC	QUEUE WARNING PCMS		12	24	36	MONTH
26138EC	QUEUE WARNING PORTABLE RADAR SENSORS		12	24	36	MONTH

- (1) To be used as directed by the Engineer.
- (2) Includes ten percent additional removal and replacement for continuing deterioration of the existing pavement.
- (3) Any excavation and Fabric-Geotextile Class 2 required to place the Class III channel lining is incidental to the lining.
- (4) The quantity for these items includes initial placement. Any relocation required will not be paid for directly, but will be considered incidental to maintain and control traffic.
- (5) Includes 167 linear feet for optional lane use arrows. See Standard Drawing TPM-202 for details.
- (6) For the Man O' War and US 60 Winchester road ramps.
- (7) See plan sheets for locations.
- (8) To be used as directed by the Engineer for full depth concrete pavement repairs, and asphalt pavement repairs.
- (9) To be used on concrete pavement only.
- (10) Removal of existing pavement markers on asphalt will be considered incidental to Milling and Texturing.
- (11) Includes items carried over from the drainage summary. The remainder is to be used as directed by the Engineer.
- (12) Includes 25 LF of Concrete Wedge Curb to be installed with Connector to bridge end type A-1.
- (13) The total for I-75 includes 3 tons from the drainage summary. The remainder is to be used as directed by the Engineer.
- (14) Approximate locations are shown on the drainage summary. Actual locations are to be as directed by the Engineer.

I-75 PAVING SUMMARY				
	CODE	ITEM	UNITS	TOTAL
(3)	25010EC	GEOCOMPOSITE REINFORCEMENT FOR ASPHALT	SQ. YD.	519
(3)	216	CL3 ASPH BASE 1.00D PG76-22	TON	243
(1)	342	CL4 ASPH SURF 0.38A PG76-22	TON	23771
(2)	356	ASPHALT MATERIAL FOR TACK	TON	121
(3)	2091	REMOVE PAVEMENT	SQ. YD.	519
	2677	ASPHALT PAVE MILLING & TEXTURING	TON	23771
	24891EC	PAVE MOUNT INFRARED TEMP EQUIPMENT	SQ FT	2593206
I-64 PAVING SUMMARY				
	CODE	ITEM	UNITS	TOTAL
(3)	25010EC	GEOCOMPOSITE REINFORCEMENT FOR ASPHALT	SQ. YD.	38
(3)	216	CL3 ASPH BASE 1.00D PG76-22	TON	18
(1)	342	CL4 ASPH SURF 0.38A PG76-22	TON	1310
(2)	356	ASPHALT MATERIAL FOR TACK	TON	7
(3)	2091	REMOVE PAVEMENT	SQ. YD.	38
	2677	ASPHALT PAVE MILLING & TEXTURING	TON	1310
	24891EC	PAVE MOUNT INFRARED TEMP EQUIPMENT	SQ FT	142947
NOTES				
(1)	ALL ASPHALT MIXTURES ESTIMATED AT 110 LBS. PER SQ. YD. PER INCH OF DEPTH			
(2)	ASPHALT MATERIAL FOR TACK ESTIMATED AT 0.84 LBS. PER SQ. YD			
(3)	FOR PAVEMENT REPAIRS AS DIRECTED BY THE ENGINEER.			
QUANTITIES HAVE BEEN CARRIED OVER AND INCLUDED IN THE GENERAL SUMMARY				

I-75 PAVING SUMMARY				
	CODE	ITEM	UNITS	TOTAL
(3)	20263ED	GEOGRID REINFORCEMENT	SQ. YD.	519
(3)	216	CL3 ASPH BASE 1.00D PG76-22	TON	243
(1)	342	CL4 ASPH SURF 0.38A PG76-22	TON	23771
(2)	356	ASPHALT MATERIAL FOR TACK	TON	121
(3)	2091	REMOVE PAVEMENT	SQ. YD.	519
	2677	ASPHALT PAVE MILLING & TEXTURING	TON	23771
	24891EC	PAVE MOUNT INFRARED TEMP EQUIPMENT	SQ FT	2593206
I-64 PAVING SUMMARY				
	CODE	ITEM	UNITS	TOTAL
(3)	20263ED	GEOGRID REINFORCEMENT	SQ. YD.	38
(3)	216	CL3 ASPH BASE 1.00D PG76-22	TON	18
(1)	342	CL4 ASPH SURF 0.38A PG76-22	TON	1310
(2)	356	ASPHALT MATERIAL FOR TACK	TON	7
(3)	2091	REMOVE PAVEMENT	SQ. YD.	38
	2677	ASPHALT PAVE MILLING & TEXTURING	TON	1310
	24891EC	PAVE MOUNT INFRARED TEMP EQUIPMENT	SQ FT	142947
NOTES				
(1)	ALL ASPHALT MIXTURES ESTIMATED AT 110 LBS. PER SQ. YD. PER INCH OF DEPTH			
(2)	ASPHALT MATERIAL FOR TACK ESTIMATED AT 0.84 LBS. PER SQ. YD			
(3)	FOR PAVEMENT REPAIRS AS DIRECTED BY THE ENGINEER.			
QUANTITIES HAVE BEEN CARRIED OVER AND INCLUDED IN THE GENERAL SUMMARY				

**I-75 & I-64 PAVEMENT REHABILITATION
FAYETTE COUNTY
ITEM NO: 7-20010.00 & 7-20013.00
DIAMOND GRINDING SUMMARY**

DIRECTION	NUMBER OF LANES	BEGIN STATION	END STATION	LINEAR LANE-FEET	SQUARE YARDS
EASTBOUND I-64					
I-64 EB	2 TO 3	28+23	32+42	419	1,397
I-64 EB	3	32+42	35+75	333	1,332
I-64 EB	4	35+75	50+52	1,477	7,877
I-64 EB	4 TO 3	50+52	55+20	468	2,184
I-64 EB	3	55+20	58+96.09	376	1,504
STATION EQUATION 58+96.10 BACK = STATION 79+00.00 AHEAD					
I-64 EB	3	79+00	81+92	292	1,168
I-64 EB	2	81+92	82+21	29	77
WESTBOUND I-64					
I-64 WB	3	79+00.00	81+87.45	287	1,150
STATION EQUATION 79+00.00 BACK = STATION 0+00.00 AHEAD					
I-64 WB	3	0+00.00	5+50	550	2,200
I-64 WB	3 TO 4	5+50	8+50	300	1,400
I-64 WB	4	8+50	18+60	1,010	5,387
I-64 WB	3	18+60	35+20	1,660	6,640
I-64 WB	3 TO 2	35+20	44+67.86	948	3,160
WESTBOUND I-64 TO SOUTHBOUND I-75					
I-64 WB	1	2+94	24+14.00	2120	3,533
I-64 WB	1	26+42	53+46.00	2704	4,507
NORTHBOUND I-75 TO EASTBOUND I-64					
I-64 EB	1	5+87	37+81.00	3,194	4,259
TOTAL PCC PAVEMENT DIAMOND GRINDING (SQYD)				47,774	
Note: Lanes are based on the number of concrete lanes and their widths, NOT the striped lanes.					
Note: Quantities are carried over to the General Summary					

**I-75 & I-64 PAVEMENT REHABILITATION
FAYETTE COUNTY
ITEM NO: 7-20010.00 & 7-20013.00
CONCRETE FULL DEPTH REPAIR SUMMARY**

BEGIN STATION	END STATION	LENGTH (FT)	LANE #1	LANE #2	LANE #3	TOTAL SQ YD JPC - 11"	COMMENTS
SB I-75 TO EB I-64							
28+80	28+99	19	X			25	12' WIDE
29+53	29+63	10	X			13	12' WIDE
32+88	35+35	247			X	329	12' WIDE
36+79	36+97	18		X		24	12' WIDE
37+86	39+17	131			X	175	12' WIDE
47+29	47+51	22			X	29	12' WIDE
57+84	58+42	58		X		77	12' WIDE
57+84	58+31	47			X	63	12' WIDE
STATION EQUATION SB I-75 TO EB I-64 BACK STA. 58+96.09 = I-64 AHD STA. 79+00.00							
58+86	79+36	46		X		61	12' WIDE
58+86	79+54	64			X	85	12' WIDE
WESTBOUND I-64 TO NB I-75							
0+10	0+16	6		X		8	12' WIDE
0+39	1+05	66	X			88	12' WIDE
1+70	1+77	7		X		9	12' WIDE
6+68	6+74	6		X		8	12' WIDE
6+68	6+74	6			X	8	12' WIDE
8+19	8+36	17	X			23	12' WIDE
8+66	8+97	31		X		41	12' WIDE
9+26	9+92	66		X		88	12' WIDE
10+88	12+56	168		X		224	12' WIDE
11+04	11+96	92	X			123	12' WIDE
14+36	14+47	11	X			15	12' WIDE
18+48	19+63	115		X		153	12' WIDE
20+75	22+48	173		X		231	12' WIDE
23+02	23+50	48	X			64	12' WIDE
22+85	23+50	65		X		87	12' WIDE
24+64	24+98	34		X		45	12' WIDE
27+19	27+84	65		X		87	12' WIDE
NORTHBOUND I-75 TO EB I-64							
6+16	6+34	18	X			30	15' WIDE
6+76	6+94	18	X			30	15' WIDE
20+46	20+49	3	X			5	15' WIDE
21+52	21+75	23	X			39	15' WIDE
30+91	30+99	8	X			13	15' WIDE
31+08	31+18	10	X			17	15' WIDE
35+23	35+32	9	X			15	15' WIDE
35+43	35+54	11	X			18	15' WIDE
WESTBOUND I-64 TO SOUTHBOUND I-75							
26+87	27+07	20	SHLDR			4	2' WIDE
31+05	31+11	6	X			10	15' WIDE
31+20	31+26	6	X			10	15' WIDE
EASTBOUND I-64 TOTAL - JPC PAVEMENT 11 IN (SQ YD)						881	
WESTBOUND I-64 TOTAL - JPC PAVEMENT 11 IN (SQ YD)						1,302	
NORTHBOUND I-75 TO EASTBOUND I-64 - JPC PAVEMENT 11 IN (SQ YD)						167	
WESTBOUND I-64 TO SOUTHBOUND I-75 - JPC PAVEMENT 11 IN (SQ YD)						24	
PROJECT TOTAL - JPC PAVEMENT 11 IN (SQ YD)						2,374	
<i>Lane numbers begin with the left most driving lane slabs (lane #1) and increase as you move right into the right most slabs. Note that shoulders and turn lanes were noted directly. (Each Direction Separately)</i>							
<i>Approximate full depth pavement repair locations are listed in this proposal. The Engineer will determine the exact location at the time of construction.</i>							
<i>Note: Quantities are carried over to the General Summary</i>							

**I-75 & I-64 PAVEMENT REHABILITATION
FAYETTE COUNTY
ITEM NO: 7-20010.00 & 7-20013.00
PARTIAL DEPTH PCC PAVEMENT REPAIRS**

STATION	INSIDE SHOULDER	LANE #0	LANE #1	LANE #2	LANE #3	LANE #4	OUTSIDE SHOULDER	APPROX. SURF. AREA (SQ FT)	DEPTH (FT)	PARTIAL DEPTH PATCHING (CU FT)	SAW-CLEAN-RESEAL RANDOM CRACKS (LF)
EASTBOUND I-64											
28+31				X							12
28+52				X				2	0.28	0.56	
28+83				X				2	0.28	0.56	
29+32			X					2	0.28	0.56	
30+76				X				3	0.28	0.84	
31+23				X				1	0.28	0.28	
31+53			X					1	0.28	0.28	
32+42		X						1	0.28	0.28	
33+16				X				1	0.28	0.28	
33+50				X				1	0.28	0.28	
33+63				X				1	0.28	0.28	
33+76				X				1	0.28	0.28	
33+93				X				1	0.28	0.28	
34+10				X				2	0.28	0.56	
34+54				X				2	0.28	0.56	
34+72				X				2	0.28	0.56	
34+90				X				1	0.28	0.28	
35+15				X				2	0.28	0.56	
35+61					X			1	0.28	0.28	
35+74					X			2	0.28	0.56	
35+92					X			2	0.28	0.56	
36+09					X			2	0.28	0.56	
36+34					X			2	0.28	0.56	
36+34				X				2	0.28	0.56	
36+34						X		1	0.28	0.28	
36+52					X			2	0.28	0.56	
36+70						X		1	0.28	0.28	
37+11						X		2	0.28	0.56	
37+41						X		2	0.28	0.56	
37+54						X		1	0.28	0.28	
37+71				X				2	0.28	0.56	
37+89				X				2	0.28	0.56	
38+14				X				2	0.28	0.56	
38+32				X				1	0.28	0.28	

**I-75 & I-64 PAVEMENT REHABILITATION
FAYETTE COUNTY
ITEM NO: 7-20010.00 & 7-20013.00
PARTIAL DEPTH PCC PAVEMENT REPAIRS**

STATION	INSIDE SHOULDER	LANE #0	LANE #1	LANE #2	LANE #3	LANE #4	OUTSIDE SHOULDER	APPROX. SURF. AREA (SQ FT)	DEPTH (FT)	PARTIAL DEPTH PATCHING (CU FT)	SAW-CLEAN-RESEAL RANDOM CRACKS (LF)
38+49			X					1	0.28	0.28	
38+49				X				1	0.28	0.28	
38+75				X				1	0.28	0.28	
38+91				X				3	0.28	0.84	
39+09				X				3	0.28	0.84	
39+34			X					1	0.28	0.28	
42+34						X		1	0.28	0.28	
44+14						X		2	0.28	0.56	
44+31						X		1	0.28	0.28	
44+61						X		3	0.28	0.84	
45+60				X							12
45+93				X				3	0.28	0.84	
45+93						X		1	0.28	0.28	
47+99					X						12
48+09						X		1	0.28	0.28	
48+34						X		1	0.28	0.28	
51+68						X		1	0.28	0.28	
52+11						X		1	0.28	0.28	
53+13						X		3	0.28	0.84	
STATION EQUATION 58+96.10 BACK = STATION 79+00.00 AHEAD											
79+51				X				1	0.28	0.28	
79+77					X			4	0.28	1.12	
79+94				X				2	0.28	0.56	
79+94					X			2	0.28	0.56	
80+11				X				2	0.28	0.56	
80+11					X			3	0.28	0.84	
80+23					X			4	0.28	1.12	
80+37					X			4	0.28	1.12	
80+53					X			4	0.28	1.12	
80+96					X			2	0.28	0.56	
WESTBOUND I-64											
81+81			X								12
81+57				X				1	0.28	0.28	
81+45				X				3	0.28	0.84	
81+28				X				1	0.28	0.28	

**I-75 & I-64 PAVEMENT REHABILITATION
FAYETTE COUNTY
ITEM NO: 7-20010.00 & 7-20013.00
PARTIAL DEPTH PCC PAVEMENT REPAIRS**

STATION	INSIDE SHOULDER	LANE #0	LANE #1	LANE #2	LANE #3	LANE #4	OUTSIDE SHOULDER	APPROX. SURF. AREA (SQ FT)	DEPTH (FT)	PARTIAL DEPTH PATCHING (CU FT)	SAW-CLEAN-RESEAL RANDOM CRACKS (LF)
80+97				X				2	0.28	0.56	
80+97			X					1	0.28	0.28	
80+86			X					1	0.28	0.28	
80+86				X				1	0.28	0.28	
80+67			X					2	0.28	0.56	
80+67				X				2	0.28	0.56	
80+50			X					2	0.28	0.56	
80+50				X				2	0.28	0.56	
80+37				X				1	0.28	0.28	
80+26				X				1	0.28	0.28	
80+07				X				2	0.28	0.56	
79+78			X					1	0.28	0.28	
79+66			X					2	0.28	0.56	
79+47			X					2	0.28	0.56	
79+47				X				2	0.28	0.56	
79+30			X					4	0.28	1.12	
79+30				X				1	0.28	0.28	
79+17			X					1	0.28	0.28	
79+17				X				1	0.28	0.28	
79+05			X					1	0.28	0.28	
79+06				X				1	0.28	0.28	
STATION EQUATION 79+00.00 BACK = STATION 0+00.00 AHEAD											
1+14					X			1	0.28	0.28	
1+92				X				1	0.28	0.28	
2+09				X				2	0.28	0.56	
2+34				X				3	0.28	0.84	
3+89					X			1	0.28	0.28	
4+02				X				2	0.28	0.56	
4+14				X				4	0.28	1.12	
4+32				X				2	0.28	0.56	
4+49				X				1	0.28	0.28	
4+74				X				1	0.28	0.28	
5+09				X				1	0.28	0.28	
5+22				X				3	0.28	0.84	
5+52			X					2	0.28	0.56	

**I-75 & I-64 PAVEMENT REHABILITATION
FAYETTE COUNTY
ITEM NO: 7-20010.00 & 7-20013.00
PARTIAL DEPTH PCC PAVEMENT REPAIRS**

STATION	INSIDE SHOULDER	LANE #0	LANE #1	LANE #2	LANE #3	LANE #4	OUTSIDE SHOULDER	APPROX. SURF. AREA (SQ FT)	DEPTH (FT)	PARTIAL DEPTH PATCHING (CU FT)	SAW-CLEAN-RESEAL RANDOM CRACKS (LF)
5+52				X				2	0.28	0.56	
5+69			X					4	0.28	1.12	
5+82			X					4	0.28	1.12	
5+94			X					2	0.28	0.56	
6+42		X						1	0.28	0.28	
6+42				X				1	0.28	0.28	
6+53		X						2	0.28	0.56	
7+01		X						1	0.28	0.28	
7+01			X					1	0.28	0.28	
7+01				X				1	0.28	0.28	
7+13			X					1	0.28	0.28	
7+13			X					2	0.28	0.56	
7+32				X				1	0.28	0.28	
7+49				X				2	0.28	0.56	
7+62			X					2	0.28	0.56	
7+62				X				1	0.28	0.28	
7+74			X					2	0.28	0.56	
7+74				X				1	0.28	0.28	
7+92			X					2	0.28	0.56	
7+92				X				1	0.28	0.28	
8+08			X					1	0.28	0.28	
8+08				X				2	0.28	0.56	
8+08					X			1	0.28	0.28	
8+22				X				1	0.28	0.28	
8+69			X					3	0.28	0.84	
8+82			X					1	0.28	0.28	
9+12			X					2	0.28	0.56	
9+29		X						1	0.28	0.28	
9+54		X						2	0.28	0.56	
9+72		X						1	0.28	0.28	
9+89		X						1	0.28	0.28	
10+01				X				1	0.28	0.28	
10+14		X						2	0.28	0.56	
10+14			X					1	0.28	0.28	
10+31			X					3	0.28	0.84	

**I-75 & I-64 PAVEMENT REHABILITATION
FAYETTE COUNTY
ITEM NO: 7-20010.00 & 7-20013.00
PARTIAL DEPTH PCC PAVEMENT REPAIRS**

STATION	INSIDE SHOULDER	LANE #0	LANE #1	LANE #2	LANE #3	LANE #4	OUTSIDE SHOULDER	APPROX. SURF. AREA (SQ FT)	DEPTH (FT)	PARTIAL DEPTH PATCHING (CU FT)	SAW-CLEAN-RESEAL RANDOM CRACKS (LF)
10+49			X					1	0.28	0.28	
10+62			X					1	0.28	0.28	
11+08		X						1	0.28	0.28	
11+21		X						2	0.28	0.56	
11+34		X						2	0.28	0.56	
11+52		X						2	0.28	0.56	
12+11		X						1	0.28	0.28	
12+53		X						3	0.28	0.84	
13+02			X					3	0.28	0.84	
13+02				X				2	0.28	0.56	
13+14			X					3	0.28	0.84	
13+32		X						1	0.28	0.28	
13+49			X					3	0.28	0.84	
13+73			X					2	0.28	0.56	
13+91		X						2	0.28	0.56	
13+91			X					1	0.28	0.28	
14+09		X						2	0.28	0.56	
14+09			X					1	0.28	0.28	
14+51				X				4	0.28	1.12	
14+93		X						1	0.28	0.28	
15+11		X						1	0.28	0.28	
16+73				X				2	0.28	0.56	
16+91				X				2	0.28	0.56	
17+67					X			2	0.28	0.56	
18+27				X				1	0.28	0.28	
18+27					X			2	0.28	0.56	
20+19			X					1	0.28	0.28	
20+31			X					1	0.28	0.28	
20+31				X				1	0.28	0.28	
20+49			X					3	0.28	0.84	
20+49				X				3	0.28	0.84	
20+91			X					2	0.28	0.56	
22+70			X					3	0.28	0.84	
23+64				X				1	0.28	0.28	
23+89				X				1	0.28	0.28	

**I-75 & I-64 PAVEMENT REHABILITATION
FAYETTE COUNTY
ITEM NO: 7-20010.00 & 7-20013.00
PARTIAL DEPTH PCC PAVEMENT REPAIRS**

STATION	INSIDE SHOULDER	LANE #0	LANE #1	LANE #2	LANE #3	LANE #4	OUTSIDE SHOULDER	APPROX. SURF. AREA (SQ FT)	DEPTH (FT)	PARTIAL DEPTH PATCHING (CU FT)	SAW-CLEAN-RESEAL RANDOM CRACKS (LF)
24+07			X					2	0.28	0.56	
24+36				X				2	0.28	0.56	
24+56			X					1	0.28	0.28	
24+67			X					1	0.28	0.28	
24+90					X			2	0.28	0.56	
25+67				X				2	0.28	0.56	
25+85				X				2	0.28	0.56	
26+02			X					2	0.28	0.56	
26+02				X				2	0.28	0.56	
26+27				X				2	0.28	0.56	
26+74				X				4	0.28	1.12	
26+86				X				2	0.28	0.56	
27+46			X					2	0.28	0.56	
27+64			X					2	0.28	0.56	
27+81			X					1	0.28	0.28	
27+94			X					1	0.28	0.28	
28+06					X			2	0.28	0.56	
28+23			X					1	0.28	0.28	
28+23				X				1	0.28	0.28	
28+41			X					1	0.28	0.28	
28+41				X				1	0.28	0.28	
28+53			X					2	0.28	0.56	
28+53				X				2	0.28	0.56	
28+83				X				1	0.28	0.28	
29+00			X					1	0.28	0.28	
29+00				X				1	0.28	0.28	
29+12			X					1	0.28	0.28	
29+13				X				1	0.28	0.28	
29+24			X					1	0.28	0.28	
29+59			X					1	0.28	0.28	
29+66				X				3	0.28	0.84	
29+72			X					1	0.28	0.28	
29+72				X				3	0.28	0.84	
29+85			X					1	0.28	0.28	
30+19			X					1	0.28	0.28	

**I-75 & I-64 PAVEMENT REHABILITATION
FAYETTE COUNTY
ITEM NO: 7-20010.00 & 7-20013.00
PARTIAL DEPTH PCC PAVEMENT REPAIRS**

STATION	INSIDE SHOULDER	LANE #0	LANE #1	LANE #2	LANE #3	LANE #4	OUTSIDE SHOULDER	APPROX. SURF. AREA (SQ FT)	DEPTH (FT)	PARTIAL DEPTH PATCHING (CU FT)	SAW-CLEAN-RESEAL RANDOM CRACKS (LF)
30+44				X				2	0.28	0.56	
30+61				X				2	0.28	0.56	
30+79				X				2	0.28	0.56	
31+21				X				2	0.28	0.56	
31+32				X				4	0.28	1.12	
31+38				X				2	0.28	0.56	
31+51				X				1	0.28	0.28	
31+63				X				1	0.28	0.28	
32+11			X					2	0.28	0.56	
32+82				X				2	0.28	0.56	
33+00				X				3	0.28	0.84	
33+06			X					1	0.28	0.28	
33+17			X					1	0.28	0.28	
33+17				X				2	0.28	0.56	
33+30				X				2	0.28	0.56	
35+20			X					2	0.28	0.56	
35+80			X					1	0.28	0.28	
35+98			X					2	0.28	0.56	
35+98				X				1	0.28	0.28	
36+58			X					1	0.28	0.28	
36+58					X			1	0.28	0.28	
36+74				X				2	0.28	0.56	
36+74					X			2	0.28	0.56	
37+17			X					1	0.28	0.28	
37+34				X				1	0.28	0.28	
37+77			X					2	0.28	0.56	
37+77				X				1	0.28	0.28	
37+93			X					2	0.28	0.56	
37+93				X				1	0.28	0.28	
38+18			X					1	0.28	0.28	
38+42				X				1	0.28	0.28	
38+78				X				3	0.28	0.84	
39+38				X				1	0.28	0.28	
39+55			X					2	0.28	0.56	
39+55				X				1	0.28	0.28	

**I-75 & I-64 PAVEMENT REHABILITATION
FAYETTE COUNTY
ITEM NO: 7-20010.00 & 7-20013.00
PARTIAL DEPTH PCC PAVEMENT REPAIRS**

STATION	INSIDE SHOULDER	LANE #0	LANE #1	LANE #2	LANE #3	LANE #4	OUTSIDE SHOULDER	APPROX. SURF. AREA (SQ FT)	DEPTH (FT)	PARTIAL DEPTH PATCHING (CU FT)	SAW-CLEAN-RESEAL RANDOM CRACKS (LF)
39+65					X						7
39+73				X				1	0.28	0.28	
39+85			X					1	0.28	0.28	
39+86				X				1	0.28	0.28	
40+15				X				3	0.28	0.84	
40+32			X					2	0.28	0.56	
40+32				X				1	0.28	0.28	
40+45			X					2	0.28	0.56	
40+57				X				3	0.28	0.84	
40+74			X					2	0.28	0.56	
40+74				X				2	0.28	0.56	
40+91			X					1	0.28	0.28	
40+91				X				2	0.28	0.56	
41+04			X					2	0.28	0.56	
41+04				X				2	0.28	0.56	
41+16			X					1	0.28	0.28	
41+42				X							12
41+94			X					2	0.28	0.56	
42+83				X				2	0.28	0.56	
43+13			X					2	0.28	0.56	
43+13				X				2	0.28	0.56	
43+29				X				1	0.28	0.28	
43+30			X					1	0.28	0.28	
43+43			X					1	0.28	0.28	
43+43				X				1	0.28	0.28	
43+54				X				2	0.28	0.56	
43+68				X				1	0.28	0.28	
43+89				X				1	0.28	0.28	
44+02				X				1	0.28	0.28	
44+14			X					2	0.28	0.56	
44+14				X				2	0.28	0.56	
44+18				X				1	0.28	0.28	
44+32								1	0.28	0.28	
NORTHBOUND I-75 TO EASTBOUND I-64											
7+07			X					1	0.28	0.28	
7+36			X					3	0.28	0.84	
7+96			X					2	0.28	0.56	

**I-75 & I-64 PAVEMENT REHABILITATION
FAYETTE COUNTY
ITEM NO: 7-20010.00 & 7-20013.00
PARTIAL DEPTH PCC PAVEMENT REPAIRS**

STATION	INSIDE SHOULDER	LANE #0	LANE #1	LANE #2	LANE #3	LANE #4	OUTSIDE SHOULDER	APPROX. SURF. AREA (SQ FT)	DEPTH (FT)	PARTIAL DEPTH PATCHING (CU FT)	SAW-CLEAN-RESEAL RANDOM CRACKS (LF)
7+98			X					2	0.28	0.56	
8+99			X					4	0.28	1.12	
14+73			X					2	0.28	0.56	
15+45			X					1	0.28	0.28	
16+18			X					1	0.28	0.28	
16+95			X					1	0.28	0.28	
17+13			X					1	0.28	0.28	
17+59			X					2	0.28	0.56	
18+26			X					3	0.28	0.84	
18+45			X					1	0.28	0.28	
18+93			X					1	0.28	0.28	
19+53			X					1	0.28	0.28	
20+61			X					1	0.28	0.28	
20+72			X					6	0.28	1.68	
21+52											22
22+17			X					2	0.28	0.56	
22+52			X					1	0.28	0.28	
22+94			X					1	0.28	0.28	
23+24			X					1	0.28	0.28	
23+37			X					1	0.28	0.28	
23+72			X					1	0.28	0.28	
23+97			X					2	0.28	0.56	
24+13			X					1	0.28	0.28	
24+57			X					1	0.28	0.28	
25+17			X					1	0.28	0.28	
28+06			X					1	0.28	0.28	
28+94			X					3	0.28	0.84	
29+37			X					1	0.28	0.28	
29+72			X					2	0.28	0.56	
30+31			X					4	0.28	1.12	
30+44			X					2	0.28	0.56	
32+53			X					1	0.28	0.28	
33+32			X					1	0.28	0.28	
33+74			X					1	0.28	0.28	
33+92			X					2	0.28	0.56	
34+04			X					2	0.28	0.56	
34+41			X					2	0.28	0.56	

**I-75 & I-64 PAVEMENT REHABILITATION
FAYETTE COUNTY
ITEM NO: 7-20010.00 & 7-20013.00
PARTIAL DEPTH PCC PAVEMENT REPAIRS**

STATION	INSIDE SHOULDER	LANE #0	LANE #1	LANE #2	LANE #3	LANE #4	OUTSIDE SHOULDER	APPROX. SURF. AREA (SQ FT)	DEPTH (FT)	PARTIAL DEPTH PATCHING (CU FT)	SAW-CLEAN-RESEAL RANDOM CRACKS (LF)
34+72			X					1	0.28	0.28	
34+83			X					2	0.28	0.56	
34+89			X					1	0.28	0.28	
34+95			X					1	0.28	0.28	
35+11			X					2	0.28	0.56	
37+04			X					2	0.28	0.56	
37+72			X					2	0.28	0.56	
37+81			X					7	0.28	1.96	
38+06			X					4	0.28	1.12	
38+18			X					1	0.28	0.28	
38+36			X					1	0.28	0.28	
WESTBOUND I-64 TO SOUTHBOUND I-75											
1+85			X					2	0.28	0.56	
2+62			X					2	0.28	0.56	
3+23			X					4	0.28	1.12	
5+00			X					2	0.28	0.56	
5+88			X					2	0.28	0.56	
6+25			X					2	0.28	0.56	
6+49			X					4	0.28	1.12	
6+97			X					2	0.28	0.56	
7+09			X					2	0.28	0.56	
7+22			X					2	0.28	0.56	
7+57			X					2	0.28	0.56	
8+01			X					1	0.28	0.28	
14+75			X					1	0.28	0.28	
16+22			X					1	0.28	0.28	
16+37			X					1	0.28	0.28	
16+52			X					3	0.28	0.84	
17+66			X					1	0.28	0.28	
17+90			X					1	0.28	0.28	
17+99			X					1	0.28	0.28	
18+11			X					1	0.28	0.28	
18+29			X					1	0.28	0.28	
18+41			X					6	0.28	1.68	
18+78			X					3	0.28	0.84	
19+15			X					1	0.28	0.28	
21+26			X					2	0.28	0.56	
21+37			X					6	0.28	1.68	
22+09			X					2	0.28	0.56	
22+78			X					2	0.28	0.56	

**I-75 & I-64 PAVEMENT REHABILITATION
FAYETTE COUNTY
ITEM NO: 7-20010.00 & 7-20013.00
PARTIAL DEPTH PCC PAVEMENT REPAIRS**

STATION	INSIDE SHOULDER	LANE #0	LANE #1	LANE #2	LANE #3	LANE #4	OUTSIDE SHOULDER	APPROX. SURF. AREA (SQ FT)	DEPTH (FT)	PARTIAL DEPTH PATCHING (CU FT)	SAW-CLEAN-RESEAL RANDOM CRACKS (LF)
27+04 - 27+59			X								55
27+11			X								14
30+74			X					1	0.28	0.28	
31+45			X					1	0.28	0.28	
34+39			X					1	0.28	0.28	
34+69			X					1	0.28	0.28	
35+57			X					1	0.28	0.28	
36+28			X					1	0.28	0.28	
36+45			X					1	0.28	0.28	
37+05			X					1	0.28	0.28	
37+65			X					3	0.28	0.84	
38+55			X					6	0.28	1.68	
39+96			X					1	0.28	0.28	
43+22			X					2	0.28	0.56	
43+34			X					3	0.28	0.84	
43+81			X					1	0.28	0.28	
44+53			X					1	0.28	0.28	
46+80			X					2	0.28	0.56	
47+40			X					1	0.28	0.28	
PROJECT TOTAL - SAW-CLEAN-RESEAL RANDOM CRACKS (LF)											158
PROJECT TOTAL - PARTIAL DEPTH PATCHING - POLYMER MOD (CU FT)											178
<p><i>Lane numbers begin with the left most driving lane slabs (lane #1, or lane #0 where there is an auxilliary lane on the inside) and increase as you move right into the right most slabs. Note that shoulders were noted directly. (Each Direction Separately)</i></p> <p><i>Approximate partial depth pavement repair locations are listed in this proposal. The Engineer will determine the exact location at the time of construction.</i></p> <p><i>Note: Quantities are carried over to the General Summary</i></p>											

**I-75 & I-64 PAVEMENT REHABILITATION
FAYETTE COUNTY
ITEM NO. 7-20010.00 & 7-20013.00
ASPHALT PAVEMENT REPAIRS**

BEGIN M.P.	END M.P.	DIRECTION	INSIDE SHOULDER	LANE #1	LANE #2	LANE #3	OUTSIDE SHOULDER	APPROX. SURF. AREA (SQ FT)	PAVEMENT REPAIR (SQ YD)
NB I-75									
110.23	110.23					X		109	12
110.26	110.27			X	X	X		396	44
111.70	111.70					X		228	25
SB I-75									
109.73	109.74			X	X	X		288	32
111.52	111.53				X	X		1714	190
111.62	111.63			X				920	102
U.S. 60 RAMP D									
STATION	STATION								
7+79	7+98				X			228	25
MAN O' WAR RAMP B									
STATION	STATION								
17+22	17+62						X	400	44
21+02	21+29			X				405	45
WB I-64 TO SB I-75									
STATION	STATION								
13+62	13+70		X					48	5
14+22	14+30						X	96	11
15+81	15+89						X	96	11
20+88	20+96						X	99	11
I-75 TOTALS									519
I-64 TOTALS									38
PROJECT TOTALS									557

Lane numbers begin with the left most driving lane (lane #1 and increase as you move right into the right most lane. Note that shoulders were noted directly. (Each Direction Separately)

Approximate pavement repair locations are listed in this proposal. The Engineer will determine the exact location and type of repair at the time of construction.

Note: Quantities are carried over to the Paving Summary and the General Summary

I-75 FAYETTE COUNTY PAVEMENT REHABILITATION, MILE POST 107.453 TO 111.95 ITEM NO. 7-20013 DRAINAGE SUMMARY																			
LOCATION	BEGIN MILE POST (I-75)	END MILE POST (I-75)	END STATION (I-64)	TYPE	CLEAN INLET/OUTLET (1)	CULVERT PIPE 15 INCH	NON-PERFORATED PIPE 4 INCH	PERF. PIPE HEADWALL TYPE 3 - 4 INCH	PIPE CULVERT HEADWALL - 15 INCH	CURB BOX INLET TYPE B-1	FLUME INLET TYPE 2	FLOWABLE FILL	REMOVE AND RESET GUARDRAIL	CHANNEL LINING CLASS II (2)	CHANNEL LINING CLASS III (2)	SEEDING AND PROTECTION	CONCRETE WEDGE CURB	REPLACE GRATE	COMMENTS
					---	LF	LF	EACH	EACH	EACH	EACH	CU YD	LF	TON	TON	SQ YD	LF	EACH	
LT	107.22	107.22			1									2					PIPE HEADWALL
LT	107.30	107.30												5					PIPE HEADWALL
LT	107.70	107.70				4		1						5					PIPE HEADWALL
LT	107.84	107.84			1														PIPE HEADWALL
RT	107.96	107.63									6		1712		60	150	1712		ADD CURB AND FLUMES AT GUARDRAIL
LT	107.98	107.98			1														PIPE HEADWALL
LT	108.23	108.23			1														PIPE HEADWALL
LT	108.74	108.74			1									2					PIPE HEADWALL
LT	109.01	109.01			1														PIPE HEADWALL
LT	109.19	109.19			1									5					PIPE HEADWALL
LT	109.41	109.41			1									5					PIPE HEADWALL
LT	110.07	110.07			1									3					PIPE HEADWALL
LT	110.18	110.18			1													1	PIPE HEADWALL
LT	110.25	110.25			1							3				50			PIPE HEADWALL
MEDIAN	110.51	110.51			1														STABILIZE DITCH AND INLET
LT	110.92	110.92			1														PIPE HEADWALL
RT	110.93	110.93					10	1		1									REPLACE DAMAGED TOP PHASE
LT	111.19	111.19																	PIPE HEADWALL
LT	111.20	111.20			1														PIPE HEADWALL
LT	111.89	111.89			1														PIPE HEADWALL
LT	111.94	111.94			1														PIPE HEADWALL
NORTHBOUND I-75																			
RT	108.19	108.19			1														PIPE HEADWALL
RT	108.43	108.43			1														PIPE HEADWALL
RT	108.47	108.47			1									20					PIPE HEADWALL
RT	108.51	108.51			1									5					PIPE HEADWALL
RT	108.53	108.53			1									5				1	PIPE HEADWALL
RT	108.68	108.68												5					PIPE HEADWALL
RT	108.73	108.73												5				1	PIPE HEADWALL
RT	108.77	108.77			1														PIPE HEADWALL
RT	109.22	109.22			1														PIPE HEADWALL
RT	109.64	109.64			1													1	PIPE HEADWALL
RT	110.28	110.28												10					PIPE HEADWALL
RT	110.34	110.34												10					PIPE HEADWALL
LT	110.82	110.82			1														PIPE HEADWALL
RT	111.36	111.36			1														DBI
RT	111.83	111.83			1														PIPE HEADWALL
RT	111.87	111.87			1													1	PIPE HEADWALL

I-75 FAYETTE COUNTY PAVEMENT REHABILITATION, MILE POST 107.453 TO 111.95 ITEM NO. 7-20013 DRAINAGE SUMMARY																			
LOCATION	BEGIN MILE POST (I-75)	END MILE POST (I-75)	END STATION (I-64)	TYPE	CLEAN INLET/OUTLET (1)	CULVERT PIPE 15 INCH	NON-PERFORATED PIPE 4 INCH	PERF. PIPE HEADWALL TYPE 3 - 4 INCH	PIPE CULVERT HEADWALL - 15 INCH	CURB BOX INLET TYPE B-1	FLUME INLET TYPE 2	FLOWABLE FILL	REMOVE AND RESET GUARDRAIL	CHANNEL LINING CLASS II (2)	CHANNEL LINING CLASS III (2)	SEEDING AND PROTECTION	CONCRETE WEDGE CURB	REPLACE GRATE	COMMENTS
LT	108.32	108.32			1										3				PIPE HEADWALL
I-75 / MAN O WAR RAMP-A1																			
LT	108.09	108.09			1														PIPE HEADWALL
RT	108.09	108.09			1														DBI
RT	108.17	108.17			1														PIPE HEADWALL
RT	108.17	108.17			1													1	PIPE HEADWALL
I-75 / MAN O WAR RAMP-E																			
MED	108.18	108.18												5					DBI
I-75 / US-60 RAMP-A																			
LT	109.83	109.83			1														PIPE HEADWALL
I-75 / US-60 RAMP-C																			
RT	109.64	109.64			1													1	PIPE HEADWALL
RT	109.64	109.64			1														PIPE HEADWALL
LT	109.63	109.63			1									5					PIPE HEADWALL
I-75 / US-60 RAMP-DD																			
LT	109.82	109.82			1														PIPE HEADWALL
NORTHBOUND I-75 TO EASTBOUND I-64 RAMP																			
RT	7+17	7+17			1														PIPE HEADWALL
RT	13+06	13+06			1														PIPE HEADWALL
WESTBOUND I-64 TO NORTHBOUND I-75 RAMP																			
RT	38+68	38+68			1									10				1	PIPE HEADWALL
LT	39+70	39+70			1														PIPE HEADWALL
RT	47+49	47+49			1											100	200		PIPE HEADWALL
RT	27+65	25+65								1									PIPE HEADWALL
RT	27+75	27+75													3				PIPE HEADWALL
SOUTHBOUND I-75 TO EASTBOUND I-64 RAMP																			
RT	8+94	8+94			1														CURB DRAIN
RT	15+09	15+09			1														PIPE HEADWALL
RT	25+47	25+47			1														DBI
I-64 TOTALS					8	0	0	0	0	0	1	0	200	10	3	100	200	1	
I-75 TOTALS					34	4	10	1	1	1	6	3	1,762	115	75	200	1,737	7	
PROJECT TOTALS (3)					42	4	10	1	1	1	7	3	1,962	125	78	300	1,937	8	

(1) - CLEAN INLET/OUTLET IS INCIDENTAL TO DITCHING
 (2) - ANY EXCAVATION AND FABRIC-GEOTEXTILE CLASS 2 REQUIRED TO PLACE THE CHANNEL LINING IS INCIDENTAL TO THE LINING.
 (3) - ALL QUANTITIES ARE CARRIED OVER AND INCLUDED IN THE GENERAL SUMMARY.

**I-64 AND I-75 FAYETTE COUNTY
I-75 MILEPOST 107.453 - 111.95
I-64 MILEPOST 81.037 – 82.19
Item No. 7-20010.00 (I-64)
Item No. 7-20013.00 (I-75)
FD52 034 0075 107-112
FD52 034 0064 081-083
NHPP 0645 (081)**

**THIS PROJECT IS A FULLY
CONTROLLED ACCESS HIGHWAY**

I. DESCRIPTION

Perform all work in accordance with the *Kentucky Transportation Cabinet, Department of Highways, Standard Specifications for Road and Bridge Construction, Edition of 2019*, Supplemental Specifications, any applicable Special Provisions, and applicable Standard and Sepia Drawings, except as hereafter specified. Article references are to the Standard Specifications. Furnish all materials, labor, equipment, and incidentals for the following work:

(1) Maintain and Control Traffic; (2) Remove and reset or replace Guardrail and Guardrail End treatments at the locations listed and/or as directed by the Engineer; (3) Inlaid Pavement Markers on asphalt pavement; (4) Type V pavement markers on concrete pavement; (5) Asphalt Pavement Milling and Texturing; (6) Asphalt Surface and Asphalt Base at locations listed and/or as directed by the Engineer; (7) Remove and replace JPC Pavement at the locations listed and/or as directed by the Engineer; (8) Permanent Striping; (9) Re-saw and seal joint seals; (10) PCC pavement diamond grinding; and (11) All other work specified as part of this contract.

II. MATERIALS

Except as specified in these notes or on the drawings, all materials will be according to the Standard Specifications and applicable Special Provisions and Special Notes. The Department will sample and test all materials according to Department's Sampling Manual and the Contractor will have the materials available for sampling a sufficient time in advance of the use of the materials to allow for the necessary time for testing, unless otherwise specified in these notes.

- A. **Maintain and Control Traffic.** See Traffic Control Plan.
- B. **Dense Graded Aggregate.** Crushed Stone Base may not be furnished in lieu of DGA.
- C. **Jointed Plain Concrete Pavement 11".** Use Jointed Plain Concrete Pavement 11" for full depth replacement of concrete pavement in mainline driving lanes. Either central mixing or truck mixing will be allowed.
- D. **Pavement Markings - 6 inch Thermoplastic.** Use 6-inch Thermoplastic markings for permanent striping on asphalt.

- E. **Pavement Markings - 12 inch Thermoplastic.** Use 12-inch Thermoplastic markings for permanent striping on ramp gores.
- F. **Pavement Markings - 6 inch Durable Type-1.** Use 6-inch Durable Type I markings for permanent striping on bridge Decks and PCC pavement.
- G. **Crushed Aggregate Size No. 2.** Crushed Aggregate Size No. 2 will be limestone.
- H. **Channel Lining Class II and Class III.** Channel lining will be limestone and is to be placed in eroded areas as directed by the Engineer. Fabric-Geotextile Class 2 will not be measured for payment, but will be considered incidental to the channel lining.

III. CONSTRUCTION METHODS

- A. **Maintain and Control Traffic.** See Traffic Control Plan.
- B. **Site Preparation.** Be responsible for all site preparation. Do not disturb existing signs. This item will include, but is not limited to, incidental excavation and backfilling; removal of all obstructions or any other items; disposal of materials; sweeping and removal of debris; shoulder preparation and restoration, temporary and permanent erosion, and pollution control; and all incidentals. Site preparation will be only as approved or directed by the Engineer. Other than the bid items listed, no direct payment will be made for site preparation, but will be incidental to the other items of work.
- C. **Channel Lining.** Place channel lining as directed by the Engineer
- D. **Concrete Pavement Removal and Replacement.** Except as specified in these notes, perform full depth concrete pavement removal and replacement in accordance with the Special Note for Full Depth Concrete Pavement Repair. Approximate removal locations are listed in the proposal. The Engineer will determine actual locations at the time of construction and may add to the listed repairs if deemed necessary. Remove pavement for full depth repairs by a saw cut and lift method without disturbing the underlying base or damaging the adjacent pavement remaining in place. Do not "pre-saw" in advance until ready for slab removal within more than 24 to 48 hours of removal. (The Engineer will not allow the slab to be sawed and then to remain under traffic for more than 48 hours after sawing.) Pre-saw only in locations directed by the Engineer. Do not hammer or break pavement by other means to facilitate removal. Do not oversaw into existing JPC Pavement not intended to be removed. The original nominal depth of the mainline JPC pavement is 11 inches. However, the finished grade will be transitioned to match the adjacent pavement to remain in place. Rideability requirements will be based on the 10' straightedge method. See section 501.03.13 in the specifications for concrete finishing. Gang drills, capable of drilling a minimum of four holes at a time, are required for dowel, hook bolt, and tie bar placement, unless otherwise approved by the Engineer.

It is intended to not disturb the underlying soil; however, a quantity of DGA, Excavation, Crushed Aggregate #2, Geotextile-Fabric class 1A, 4" Perforated pipe and 4" Non- perforated pipe (to drain the aggregate) and Perforated Pipe Headwalls is included for undercutting very poor, soft, wet soils - to be used sparingly and only as directed by the Engineer. Undercutting will be measured as Roadway Excavation.

Use of a maturity meter is permitted to verify that JPC is ready for traffic but is considered incidental to 11" JPC Pavement.

- E. **Partial Depth Patching.** Except as specified in these notes, perform Partial Depth Patching in accordance with Special Note for Partial Depth Concrete Pavement Repair. The Engineer will determine the removal locations. It is intended that the Polymer Patching material be used to fill these corner breaks without grinding and preparing the hole. The Engineer will determine actual locations at the time of construction. This material may be Diamond Ground.
- F. **Disposal of Waste.** Dispose of all cuttings, debris, and other waste off the right-of-way at approved sites obtained by the Contractor at no additional cost to the Department. The contractor will be responsible for obtaining any necessary permits for this work. Temporary openings in the right of way fence for direct access to waste sites off the right of way or for access to other public roads will not be allowed. No separate payment will be made for the disposal of waste and debris from the project or obtaining the necessary permits but will be incidental to the other items of the work.
- G. **Final Dressing, Clean Up, and Seeding and Protection.** After all work is completed, completely remove all debris from the job site. Perform Class A Final Dressing on all disturbed areas. Sow disturbed earthen areas with Seed Mixture No. 1. These items are incidental to other items in the contract.
- H. **Guardrail.** Remove and replace guardrail and guardrail End Treatments listed in this proposal and/or as directed by the Engineer. Guardrail, End Treatments and Terminal Sections are listed by mile points and quantities are approximate only. Actual locations will be determined by the Engineer at the time of construction. Grade and reshape shoulders to proper template for new End Treatment. Utilize DGA for embankment when required for new end treatments. Remove any existing guardrail with a lane closure in place.

Do not leave the area unprotected. After the guardrail is removed, a shoulder closure shall remain in place until the guardrail is replaced in that area. To minimize safety hazards, guardrail removal is to be performed at the latest practical time prior to initiating the paving operation in an area and re-installation is to begin within 5 calendar days from the time that the final base course is completed and shall be pursued until completion. If guardrail installation is not started within 5 calendar days after paving operations ends, Liquated Damages will be charged as outlined in Section 108 of the 2019 Standard Specifications.

The Contractor shall deliver existing salvaged guardrail system materials to the Central Sign Shop and Recycle Center in in Frankfort, KY (502-564-8187) between the hours of 8:00AM and 3:00PM, Monday through Friday and shall be neatly stacked in accordance with section 719.03.07 of the standard specifications. There is a guardrail delivery verification sheet which must be completed. The Contractor, Engineer, and Central Sign/Guardrail Center representative must all sign off on this sheet before payment may be made.

- I. **Pavement Striping and Pavement Markers.** Permanent striping will be in accordance with Section 112 and Section 714, except that:
- (1). Striping will be 6" in width on the driving lanes and 12" in width on the ramp gores.
 - (2). Permanent striping configuration will be in place before a lane is opened to traffic; and
 - (3). Permanent striping will be 6" Thermoplastic markings on asphalt, 12" Thermoplastic markings on asphalt ramp gores, and 6" Durable Type 1 Markings on Bridge Decks and concrete pavement and 12" Durable Type 1 Markings on concrete ramp gores.
- J. **On-Site Inspection.** Each Contractor submitting a bid for this work will make a thorough inspection of the site prior to submitting a bid and will thoroughly familiarize himself with existing conditions so that the work can be expeditiously performed after a contract is awarded. Submission of a bid will be considered evidence of this inspection having been made. Any claims resulting from site conditions will not be honored by the Department.
- K. **Caution:** Information shown on the drawings and in this proposal and the types and quantities of work listed are not to be taken as an accurate or complete evaluation of the material and conditions to be encountered during construction. The bidder must draw his own conclusions as to the conditions encountered. The Department does not give any guarantee as to the accuracy of the data and no claim will be considered for additional compensation if the conditions encountered are not in accordance with the information above.
- L. **Utility Clearance.** It is not anticipated that utility facilities will need to be relocated and/or adjusted; however, if it is discovered that the work does require that utilities be relocated and/or adjusted, the utility companies will work concurrently with the Contractor while relocating their facilities.

IV. METHOD OF MEASUREMENT

- A. **Maintain and Control Traffic.** See Traffic Control Plan.
- B. **Site Preparation.** Other than the bid items listed, site preparation will not be measured for payment, but will be incidental to the other items of work.
- C. **Crushed Aggregate Size No. 2.** Crushed Aggregate will be used in the event it is necessary to stabilize under any of the full depth slab removal. Payment will be based on the tons used for stabilization and the tons used around the perforated pipe outlet headwalls.
- D. **Dense Graded Aggregate.** DGA used for guardrail end treatments will be measured for payment. DGA will be used in the event it is necessary to stabilize under any of the full depth slab removal. A 4-inch lift will be placed on the Crushed Aggregate No. 2s.
- E. **Remove JPC Pavement.** Cement concrete pavement removed in full depth pavement repair areas will be measured in square yards, regardless of thickness. See Special Note for Full Depth Concrete Pavement Repair.

- F. **JPC Pavement-11"**. See Special Note for Full Depth Concrete Pavement Repair. No additional payment will be made for any additional concrete required due to a depth beyond 11". If any rumble strips are required on any of the shoulders, they shall be considered incidental to this work.
- G. **Epoxy Resin Systems**. Epoxy Resin Systems will not be measured for payment but will be incidental to JPC Pavement 11".
- H. **Partial Depth Patching**. Partial Depth Patching is measured by the cubic foot according to Special Note for Partial Depth Concrete Pavement Repair.
- I. **Smooth Dowels, Deformed Tie Bars and Hook Bolts**. Smooth dowels, deformed tie bars, hook bolts, and joint sealing at JPC pavement repair areas will not be measured for payment but will be incidental to JPC Pavement 11".
- J. **Fabric-Geotextile Class 1A**. Fabric-Geotextile Class 1A will be measured per square yard and is to be used to wrap crushed aggregate No. 2 for stabilization after slab removal.
- K. **Undercutting**. Undercutting existing PCC pavement will be measured by cubic yards of excavation.
- L. **Permanent Striping**. Permanent striping Thermo marking and Durable Type 1 marking (6" and 12") is measured per linear foot. See Traffic Control Plan.
- M. **Inlaid Pavement Markers** Inlaid Pavement Markers are measured as each.
- N. **Raised Pavement Markers** Type V Pavement Markers are measured as each.

V. BASIS OF PAYMENT

No direct payment will be made other than for the bid items listed. All other items required to complete the construction will be incidental to the bid items listed. Existing signs damaged by the Contractor will be replaced by the Contractor at his expense.

- A. **Maintain and Control Traffic**. See Traffic Control Plan.
- B. **Site Preparation**. Other than the bid items listed, no direct payment will be allowed for site preparation, but will be incidental to the other items of work.
- C. **Remove JPC Pavement**. See Modified Special Note for Full Depth Concrete Pavement Repair.
- D. **JPC Pavement -11"** See Modified Special Note for Full Depth Concrete Pavement Repair. No additional payment will be made for any additional concrete required due to a depth beyond 11".
- E. **Dense Grade Aggregate**. See Section 302 of the Standard Specifications.
- F. **Inlaid Pavement Markers, Raised Pavement Markers and Permanent Striping**. See Special Notes and Traffic Control Plan.

**NOTES APPLICABLE TO PROJECT
PAVEMENT REHABILITATION
DIAMOND GRINDING REHABILITATION
ASPHALT MILLING AND TEXTURING**

I-64 AND I-75 FAYETTE COUNTY

I-75 MILEPOST 107.453 - 111.95

I-64 MILEPOST 81.037 – 82.19

Item No. 7-20010.00 (I-64)

Item No. 7-20013.00 (I-75)

FD52 034 0075 107-112

FD52 034 0064 081-083

NHPP 0645 (081)

-
1. The dimensions shown on the typical section for pavement and shoulder widths and thickness are nominal or typical dimensions. The actual dimensions to be constructed may be varied to fit existing conditions as directed or approved by the Engineer. It is not intended that existing pavement or shoulders be widened unless specified in the Proposal.
 2. There is a summary of full depth concrete repair locations. Because of continuing deterioration of the pavement, there is an additional quantity of repairs included in the bid total. The Engineer will determine the ultimate locations that will be repaired based upon the condition of the pavement at the time the repairs are accomplished. The repair locations listed may be lengthened, shortened, or eliminated completely if the conditions are such that modification of the locations would be deemed desirable by the Department. Any asphalt pavement sections, or patches removed, in the driving lanes, and their disposal will be incidental to the underlying "Remove PCC Pavement" bid item.
 3. The contractor is to be advised locations of low wires may exist. The following locations are approximate:

I-75 MP 108.23 – Sta. 484+96	WB I-64 to NB I-75 Sta. 34+70
I-75 MP 109.69 - Sta. 561+93	WB I-64 to NB I-75 Sta. 48+03
I-75 MP 109.73 – Sta. 564+62	WB I-64 TO SB I-75 Sta. 16+95
I-75 MP 109.89 – Sta. 572+84	WB I-64 TO SB I-75 Sta. 31+20
I-75 MP 111.15 – Sta. 381+80	SB I-75 to EB I-64 Sta. 5+35
I-75 MP 112.00 – Sta. 336+25	SB I-75 to EB I-64 Sta. 27+90
	NB I-75 TO EB I-64 Sta. 31+56

The contractor is to be advised locations of high-pressure gas mains may exist. The following locations are approximate:

MP 109.34 – Sta. 543+92 (I-75) 12” HPGM

The contractor is to be advised locations of encasement pipe may exist. The following locations are approximate:

MP 111.37 – Sta. 370+38 (I-75 NB), Sta. 369+94 (I-75 SB) 18” encasement pipe

CAUTION: Other Locations may exist. These and all other utilities should be avoided on this project. If any utility is impacted, it will be the contractor’s responsibility to contact the affected utility and cover any costs associated with the impact.

4. Guardrail, End Treatments, and Terminal Sections to be replaced are listed by mileposts. Exact placement to be approved by the Engineer on construction.

Install guardrail and associated items at MP 110.83 to MP 110.86 – Sta. 396+14.85 (I-75 SB) to Sta. 397+89.85 (I-75 SB)

Item 02351 GUARDRAIL-STEEL 'W' BEAM-S FACE	LF – 175
Item 02369 GUARDRAIL END TREATMENT TYPE 2A	EA – 1
Item 02387 GUARDRAIL CONNECTOR TO BRIDGE END TY A-1	EA – 1
Item 22883EN CONCRETE WEDGE CURB	LF – 25

(These items have been carried to the general summary)

5. All “green” milepost signs shall be replaced with this project. Payment for these signs will be made by “each” for the bid item “Steel Post Mile Markers”. Any damaged will be replaced at the contractor’s expense.
6. All blue milepost signs on the project are not to be disturbed. The contractor will be responsible for the replacement of these signs if damaged during construction.
7. Any roadway signs that are damaged during construction are to be replaced at the contractor's expense. Overhead truss sign structures are present within the project limits. The following locations are approximate:
 - MP 109.43 – Sta. 548+37 (I-75)
 - MP 109.74 – Sta. 564+97 (I-75)
 - MP 109.95 – Sta. 575+96 (I-75)
 - MP 110.10 – Sta. 583+95 (I-75)
 - MP 110.25 – Sta. 591+08 (I-75)
 - MP 110.34 – Sta. 424+80 (I-75 NB)
 - MP 111.19 – Sta. 379+59 (I-75 SB)
8. Any light poles that are damaged during construction are to be replaced at the contractor's expense.
9. The existing edge drain system is to be preserved. Care should be taken when the deteriorated concrete is removed and replaced. Additionally, there is a small quantity of perforated pipe, non-perforated pipe, and pipe headwalls set-up to be used at the engineer's discretion. Payment will be based on the actual quantities measured in the field by the Engineer.
10. DGA, flowable fill, crushed aggregate No. 2 and geotextile fabric used to back fill the proposed perforated and non-perforated pipe trench will be incidental to the price of the 4" perforated and 4" non-perforated pipe and no additional payment will be permitted.
11. Non-perforated pipe will be backfilled with flowable fill. Backfill of the non-perforated pipe with flowable fill will be incidental to the bid item "Non-perforated Pipe — 4 Inch".
12. All pipe connections in the edge drain system will be rigid.
13. Edge drains damaged during placement of additional outlets will be replaced at the contractor's expense.

14. Ditching is included with this project. The contractor shall remove all debris from ditches, including boulders and brush. The contractor shall remove all loose rock and brush up to and including the first bench cut in the existing rock cuts or as directed by the engineer. Ditching is paid per length of the project and will include all ditches.
15. Delineators shall meet the requirements of Section 830 and 838 of the Standard Specifications. Delineators shall be placed in accordance with Section 3F of the M.U.T.C.D.
16. Pavement rideability requirements in accordance with section 410 category A of the standard specifications shall apply on this project.
17. The Department will accept the compaction of asphalt mixtures furnished for the driving lanes at one inch or greater on this project by Option A according to subsections 402 and 403 of the Standard Specifications, Current Edition. The Department will accept the compaction of all other mixtures by option B.
18. The Contractor shall be responsible for the repair of any asphalt or concrete in the travelled lanes that becomes detrimental or hazardous to the travelling public during construction. Areas needing repair will be at the discretion of the Engineer.
19. Existing pavement markers in the mainline concrete will be removed. A partial depth patch to repair the pavement at the removal locations shall be considered incidental to "Remove Pavement Marker TY V".
20. A quantity of "Leveling and Wedging PG76-22" has been included to patch any potholes in the asphalt shoulders throughout the project as directed by the Engineer.
21. E-ticketing will be required on this project but will not be measured for payment. See Construction Memorandum No. 01-2020 for contactless electronic ticketing.
22. This project is considered a Significant Project.

TRAFFIC CONTROL PLAN
I-64 FAYETTE COUNTY
ITEM NO. 7-20010.00
I-75 FAYETTE COUNTY
ITEM NO. 7-20013.00

**THIS PROJECT IS A FULLY
CONTROLLED ACCESS HIGHWAY**

TRAFFIC CONTROL GENERAL

Except as provided herein, maintain and control traffic in accordance with the 2019 Standard Specifications and the Standard Drawings, current editions. Except for the roadway and traffic control bid items listed, all items of work necessary to maintain and control traffic will be paid at the lump sum bid price to "Maintain and Control Traffic". All lane closures used on the Project will follow the appropriate Standard Drawings. Do NOT use Cones for lane closures or shoulder closures.

Contrary to Section 106.01, traffic control devices used on this project may be new or used in like new condition at the beginning of the work and maintained in like new condition until completion of the work. Traffic Control Devices will conform to current MUTCD.

Reduce the speed limit in work areas to 55 miles per hour and establish double fines for work zone speeding violations. The extent of these areas within the project limits will be restricted to the proximity of actual work areas as determined by the Engineer. Notify the Engineer a minimum of 12 hours prior to using the double fine signs. At the beginning of the work zone, the "WARNING FINE DOUBLED IN WORK ZONE" signs will be dual mounted. At the end of the work zone, the "END DOUBLE FINE" signs will be dual mounted as well. Remove or cover the signs when the highway work zone does not have workers present for more than a two-hour period. All signs shall be placed as directed and/or approved by the Engineer. Payment for the signs will be at the unit bid price for signs erected. Any relocation or covering of the signs will be incidental to Maintain and Control Traffic.

Night work is required on this project. Obtain approval from the Engineer for the method of lighting prior to its use.

PROJECT PHASING & CONSTRUCTION PROCEDURES

The contractor **shall maintain a minimum of one lane** in each direction for I-75 and I-64 during the days and hours stated in this proposal. All lanes must be striped and open at all other times and hours unless otherwise stated in this proposal or approved by the Engineer. No lane closures will be permitted the following days for both I-75 and I-64:

May 28-30, 2022

July 2-5, 2022

September 2-5, 2022

Memorial Day Weekend

Independence Day

Labor Day Weekend

Traffic may be reduced to one lane on I-75 from 7:00 p.m. to 5:30 a.m. daily and traffic may be reduced to one lane on I-64 from Fridays at 7:00 p.m. to 5:30 a.m. Mondays.

The Westbound I-64 to Southbound I-75 ramp and the Northbound I-75 to Eastbound I-64 ramp may be closed for only one weekend each from 7:00 p.m. on Friday to 5:30 a.m. on Monday. Only one ramp closure will be permitted at a time.

All Concrete work on I-64 mainline and ramps is to be completed prior to August 15, 2022.

Use only one lane closure in each direction of travel at the same time during the hours specified. The clear lane width will be 11 feet; however, make provisions for the passage of wide loads up to 16 feet in width. Use a lane closure all times when work is performed in the lane or adjacent shoulder. Shoulders used as temporary roadways will be inspected by the Engineer and if deemed necessary by the Engineer, repaired with Asphalt Mixture for Level & Wedging as directed prior to opening to traffic. Perform any maintenance of the shoulder as deemed necessary by the Engineer to maintain traffic. Remove existing striping by water blasting.

All pavement edge transitions must be smooth and level before opening lanes up to traffic. A lane closure must be in place during all times that pavement edge drop-offs are present (see Pavement Edge Drop-off note).

Approximate full depth pavement repair locations are listed in the proposal. The Engineer will determine exact locations of pavement repairs, at the time of construction. Once removal of pavement at a particular repair location has begun, work continuously within the parameters outlined above to complete the work and eliminate the "hole". Place Type III Barricades immediately in front of pavement removal areas, if not protected from traffic behind temporary concrete barrier wall, until the new JPC Pavement achieves 3000PSI compressive strength. Payment for Type III Barricades will be considered incidental to the bid item "Maintain and Control Traffic".

Once pavement removal at a site has begun, pavement replacement must be completed within the time a lane closure is allowed.

Access to all ramps at all interchanges on the project shall be maintained always unless otherwise stated in this proposal or directed by the Engineer.

Note that lane shifts are required throughout the project. Stripe according to the MUTCD.

During the days and hours when a lane closure is allowed, implement the following procedures: Maintain traffic as specified in the phasing notes. Maintain at least 6 feet of lateral clearance between the traveled lanes and any drop off resulting from pavement removal if not protected with temporary barrier wall. Any other work not requiring traffic lane widths to be restricted due to barrels or equipment encroaching into the interior lanes can be done during the remaining hours when all lanes of traffic must be maintained. Please refer to the “Special Note for Fixed Completion Date and Liquidated Damages” for damage rates per hour associated with failure to maintain the required number of lanes during the specified time. Once pavement milling at a site has begun, pavement must be completed within the time a lane closure is allowed. Liquidated Damages, at the rate specified per hour in the “Special Note for Fixed Completion Date and Liquidated Damages”, will be assessed for each hour the existing number of lanes is not maintained.

The contractor must notify the Engineer at least fourteen (14) days prior to beginning construction in either direction.

CONSTRUCTION PHASING

The Contractor will develop their own maintenance of traffic plan (MOT), including signed detour plans that conforms to these notes and the dates and times listed above. The MOT plans shall be submitted by a traffic control supervisor and approved by the Engineer prior to implementation. All closures must be approved by the Engineer at least 14 days prior to the closure. Lane closures will NOT be measured for payment, but are considered incidental to “Maintain and Control Traffic” lump sum.

SHOULDER PREPARATION AND RESTORATION

Prior to placing any lane closures that require shifting traffic onto existing shoulders, patch and remove any foreign debris on the shoulders as directed by the Engineer. Removal of failed materials and additional patching shall be performed by the Contractor as directed by the Engineer during the time the shoulder is used as a travel lane. DGA and Leveling and Wedging PG76-22 will be paid at the Contract unit bid prices; all other shoulder preparation, maintenance, and restoration shall be incidental to other items of work.

LANE CLOSURES

Limit the lengths of lane closures to only that needed for actual operations in accordance with the phasing specified herein, or as directed by the Engineer. Contrary to section 112, lane closures will NOT be measured for payment, but are considered incidental to Maintain and Control Traffic.

SIGNS

Additional traffic control signs in addition to normal lane closure signing detailed on the Standard Drawings may be required by the Engineer. Additional signs needed for lane closures may include, but are not limited to, dual mounted TRUCKS USE LEFT/RIGHT LANE, LEFT/RIGHT LANE CLOSED 1 MILE, LEFT/RIGHT LANE CLOSED 2 MILES, LEFT/RIGHT LANE CLOSED 3 MILES, SLOWED/STOPPED TRAFFIC AHEAD. Signage for reduced speed limits and double fine work zones will be furnished, relocated, and maintained by the Contractor.

Contrary to section 112, Individual signs will be measured only once for payment, regardless of how many times they are set, reset, removed, and relocated during the duration of the project. Replacements for damaged signs or signs directed to be replaced by the Engineer due to poor legibility or reflectivity will not be measured for payment.

A quantity of signs has been included for detours, lane shifts, "Roadwork Ahead" signs on entrance ramps, and extra Double Fine signs and Speed Limit signs between interchanges to be paid only once no matter how many times they are moved or relocated.

FLASHING ARROWS

Provide flashing arrow panels in advance of or on the project at locations to be determined by the Engineer. The arrow panels shall be in operation at all times. In the event of damage or mechanical failure, immediately repair or replace the arrow panels. The Department will measure for payment the maximum number of arrow panels in concurrent use at the same time on a single day on all sections of the contract. Individual arrow panels will be measured only once for payment, regardless of how many times they are set, reset, removed, and relocated during the duration of the project. Replacements for damaged arrow panels directed by the Engineer to be replaced due to poor condition will not be measured for payment. Arrow panels will remain the property of the Contractor after construction is complete.

PORTABLE CHANGEABLE MESSAGE SIGNS

Provide portable changeable message signs (PCMS) in advance of or on the project at locations to be determined by the Engineer. The Engineer will designate the locations and messages to be provided. Unless directed otherwise by the Engineer, use messages and abbreviations according to the Policy for the Use and Placement of Changeable Message Signs. The PCMS shall be in operation at all times. In the event of damage or mechanical failure, immediately repair or replace the PCMS. The Department will measure for payment the maximum number of signs in concurrent use at the same time on a single day on all sections of the contract. Individual signs will be measured only once for payment, regardless of how many times they are set, reset, removed, and relocated during the duration of the project. Replacements for damaged signs directed by the Engineer to be replaced due to poor condition or readability will not be measured for payment. PCMS will remain the property of the Contractor after construction is complete.

TRUCK MOUNTED ATTENUATORS

Furnish and install MUTCD approved truck mounted attenuators (TMA) in advance of work areas when workers are present less than 12 feet from traffic. If there is less than 500 feet between work sites, only a single TMA will be required at a location directed by the Engineer. Locate the TMAs at the individual work sites and move them as the work zone moves within the project limits. All details of the TMA installations shall be approved by the Engineer. TMA will not be measured for payment, but are incidental to "Maintain and Control Traffic," lump sum. The Department **WILL NOT** take possession of the TMAs upon completion of the work.

PAVEMENT MARKINGS

If lane closures are in place during nighttime hours, remove or cover the lenses of raised pavement markers that do not conform to the traffic control scheme in use, or as directed by the Engineer. Replace or uncover lenses before a closed lane is reopened to traffic. No direct payment will be made for removing and replacing or covering and uncovering the lenses but will be incidental to "Maintain and Control Traffic".

Place temporary and permanent striping in accordance with Sections 112 and 714, except that:

1. Temporary and permanent striping will be 6" in width; and
2. If the contractor's operations or phasing requires temporary markings which must be subsequently removed from the ultimate pavement, an approved removable lane tape will be used; however removable tape will be measured and paid as Pavement Striping-Temporary Paint 6"; and
3. Edge lines will be required for temporary striping; and
4. Existing, temporary, or permanent striping will be in place before a lane is opened to traffic.
5. Place permanent striping on bridge decks and pavement within the project limits.
6. Permanent striping will be Thermoplastic markings in the asphalt section and Durable Type 1 Markings in the concrete section. Striping will be 6" for lane lines and 12" in the gores.

PAVEMENT EDGE DROP-OFFS

Pavement edge drop-offs will be protected by a lane or shoulder closure. Lane closures will be protected with temporary concrete barrier wall, plastic drums, vertical panels, or barricades unless otherwise directed and/or approved by the Engineer.

A pavement edge between opposing directions of traffic or lanes that traffic is expected to cross in a lane change situation shall not have an elevation difference greater than 1 ½". Place warning signs (MUTCD W8-11 or W8-9A) in advance of and at 1500' intervals throughout the drop-off area. Dual posting on both sides of the traveled way shall be required. Wedge all transverse transitions between resurfaced and unresurfaced areas which traffic may cross with asphalt mixture for leveling and wedging. Remove the wedges prior to placement of the final surface course. Pavement edges that traffic is not expected to cross, except accidentally, shall be treated as follows:

Less than 2" – Protect with a lane closure.

2" to 4" – Protect with a lane closure. Place plastic drums, vertical panels, or barricades every

50 feet. Cones may not be used in place of plastic drums, panels, and barricades at any time. Construct a wedge with compacted cuttings from milling, trenching, or asphalt mixtures with a 3:1 or flatter slope, when work is not active in the drop-off area. Place Type III Barricades at the beginning of the lane closures, and place additional Type III Barricades spaced at 2,500 feet during the time the lane closure is in place.

Greater than 4" – Pavement Repair areas – In areas where pavement is to be removed, work should proceed continuously so that traffic is exposed to a drop-off for the minimum amount of time necessary to bring the pavement back up to existing grade. Barrel spacing should be 20 feet and appropriate lighting should be utilized to illuminate the area during nighttime operations.

Guardrail Installation –All areas from which guardrail is removed shall be protected by a shoulder closure or other method approved by the Engineer until the new guardrail is installed.

TRAFFIC COORDINATOR

Designate an employee to be traffic coordinator. The designated Traffic Coordinator shall meet the requirements described in Section 112.03.12 of the Department's Standard Specifications. The Traffic Coordinator will inspect the project maintenance of traffic once every two hours during the Contractor's operations and at any time a lane closure is in place. The Traffic Coordinator will report all incidents throughout the work zone to the Engineer on the project. The Contractor will furnish the name and a telephone number where the Traffic Coordinator can be contacted at all times.

During any period when a lane closure is in place, the Traffic Coordinator will arrange for personnel to be present on the project at all times to inspect the traffic control, maintain the signing and devices, and relocate Portable Changeable Message Signs as queue lengths change. The personnel will have access on the project to a radio or telephone to be used in case of emergencies or accidents.

COORDINATION OF WORK

The Contractor is advised that other projects may be in progress within or in the near vicinity of this project. The traffic control of those projects may affect this project and the traffic control of this project may affect those projects. The Contractor will coordinate the work on this project with the work of the other contractors. In case of conflict, the Engineer will determine the relative priority to give to work phasing on the various projects.

LAW ENFORCEMENT OFFICERS (LEO'S)

Police support shall be a unit consisting of an off-duty police officer from any police force agency having lawful jurisdiction and a police car equipped with externally mounted flashing blue lights. Officers may be asked to issue citations for traffic violations but will be considered incidental to the contract unit bid price for "Law Enforcement Officer". No additional compensation will be provided. The officers will be placed at the discretion of the Engineer. Police support will be measured and paid on a per hour basis for each officer and police vehicle.

REFERENCES

1. *Kentucky Transportation Cabinet, Department of Highways, Standard Specifications for Road and Bridge Construction, Edition of 2019.*

2. FHWA Manual on Uniform Traffic Control Devices.

3. Active Sepia List

<u>Drawing No.</u>	<u>Drawing Name</u>
006	Inlaid Pavement Marker Arrangements Multi-Lane Roadways
007	Inlaid Pavement Marker Arrangements Multi-Lane Roadways
008	Inlaid Pavement Marker Arrangements Multi-Lane Roadways
011	Inlaid Pavement Marker Arrangement Exit Gore And Off-Ramp
012	Inlaid Pavement Marker Arrangement For Parallel Deceleration Lane
013	Inlaid Pavement Marker Arrangement On-Ramp With Tapered Acceleration Lane
014	Inlaid Pavement Marker Arrangement On-Ramp With Parallel Acceleration Lane

4. Kentucky Department of Highways Standard Drawings, current editions, as applicable:

RBC-003	Guardrail Connector to Bridge End Type A and A-1 Components
RBC-006	Guardrail Connector to Bridge End Type A-1
RBI-001	Typical Guardrail Installations
RBI-002	Typical Guardrail Installations
RBM-020	Delineators for Concrete Barriers
RBR-001	Steel Beam Guardrail ("W" Beam)
RBR-005	Guardrail Components
RBR-015	Guardrail Posts
RBR-016	Guardrail Posts
RBR-025	Guardrail End Treatment Type 2A
RBR-055	Delineators for Guardrail
RDD-021	Flume Inlet Type 2
RDD-040	Channel Lining Class II and III
RDI-041	Erosion Control Blanket Channel Installation
RDP-001	Perforated Pipe Types and Cover Heights
RDP-010	Perforated Pipe Headwalls
RDX-210	Temporary Silt Fence
RGS-002	Superelevation for Multilane Pavement
RGX-001	Miscellaneous Standards Part I
RPN-001	Jointed Plain Concrete Pavement for Shoulders and Medians
RPN-010	Pavement Transitions & Joint Details for Jointed Plain Concrete Pavement at Bridge Ends
RPN-015	Jointed Plain Concrete Pavement
RPN-020	Concrete Pavement Joints Types & Spacing
RPS-010	Concrete Pavement Joints Details
RPS-020	Expansion and Contraction Joint Load Transfer Assemblies
RPS-030	Concrete Pavement Joints Types & Spacing
RPS-031	Concrete Pavement Joints Types & Spacing
RPS-035	Concrete Pavement Joints Types & Spacing
TPM-105	Pavement Marker Arrangements Multi-Lane Roadways
TPM-125	Pavement Marker Arrangement Exit Gore and Off-Ramp
TPM-126	Pavement Marker Arrangement for Parallel Deceleration Lane
TPM-130	Pavement Marker Arrangement On-Ramp with Tapered Acceleration Lane
TPM-135	Pavement Marker Arrangement On-Ramp with Parallel Acceleration Lane
TPM-170	Flexible Delineator Post Arrangements for Horizontal Curves

TPM-171	Flexible Delineator Post Arrangements for Interchange Ramps and Crossovers
TPM-200	Typical Entrance Ramp Markings for Interstates and Parkways
TPM-201	Typical Exit Ramp Markings for Interstates and Parkways
TPM-202	Typical Exit Ramp Markings for Interstates and Parkways
TPM-204	Typical Markings for Gore Areas
TPM-206	Typical Markings for Turn Lanes
TPR-115	Shoulder & Edgeline Rumble Strip Placement Details
TPR-130	Rumble Strip Details Multi-Lane Roadways and Ramps
TTC-115	Lane Closure Multi-Lane Highway Case I
TTC-120	Lane Closure Multi-Lane Highway Case II
TTC-125	Double Lane Closure
TTC-135	Shoulder Closure
TTC-155	Temporary Pavement Marker Arrangements for Construction Zones
TTC-160	Temporary Pavement Marker Arrangements for Lane Closures
TTD-120	Work Zone Speed Limit and Double Fine Signs
TTD-125	Pavement Condition Warning Signs
TTD-130	Speed Zone Signing for Work Zones
TTS-110	Mobile Operation for Paint Striping Case III
TTS-115	Mobile Operation for Paint Striping Case IV
TTS-120	Mobile Operation for Durable Striping Case I
TTS-125	Mobile Operation for Durable Striping Case II

5. *Kentucky Transportation Cabinet, Department of Highways, Standard Specifications for Road and Bridge Construction, Edition of 2019, Supplemental Specifications, as applicable:*

Special Note	Portable Changeable Message Signs
Special Note	Longitudinal Joint Adhesive
Special Note	Guardrail Delivery Verification Sheet
Special Note	Concrete Slurry
Special Note	Asphalt Milling and Texturing
Special Note	Removing Existing Pavement Markers on Concrete Pavement
Special Note	Typical Section Dimensions
Special Note	Before You Dig
Special Note	Fixed Completion Date and Liquidated Damages
Special Note	Modified Full Depth Concrete Pavement Repair
Special Note	Polymer Modified Partial Depth Patching
Special Note	Concrete Pavement Joint and Random Crack Sealing
Special Note	Class 1A Geotextile Fabrics used in Structural Pavement Designs
Special Note	Experimental KYCT and Hamburg Testing
Special Note	Portable Queue Warning Alert System
Special Note	Queue Protection Vehicle
Special Note	Paver Mounted Temperature Profiles
Special Note	Geocomposite Reinforcement for Asphalt

**SPECIAL NOTE FOR
ASPHALT MILLING AND TEXTURING**

Begin paving operations immediately after the commencement of the asphalt milling operations. Continue paving operations continuously until completed. Do not allow public traffic to drive on the milled surface. If paving operations are not begun within this time, liquidated damages will be assessed at the rate prescribed by Section 108.09 of the current Standard Specifications until paving operations are begun.

Removal of the existing pavement markers prior to the milling operation is considered incidental to the bid item "Asphalt Pavement Milling and Texturing".

**SPECIAL NOTE FOR REMOVING EXISTING PAVEMENT MARKERS
ON PORTLAND CEMENT PAVEMENT**

Before diamond grinding, remove existing Type V snow plowable raised pavement markers (iron castings) and patch the hole with Partial Depth Repair Material listed in the Special Note for Partial Depth Concrete Pavement Repair. This material can be diamond ground unless otherwise specified by the manufacturer.

Removal of Type V markers on existing Portland cement pavement will be paid at the contract unit price each, which shall be full compensation for removing the markers and disposing of the castings and any debris. The quantity is estimated by dividing the length of each run of markers by their average spacing (80'), plus one. Actual quantities removed will be verified by the Engineer. Partial Depth Repair Material to repair the resulting recess will be considered incidental to the pay item "Remove Pavement Marker Type V".

SPECIAL NOTE FOR TYPICAL SECTION DIMENSIONS

The dimensions shown on the typical sections for pavement and shoulder widths are nominal or typical dimensions. The actual dimensions to be constructed may be varied to fit existing conditions as directed or approved by the Engineer. It is not intended that existing pavement or shoulders be widened unless specified elsewhere in the Proposal.

SPECIAL NOTE FOR BEFORE YOU DIG

The contractor is instructed to call 1-800-752-6007 to reach KY 811, the one-call system for information on the location of existing underground utilities. The call is to be placed a minimum of two (2) and no more than ten (10) business days prior to excavation. The contractor should be aware that owners of underground facilities are not required to be members of the KY 811 one-call Before-U-Dig (BUD) service. The contractor must coordinate excavation with the utility owners, including those who do not subscribe to KY 811. It may be necessary for the contractor to contact the County Court Clerk to determine what utility companies have facilities in the area.

SPECIAL NOTE FOR FIXED COMPLETION DATE AND LIQUIDATED DAMAGES

No work will be permitted on this project before April 01, 2022 without the approval of the Engineer.

This project has two Fixed Completion Dates.

Contrary to Section 108.09, Liquidated Damages of \$5,000 per calendar day will be assessed for each day or fraction thereof work remains uncompleted beyond the Specified Completion Date for all proposed concrete work on I-64 specified in the proposal. The Fixed Completion Date for all concrete work on I-64 is August 15, 2022.

Contrary to Section 108.09, Liquidated Damages of \$5,000 per calendar day will be assessed for each day or fraction thereof work remains uncompleted beyond the Specified Completion Date for the proposed asphalt work on I-64 and the proposed construction of northbound and southbound I-75 specified in the proposal. The Fixed Completion Date for this work is October 31, 2022

In addition to the Liquidated Damages specified above, Liquidated Damages in the following amounts will be charged when a lane or ramp closure remains in place during the prohibited period outlined in the Traffic Control Plan, excluding delays caused by inclement weather:

Mainline:	\$2,500 for the first hour or fraction thereof \$25,000 any additional hour or fraction thereof
Ramps:	\$2,500 for the first hour or fraction thereof \$10,000 any additional hour or fraction thereof

Note: No additional time will be permitted due to quantity overruns.

These hourly disincentives will still be in effect after the Fixed Completion Date and will be charged in addition to the \$5,000 per calendar day if warranted. The contractor is expected to make every effort to complete the work in order to open the ramp or mainline lane closure within a specified timeframe.

If work is delayed by inclement weather, the minimum work required to allow removal of the lane closure, as directed by the Engineer, shall be resumed immediately as soon as weather permits or the Department will begin to assess Liquidated Damages as specified herein.

Contrary to Section 108.09 of the Standard Specifications, **the disincentive fee will be charged during those periods when seasonal limitations of the Contract prohibit the Contractor from working on a controlling item or operation. This includes the months from December through March.**

All liquidated damages will be applied cumulatively.

All other applicable portions of Section 108 apply.

October 1, 2021

MODIFIED SPECIAL NOTE FOR FULL DEPTH CONCRETE PAVEMENT REPAIR

This Special Note applies to full depth repairs of concrete pavement. Section references herein are to the Department's Standard Specifications for Road and Bridge Construction, current edition.

1.0 DESCRIPTION. Remove and replace concrete pavement. Comply with the applicable Standard Drawings and the Standard Specifications except as specifically superseded herein.

2.0 MATERIALS AND EQUIPMENT.

2.1 JPC Pavement. Test concrete materials according to section 601.03.03. Conform to 501, 502, and 601 except that the concrete must achieve 3000 psi in accordance with Section 4.3 of this note. The Engineer may allow pavement to be opened to traffic at less than 3,000 psi subject to the deductions described in Section 4.3 of this note.

2.2 Dowel Bars and Sleeves. Conform to 811. Contrary to the Standard drawings, 1.5-inch diameter dowel bars will be accepted for 13-inch JPC Pavement and 1.5-inch diameter dowel bars will be required for 10-inch JPC Pavement.

2.3 Tie Bars. Conform to Section 811. Use epoxy coated tie bars in longitudinal and transverse joints.

2.4 Joint Sealants. Conform to Subsection 807.03.01 or 807.03.05.

2.5 Grout Adhesives and Epoxy Resin Systems. Conform to Section 826.

2.6 Dense Graded Aggregate (DGA) and Crushed Stone Base (CSB). Conform to Section 805.

2.7 Geotextile Fabric. Conform to Section 843 and Special Note for Class 1A Geotextile Fabrics.

2.8 Drills. Drill holes using a gang drill, capable of drilling a minimum of four simultaneously. Misalignment of holes shall not exceed 1/4 inch in the vertical or oblique plane.

2.9 Hammers. Only use chisel point hammers weighing less than 40 pounds to remove deteriorated concrete.

3.0 CONSTRUCTION.

3.1 Removal of Existing Pavement. Remove existing pavement to the extent the Contract specifies or as the Engineer directs. The minimum length of patches measured along centerline is 3 feet on each side of an existing joint.

When working with pavements with non-skewed transverse joints, if it is necessary to remove existing pavement closer than 6 feet to a transverse joint, remove the pavement 3 feet beyond that joint .

When working with pavements with skewed transverse joints, if it is necessary to remove existing pavement closer than 3 feet to a transverse joint, remove the pavement 3 feet beyond that joint.

Details of configurations of pavement and joints for various situations are

depicted in the drawings herein.

When small areas of removal and replacement are performed at bridge ends, maintain or reconstruct existing expansion joints at their existing location. When the Engineer determines extensive full width removal and replacement is required, construct new expansion joints at the locations shown on Standard Drawing No. RPN-010.

In the removal operation, make a full depth saw cut longitudinally along the centerline joint and shoulder joint and transversely along the area marked for removal. To prevent damage to the subbase, do not allow the saw to penetrate more than $\frac{1}{2}$ " into the subbase. The Engineer may direct or approve additional cuts within the removal area in order to prevent damage to adjacent pavement remaining in place. Do not overcut beyond the limits of the removal area. Prevent saw slurry from entering existing joints and cracks. To avoid pumping and erosion beneath the slab, do not allow traffic on sawed pavement, unless directed by the Engineer.

Lift out the deteriorated concrete vertically with lift pins. If approved by the Engineer, use other methods that do not damage the base, shoulder, or sides of pavement that is to be left in place. If any damage does occur, saw cut and remove damaged section and if necessary use an acceptable alternative method for the removal process. Any additional costs associated with repair shall be the contractor's responsibility. Do not damage the pavement base during these operations.

Dispose of all removed pavement, cuttings, debris, and other waste off the right-of-way at approved sites obtained by the Contractor at no additional cost to the Department. The Contractor will be responsible for obtaining any necessary permits for this work.

3.2 Pavement Replacement. Do not damage the pavement base during these operations.

3.2.1 Preparation of Base. Compact the new and existing aggregate base to the Engineer's satisfaction. The Engineer will accept compaction by either visual inspection or by nuclear gauge. When the Engineer deems it necessary to stabilize the existing base or replace unsuitable materials, excluding bridge ends, use additional DGA to the depth deemed necessary by the Engineer. Underlay the DGA with FABRIC-GEOTEXTILE CLASS 1A. Flowable fill and cement stabilization may be used as an alternative to stabilize the existing base or to replace unsuitable materials when a plan for such is presented to and approved by the Engineer. At bridge ends, treat existing base and subgrade as the Contract specifies. During compaction, wet the base as the Engineer directs. Compact areas not accessible to compaction equipment by hand tamping.

3.2.2 Underdrains. Construct, or repair damage to, pavement edge drains according to Section 704. If underdrains are placed omitting areas to be patched, construct additional lateral drains as necessary to provide outlets for the installed underdrain until performing the pavement replacement and completing the underdrain system. Provide drainage for any undercut or base repair areas.

3.2.3 Pavement Replacement. Using load transfer assemblies for dowel joints drill into the existing slab according to the details shown herein and on the Standard Drawings.

Use plain epoxy coated dowels of the size specified on the standard drawings based on the pavement thickness for contraction and expansion joints.

Drill holes for dowel bars and tie bars into the face of the existing slab, at a

diameter as specified in the following. Drill the dowel bar holes and tie bar holes to a depth equal to 1/2 the length of the bars. Anchor tie bars into the existing pavement using an epoxy resin. Anchor dowel bars into the existing pavement using either an epoxy resin or an adhesive grout. For tie bars and dowel bars where an epoxy resin is to be used drill the holes 1/8 inch larger than the bar diameter. For dowel bars where an adhesive grout product is to be used, drill holes 1/4 inch larger than the bar diameter. Use a clear or opaque grout retention disk in both grout and epoxy applications. Operate the equipment to prevent damage to the pavement being drilled. Obtain the Engineer's approval of the drilling procedure. Install load transfer assemblies according to the Standard Drawings and Standard Specifications.

When indicated herein or in the Standard Drawings, use 1 inch deformed tie bars that are 18 inches long placed 30 inches on center starting and ending 20 inches inside the edges of the repair area in the longitudinal joint. Use 1 inch deformed tie bars, or plain epoxy coated dowel bars sized in accordance with the Standard Drawings that are 18 inches long beginning 12 inches inside of each edge and on 12-inch centers in transverse construction joints.

Install the dowels and tie bars according to Section 511 unless contradicted here. Ensure the holes are dry and free of dust and debris. Use a nozzle to insert the grout or epoxy starting at the back of the drilled hole to allow for full coating of the dowel or tie bar. After placement, use a bond breaker on the section of the dowel bar that is protruding from the hole.

Mix, place, finish, and cure concrete according to Section 501 with the exception that the Department will allow truck mixing, 2-bag mixers, and hand finishing.

When required, use a form on the side of the slab at longitudinal joints. When the adjacent traffic lane is not closed to traffic or the drop-off is not protected, temporarily fill the space between the form and the adjacent pavement with DGA. After placing the slab, remove the DGA and form. Fill the hole with concrete and thoroughly consolidate by rodding, spading, and sufficient vibration to form a dense homogeneous mass. Use a form on the side of the slab adjacent to shoulders. Excavate and backfill as shown on Section F'-F'.

For patches less than 25 feet in length, use a bond breaker and do not install tie bars at the longitudinal joint. Bond breakers should not exceed 1/8 inch in thickness, e.g. tarpaper.

When resurfacing is required, a float finish is satisfactory. Otherwise, broom finish or, when the adjacent surface has a grooved finish, texture the surface according to Subsection 501.03.13 H). Finish the surface, including joints, to meet a surface tolerance of 1/8 inch in 10 feet that will be verified by straightedge. Cure the pavement and apply curing membranes according to 501.03.15.

Keep all pavement surfaces adjacent to this operation reasonably clean of excess grout and other materials at all times. Maintain all original longitudinal joints. Place transverse joints according to the details shown herein and on the Standard Drawings.

3.3 Joint Sealing. Seal all new or partially new joints with hot-poured elastic joint sealant according to Subsection 501.03.18.

4.0 MEASUREMENT.

4.1 Remove JPC Pavement. The Department will measure the quantity in square yards of surface area. The Department will not measure removal of underlying

base material for payment and will consider it incidental to Remove JPC Pavement.

No separate payment will be made for the disposal of waste from the project or obtaining the necessary permits but will be incidental to the other items of the work.

4.2 DGA or CSB. The Department will measure the quantity used to stabilize the existing base or to replace unsuitable material in tons. The Department will not measure removal of existing base material or underlying material for payment and will consider incidental to DGA or CSB. The quantity of DGA used for the drop-off protection shall be incidental to this work and will not be measured for payment.

4.3 JPC Pavement Non-Reinforced. The Department will measure according to 501.04.01. The Department will not measure dowels, tie bars, or joint sealing for payment and will consider it incidental to Non-Reinforced JPC Pavement.

JPC Pavement will be paid according to section 5.0 below and according to the following payment schedule based on the compressive strength. The cylinders for payment will be tested two hours prior the scheduled opening of traffic.

3000 psi and up	100% payment
2750 to 3000 psi	75% payment and approval from the Engineer to open to traffic*
2500 to 2750 psi	50% payment and approval from the Engineer to open to traffic*
2250 to 2500 psi	25% payment and approval from the Engineer to open to traffic*
Below 2250 psi	10% payment and no potential to open to traffic. Maintain traffic closure until concrete reaches a minimum of 2250 psi.

*If the Engineer approves opening to traffic, the Engineer will evaluate the concrete at 28 days (or sooner) to determine if the removal and replacement of the concrete is necessary due to pavement distress induced by the early opening (i.e. noticeable cracking). If required by the Engineer, remove and replace those slabs showing distress at no cost to the Department.

4.4 Underdrains. The Department will measure the quantity according to Subsection 704.04. The Department will not measure lateral drains for payment and will consider them incidental to the Underdrains.

5.0 PAYMENT. The Department will consider payment as full compensation for all work required in this provision. The Department will make payment for the completed and accepted quantities under the following:

<u>Code</u>	<u>Pay Item</u>	<u>Pay Unit</u>
02091	Remove Pavement	Square Yard
00001	DGA Base	Ton
02069-02088	JPC Pavement	Square Yard
02604	Fabric-Geotextile Class 1A	Square Yard

July 23, 2018

SPECIAL NOTE FOR POLYMER MODIFIED PARTIAL DEPTH PATCHING

DESCRIPTION

This work consists of patching transverse and longitudinal random cracks, centerline joints, contraction joints, longitudinal and transverse expansion joints, holes from pavement markers, or spalled areas in Portland cement concrete pavement.

APPLICATIONS

The installed product shall be a hot applied, flexible mastic sealant made from highly polymer-modified synthetic resins and high quality aggregate. The installed product shall provide a load-transferring repair that has superior tensile strength and flexibility to accommodate joint and crack movement associated with thermal expansion and contraction, and vibratory movements. The patch must have exceptional resistance to water intrusion and to a broad range of salts, bases, and organic materials.

MATERIAL SPECIFICATIONS

<u>PROPERTY</u>	<u>METHOD</u>	<u>REQUIREMENT</u>
Color		Gray
Tensile Strain		29%
Cone Penetration Flow	ASTM D5329	7% Maximum
Aggregate Settlement		3 mm Maximum
Flexibility, lab std. condition	ASTM D3111	No cracking or loss of aggregate adhesion
Impact Testing	ASTM D3111	No cracking, chipping, or separation @ 6ft-lb
Resilience		50% Minimum
Min. Application Temp.		300°F
Max. Heating Temp.		400°F
Specific Gravity	ASTM D5329	1.8 -2.1

SITE PREPARATION

The area to be replaced shall be removed by saw cutting, jackhammering, or milling to the specified width and depth. The repair surfaces will be cleaned and dried with a hot air lance. The recessed area and vertical walls will be treated with a primer agent to promote adhesion and prevent moisture intrusion (for concrete applications only).

INSTALLATION

Installation of the material shall be by factory trained and certified installation professionals and done according to the manufacturer’s recommendations. Installers are to certify that material has not exceeded manufacturer’s assigned expiration date or shelf life.

Heat the material in a thermostatically controlled purpose built mixer, having a horizontal agitator that ensures complete mixing. Once the material has reached the manufacturer’s

July 23, 2018

recommended temperature, the molten material will be introduced into the prepared repair area, sealing the bottom of the repair from water intrusion.

If the depth of the repair exceeds 1 inch, the remainder of the repair process will consist of layering coarse hot angular aggregate (cleaned and dried) at a rate of 25%-35% by volume with the molten material until within $\frac{3}{4}$ " of the top of the repair. The bulking aggregate must be worked into the patch completely.

NO DRY LAYERS OF BULKING AGGREGATE WILL BE ALLOWED.

The final $\frac{3}{4}$ " of the repair will be material for optimum flexibility of the repair. Once this top layer has been screeded to a level grade, apply a high polish stone value (PSV) aggregate to the top of the repair to ensure proper skid resistance.

All removed materials and residual repair materials will be recovered and disposed of away from the site at the Contractor's expense.

DIAMOND GRINDING

If diamond grinding will be required after placing the polymer modified partial depth patch:

1. Repair spalls a minimum of 24 hours before diamond grinding.
2. Assess the size and frequency of repairs to be made. For large spalls where it is possible for more than 1 grinder wheel to be simultaneously on the patched area, fortify the final layer of material. To fortify the top layer add 20-30% structural aggregate to the mastic compound. It is acceptable to leave the top slightly rough since the Diamond Grinding will smooth the surface.
 - a. If the structural aggregate has evidence of moisture, heat and dry the aggregate to 300°F (149°C) in a vented barrel mixer before application. The structural aggregate can be applied after the aggregate has been heated or when the aggregate is at ambient temperature. If Contractor chooses to increase the structural aggregate volume, heating the aggregate prior to application may be necessary to adequately coat the aggregate, eliminate trapped air, and ensure adhesion. Use manufactured suggested aggregate or other aggregate approved by the Engineer.
3. Make sure the final layer of partial depth patching material is covered with surfacing aggregate as specified by the manufacturer.
4. Reduce weight and time grinding.
 - a. Assure that all or most of the wheels on the grinder are on solid pavement when grinding to minimize the load on the patch when grinding.
 - b. When grinding large repairs, float the grinding head to remove the downward load. Have the head or wheels skim the surface of the material to level and smooth the surface without sinking into the material and creating excessive fins.

July 23, 2018

5. Grind over partial depth repairs during the coolest temperatures possible.
Minimize high-ambient temperatures.
6. Keep the grinding head as cool as possible.

MEASUREMENT

The Department will measure the quantity of PARTIAL DEPTH PATCHING-POLYMER MOD in cubic feet, from field measurements or from the metered quantity from the mixer, as determined by the Engineer.

PAYMENT

The Department will make payment for the completed and accepted quantities under the following:

<u>Code</u>	<u>Pay Item</u>	<u>Pay Unit</u>
24997EC	Partial Depth Patching-Polymer Mod	Cubic Foot

The Department will consider payment as full compensation for all work required in this special note.

Acceptable products to meet this specification are Fibrecrete G and Crafcro Techcrete (R or TBR). Other products that fully meet this specification will also be accepted if approved by the Engineer.

SPECIAL NOTE FOR CONCRETE PAVEMENT JOINT AND RANDOM CRACK SEALING

I. DESCRIPTION

Except as specified herein, perform all work in accordance with the Department's 2019 Standard and Supplemental Specifications, Special Notes and Special Provisions, and Standard and Sepia Drawings, current editions, as applicable. Article references are to the Standard Specifications. Furnish all materials, labor, equipment, and incidentals for the following work:

Saw, Clean, and Reseal Longitudinal Joints, Transverse Joints, and Random Cracks.

II. MATERIALS

The Department will sample and test all materials according to the Department's Sampling Manual. Make the materials available for sampling a sufficient time in advance of the use of the materials to allow for the necessary time for testing, unless otherwise specified in these notes.

A. Joint Sealant. Contrary to Section 501.03.18 (B), use hot poured elastic, no alternates.

III. CONSTRUCTION METHODS

A. Site Preparation. Be responsible for all site preparation, including, but not limited to, removal of all obstructions or any other items; disposal of materials; sweeping and removal of debris; and any other incidentals. All site preparation shall be only as approved or directed by the Engineer.

B. Sealing Joints and Random Cracks. Saw cut, clean, and reseal longitudinal, transverse, and random cracks within the project limits as directed by the Engineer. Contrary to Standard Drawing RPX- 015-04, saw cut the joint or crack a minimum of 1/8 inch wider than the existing joint or crack or to the width necessary to provide a clean, new face for a reservoir for the new seal. Except as provided herein, perform all joint and crack sealing according to section 501.03.18(F) except random cracks only need to be routed to a depth of approximately one inch.

IV. METHOD OF MEASUREMENT

Except as provided herein, the Department will measure all work in accordance with the 2019 Standard and Supplemental Specifications, Special Provisions and Special Notes, and Standard and Sepia Drawings, current editions. The Department will measure only the bid items listed. Consider all other items required to complete the work as incidental to the listed items.

A. Site Preparation. Other than the bid items listed, the Department will not measure Site Preparation for payment, but shall be incidental to the other items of the work, as applicable.

B. Saw-Clean-Reseal Joints and Random Cracks. The Department will measure sawed and resealed joints and random cracks in linear feet along the joint or crack. The Department will not measure removing existing joint material or cleaning joints but shall be incidental to Saw-Clean-Reseal Joints and Random Cracks.

V. BASIS OF PAYMENT

The Department will make direct payment only for the bid items listed. Consider all other items required to complete the construction to be incidental to the bid items listed.

A. Saw-Clean-Reseal Joints and Random Cracks. Accept payment at the contract unit price per linear foot of each type as full compensation for all materials, equipment, labor and incidentals necessary to complete the work as specified.

<u>CODE</u>	<u>PAY ITEM</u>	<u>PAY UNIT</u>
02115	Saw-Clean-Reseal Transverse Joint	Linear Foot
02116	Saw-Clean-Reseal Longitudinal Joint	Linear Foot
021173EC	Saw-Clean-Reseal Random Cracks	Linear Foot

September 18, 2019

SPECIAL NOTE FOR CLASS 1A GEOTEXTILE FABRICS USED IN STRUCTURAL PAVEMENT DESIGNS

1. **DESCRIPTION.** This special note covers requirements for Class 1A geotextile fabrics to be used for subgrade stabilization that is a part of a structural pavement design.
2. **GEOTEXTILE FABRIC.** Use woven fabric consisting only of long chain polymeric filaments or yarns such as polypropylene formed into a stable network such that the filaments or yarns retain their relative position to each other. Use fabric that is inert to commonly encountered chemicals and free of defects or flaws significantly affecting its physical or filtering properties.

Ensure that the fabric is formed in widths of at least 6 feet. When necessary, sew sheets of fabric together to form required fabric widths. Sew the sheets of fabric together at the point of manufacture or other approved locations.

The geotextile manufacturer is responsible for establishing and maintaining a quality control program to ensure compliance with this section. The manufacturer must participate in the National Transportation Product Evaluation Program (NTPEP) for Geotextiles and Geosynthetics and the product data must be posted in NTPEP DataMine.

2.1 **PACKING.** During all periods of shipment and storage, wrap the fabric in a heavy duty protective covering to protect the fabric from direct sunlight, ultraviolet rays, temperatures greater than 140 °F, mud, dirt, dust, and debris.

2.2 **PHYSICAL REQUIREMENTS.** Class 1A fabrics are to meet the current requirements of AASHTO M288.

2.3 **ACCEPTANCE.** Obtain the Department's approval for all material before incorporating it into the project.

3. **CONSTRUCTION.** The Engineer will reject the fabric if it has defects, rips, holes, flaws, deterioration, or damage. Prepare the surface to receive the fabric to a smooth condition, free of obstructions, debris, or sharp objects that may puncture the fabric. Place the fabric smooth and free of folds, wrinkles, or creases. Do not operate equipment directly on the fabric. Protect the fabric at all times from contamination. Remove and replace any contaminated fabric with uncontaminated fabric.

Repair or replace any fabric damage. Repair individual isolated cuts, tears, or punctures by placing a patch of geotextile fabric that extends at least 3 feet beyond the damage in all directions or by field splicing the patch. Cover the fabric with a layer of the specified material within 14 calendar days. Remove and replace fabric not covered within 14 days.

September 18, 2019

4. ACCEPTANCE PROCEDURES FOR NON-SPECIFICATION FABRIC. Ensure that all geotextile fabric conforms to the requirements of this section. However, when non-specification geotextile fabric is inadvertently incorporated into the work before completion of testing, the Department may accept the material with a reduction in pay, provided the failure is marginal and will not cause poor performance. When the failure is excessive, then remove the geotextile fabric, and replace it unless the Engineer determines that the geotextile fabric can remain in place. The Department will apply the largest payment reduction when the material fails to meet more than one specification requirement. The Department will calculate the payment reduction on the invoice cost of the material delivered at the project site. The Department will reject geotextile fabric that fails and has not been incorporated into the work.

5. FASTENER PINS. The Engineer will accept fastener pins based on visual inspection on the project. Conform to the following:

5.1 SUBGRADE STABILIZATION AND WRAPPED AGGREGATE DRAINAGE BLANKET. Provide fastener pins that are formed of 3/16 inch diameter or heavier steel, pointed at one end, with a head on the opposite end to retain a washer with a minimum diameter of 1 1/2 inches.

6. MEASUREMENT. The Department will measure the quantity in square yards. The Department will not measure fabric when the Contract indicates the fabric is incidental to the work or when the specification for another item requires incidental installation of geotextile fabric.

The Department will not measure material in laps or seams.

When fabric is used in conjunction with an aggregate layer, the Department will measure the quantity of (1) the area of the lower surface of the aggregate layer, (2) the area of the upper surface of the aggregate layer, and (3) the area of the sides and ends of the aggregate layer; using the dimensions specified in the Plans for each fabric type that applies to its corresponding location(s).

The Department will not measure for payment the repair or replacement of damaged fabric or replacement of fabric not covered within 14 days.

7. PAYMENT. The Department will make payment for the completed and accepted quantities under the following:

<u>Code</u>	<u>Pay Item</u>	<u>Pay Unit</u>
02604	FABRIC-GEOTEXTILE CLASS 1A	Square Yard

SPECIAL NOTE FOR EXPERIMENTAL KYCT AND HAMBURG TESTING

1.0 General

1.1 Description. The KYCT (Kentucky Method for Cracking Test) and the Hamburg test results will help determine if the mixture is susceptible to cracking and rutting. During the experimental phase, data will be gathered and analyzed by the Department to determine the durability of the bituminous mixes. Additionally, the data will help the Department to create future performance based specifications which will include the KYCT and Hamburg test methods.

2.0 Equipment

2.1 KYCT Testing Equipment. The Department will require a Marshall Test Press with digital recordation capabilities. Other CT testing equipment may be used for testing with prior approval by the Department.

2.2 Water Baths. One or more water baths will be required that can maintain a temperature of 77° +/- 1.8° F with a digital thermometer showing the water bath temperature. Also, one water bath shall have the ability to suspend gyratory specimen fully submerged in water in accordance with AASHTO T-166, current edition.

2.3 Hamburg Wheel Track Testing. The department encourages the use of the PTI APA/Hamburg Jr. test equipment to perform the loaded wheel testing. The Department will allow different equipment for the Hamburg testing, but the testing device must be approved by the Department prior to testing.

2.4 Gyratory Molds. Gyratory molds will be required to assist in the production of gyratory specimens in accordance with AASHTO T-312, current edition.

2.5 Ovens. Adequate (minimum of two ovens) will be required to accommodate the additional molds and asphalt mixture necessary to perform the acceptance testing as outlined in Section 402 of the Kentucky Standard Specifications for Road and Bridge Construction, current edition.

2.6 Department Equipment. The Department will provide gyratory molds, PINE 850 Test Press with digital recordation, and CT testing equipment to assist during this experimental phase so data can be gathered. Hamburg test specimens will be submitted to the Division of Materials for testing on the PTI APA/Hamburg Jr if the asphalt contractor or district materials office does not have an approved Hamburg testing device.

3.0 Testing Requirements

3.1 Acceptance Testing. Perform all acceptance testing and aggregate gradation as according with Section 402 and Section 403 of the Kentucky Standard Specifications for Road and Bridge Construction, current edition.

3.2 KYCT Testing. Perform crack resistance analysis (KYCT) in accordance with the current Kentucky Method for KYCT Index Testing during the mix design phase and during the plant production of all surface mixtures. For mix design approvals, submit KYCT results on the Department MixPack. For Class 4 mixtures, submit ingredient materials to the Division of Materials for informational verification.

3.2.1 KYCT Frequency. Obtain an adequate sample of hot mix asphalt to insure the acceptance testing, gradation, and KYCT gyratory samples can be fabricated and is representative of the bituminous mixture. Acceptance specimens shall be fabricated first, then immediately after, fabricate the KYCT samples with the gyratory compactor in accordance with Section 2.4 of this Special Note. Analysis of the KYCT specimens and gradation will be required one per subplot produced from the same asphalt material and at the same time as the acceptance specimen is sampled and tested.

3.2.2 Number of Specimens and Conditioning. Fabricate specimens in accordance with the Kentucky Method for KYCT Index Testing. Contrary to the method, fabricate a minimum of 3 and up to 6 test specimens. The specimens shall be compacted at the temperature in accordance to KM 64-411. KYCT mix design specimens shall be short-term conditioned for four hours at compaction temperature in accordance to KM 64-411. Contrary to the Kentucky Method, plant produced bituminous material shall be short-term conditioned immediately after sampling for two hours at compaction temperature in accordance to KM 64-411. Additionally, fabricated specimens shall be allowed to cool in air (fan is permissible) for 30 minutes +/- 5 minutes and conditioned in a 77 °F water bath for 30 minutes +/- 5 minutes. To insure confidence and reliability of the test results provided by KYCT testing and Hamburg testing, reheating of the asphalt mixture is prohibited.

3.2.3 Record Times. For each subplot, record the time required between drying aggregates in the plant to KYCT specimen fabrication. The production time may vary due to the time that the bituminous material is held in the silo. Record the preconditioning time when the time exceeds the one hour specimen cool down time as required in accordance to The Kentucky Method for KYCT Index Testing. The preconditioning time may exceed an hour if the technician is unable to complete the test on the same day or within the specified times as outlined in The Kentucky Method for KYCT Index Testing. The production time and the preconditioning time shall be recorded on the AMAW.

3.2.4 File Name. As according to section 7.12 of The Kentucky Method for KYCT Index Testing, save the filename with the following format; "CID_Approved Mix Number_Lot Number_Sublot Number_Date"

3.3 Hamburg Testing. Perform the rut resistance analysis (Hamburg) in accordance to AASTHO T-324, not to exceed 20,000 passes for all bituminous mixtures during the mix design phase and production. For mix design approvals, submit Hamburg results on the Department MixPack. For Class 4 mixtures, submit ingredient materials to the Division of Materials for informational verification.

3.3.1 Hamburg Testing Frequency. Perform testing and analysis per lot of material. The plant produced bituminous material sampled for the Hamburg test does not have to be obtained at the same time as the acceptance and KYCT sample. If the Hamburg test sample is not obtained at the same time as the KYCT sample, determine the Maximum Specific Gravity of the KYCT sample in accordance with AASTHO T-209 coinciding with the Hamburg specimens.

3.3.2 Record Times. Record the production time as according to section 3.2.3 in this special note. Also record the time that the specimens were fabricated and the time the Hamburg testing was started. All times shall be recorded on the AMAW.

3.3.3 File Name. Save the Excel spreadsheet with the following file name; “Hamburg_CID_Approved Mix Number_Lot Number_Sublot Number_Date” and upload the file into the AMAW.

4.0 Data

Submit the AMAW and all test data that was obtained for acceptance, gradation, KYCT, and Hamburg testing within five working days once all testing has been completed for a lot to Central Materials Lab and the District Materials Engineer. Also, any data and or comments that the asphalt contractor or district personnel deem informational during this experimental phase, shall also be submitted to the Central Materials Lab and the District Materials Engineer. Any questions or comments regarding any item in this Special Note can be directed to the Central Office, Division of Materials, Asphalt Branch.

5.0 KYCT Video Demonstration

<https://www.youtube.com/watch?v=84j0bM45-hg&feature=youtu.be>

6.0 Payment

Any additional labor and testing equipment that is required to fabricate and test the KYCT and Hamburg specimens shall be considered to be incidental to the asphalt surface line item. The Department will perform the testing for the KYCT and Hamburg specimens if a producer does not possess the proper equipment.

June 3, 2019

Special Note for Portable Queue Warning Alert System

1.0 Description

This item shall consist of furnishing, installing, relocating, operating, servicing, and removing various components of a portable, quickly deployable, real-time automated ITS queue warning alert system (PQWAS), in accordance with the standard specifications and this special provision. The Contractor shall also provide the maintenance of the complete system for the duration of the project or as directed by the Project Engineer. The Department is willing to look at different technologies (i.e. allow the use of crowd sourcing data to be used in lieu of the portable radar sensors). Any changes to the below requirements must be submitted and approved by the Engineer.

2.0 Materials

Materials shall be in accordance as follows:

All materials used shall meet the manufacturer's specifications and recommendations.

All PQWAS materials installed on the project shall be provided by the Contractor in excellent quality condition, shall be corrosion resistant and in strict accordance with all of the details shown within Contractor's Plans approved by KYTC. The Contractor shall maintain an adequate inventory of parts and replacement units to support maintenance and repair of the PQWAS. Pre-deployment is a condition of the system's acceptance and is based on the successful performance demonstration for a (5) day continuous period in accordance to this specification and as set forth in the plans. Ensure compliance to all FCC and Department specifications.

The Contractor shall maintain this system and shall be locally available to service and maintain system components, move portable devices as necessary and respond to emergency situations. The Contractor has oversight responsibility for directing placement of devices in the project area. The Contractor is to be accessible seven (7) days a week and twenty-four (24) hours a day while the system is deployed. The Contractor shall provide contact information for the system's coordinator and others responsible for maintenance of the system prior to installation of the system. Furnish a System Coordinator for monitoring the PQWAS throughout all periods of deployment.

A. General Capabilities and Performance Requirements

1. Overall PQWAS capabilities and performance requirements include the following:
 - a. Furnish a system capable of providing advance traffic information to motorists when there is a queueing of traffic due to congestion resulting from lane reductions, emergency events or other conditions. The condition-responsive notification to the motorist occurs with the use of Portable Changeable Message Signs (PCMS) in accordance to the below capabilities and performance requirements, activated through real-time traffic data collected downstream of the PCMS locations. This equipment must

be a packaged system, pre-programmed and operates as a stand-alone PQWAS meeting this specification. Conditions might exist that require relocation of the portable sensors at any given time, the sensors shall be portable and shall not require re-calibration in the field for fast deployments. Due to the potential need to replace damaged sensors or to change the position of one or more sensors at any given time, sensors must be interchangeable and relocatable by an unskilled laborer. The system must continue to function if as many as half the sensors fail to function.

- b. Provide a PQWAS that consists of the following field equipment: portable radar sensors and portable changeable message signs (PCMS). Provide a system capable of withstanding inclement weather conditions while continuing to provide adequate battery power. The portable radar sensor battery, in a stand-alone state and without a solar panel for recharging, shall be capable of keeping power and capable of sending data for (10) consecutive days or longer. The system shall notify drivers of real-time queue events via specifically placed PCMS units up stream of the work zone. All predetermined/preprogrammed messages are to be approved by KYTC. The number and location of portable radar sensors and PCMS units shall be as directed by the Project Engineer. The decision to deploy or relocate field equipment is made by the Project Engineer and instrumented through the System Coordinator. The decision for equipment removal is made by the Project Engineer after work is complete. The sensors and PCMS units shall be identifiable via global positioning system (GPS) and shall contain an accelerometer to detect and alert of unauthorized movement.
- c. The portable radar sensor shall be capable of collecting traffic speed data. The processed data is used to remotely control PCMS units to display user definable, Engineer approved and locally stored messages. The message trigger state thresholds for slow and stopped speeds shall be user configurable and revisable in less than {1} hour from the Project Engineer's request. Weekly Traffic Data Reports shall be presented to the Project Engineer and shall include speed data per sensor location, travel times, and queue lengths in graphical and numerical formats. In the event the Project Engineer requires a report, other than a weekly report, for any reason; then the Contractor shall provide report within (48) hours of request. Unlimited data reports shall be included within price of system. Sensors shall require no calibration adjustments in the field. Sensor should begin transmitting data within (30) seconds of being turned on. Satellite (SAT) communications will be required when cellular service does not provide continuous communications. Contractor shall identify the most trustworthy cellular provider within the project area.
- d. Data shall be accessible through a website and the Contractor shall provide a username and password for protection. The website shall be accessible seven (7) days a week and twenty - four (24) hours a day. The website shall provide historical & real-time data in graphical and numerical formats and shall have the capability of being integrated within the Department's Traffic Management Center (if requested). The website should be compatible to most hand held devices. Data shall be saved on the manufacturer's network for up to (5) years from the deployment date of system and shall be provided at the request

of the Department at any time within the (5) year window. The use of the website shall be included within the price of system.

- e. Warning Alerts: queue events, low battery voltage warnings, sensor movement alerts, high and low speed alerts shall be provided via cellular text messaging and/or via email messaging at the request of select Contractor personnel and KYTC officials.
- f. The PQWAS system shall have the capabilities to provide alternate route messaging on specifically placed portable changeable message units and/or fixed Variable Message Systems (VMS). The intent of this service is to provide alternate route messaging to motorists before entering the project limits from all directions and giving them appropriate time to adjust their routes. Alternative routes shall be predefined and approved by KYTC. Additional PCMS units may be required for alternate route messaging and will be as per Section 5.0 of this note. KYTC's Traffic Management Center will provide detour messages via fixed VMS units during the term of the project.

B. Portable Radar Sensor Capabilities and Performance Requirements

The PQWAS shall include portable radar sensors (PRD) to monitor and detect queue events.

1. The Radar Sensor shall be FHWA accepted to meet NCHRP 350 test requirements
2. The Radar Sensor shall be locatable at all times via an internal Global Positioning System (GPS) and shall be capable of Cellular or SAT Communications.
3. The Radar Sensor shall have a dry-cell battery capable of powering the system for (10) consecutive days or longer
4. The Radar sensor shall be K-Band technology and have a line of sight up to 200 linear feet without obstruction
5. The Radar sensor shall have the ability to be charged in the field through adaptable solar recharging technology in the case the sensor is utilized for more than 10 consecutive days

C. PCMS Capabilities and Performance Requirements

The PQWAS shall include portable changeable message signs (PCMS) designated to relay automated messaging of queue events, alternate route messages, and caution for the work area defined by the project limits. PCMS placements shall meet the requirements set forth by the Cabinet in each direction of the National Highway System (NHS).

1. The PCMS unit shall be a Full Matrix 24 rows x 50 columns and shall be capable of 1 line, 2line or 3 line messages
2. The PCMS unit shall be legible from a distance over twelve hundred feet (1200')
3. The height and size of characters shall be 18" to 58"
4. The PCMS shall be capable of storing up to 199 pre-programmed messages and up to 199 user-defined messages
5. The PCMS shall have a weather tight control cabinet with back lit LCD handheld controller.
6. The PCMS shall utilize a hydraulic lift to raise the unit to display height
7. The PCMS unit shall include solar recharging ports to allow for recharging of the portable radar sensors when they are not deployed.
8. The PCMS shall be NTCIP compliant and shall have an active Modem with active cellular service.

9. The user shall have the ability to communicate and override the PCMS remotely in the event of an emergency, Amber Alert, etc.
10. The PCMS unit shall have a docking station to include safety rails that allow a commercial safety strap to tie down the portable radar sensors while in transport. The docking station shall hold-up to (4) sensors safely and securely at all times

3.0 Construction Requirements

All communication costs include cellular telephone services, FCC licensing, wireless data networks, satellite and internet subscription charges, and battery charging and maintenance. Additional to these requirements, the Contractor shall assume all responsibility for any and all damaged equipment due to crashes, vandalism, and adverse weather that may occur during the contract period.

The PQWAS shall operate continuously (24 hours/ 7 Days) when deployed on the project. The system is in a constant "data collection" mode when deployed. The Contractor shall provide technical support for the PQWAS for all periods of operation.

In the event communication is lost with any component of the PQWAS, provide a means and staff to manually program a PCMS message. If communication is lost for more the 10 consecutive minutes, the system shall revert to a fail-safe ROADWORK/# MILES/AHEAD message displayed on the PCMS units until communication is restored.

System Operator, local control function and remote management operation must be password protected.

The PQWAS shall be capable of acquiring traffic information and selecting messages automatically without operator intervention after system utilization. The lag time between changes in threshold ranges and the posting of the appropriate PCMS message(s) shall be no greater than (60) seconds. The system operation and accuracy must not be appreciably degraded by inclement weather or degraded visibility conditions including precipitation, fog, darkness, excessive dust, and road debris.

The system shall be capable of storing ad-hoc messages created by the System Coordinator and logging this action when overriding any default or automatic advisory message.

The PQWAS communication system shall incorporate an error detection/correction mechanism to insure the integrity of all traffic conditions data and motorists information messages. Any required configuration of the PQWAS communication system shall be performed automatically during system initialization.

The system's acceptance is based on the successful performance demonstration of PQWAS for a (5) day continuous period in accordance to this specification and as set forth in the plans. Ensure compliance to all FCC and Department specifications.

4.0 Equipment Maintenance.

Maintain system components in good working condition at all times. Repair or replace damaged or malfunctioning components, at no cost to the Department, as soon as possible and within (12) hours of notification by the Engineer. Periodically clean PCMS units if necessary.

5.0 Measurement. The Department will measure each item below in Months. For partial months the Department will pay in 0.25 increments based on the number of calendar days in the below table.

Partial Month Payment Schedule	
Days	Increment
0-7 days	0.25
8-14 days	0.50
15-21 days	0.75
22-31 days	1.00

5.1 Portable Queue Warning Alert System includes cellular (SAT communications will be required if cellular is not available), all supporting field equipment, website, and unlimited data reports accessible by the Engineer. It will be measured by the number of months authorized by the Engineer for use on the project.

5.2 Queue Warning PCMS will be measured by each individual unit multiplied by the number of months authorized by the Engineer for use on the project.

5.3 Queue Warning Portable Radar Sensors will be measured by each individual unit multiplied by the number of months authorized by the Engineer for use on the project. Queue Warning Portable Radar Sensors will not be measured for payment if the Contractor utilizes a system operating on crowd sourcing data. Crowd sourcing data systems will only be allowed as approved by the engineer and will be considered incidental to Portable Queue Warning Alert System.

6.0 Payment.

<u>Code</u>	<u>Pay Item</u>	<u>Pay Unit</u>
26136EC	Portable Queue Warning Alert System	Month
26137EC	Queue Warning PCMS	Month
26138EC	Queue Warning Portable Radar Sensors	Month

Special Note for Traffic Queue Protection Vehicle

- 1.0 DESCRIPTION.** Furnish, Operate, and Maintain Traffic Queue Protection Vehicle at locations and times described herein. The Queue Protection Vehicle is expected to alert motorists (inside and outside of project limits) of all stopped traffic caused by construction activities or incidents within the project limits.
- 2.0 MATERIALS.** The contractor shall provide a minimum of one (1) queue protection vehicle for each traveling direction where traffic flow is reduced or modified in a manner where a queue could occur. One (1) additional queue protection vehicle shall be onsite in reserve. The Traffic Queue Protection Vehicle must fulfill the following minimum requirements:
1. A truck mounted attenuators that meets or exceeds NCHRP TL-3 requirements.
 2. Four (4) round yellow strobe lights (with auto-dimmers) positioned rear facing
 - Two (2) mounted under rear bumper
 - Two (2) mounted at cab level
 - Visibility of strobe lights can not be deterred by attenuator
 3. One (1) standard cab mounted light bar.
 4. A truck mounted message board with a minimum of 3 Lines and 8 Characters per line.
 5. Four Hour National Traffic Incident Management (TIM) Responder Training for Queue Truck Operators.
- 3.0. CONSTRUCTION.** A queue will be defined as anytime that traffic traveling through the project is reduced to a speed of twenty (20) miles per hour or less. The following procedures will be followed when a traffic queue occurs until free flow traffic conditions are present:
- The queue protection vehicle shall be positioned no further than ½ mile upstream from the back of the slow moving traffic.
 - The queue protection vehicle shall be positioned on the shoulder and clear of the traveled way so as not to impede traffic.
 - The queue protection vehicle shall relocate as needed to maintain approximately ½ mile distance from the back of the slow moving traffic.
 - The 2nd queue protection vehicle shall be held in reserve, on site, and support the primary vehicle if conditions prevent repositioning by reverse. This vehicle shall not be paid for idle time.
 - Queue Protection Vehicles shall be kept in project limits during planned lane closures and other project activities expected to cause a queue. One Queue Protection Vehicle shall remain on the project at all times available to respond to incidents within the project limits in a timely manner.
 - Queue length estimates and traffic conditions shall be reported to the KYTC project engineer or designee at the following periods:
 1. At 30 minute intervals
 2. At significant changes
 3. When free flow traffic is achieved
 - The KYTC project engineer or designee will document all daily queue reports and provide these logs to the Director of Maintenance and Director of Construction at the end of each month.

The Queue Protection Vehicle shall be mobilized by the Project Engineer or designee for planned construction activities. For unplanned incidents mobilization should be initiated by the first person (KYTC's or Contractor's project staff) receiving notification of the queue.

4. MEASUREMENT.

4.01 Queue Protection Vehicle. The Department will measure the time from when the vehicle is in position protecting the queue until either free flow traffic is achieved or the vehicle is no longer protecting the queue, whichever occurs first. Idle time will not be paid. The Department will not measure mobilization, removal, maintenance, labor, fuel, or any additional items but will consider them all incidental to this item of work.

4.02 Furnish Queue Protection Vehicles. The Department will measure the quantity by each month the Engineer requires to have the Contractor furnish vehicles as defined in '2.0 Materials' of this Special Note. The Department will not measure mobilization, removal, labor, fuel, or any additional items but will consider them all incidental to this item of work. Partial Months will be calculated as shown in the table below.

Partial Month Payment Schedule	
Days	Increment
0-7 days	0.25
8-14 days	0.50
15-21 days	0.75
22-31 days	1.00

5. PAYMENT.

<u>Code</u>	<u>Pay Item</u>	<u>Pay Unit</u>
25075EC	Queue Protection Vehicle	Hour
25117EC	Furnish Queue Protection Vehicles	Month

Rev 9/2021

SPECIAL NOTE FOR PAVER MOUNTED TEMPERATURE PROFILES

This Special Note will apply when indicated on the plans or in the proposal. Section references herein are to the Department's Standard Specifications for Road and Bridge Construction current edition.

1.0 DESCRIPTION. Provide a paver mounted infrared temperature equipment to continually monitor the temperature of the asphalt mat immediately behind all paver(s) during the placement operations for all mainline pavements (including ramps for Interstates and Parkways) within the project limits. Provide thermal profiles that include material temperature and measurement locations.

2.0 MATERIALS AND EQUIPMENT. In addition to the equipment specified in Subsection 403.02 Utilize a thermal equipment supplier that can provide a qualified representative for on-site technical assistance during the initial setup, pre-construction verification, and data management and processing as needed during the Project to maintain equipment within specifications and requirements.

Provide operator settings, user manuals, required viewing/export software for analysis. Ensure the temperature equipment will meet the following:

(A) A device with one or more infrared sensors that is capable of measuring in at least 1 foot intervals across the paving width, with a minimum width of 12 feet, or extending to the recording limits of the equipment, whichever is greater. A **Maximum of two (2)** brackets are allowed in the influence area under the sensors. A temperature profile must be made on at least 1 foot intervals longitudinally down the road:

(B) Infrared sensor(s):

(1) Measuring from 32°F to 400°F with an accuracy of $\pm 2.0\%$ of the sensor reading.

(C) Ability to measure the following:

(1) The placement distance using a Global Positioning System (GPS) or a Distance Measuring Instrument (DMI) and a Global Positioning System (GPS).

(2) Stationing

(D) GPS: Accuracy ± 4 feet in the X and Y Direction

(E) Latest version of software to collect, display, retain and analyze the mat temperature readings during placement. The software must have the ability to create and analyze:

(1) Full collected width of the thermal profiles,

(2) Paver speed and

(3) Paver stops and duration for the entire Project.

(F) Ability to export data automatically to a remote data server ("the cloud").

At the preconstruction meeting, provide the Cabinet with rights to allow for web access to the data file location. Access to the data is not to be hindered in any way. The Contractor will provide the Cabinet with any vendor specific software, user id, passwords, etc. needed to access the data through this service, cost of this access is incidental to the thermal profile bid item. The Cabinet is to have access to all data as it is being collected. If a third party is used for collecting and distributing the data the Cabinet is to have the same access rights and time as the Contractor.

This web-based software must also provide the Department with the ability to download the raw files and software and to convert them into the correct format.

(G) The thermal profile data files must provide the following data in a neat easy to read table format.

(1) Project information including Road Name and Number, PCN, Beginning and Ending MPs.

(2) IR Bar Manufacturer and Model number

(3) Number of Temperature Sensors (N)

(4) Spacing between sensors and height of sensors above the asphalt mat

(5) Total number of individual records taken each day (DATA BLOCK)

- (a) Date and Time reading taken
- (b) Latitude and Longitude
- (c) Distance paver has moved from last test location
- (d) Direction and speed of the paver
- (e) Surface temperature of each of the sensors

3.0 CONSTRUCTION. Provide the Engineer with all required documentation at the pre-construction conference.

(A) Install and operate equipment in accordance with the manufacturer’s specifications.

(B) Verify that the temperature sensors are within ± 2.0% using an independent temperature device on a material of known temperature. Collect and compare the GPS coordinates from the equipment with an independent measuring device.

(1) Ensure the independent survey grade GPS measurement device is calibrated to the correct coordinate system (using a control point), prior to using these coordinates to validate the equipment GPS.

(2) The comparison is considered acceptable if the coordinates are within 4 feet of each other in the X and Y direction.

(C) Collect thermal profiles on all Driving Lanes during the paving operation and transfer the data to the “cloud” network or if automatic data transmission is not available, transfer the data to the Engineer at the end of daily paving.

(D) Contact the Department immediately when System Failure occurs. Daily Percent Coverage will be considered zero when the repairs are not completed within two (2) working days of System Failure. The start of this two (2) working day period begins the next working day after System Failure.

(E) Evaluate thermal profile segments, every 150 feet, and summarize the segregation of temperature results. Results are to be labeled as Minimal 0°-25°F, Moderate 25.1°-50°F and Severe >50°. Severe readings over 3 consecutive segments or over 4 or more segments in a day warrant investigation on the cause of the differential temperature distribution.

4.0 MEASUREMENT. The Department will measure the total area of the pavement lanes mapped by the infrared scanners. Full payment will be provided for all lanes with greater than 85% coverage. Partial payment will be made for all areas covered from 50% coverage to 85% coverage at the following rate Coverage area percentage X Total bid amount. And area with less than 50% coverage will not be measured for payment.

5.0 PAYMENT. The Department will make payment for the completed and accepted quantities under the following:

1. Payment is full compensation for all work associated with providing all required equipment, training, and documentation.
2. Delays due to GPS satellite reception of signals or equipment breakdowns will not be considered justification for contract modifications or contract extensions.

<u>Code</u>	<u>Pay Item</u>	<u>Pay Unit</u>
24891EC	PAVE MOUNT INFRARED TEMP EQUIPMENT	SQFT

FAYETTE CO. I-75 NB ~m.p. 108.80; SB ~m.p. 109.06
 NB ~LAT/LONG N 38.02855, W 84.41744
 SB ~LAT/LONG N 38.03178, W 84.42002
 STATION 250

SITE LOCATION IS APPROXIMATE AND WILL BE DETERMINED IN THE FIELD AND APPROVED BY DIVISION OF PLANNING PERSONNEL PRIOR TO ANY CONSTRUCTION.

ALL LOOPS SHALL BE 6'X6' SQUARE AND SHALL BE INSTALLED 16' FROM LEADING EDGE TO LEADING EDGE AS SHOWN. PIEZOELECTRIC SENSORS (PIEZOS) SHALL BE INSTALLED 5' FROM THE EDGE OF LOOPS WITH THE EDGE OF EACH PIEZO FLUSH WITH THE EDGE OF THE CORRESPONDING DRIVING LANE. LOOPS AND PIEZOS SHALL BE INSTALLED SPlice-FREE TO THE CABINET AND A MINIMUM OF 2' OF WIRE FOR EACH SENSOR SHALL BE COILED INSIDE EACH JUNCTION BOX AND EACH CABINET. ALL LOOPS AND PIEZOS SHALL BE LABELED IN ALL JUNCTION BOXES AND CABINET. DIVISION OF PLANNING PERSONNEL WILL CONNECT THE LOOPS AND PIEZOS INSIDE THE CABINET.

INSTALL ONE (1) 1/4" CONDUIT FROM EACH SAW SLOT TO NEAREST JUNCTION BOX.

INSTALL TWO (2) TYPE A JUNCTION BOXES (JB A1 AND A2)

INSTALL TWO (2) 20"x20"x8" CABINETS MOUNTED TO TWO (2) WOOD POSTS EACH (ONE ON EACH SIDE OF THE ROADWAY).

REMOVE ANY AND ALL EX. TRAFFIC DATA COLLECTION EQUIPMENT AND DISPOSE OF OFF THE JOBSITE.

CODED NOTE:

- ① INSTALL ONE (1) 2" CONDUIT.

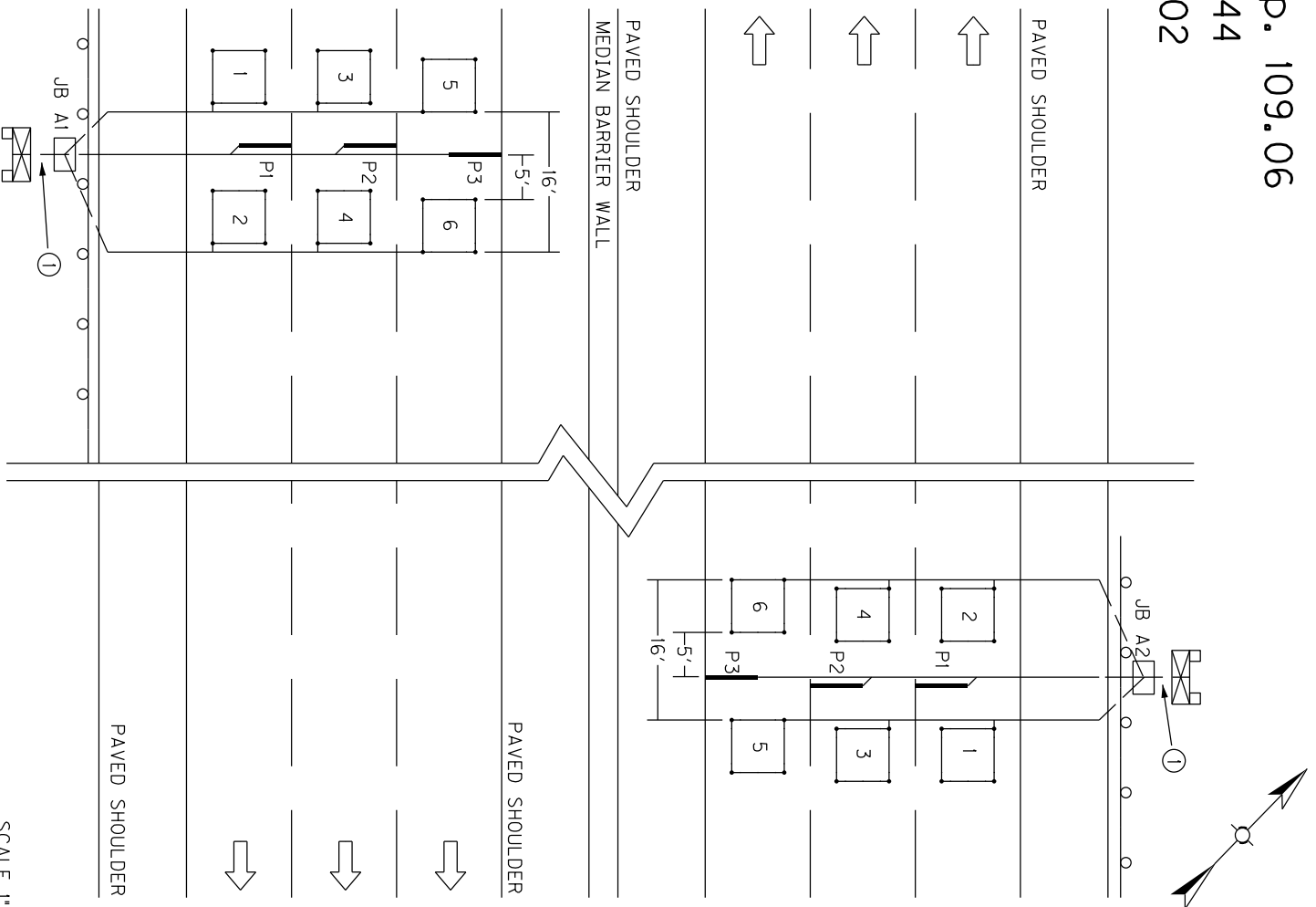

SCALE 1"=20'

FAYETTE CO. I-75 ~m.p. 110.21
~LAT/LONG N 38.04754, W 84.42323
STATION 392

SENSOR LOCATIONS ARE SCHEMATIC ONLY AND SHALL BE DETERMINED IN THE FIELD AND APPROVED BY DIVISION OF PLANNING PERSONNEL PRIOR TO ANY CONSTRUCTION.

ALL LOOPS SHALL BE 6'X6' SQUARE AND SHALL BE INSTALLED 16' FROM LEADING EDGE TO LEADING EDGE AS SHOWN. PIEZOELECTRIC SENSORS (PIEZOS) SHALL BE INSTALLED 5' FROM THE EDGE OF LOOPS WITH THE EDGE OF EACH PIEZO FLUSH WITH THE EDGE OF THE CORRESPONDING DRIVING LANE. LOOPS AND PIEZOS SHALL BE INSTALLED SPLICE-FREE TO THE CABINET AND A MINIMUM OF 2' OF WIRE FOR EACH SENSOR SHALL BE COILED AND LABELED INSIDE EACH JUNCTION BOX AND CABINET. DIVISION OF PLANNING PERSONNEL WILL CONNECT THE LOOPS AND PIEZOS INSIDE THE CABINETS.

INSTALL ONE (1) 1/4" CONDUIT FROM EACH SAW SLOT TO NEAREST JUNCTION BOX.

INSTALL TWO (2) TYPE A JUNCTION BOXES (JB A1 AND A2).

INSTALL TWO (2) 20"X20"X8" CABINET MOUNTED TO TWO (2) WOOD POSTS EACH.

REMOVE ANY AND ALL EX. TRAFFIC DATA COLLECTION EQUIPMENT AND DISPOSE OF OFF THE JOBSITE.

CODED NOTE:

① INSTALL ONE (1) 2" CONDUIT.

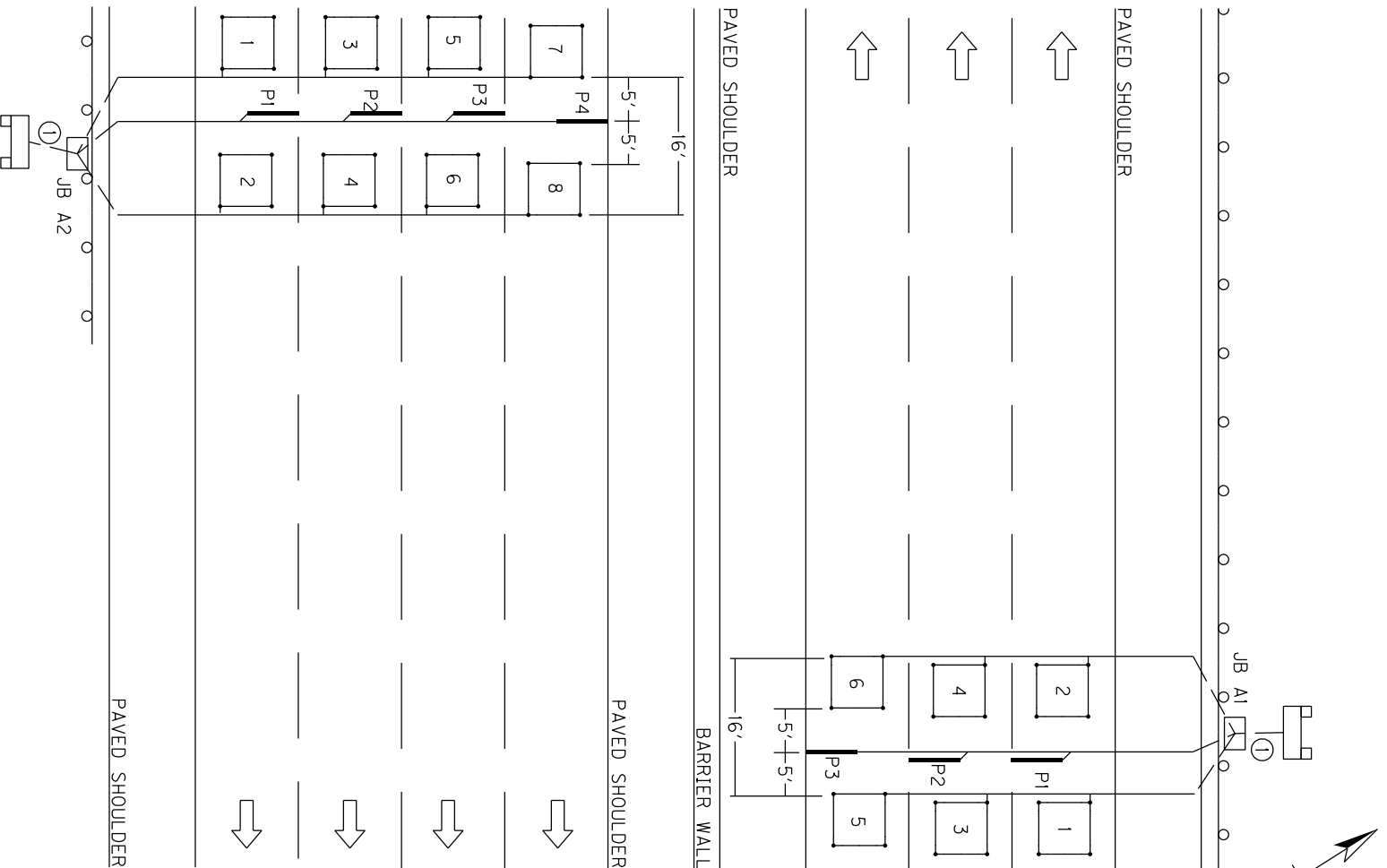

Permanent Traffic Data Acquisition Station
Estimate Of Quantities

Revised February 2019

**PERMANENT TRAFFIC DATA ACQUISITION STATIONS
ESTIMATE OF QUANTITIES**

Bid Item Code	Description	Unit	Quantity
4793	CONDUIT 1 ¼ INCH	LIN FT	160
4795	CONDUIT 2 INCH	LIN FT	40
4811	ELECTRICAL JUNCTION BOX TYPE B	EACH	
4820	TRENCHING AND BACKFILLING	LIN FT	180
4821	OPEN CUT ROADWAY	LIN FT	
4829	PIEZOELECTRIC SENSOR	EACH	13
4830	LOOP WIRE	LIN FT	5900
4833	WIRE – NO. 8	LIN FT	
4834	WIRE – NO. 6	LIN FT	
4850	CABLE NO. 14/1 PAIR	LIN FT	
4871	POLE – 35’ WOODEN	EACH	
4895	LOOP SAW SLOT AND FILL	LIN FT	1190
4899	ELECTRICAL SERVICE	EACH	
20213EC	INSTALL PAD MOUNT ENCLOSURE	EACH	
20359NN	GALVANIZED STEEL CABINET	EACH	4
20360ES818	WOOD POST	EACH	8
20391NS835	ELECTRICAL JUNCTION BOX TYPE A	EACH	4
20392NS835	ELECTRICAL JUNCTION BOX TYPE C	EACH	
20468EC	ELECTRICAL JUNCTION BOX 10x8x4	EACH	
21543EN	BORE AND JACK CONDUIT	LIN FT	
23206EC	INSTALL CONTROLLER CABINET	EACH	

MATERIAL, INSTALLATION, AND BID ITEM NOTES FOR PERMANENT TRAFFIC DATA ACQUISITION STATIONS

1. DESCRIPTION

Except as specified in these notes, all work shall consist of furnishing and installing all materials necessary for permanent data acquisition station equipment installation(s) and shall be performed in accordance with the current editions of:

- The Contract
- Division of Planning Standard Detail Sheets
- Kentucky Transportation Cabinet, Department of Highways, *Standard Specifications for Road and Bridge Construction*
- Kentucky Transportation Cabinet, Department of Highways, Standard Drawings
- National Fire Protection Association (NFPA) 70: *National Electrical Code*
- Institute of Electrical and Electronic Engineers (IEEE), *National Electrical Safety Code*
- Federal Highway Administration, *Manual on Uniform Traffic Control Devices*
- American Association of State Highway and Transportation Officials (AASHTO), *Roadside Design Guide*.
- Standards of the utility company serving the installation, if applicable

The permanent traffic data acquisition station layout(s) indicate the extent and general arrangement of the proposed installation and are for general guidance. Any omission or commission shown or implied shall not be cause for deviation from the intent of the plans and specifications. Information shown on the plans and in this proposal and the types and quantities of work listed are not to be taken as an accurate or complete evaluation of the material and conditions to be encountered during construction. The bidder must draw his own conclusion as to the conditions encountered. The Department of Highways (Department) does not give any guarantee as to the accuracy of the data and no claim will be considered for additional compensation if the conditions encountered are not in accordance with the information shown. If any modifications of the plans or specifications are considered necessary by the Contractor, details of such modifications and the reasons, therefore, shall be submitted in writing to the Engineer for written approval prior to beginning such modified work.

The Contractor shall contact all utility companies and the district utility agent prior to beginning construction to insure proper clearance and shielding from existing and proposed utilities. The Contractor shall use all possible care in excavating on this project so as not to disturb any existing utilities whether shown on the plans or not shown on the plans. Any utilities disturbed or damaged by the Contractor during construction shall be replaced or repaired to original condition by the Contractor at no cost to the department. If necessary, to avoid existing utilities, the Contractor shall hand dig areas where poles or conduit cross utilities.

Material, Installation, and Bid Item Notes for
Permanent Traffic Data Acquisition Stations

Revised August, 2018

The Contractor shall be responsible for all damage to public and/or private property resulting from his work.

The Contractor shall inspect the project site prior to submitting a bid and shall be thoroughly familiarized with existing conditions. Submission of a bid will be considered an affirmation of this inspection having been completed. The Department will not honor any claims resulting from site conditions.

2. MATERIALS

All proposed materials shall be approved prior to being utilized. The Contractor shall submit for material approval an electronic file of descriptive literature, drawings and any requested design data for the proposed materials. After approval, no substitutions of any approved materials may be made without the written approval of the Engineer.

Materials requiring sampling shall be made available a sufficient time in advance of their use to allow for necessary testing.

2.1. Anchoring

2.1.1. Anchor and Anchor Rod

Anchor, except rock anchor, shall be expanding type, with a minimum area of 135 square inches.

Anchor rod shall be galvanized steel, double-eye, have a minimum diameter of 5/8 inches, and a minimum length of 84 inches. Minimum holding capacity shall be 15,400 lbs.

Rock anchor shall be galvanized steel, triple-eye, expanding type, with a minimum diameter of 3/4 inch, a minimum 53 inches long, and a minimum tensile strength of 23,000 lb.

2.1.2. Guy Wire and Guy Guard

Guy wire shall be Class A, Zinc-coated, 3/8 inch diameter, high strength grade steel (minimum 10,800 lb.) and galvanized per ASTM A475. Guy guard shall be 8' long, fully-rounded, yellow, and able to be securely attached to the guy wire.

2.1.3. Strandwise for Guy Wire

Strandwise for guy wire shall be 3/8 inch and rated to hold a minimum of 90% of the rated breaking strength (RBS) of the strand used.

2.2. Asphalt

Asphalt shall be a minimum CL2 Asph Surf 0.38C PG64-22 and conform to the *Standard Specifications for Road and Bridge Construction*.

2.3. Backer Rod

Backer rod shall be 1/2 inch diameter, closed cell polyethylene foam and shall meet or exceed the following physical properties:

- Density (average): 2.0 lbs/cu.ft. (minimum): ASTM D 1622 test method
- Tensile Strength: 50 PSI (minimum): ASTM D 1623 test method
- Compression Recovery: 90% (minimum): ASTM D 5249 test method
- Water Absorption: 0.03 gm/cc (maximum): ASTM C 1016 test method

2.4. Cabinets

2.4.1. Galvanized Steel Cabinet

Galvanized Steel Cabinet shall be constructed of 16 or 14 gauge galvanized steel and shall meet or exceed the industry standards set forth by UL 50 and NEMA 3R. The finish shall be an ANSI 61 gray polyester powder finish inside and out over the galvanized steel. Cabinet shall have minimum inside dimensions of 20 inches high by 20 inches wide by 8 inches deep.

The cabinet shall be equipped with the following:

- Drip shield top
- Seam-free sides, front, and back, to provide protection in outdoor installations against rain, sleet, and snow
- Hinged cover with 16 gauge galvanized steel continuous stainless steel pin.
- Cover fastened with captive plated steel screws, knob or latch
- Hasp and staple for padlocking
- No gaskets or knockouts
- Back panel for terminal block installation
- Post mounting hardware
- Terminal Blocks

2.4.2. Anchor Bolt for Pad Mounted Cabinet

Anchor bolt for pad mounted cabinet shall be galvanized steel with minimum dimensions of 3/8 inch by 6 inches.

2.5. Concrete

Concrete shall be Class A and conform to the *Standard Specifications for Road and Bridge Construction*.

2.6. Conduit and Conduit Fittings

Conduit and conduit fittings shall be rigid steel unless otherwise specified.

Conduit shall be zinc galvanized inside and out and conform to the NEC, UL Standard 6, and ANSI C-80.1.

Rigid Steel Conduit Fittings shall be galvanized inside and out and conform to the NEC, UL Standard 514B, and ANSI C-80.4. Intermediate Metal Conduit (IMC) will not be approved as an acceptable alternative to rigid steel conduit.

2.7. Conduit sealant

Conduit sealant shall be weather-, mold-, and mildew-resistant and chemically resistant to gasoline, oil, dilute acids and bases. Conduit sealant shall be closed cell type and shall meet or exceed the following properties:

- Cure Time 20 minutes max.
- Density 64.4 kg/m³; 6 lbs/ft³
- Compressive Strength (ASTM 1691) 13.8 MPa; 330 or 300 psi

- Tensile Strength (ASTM 1623) 15.9 MPa; 270 or 250 psi
- Flexural Strength (ASTM D790) 14.5 MPa; 460 or 450 psi
- Service Temperature -20 to 200 F

2.8. Electrical Service Meter Base

Electrical service meter base shall meet or exceed all requirements of the National Electrical Code and the local utility providing the electrical service.

2.9. Electrical Service Disconnect

Electrical service disconnect shall meet or exceed all requirements of the National Electrical Code and the local utility providing the electrical service.

2.10. Flashing Arrow

Flashing Arrow shall conform to the *Standard Specifications for Road and Bridge Construction*.

2.11. Ground Fault Circuit Interrupter (GFCI) Receptacle

Ground Fault Circuit Interrupter Receptacle shall be 2-pole, 3-wire, 20 Amp, 125 Volt, 60 Hz, NEMA 5-20R configuration and meet or exceed the following standards and certifications:

- NEMA WD-1 and WD-6
- UL 498 and 943
- NOM 057
- ANSI C-73

This item shall include a UL listed, 4 inch x4 inch x 2¹/₈ inch box with ³/₄ inch side and end knockouts and a 1¹/₂ inches deep, single-receptacle cover to house the GFCI receptacle. Box and cover shall be hot rolled, galvanized steel with a minimum thickness of 0.62 inches.

2.12. Grounding

2.12.1. Ground Rod

Ground Rod shall be composite shaft consisting of a pure copper exterior (5 mil minimum) that has been inseparably molten welded to a steel core. Ground Rod shall have a minimum diameter of 5/8 inch, a minimum length of 8 feet and shall be manufactured for the sole purpose of providing electrical grounding.

2.12.2. Ground Rod Clamp

Ground rod shall be equipped with a one piece cast copper or bronze body with a non-ferrous hexagonal head set screw and designed to accommodate a 10 AWG solid through 2 AWG stranded grounding conductor.

2.13. Grout

2.13.1. Grout for Inductive Loop Installation

Grout for inductive loop installation shall be non-shrink, shall meet the requirements of the *Standard Specifications for Road and Bridge Construction*,

and shall be included on the KYTC Division of Materials, *List of Approved Materials*.

2.13.2. Grout for Piezoelectric Sensor Installation

Grout for piezoelectric sensor installation shall be per the piezoelectric sensor manufacturer's recommendation. Grout shall be suitable for installation in both asphalt and Portland cement pavements. Grout shall have a short curing time (tack free in ten minutes; open to traffic in forty minutes; and fully cured within sixty minutes) to prevent unnecessary lane closure time and should be of sufficient consistency to prevent running when applied on road surfaces with a drainage cross slope. Particulate matter within the grout shall not separate or settle and the grout shall not shrink during the curing process.

2.14. Hardware

Except where specified otherwise, all hardware such as nuts, bolts, washers, threaded ends of fastening devices, etc. with a diameter less than 5/8 inch shall be passivated stainless steel, alloy type 316 or type 304. Stainless steel hardware shall meet ASTM F593 and F594 for corrosion resistance. All other nuts and bolts shall meet ASTM A307 and shall be galvanized.

2.14.1. Conduit Strap

Conduit strap shall be double-hole, stainless steel, and sized to support specified conduit. Conduit strap shall attach to wood pole or post with two 2 1/4 inch wood screws.

2.14.2. Mounting Strap for Pole Mount Cabinet

Mounting strap for pole mount cabinet shall be 3/4 inch x 0.03 inch stainless steel; equipped with clips or buckles to securely hold strap.

2.14.3. Metal Framing Channel and Fittings

Metal framing channel shall be 1 5/8 inches wide galvanized steel that conforms to ASTM A1011 and ASTM A653. One side of the channel shall have a continuous slot with in-turned edges to accommodate toothed fittings.

Fittings shall be punch pressed from steel plates and conform to ASTM A575 and the physical requirements of ASTM A1011.

2.15. Junction Box

2.15.1. Junction Box Type A, B, or C

Junction Box Type A, B, or C shall meet or exceed ANSI/SCTE 77-2007, Tier 15. Box shall have an open bottom. A removable, non-slip cover marked "PLANNING" shall be equipped with a lifting slot and attached with a minimum of two 3/8 inch stainless steel hex bolts and washers. Type A Box shall have nominal inside dimensions of 13 inches wide by 24 inches long by 18 inches deep. Type B Box shall have nominal inside dimensions of 11 inches wide by 18 inches long by 12

inches deep. Type C Box shall have nominal inside dimensions of 24 inches wide by 36 inches long by 30 inches deep.

2.15.2. Aggregate for Junction Box Type A, B, or C

Aggregate for junction box type A, B, or C shall be gradation size no. 57 and conform to the *Standard Specifications for Road and Bridge Construction*.

2.15.3. Junction Box 10x8x4

Junction Box Type 10x8x4 shall be constructed of a UV-stabilized, nonmetallic material or non-rusting metal and be weatherproof in accordance with NEMA 4X. Box shall be equipped with an overhanging door with a continuous durable weatherproof gasket between the body and door. Door shall be hinged with screws, hinge(s) and pin(s) and shall be equipped with a padlockable latch on the side opposite the hinge(s). Junction Box 10x8x4 shall have minimum inside dimensions of 10 inches high by 8 inches wide by 4 inches deep.

2.16. Maintain and Control Traffic

Materials for the bid item Maintain and Control Traffic shall conform to the *Standard Specifications for Road and Bridge Construction*, and the KYTC Department of Highways *Standard Drawings*.

2.17. Piezoelectric Sensor

Piezoelectric sensor (piezo) shall provide a consistent level voltage output signal when a vehicle axle passes over it, shall have a shielded transmission cable attached, and shall meet the following requirements:

- Dimensions: such that sensor will fit in a ¾ inch wide by 1 inch deep saw cut. Total length shall be 6 feet unless specified otherwise.
- Output uniformity: ± 7% (maximum)
- Typical output level range: 250mV (minimum) from a wheel load of 400 lbs.
- Working temperature range: -40° to 160° F.
- Sensor life: 30 million Equivalent Single Axle Loadings (minimum)

Shielded transmission cable shall be coaxial and shall meet the following requirements:

- RG 58C/U with a high density polyethylene outer jacket rated for direct burial
- Length shall be a minimum of 100 feet. Installations may exceed 100 feet so the piezo shall be supplied with a lead-in of appropriate length so that the cable can be installed splice-free from the piezo to the cabinet.
- Soldered, water resistant connection to the sensor.

One installation bracket for every 6 inches of sensor length shall also be supplied. Piezo shall be a RoadTrax BL Class I or approved equal.

2.18. Saw Slot Sealant

Saw Slot Sealant shall be non-shrink, non-stringing, moisture cure, polyurethane

encapsulant suitable for use in both asphalt and concrete pavements. It shall provide a void-free encapsulation for detector loop cables and adequate compressive yield strength and flexibility to withstand heavy vehicular traffic and normal pavement movement.

The cured encapsulant shall meet or exceed the following:

- Hardness (Indentation): 35-65 Shore A, ASTM D2240
- Tensile Strength: 150 psi minimum, ASTM D412
- Elongation: 125% minimum 2 inch/minute pull, ASTM D412
- Tack-free Drying Time: 24 hours maximum, ASTM C679
- Complete Drying Time: 30 hours maximum, KM 64-447
- Chemical Interactions (seven day cure at room temperature, 24-hour immersion, KM 64-446):
 - Motor Oil: No effect
 - Deicing Chemicals: No effect
 - Gasoline: Slight swell
 - Hydraulic Brake Fluid: No effect
 - Calcium Chloride (5%): No effect

2.19. Seeding and Protection

Material for Seeding and Protection shall be Seed Mixture Type I and conform to the *Standard Specifications for Road and Bridge Construction*.

2.20. Signs

Materials for signs shall conform to the *Standard Specifications for Road and Bridge Construction*.

2.21. Splicing Materials

2.21.1. Electrical Tape

Electrical tape shall be a premium grade, UL-listed, all-weather, vinyl-insulating tape with a minimum thickness of 7 mil. Tape shall be flame retardant and resistant to abrasion, moisture, alkalis, acids, corrosion, and weather (including ultraviolet exposure).

2.21.2. Splice Kit

Splice kit shall be inline resin-type and rated for a minimum of 600V. Resin shall be electrical insulating-type and shall provide complete moisture and insulation resistance.

2.22. Steel Reinforcing Bar

Steel reinforcing bar shall be #5 and shall conform to the *Standard Specifications for Road and Bridge Construction*.

2.23. Terminal Block

Terminal block shall be rated for a minimum of 300 V and have a minimum of six

terminal pairs with 9/16-inch nominal spacing (center to center) for connecting loop and piezoelectric sensor wires to cable assemblies. Terminal block shall have screw type terminal strips to accommodate wire with spade-tongue ends.

2.24. Warning Tape

Warning tape shall be acid and alkali resistant formulated for direct burial. Tape shall be a minimum of 3 inches wide by 4.0 mils (nominal) thick, and shall be permanently imprinted with a minimum 1 inch black legend on a red background warning of an electric line. Tape shall meet or exceed the following industry specifications:

- American Gas Association (AGA) 72-D-56
- American Petroleum Institute (API) RP 1109
- American Public Works Association (APWA) Uniform Color Code
- Department of Transportation (DOT) Office of Pipeline Safety USAS B31.8
- Federal Gas Safety Regulations S 192-321 (e)
- General Services Administration (GSA) Public Buildings Service Guide: PBS 4-1501, Amendment 2
- National Transportation Safety Board (NTSB) PSS 73-1
- Occupational Safety and Health Administration (OSHA) 1926.956 (c) (1)

2.25. Wire and Cable

All cable and wire shall be plainly marked in accordance with the National Electrical Code (NEC).

2.25.1. Loop Wire

Loop wire shall be 14 AWG, stranded, copper, single conductor, and shall conform to the International Municipal Signal Association (IMSA) Specification No. 51-7.

2.25.2. Cable No. 14/1 Pair

Cable No. 14/1 pair loop lead-in cable shall be 14 AWG, stranded, copper paired, electrically shielded conductors, and shall conform to IMSA 19-2.

2.25.3. Grounding conductor

Grounding conductor and bonding jumper shall be solid or stranded, 4 AWG bare copper.

2.25.4. Service Entrance Conductor

Service entrance conductor shall be stranded, copper, Type USE-2, sized as required to comply with the NEC.

2.25.5. Terminal for electrical wire or cable

Terminal for electrical wires or cables shall be insulated, solderless, spade tongue terminals of correct wire and stud size. Terminal for electrical wires or cables shall be incidental to the wire or cable (including piezoelectric sensor transmission cable) to be connected to terminal strips.

2.26. Wood Post

Wood post shall be Southern Pine pretreated to conform to the American Wood Preservers' Association (AWPA) C-14 or UC4B and shall have minimum dimensions of 4 inches by 4 inches by 8 feet long (for Galvanized Steel Cabinet) or 4 feet long (for Junction Box 10x8x4), sawed on all four sides with both ends square.

2.27. Wooden Pole

Wooden pole shall be a Class IV wood pole of the length specified and shall conform to the *Standard Specifications for Road and Bridge Construction* except the pole shall be treated in accordance with AWPA P9 Type A.

3. CONSTRUCTION METHODS

The plans indicate the extent and general arrangement of the installation and are for guidance. When the Contractor deems any modifications to the plans or specifications necessary, details of such changes and the reasons shall be submitted in writing to the engineer for written approval prior to beginning the modified work.

After the project has been let and awarded, the Division of Construction shall notify the Division of Planning of the scheduled date for a Pre-Construction meeting so that prior arrangements can be made to attend. This will allow the Division of Planning an opportunity to address any concerns and answer any questions that the Contractor may have before beginning the work.

The Division of Planning Equipment Management Team (502-564-7183) shall be notified a minimum of seven days before any work pertaining to these specifications begins to allow their personnel the option to be present during installation.

Unless otherwise specified, installed materials shall be new.

Construction involving the installation of loops or piezoelectric sensors shall not be performed when the temperature of the pavement is less than 38°F.

A final inspection will be performed by a member of the Central Office Division of Planning equipment staff after the installation is complete to verify that the installation is in compliance with the plans and specifications.

Any required corrective work shall be performed per the *Standard Specifications for Road and Bridge Construction*.

3.1. Anchoring

Furnish: Anchor, anchor rod, guy wire, strand vise, guy guard.

Anchor shall be installed in relatively dry and solid soil. Rock anchor shall be installed in solid rock. Excavate the hole at a 45° to 60° angle in line with the guy (hole size shall be slightly larger than the expanded anchor – see manufacturer's recommendation). Attach rod to anchor, install assembly into hole, and expand anchor. Backfill and tamp entire disturbed area. The effectiveness of the anchor is dependent upon the thoroughness of backfill tamping. Attach guy to strand vise on pole and anchor rod and tighten to required tension. Install guy guard on guy.

3.2. Bore and Jack Pipe – 2”

Furnish: Steel Encasement Pipe, 2”

Bore and jack pipe – 2” shall conform to the Section 706 of the *Standard Specifications for Road and Bridge Construction*.

3.3. Cleanup and Restoration

Furnish: Seed Mix Type 1 (as required); fertilizer (as required); agricultural limestone (as required); mulch or hydromulch (as required); tackifier (as required).

The Contractor shall be responsible for repairing any damage to public and/or private property resulting from his work. Upon completion of the work, restore all disturbed highway features in like kind design and materials. This shall include filling any ruts and leveling ground appropriately. Contractor shall dispose of all waste and debris off the project. Sow all disturbed earthen areas with Seed Mix Type 1 per Section 212 of the *Standard Specifications for Road and Bridge Construction*. All materials and labor necessary for cleanup and restoration shall be considered incidental to other bid items.

3.4. Conduit

Furnish: Conduit; conduit fittings; bushings (grounding where required); LB condulets (as required); weatherheads (as required); conduit straps; hardware; conduit sealant.

Conduit that may be subject to regular pressure from traffic shall be laid to a minimum depth of 24 inches below grade. Conduit that will not be subject to regular pressure from traffic shall be laid to a minimum depth of 18 inches below grade.

Conduit ends shall be reamed to remove burrs and sharp edges. Cuts shall be square and true so that the ends will butt together for the full circumference of the conduit. Tighten couplings until the ends of the conduit are brought together. Do not leave exposed threads. Damaged portions of the galvanized surfaces and untreated threads resulting from field cuts shall be painted with an Engineer-approved, rust inhibitive paint. Conduit bends shall have a radius of no less than 12 times the nominal diameter of the conduit, unless otherwise shown on the plans.

Contractor shall install a bushing (grounding bushing where required) on both ends of all conduits. Cap spare conduits on both ends with caps or conduit sealant.

Conduit openings in junction boxes and cabinets shall be waterproofed with a flexible, removable conduit sealant, working it around the wires, and extending it a minimum 1 inch into the end of the conduit.

After the conduit has been installed and prior to backfilling, the conduit installation shall be inspected and approved by the Engineer.

3.5. Electrical Service

Furnish: Meter base, service disconnect, wire, GFCI AC duplex receptacle with box and cover; conduit, conduit fittings, bushings (grounding where required); LB condulets (as required); weatherhead; conduit straps; hardware; conduit sealant; ground rod with clamp; grounding conductor.

Prior to any construction, the Contractor shall initiate a work order with the local power

company for the installation of electrical service to the site. A representative from the Division of Planning and the local power company shall be consulted prior to choosing an exact location for the pole. The Contractor shall clear the right-of-way for the electrical service drop.

Contractor shall obtain electrical inspections, memberships, meter base, service disconnect and any other requirements by the utility serving the installation and pay all fees as required.

Install meter-base and disconnect panel with a 30-ampere, fused, circuit breaker inside. Install a manufactured weatherproof hub connectors to connect the conduit to the top of the meter base and service disconnect.

Install a rigid $\frac{3}{4}$ inch conduit with three 8 AWG service conductors from the cabinet, through the service disconnect to the meter base and a $1\frac{1}{4}$ " conduit with three 8 AWG service conductors from the meter base to a weatherhead two feet from the top of the electrical service pole. Install conduit straps 30 inches on center and provide a drip loop where the wire enters the weatherhead. Splice electric drop with service entrance conductors at the top of the pole.

The limit of conduit incidental to "Install Electrical Service" for a pad mounted cabinet is 24 inches beyond face of service pole.

Install a 120-volt, 20-amp GFCI AC duplex receptacle with box and cover in the automatic data recorder (ADR) cabinet.

Install a ground rod with clamp. Install a grounding conductor wire from the meter base, through the disconnect panel, to the ground rod clamp. Install grounding conductor in $1\frac{3}{4}$ " conduit from service disconnect to ground rod.

After completing the installation and before the electrical service is connected, obtain a certificate of compliance from the Kentucky Department of Housing, Buildings and Construction, Electrical Inspection Division.

3.6. Flashing Arrow

Furnish: Arrow Panel

Construction of Flashing Arrow shall conform to the *Standard Specifications for Road and Bridge Construction*.

3.7. Galvanized Steel Cabinet

Furnish: Cabinet; wood posts; concrete; conduit fittings; metal framing channel; pipe clamp; terminal block(s); spade tongue wire terminals; wire labels; hardware.

Where right-of-way allows, locate the cabinet such that it is outside the clear zone in accordance with the *Roadside Design Guide*. Install Cabinet such that the door of the

cabinet faces the roadway.

Excavate as required and install wood posts to a depth of 36 inches and place concrete around posts as shown on the standard detail sheets. Install metal framing channel with pipe clamp between posts.

Install Cabinet on wood posts 38 inches above the finished grade as shown on the standard detail sheets. Install a unistrut between posts when two posts are specified.

Install the required number of terminal blocks on the cabinet back plate. Install a spade tongue terminal on each loop and piezo sensor wire entering the cabinet and connect wires to terminal block(s). Wiring shall be neat and orderly. Label all wires and cables inside cabinet.

Install conduit from ground to cabinet and attach to pipe clamp. Install locknuts to attach conduit to cabinet and install a conduit bushing as shown on the standard detail sheets.

3.8. Grounding

Furnish: Ground rod with clamp; grounding conductor.

At sites with electrical or solar service, all conduits, poles, and cabinets shall be bonded to ground rods and the electrical system ground to form a complete grounded system.

Install such that top of ground rod is a minimum of 3 inches below finished grade.

Grounding systems shall have a maximum 25 ohms resistance to ground. If the resistance to ground is greater than 25 ohms, two or more ground rods connected in parallel shall be installed. Adjacent ground rods shall be separated by a minimum of 6 feet.

3.9. Install Pad Mount Enclosure

Furnish: Concrete; anchor bolts with washers and nuts; conduit; conduit fittings; conduit grounding bushings; ground rod with clamp; grounding conductor; conduit sealant; wooden stakes (where required); wire labels; hardware.

The Contractor shall be responsible for securing the enclosure from the Central Office Division of Planning Warehouse in Frankfort and transporting it to the installation site.

Where right-of-way allows, locate the enclosure such that it is outside the clear zone in accordance with the *Roadside Design Guide*.

Excavate as required, and place concrete to construct the enclosure foundation as specified on the standard detail sheets. Install enclosure on the concrete base such that the door(s) of the enclosure opens away from traffic (hinges away from traffic). Install anchor bolts, washers, and nuts to secure the enclosure to the foundation.

Install ground rod with clamp and install one $\frac{3}{4}$ inch rigid conduit from enclosure base to

ground rod. Install a grounding conductor from ground rod to enclosure base and bond to each conduit bushing in the base.

Install one ¾ inch rigid steel conduit for electrical service from the base of the enclosure to 24 inches beyond the concrete base. Make all field wiring connections to the electrical service, as applicable.

If electrical service is not provided as a bid item in the contract, plug conduit on both ends with a cap, conduit sealant, or electrical tape. Mark the location of the buried conduit end with a wooden stake labeled “¾ in. conduit.”

Install specified rigid steel conduit(s) into the base of the enclosure for sensor wire entry. Install one spare 2 inch conduit from the enclosure base to 2 feet beyond the concrete base. Plug spare conduit on both ends with a cap, conduit sealant or electrical tape.

The limit of all conduits incidental to “Install Pad Mount Enclosure” is 24 inches beyond the edge of the concrete base.

Wiring in enclosure shall be neat and orderly. Label all wires and cables inside enclosure. KYTC personnel will furnish and install terminal blocks and connect sensors to terminal blocks.

3.10. Install Controller Cabinet

Furnish: Mounting brackets; mounting straps; conduit; LB condulets; conduit fittings; conduit grounding bushings; ground rod with clamp; grounding conductor; cable staples; conduit sealant; wooden stakes (where required); wire labels; hardware.

The Contractor shall be responsible for securing the cabinet from the Central Office Division of Planning Warehouse in Frankfort and transporting it to the installation site. Any existing holes in the cabinet not to be reused shall be covered or plugged to meet NEC requirements.

Install mounting brackets and secure cabinet to pole with mounting straps.

Install a ground rod with clamp. Install grounding conductor in 1-¾” conduit from cabinet to ground rod.

Install one ¾ inch rigid steel conduit with two lb condulets from cabinet to electrical service disconnect box. Make all field wiring connections to the electrical service, as applicable.

If electrical service is not provided as a bid item in the contract, plug conduit on both ends with cap, plumbers putty, conduit sealant, or electrical tape. Mark the location of the buried conduit end with a wooden stake labeled “¾ in. conduit”.

Install specified rigid steel conduit(s) and type LB condulet(s) into the bottom of the

cabinet for sensor wire entry. The limit of conduits incidental to “Install Controller Cabinet” is 24 inches beyond the face of the pole.

Wiring in cabinet shall be neat and orderly. Label all wires and cables inside cabinet. KYTC personnel will furnish and install terminal blocks and connect sensors to terminal blocks.

3.11. Junction Box Type 10x8x4

Furnish: Junction box; wood post; conduit fittings; wire labels; hardware.

Where right-of-way allows, locate the junction box such that it is outside the clear zone in accordance with the Roadside Design Guide.

Excavate as required and install wood post(s) to a depth of 18 inches. Install junction box on wood post such that the bottom of the box is 18 inches above the finished grade as shown on the standard detail sheets. Box shall be installed with four (4) 2½ inch wood screws and washers.

Install locknuts to attach conduit to junction box and install a conduit bushing as shown on the standard detail sheets.

Wiring inside box shall be neat and orderly. Label all wires and cables inside box.

3.12. Junction Box Type A, B, or C

Furnish: Junction box, No. 57 aggregate; grounding conductor

Excavate as required and place approximately 12 inches of No. 57 aggregate beneath the proposed junction box to allow for drainage. Install specified junction box type A, B, or C near the edge of pavement, flush with finished grade per the detail sheets. Where required, orient the box so that the dimensions comply with the National Electrical Code. Stub conduits with grounding bushings into junction box at its base to accommodate wires and connect grounding conductor to all grounding bushings. Backfill to existing grade, and restore disturbed area to the satisfaction of the Engineer.

Wiring inside box shall be neat and orderly. Label all wires and cables inside box.

3.13. Loops - Proposed

Furnish: Wire; saw slot sealant; backer rod; grout; conduit sealant.

The plans and notes specify the approximate location for loop installations. Prior to sawing slots or drilling cores, the Contractor shall meet with a representative of the Division of Planning to verify the precise layout locations on site. Avoid expansion joints and pavement sections where potholes, cracks, or other roadway flaws exist.

Upon completion of this meeting, the Contractor shall measure out and mark the proposed loop locations with spray paint or chalk such that the saw slots will be parallel

and perpendicular to the direction of traffic. Marked lines shall be straight and exact to the locations determined and sized as shown on the plans. Unless indicated otherwise, loops shall be 6 feet by 6 feet square and loops in the same lane shall be spaced 16 feet from leading edge to leading edge.

On resurfacing, rehabilitation, and new construction projects that include new asphalt pavement, the Contractor shall install loops prior to laying the final surface course. On projects with milling and texturing, the Contractor may install the loops prior to or after the milling operation; however, if installed prior to milling, the Contractor shall be responsible for ensuring that the loops are installed at a depth such that the milling operation will not disturb the newly installed loops. The Contractor shall correct damage caused by the milling operations to newly installed loops prior to placement of the final surface course at no additional cost to the Cabinet.

For projects that include the installation of new asphalt and piezoelectric sensors, the Contractor shall mark or otherwise reference all loops installed prior to the final surface course such that the loops can be accurately located when the piezoelectric sensors are installed after placement of the final surface course.

For projects that do not have asphalt surfacing, the Contractor shall install the loops in the surface of the pavement.

The Prime Contractor shall coordinate the installation of loops with the electrical sub-Contractor and the Engineer to ensure correct operation of the completed installation.

The following is a typical step by step procedure for the installation of a loop.

- Carefully mark the slot to be cut, perpendicular to the flow of traffic and centered in the lane.
- Make each saw-cut 3/8-inch wide and at a depth such that the top of the backer rod is a minimum of 2 inches below the surface of rigid (PCC/Concrete) pavement or 4 inches below the surface of asphalt pavement.
- Drill a 1½ inch core hole at each corner and use a chisel to smooth corners to prevent sharp bends in the wire.
- Clean ALL foreign and loose matter out of the slots and drilled cores and within 1 foot on all sides of the slots using a high pressure washer.
- Completely dry the slots and drilled cores and within 1 foot on all sides of the slots using oil-free forced air, torpedo heaters, electric heaters, or natural evaporation, depending on weather conditions. Be very careful not to burn the asphalt if heat is used.
- Measure 9-12 inches from the edge of the paved surface (shoulder break or face of curb) and drill a 1½ inch hole on a 45° angle to the conduit adjacent to the roadway.
- Closely inspect all cuts, cores, and slots for jagged edges or protrusions prior to the placement of the wire. All jagged edges and protrusions shall be ground or re-cut and cleaned again.

- Place the loop wire splice-free from the termination point (cabinet or junction box) to the loop, continue around the loop for four turns, and return to the termination point.
- Push the wire into the saw slot with a blunt object such as a wooden stick. Make sure that the loop wire is pushed fully to the bottom of the saw slot.
- Install conduit sealant to a minimum of 1" deep into the cored 1½ inch hole.
- Apply loop sealant from the bottom up and fully encapsulate the loop wires in the saw slot. The wire should not be able to move when the sealant has set.
- Cover the encapsulated loop wire with a continuous layer of backer rod along the entire loop and home run saw slots such that no voids are present between the loop sealant and backer rod.
- Finish filling the saw cut with non-shrinkable grout per manufacturer's instructions. Alleviate all air pockets and refill low spaces. There shall be no concave portion to the grout in the saw slot. Any excess grout shall be cleaned from the roadway to alleviate tracking.
- Clean up the site and dispose of all waste off the project.
- Ensure that the grout has completely cured prior to subjecting the loop to traffic. Curing time varies with temperature and humidity.

Exceptions to installing loop wire splice-free to the junction box or cabinet may be considered on a case-by-case basis and must be pre-approved by the Engineer. If splices are allowed, they shall be located in a junction box and shall conform to the construction note for Splicing.

If loop lead-in cable (Cable No. 14/1 Pair) is specified, cable shall be installed splice free to the cabinet ensuring that extra cable is left in each junction box or cabinet. All wires and cables shall be labeled in each junction box and cabinet.

Loop inductance readings shall be between 100 and 300 microhenries. The difference of the loop inductance between two loops in the same lane shall be ± 20 microhenries. Inductance loop conductors shall test free of shorts and grounds. Upon completion of the project, all loops must pass an insulation resistance test of a minimum of 100 million ohms to ground when tested with a 500 Volt direct current potential in a reasonably dry atmosphere between conductors and ground.

3.14. Loops – Existing

When noted on a data collection station layout sheet that there are existing inductive loops within the limits of the project, notify the Engineer in writing, a minimum of 14 calendar days prior to beginning milling operations. After milling and prior to placing asphalt inlay, conduct an operating test on the existing inductance loops at the control cabinet in the presence of the Engineer to determine if the inductance loop conductors have an insulating resistance of a minimum of 100 megohms when tested with a 500 volt direct current potential in a reasonably dry atmosphere between conductors and ground. The Department may also conduct its own tests with its own equipment.

If the tests indicate the loop resistances are above the specified limit and the Engineer determines the system is operable, proceed with the asphalt inlay. If the test indicates the loop resistance is not within the specified limits or if the Engineer determines the system is otherwise not operable, prior to placing the asphalt inlay install and test new loop detectors according to the station layout, notes, and Detail Drawings.

The Engineer will contact and maintain liaison with the District Planning Engineer and the Division of Planning in order to coordinate any necessary work.

3.15. Maintain and Control Traffic

Furnish (all as required): Drums, traffic cones, barricades used for channelization purposes, delineators, and object markers.

Maintain and Control Traffic shall conform to the plans, the Standard Specifications for Road and Bridge Construction, and the KYTC Department of Highways Standard Drawings.

3.16. Open Cut Roadway

Furnish: Concrete, reinforcing bars.

Excavate trench by sawing and chipping away roadway to dimensions as indicated on the detail sheets. After placing conduit, install concrete and steel reinforcing bars per the *Standard Specifications for Road and Bridge Construction*. Restore any disturbed sidewalk to its original condition.

3.17. Piezoelectric Sensor

Furnish: Piezoelectric sensor and cable; sensor support brackets; saw slot sealant; backer rod; grout; conduit sealant.

The plans and notes specify the approximate location for piezoelectric sensor (piezo) installations. Prior to sawing slots or drilling cores, the Contractor shall meet with a representative of the Division of Planning to verify the final layout on site. Avoid expansion joints and pavement sections where potholes, cracks, or other roadway flaws exist. Roadway ruts at the proposed piezo location shall not be in excess of 1/2 inch under a 4-foot straight edge.

Install the piezo perpendicular to traffic in the final surface course of the pavement. Locate the sensor in the lane as shown on the site layout drawing. Eleven-foot length sensors shall be centered in the lane.

The following is a typical step by step procedure for the installation of a piezo. Refer specifically to the manufacturer's instructions provided with the sensor prior to installation.

- Carefully mark the slot to be cut, perpendicular to the flow of traffic and properly positioned in the lane.

- It is strongly recommended that a 3/4 inch wide diamond blade be used for cutting the slot, or that blades be ganged together to provide a single 3/4 inch wide cut. The slot shall be wet cut to minimize damage to the pavement.
- Cut a slot 3/4 inch wide ($\pm 1/16$ inch) by 1 inch minimum deep. The slot should be a minimum of 2 inches longer than the sensor (including the lead attachment). Drop the saw blade an extra 1/2 inch down on both ends of the sensor. The lead out of the passive cable should be centered on the slot.
- Cut the slot for the passive cable 1/4 inch wide and at a depth so that the top of the backer rod is a minimum of 2 inches below the road surface.
- Clean ALL foreign and loose matter out of the slot and within 1 foot on all sides of the slot using a high pressure washer.
- Completely dry the slot and within 1 foot on all sides of the slot using oil-free forced air, torpedo heaters, electric heaters, or natural evaporation, depending on weather conditions. Be very careful not to burn the asphalt if heat is used.
- Measure 9-12 inches from the edge of the paved surface (shoulder break or face of curb) and drill a 1 1/2 inch hole on a 45° angle to the conduit adjacent to the roadway.
- Place strips of 2-4 inch wide tape strips on the pavement along the lengths of both sides of the sensor slot, 1/8 inch away from the slot.
- Wear clean, protective latex (or equivalent) gloves at all times when handling sensors. Visually inspect sensor to ensure it is straight. Check lead attachment and passive cable for cuts, gaps, cracks and/or bare wire. Verify that the correct sensor type and length is being installed by checking the data sheet. Verify there is sufficient cable to reach the cabinet. Piezo lead-in cable shall not be spliced.
- Test the sensor for capacitance, dissipation factor and resistance, according to the directions enclosed with the sensor. Capacitance and dissipation should be within $\pm 20\%$ of the piezo data sheet. Resistance (using the 20M setting) should be infinite. Record the sensor serial number and the test results and label "pre-installation." This information should be stored in the counter cabinet and/or returned to Department Planning personnel.
- Lay the sensor next to the slot and ensure that it is straight and flat.
- Clean the sensor with steel wool or an emery pad and wipe with alcohol and a clean, lint-free cloth.
- Place the installation bracket clips every 6 inches along the length of the sensor.
- Bend the tip of the sensor downward at a 30° angle. Bend the lead attachment end down at a 15° angle and then 15° back up until level (forming a lazy Z).
- Place the sensor in the slot, with the brass element 3/8 inch below the road surface along the entire length. The tip of the sensor should be a minimum of 2 inches from the end of the slot and should not touch the bottom of the slot. The top of the plastic installation bracket clips should be 1/8 inch below the surface of the road. The lead attachment should not touch the bottom or sides of the slot. Ensure the sensor ends are pushed down per the manufacturer's instructions.
- Visually inspect the length of the sensor to ensure it is at uniform depth along its length and it is level (not twisted, canted or bent).

- On the passive cable end, block the end of the slot approximately 3-5 inches beyond the end of the lead attachment area creating an adequate “dam” so that the sensor grout does not flow out.
- Use one bucket of sensor grout per piezo installation. Overfill the slot with sensor grout and allow to cure for a minimum of 10 minutes before continuing with the installation. Ensure that sensor grout fills around and beneath the sensor completely and that there is not a trough on top.
- Remove the tape along the sides of the saw slot when the adhesive starts to cure.
- Carefully remove the dam from the end of the sensor.
- Route the lead-in cable through the saw slot
- Install conduit sealant to a minimum of 1” deep into the cored 1½ inch hole.
- Cover the lead-in cable with encapsulant, backer rod, and grout.
- If necessary, after the grout has hardened, grind with an angle grinder until the profile is a 1/16 inch mound. There shall be no concave portion to the mound.
- Clean up the site and dispose of all waste off the project.
- Ensure that the sensor grout has completely cured prior to subjecting the sensor to traffic. Curing time will vary with temperature and humidity.

Upon installation, test the sensor for capacitance, dissipation factor and resistance, according to the directions enclosed with the sensor. Capacitance and dissipation should be within $\pm 20\%$ of the piezo data sheet. Resistance (using the 20M setting) should be infinite. Perform a functional test of the piezo with an oscilloscope to ensure that the sensor is generating a proper response to the passage of vehicles.

Record the sensor serial number and the test results and label “post-installation.” This information should be stored in the counter cabinet and/or returned to Department Planning personnel.

3.18. Pole – Wooden

Furnish: Pole; anchoring equipment (as required); hardware (as required).

Excavate and install wood pole to a minimum depth of one-sixth the total pole height. Place backfill material in hole and compact until flush with existing grade. Install guy wire, guy guard, anchor, anchor rod, and strand vise, if necessary. Anchor shall be a minimum of one-third the pole height from the face of the pole. Provide temporary erosion control, seeding, protection and restoration of disturbed areas to the satisfaction of the Engineer.

3.19. Removal of Existing Equipment

The Contractor shall remove existing materials (including but not limited to: poles, anchors, cabinets, junction boxes, conduit and wire) not to be reused. Contractor shall dispose of all removed materials off the project. All materials and labor necessary for the removal of existing equipment shall be considered incidental to other bid items.

3.20. Signs

Furnish: Signs; sign standards; hardware.

Construction of signs shall conform to the *Standard Specifications for Road and Bridge Construction*.

3.21. Splicing

Furnish: Splice kit; solder.

These notes describe the splicing process (if permitted) and are not intended to grant permission to splice. Permission to splice shall be determined by the Division of Planning and the locations shall be shown on the layout sheet. If splicing is needed but not shown on the layout sheet, the Contractor shall receive prior written approval from the Division of Planning.

All splices shall conform to the provisions of the NEC.

Splices for loop and loop lead-in wire shall be twisted and soldered. Abrade the outer jacket of both wires to promote good adhesion and prevent capillary leak paths. Seal the splice with an electrical sealing resin. Spliced loop conductors shall test free of shorts and unauthorized grounds and shall have an insulating resistance of at least 100 megohms when tested with a 500 volt direct current potential in a reasonably dry atmosphere between conductors and ground.

For piezos, the same type coax cable, supplied by the manufacturer, shall be used to splice to the sensor's lead-in cable. Cables shall be soldered. Abrade the outer jacket of both cables to promote good adhesion and prevent capillary leak paths. Seal the splice with an electrical sealing resin. Spliced piezo cables shall be tested and have a minimum resistance of 20 megohms, a maximum dissipation factor of 0.03, a capacitance within the manufacturer's recommended range based upon the length of additional cable. A functional test of the piezo shall be performed to ensure that the sensor is generating a proper response to the passage of vehicles.

3.22. Trenching and Backfilling

Furnish: Warning tape; seed mix type I; cereal rye or German foxtail-millet; mulch; concrete (as required); asphalt (as required).

Excavate trench and provide required cover as shown on the standard detail sheets. After placing conduit, backfill material shall be placed and compacted in lifts of 9 inches or less. Install warning tape as shown on the detail sheet. Provide temporary erosion control, seeding, protection and restoration of disturbed areas to the satisfaction of the Engineer. This item shall include concrete, asphalt or approved replacement material for sidewalks, curbs, roadways, etc. (if required).

3.23. Wiring

Furnish: Wire; wire labels; spade tongue wire terminals (as required).

Installation of all wiring shall conform to the NEC. Permanent identification numbers shall be affixed to all wires in all junction boxes and cabinets (see Layout(s) for loop and piezo numbers).

Additional lengths of each loop and piezo sensor wire shall be neatly coiled in all cabinets and junction boxes as follows:

<u>Enclosure Type</u>	<u>Additional length of each wire</u>
Galvanized Steel Cabinet	2' - 3'
Pad Mount Cabinet (332)	6' - 8'
Pole Mount Cabinet (336)	3' - 4'
Junction Box Type 10x8x4	2' - 3'
Junction Box Type A, B, or C	2' - 3'

3.24. Wood Post

Furnish: Wood post; concrete (as required); seed mix type I; cereal rye or German foxtail-millet; mulch.

Excavate hole to specified depth and place concrete, if required. Install post, backfill to existing grade, and tamp backfill. Provide temporary erosion control, seeding, protection and restoration of disturbed areas to the satisfaction of the Engineer.

4. BID ITEM NOTES AND METHOD OF MEASUREMENT FOR PAYMENT

Only the bid items listed will be measured for payment. All other items required to complete the vehicle detection installation shall be incidental to other items of work. Payment at the contract unit price shall be full compensation for all materials, labor, equipment and incidentals to furnish and install these items.

4.1. Bore and Jack Pipe – 2”

Bore and jack pipe – 2” shall be furnished, installed, and measured for payment per the *Standard Specifications for Road and Bridge Construction*.

4.2. Conduit

Conduit shall include furnishing and installing specified conduit in accordance with the specifications. This item shall include conduit fittings, bodies, boxes, weatherheads, expansion joints, couplings, caps, conduit sealant, electrical tape, clamps, bonding straps and any other necessary hardware. Conduit will be measured in linear feet.

4.3. Electrical Service

Electrical Service shall include furnishing and installing all necessary materials and payment of all fees toward the complete installation of an electrical service which has passed all required inspections. Incidental to this item shall be furnishing and installing:

- Meter-base per utility company’s specifications
- Service disconnect panel per utility company’s specifications
- Meter base and service disconnect entrance hubs, waterproof
- Service entrance conductors
- Rigid steel conduit
- Rigid steel conduit fittings
- Conduit straps
- Weatherhead
- Duplex GFCI receptacle, 120-volt, 20-amp
- Ground rod with clamp
- Grounding conductor

Also incidental to this item shall be any necessary clearing of right of way for the electrical service drop.

Electrical service will be measured in individual units each.

4.4. Flashing Arrow

Flashing Arrow shall be furnished, installed, and measured for payment per the *Standard Specifications for Road and Bridge Construction*.

4.5. Galvanized Steel Cabinet

Galvanized Steel Cabinet shall include furnishing and installing galvanized steel cabinet on post as specified. Incidental to this item shall be furnishing and installing grounding hardware, and any necessary post/pole mounting hardware. Also incidental to this item shall be furnishing and installing the required number of terminal blocks and connection of all

sensors to the terminal blocks. Galvanized Steel Cabinet will be measured in individual units each.

4.6. Install Pad Mount Enclosure

Install Pad Mount Enclosure shall include installing a Department-furnished enclosure as specified on the detail sheets.

This item shall include obtaining the enclosure from KYTC and transporting it to the installation site and furnishing and installing the following:

- Concrete foundation (including any excavation necessary)
- Anchor bolts, lock washers, and nuts
- Conduit
- Conduit fittings (including grounding bushings)
- Weatherhead
- Terminal Strip(s)
- Ground rod with clamp
- Grounding conductor

Install Pad Mount Enclosure will be measured in individual units each.

4.7. Install Controller Cabinet

Install Controller Cabinet shall include installing a Department-furnished cabinet as specified on the detail sheets.

This item shall include obtaining the cabinet from KYTC and transporting it to the installation site and furnishing and installing the following:

- Conduit
- Conduit Fittings
- Terminal Strip(s)
- Ground rod with clamp
- Grounding conductor

Install Controller Cabinet will be measured in individual units each.

4.8. Junction Box Type 10" x 8" x 4"

Junction Box Type 10"x8"x4" shall include furnishing and installing specified junction box in accordance with the specifications. This item shall include connectors, splice sleeves, conduit fittings, mounting materials and any other items required to complete the installation. Incidental to this item shall be furnishing and installing specified post (wood, channel, metal, etc.) as required for the installation. Junction Box Type 10"x8"x4" will be measured in individual units each.

4.9. Junction Box Type A, B, or C

Junction Box Type A, B, or C shall include furnishing and installing specified junction box in accordance with the specifications. This item shall include excavation, furnishing and installing #57 aggregate, backfilling around the box, and restoration of disturbed areas to the satisfaction of the Engineer. Incidental to this item shall be furnishing and installing a

grounding conductor bonding all conduit grounding bushings in the box. Junction Box Type A, B, or C will be measured in individual units each.

4.10. Loop Saw Slot and Fill

Loop Saw Slot and Fill shall include sawing and cleaning saw slots and furnishing and installing conduit sealant, loop sealant, backer rod, grout, or other specified material. Loop Saw Slot and Fill will be measured in linear feet of sawed slot.

4.11. Maintain and Control Traffic

Maintain and Control Traffic shall be measured for payment per the *Standard Specifications for Road and Bridge Construction*.

4.12. Open Cut Roadway

Open Cut Roadway shall include excavating trench (sawing and chipping roadway) to dimensions as indicated on the detail sheets and furnishing and placing concrete, steel reinforcing bars, and asphalt. This item also includes restoring any disturbed sidewalk to its original condition. Open Cut Roadway will be measured in linear feet.

4.13. Piezoelectric Sensor

Piezoelectric sensor (piezo) shall include sawing and cleaning saw slots and furnishing and installing piezo in accordance with the specifications. This item shall include furnishing and installing lead-in wire, conduit sealant, encapsulation material, backer rod, grout, testing, and accessories. Piezo will be measured in individual units each.

4.14. Pole – 35' Wooden

Pole – 35' Wooden shall include excavation, furnishing and installing specified wood pole, backfilling and restoring disturbed areas to the satisfaction of the Engineer. Incidental to this item shall be furnishing and installing guy wire, anchor and anchor rod, strand vise, and guy guard, if specified.

Pole – 35' Wooden will be measured in individual units each.

4.15. Signs

Signs shall be furnished, installed, and measured for payment per the *Standard Specifications for Road and Bridge Construction*.

4.16. Trenching and Backfilling

Trenching and Backfilling shall include excavation, warning tape, backfilling, temporary erosion control, seeding, protection and restoration of disturbed areas to original condition. This item shall include concrete, asphalt or approved replacement material for sidewalks, curbs, roadways, etc. (if required). Trenching and backfilling will be measured in linear feet.

4.17. Wire or Cable

Wire or cable shall include furnishing and installing specified wire or cable within saw slot, conduit, junction box, cabinet, or overhead as indicated on the detail sheets. Incidental to this item shall be the labeling of all wires and cables in each junction box, cabinet and splice

box, and furnishing and installing other hardware required for installing cable. Wire or Cable will be measured in linear feet.

4.18. Wood Post

Wood Post shall include furnishing and installing wood post as specified. This item shall include excavation, furnishing and placing concrete (if required), backfilling around the post, and restoration of disturbed areas to the satisfaction of the engineer. Wood Post will be measured in individual units each.

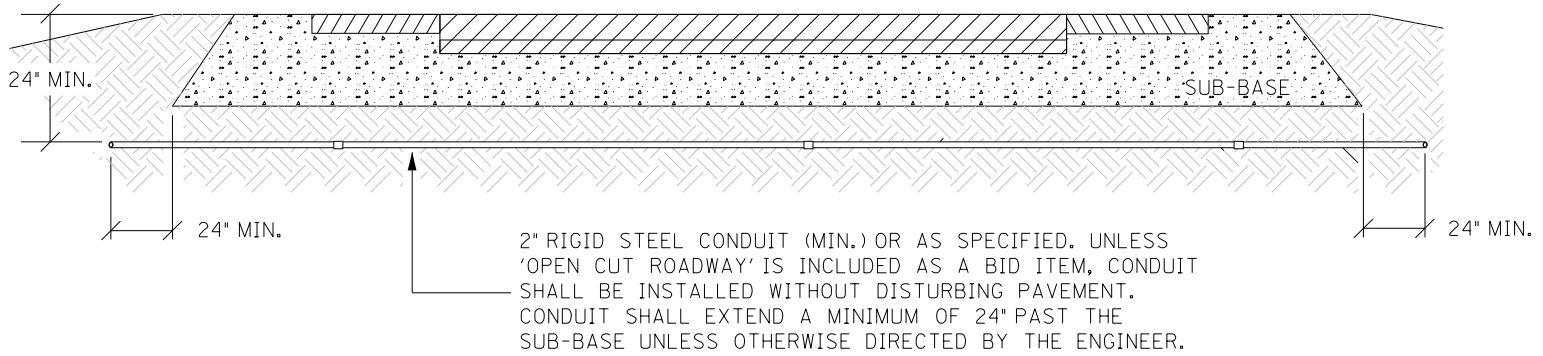

CONDUIT UNDER PAVEMENT

TOTAL TRENCH WIDTH SHALL BE 3" (NOM.) WIDER THAN THE SUM OF THE OUTSIDE DIAMETER(S) OF THE CONDUIT(S) INSTALLED. CONDUIT(S) SHALL BE CENTERED IN TRENCH.

CONTRACTOR SHALL PLACE BACKFILL IN LIFTS (9" MAX.) COMPACT BACKFILL, AND RESTORE DISTURBED AREA TO THE SATISFACTION OF THE ENGINEER

CONTRACTOR SHALL INSTALL UNDERGROUND UTILITY WARNING TAPE ABOVE CONDUIT AS SHOWN.

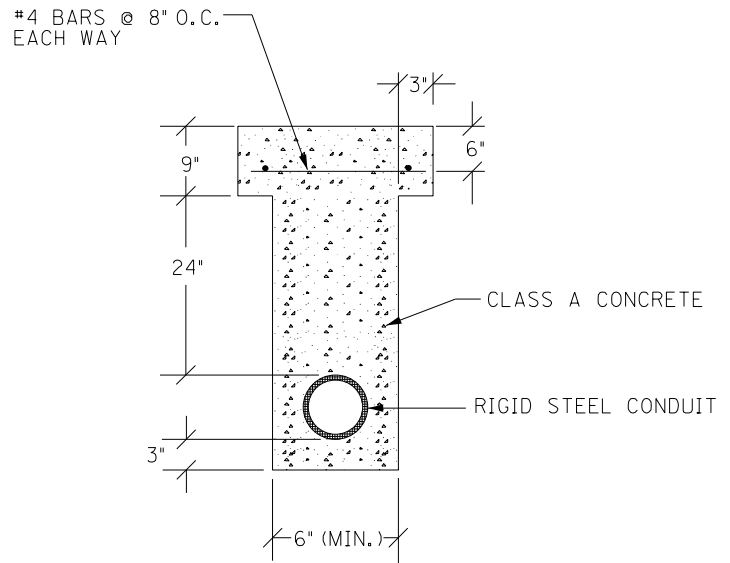
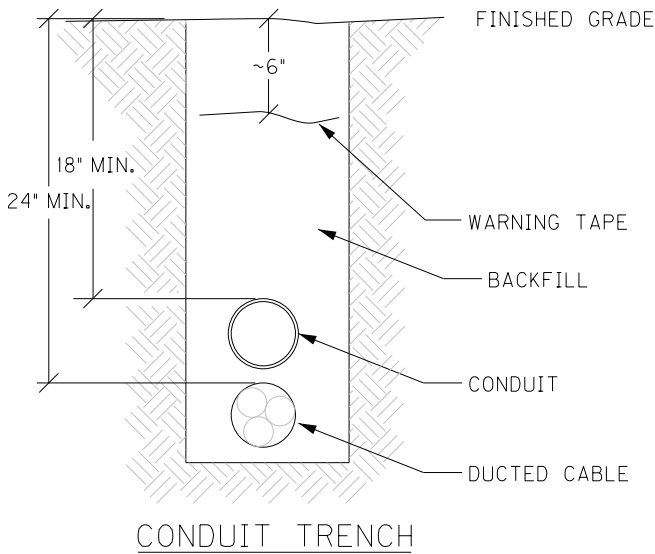

OPEN CUT PAVEMENT DETAIL

CONDUIT INSTALLATION

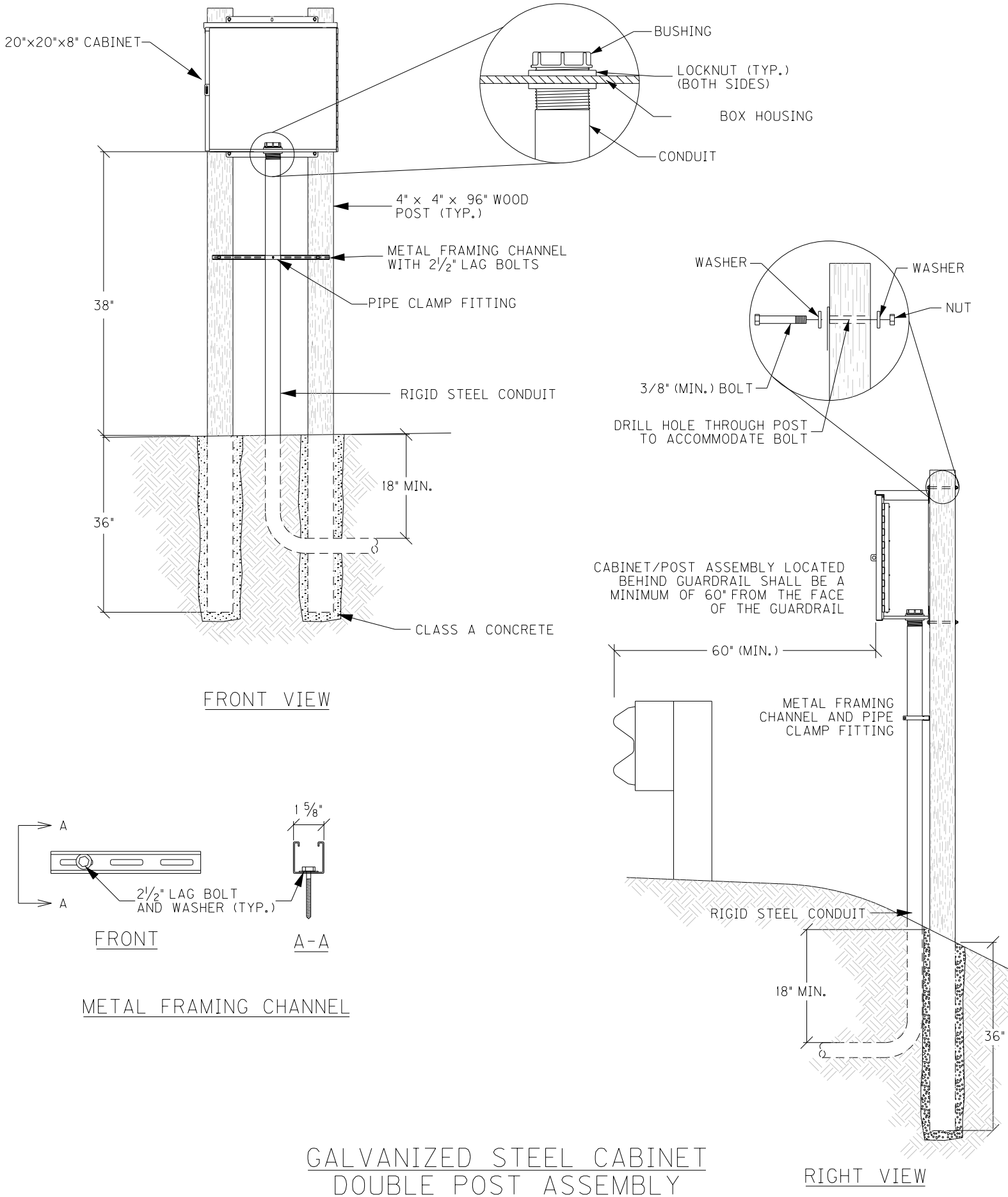

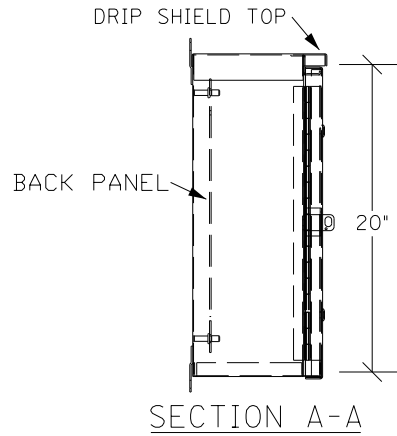
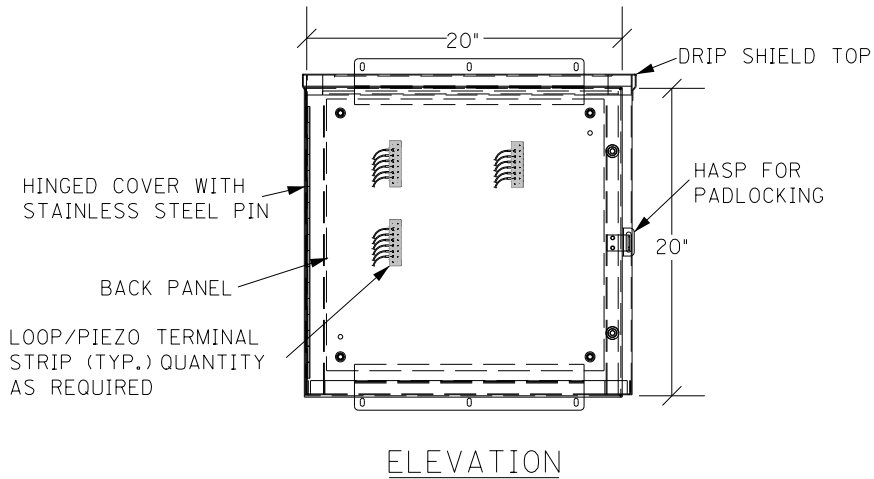
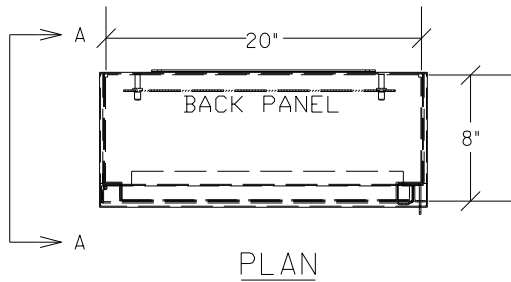

GALVANIZED STEEL CABINET

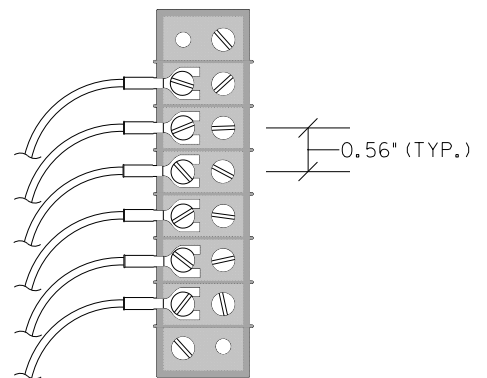
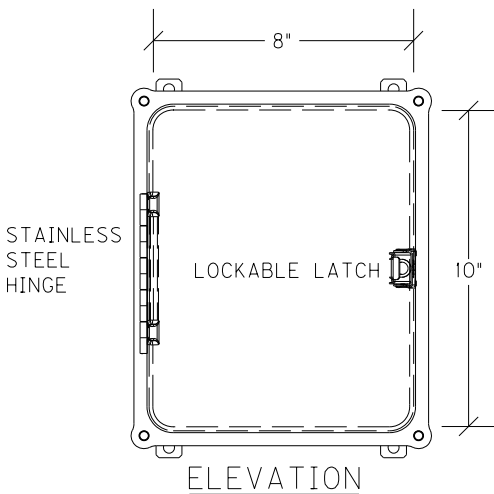
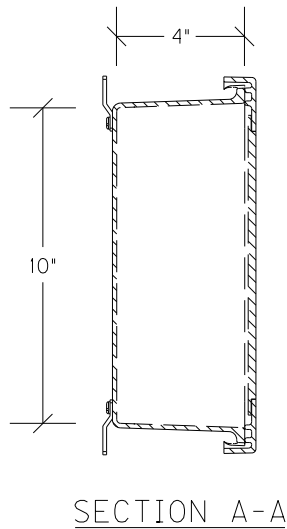
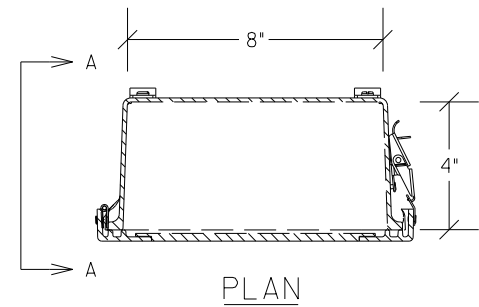

JUNCTION BOX 10"X8"X4"

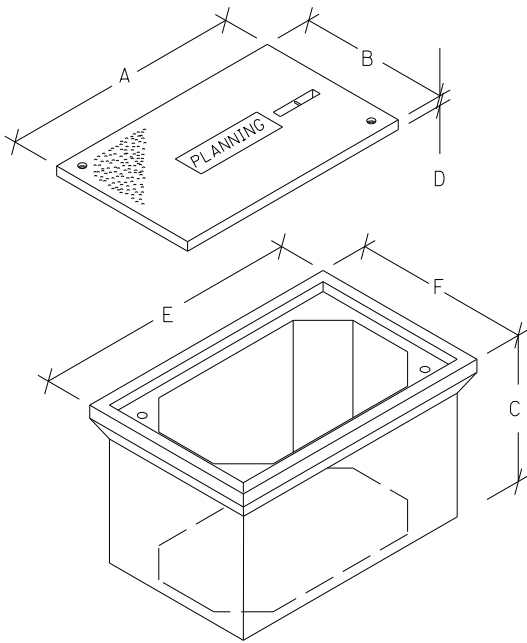

JUNCTION BOX DIMENSIONS (NOMINAL)						
	A	B	C	D*	E	F
TYPE A	23"	14"	18"	2"	25"	16"
TYPE B	18"	11"	12"	1¾"	20"	13"
TYPE C	36"	24"	30"	3"	38"	26"

* MINIMUM
STACKABLE BOXES ARE PERMITTED

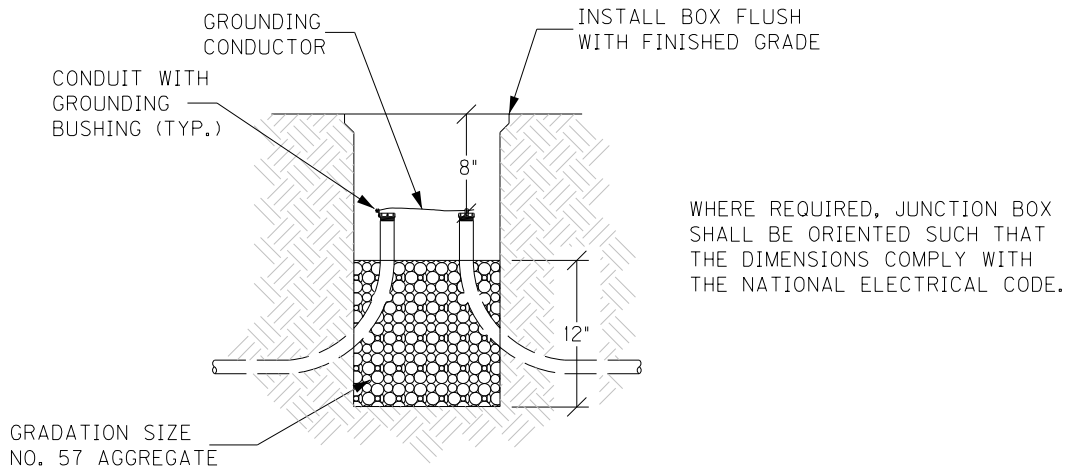

ELEVATION

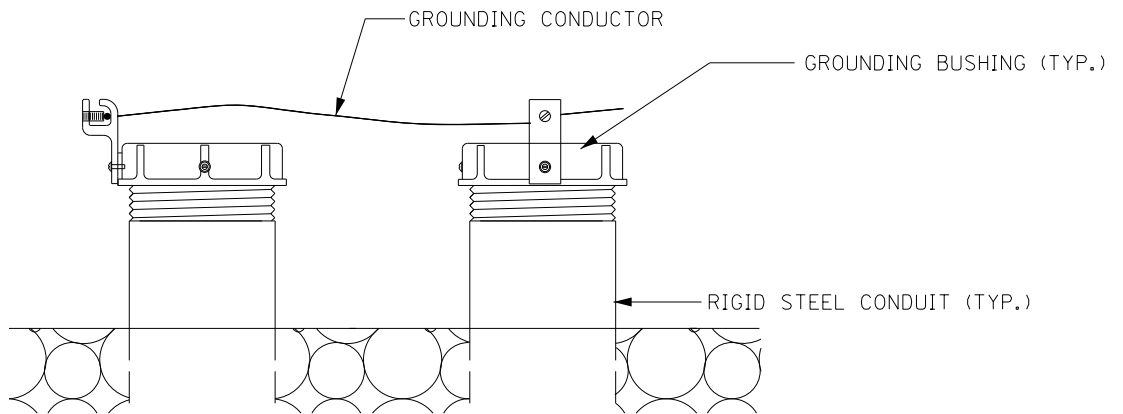

GROUNDING DETAIL

JUNCTION BOX - TYPE A, TYPE B, TYPE C

FAYETTE COUNTY
034GR21D049-N-PP

CUT BEYOND CORNER
TO REVEAL FULL DEPTH
CORE DRILL 1 1/2" HOLE AND/OR
CHISEL CORNER TO SLOT DEPTH
TO ELIMINATE SHARP EDGES

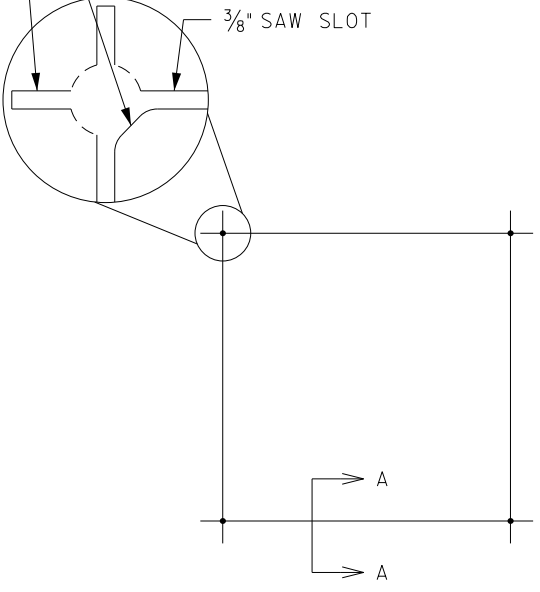

SAW CUT PLAN

UNLESS SPECIFIED OTHERWISE, ALL LOOPS SHALL BE 6' x 6' SQUARE, CENTERED IN EACH LANE, WITH FOUR TURNS OF 14 AWG LOOP WIRE.

ADJACENT SAW SLOTS SHALL BE A MINIMUM OF 12" APART.

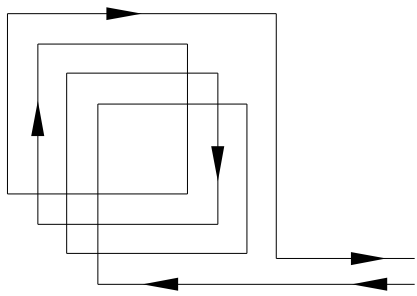

WIRING PLAN

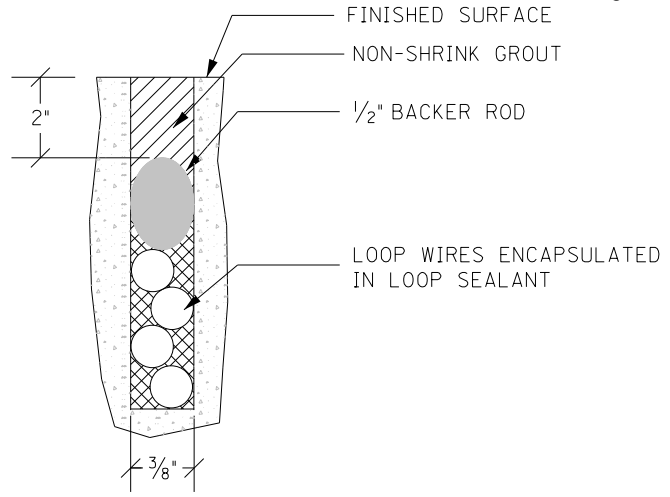

SECTION A-A (CONCRETE)

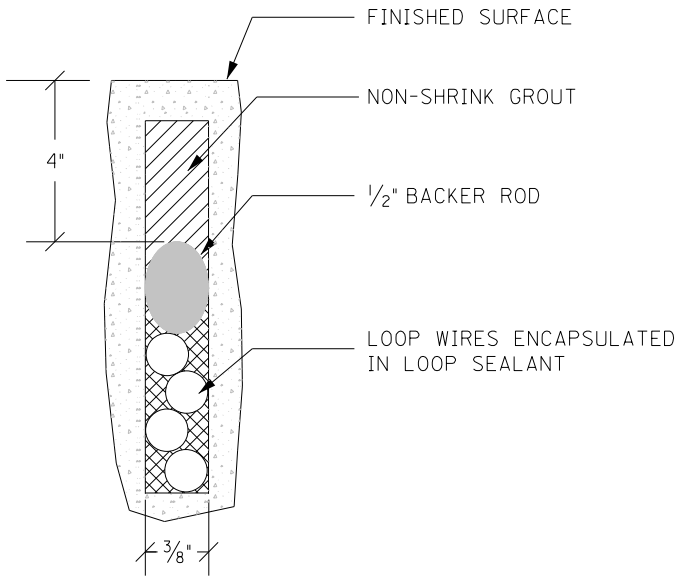

SECTION A-A (ASPHALT)

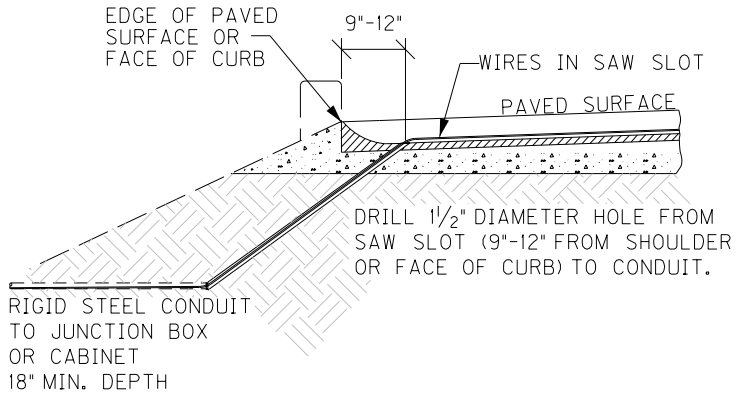

SAW SLOT EDGE OF PAVEMENT TRANSITION

INDUCTIVE LOOP DETECTOR

FAYETTE COUNTY
034GR211049-NHPP
SAW SLOT A
2" BEYOND
THE END OF THE SENSOR.

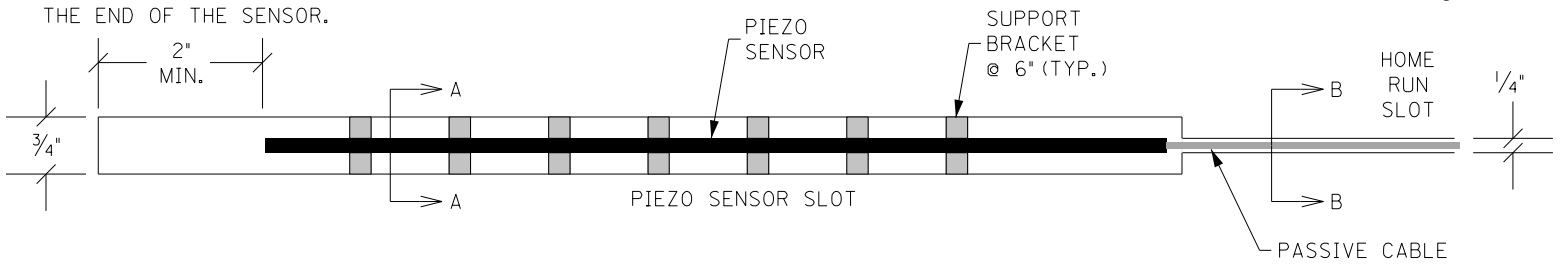

PLAN

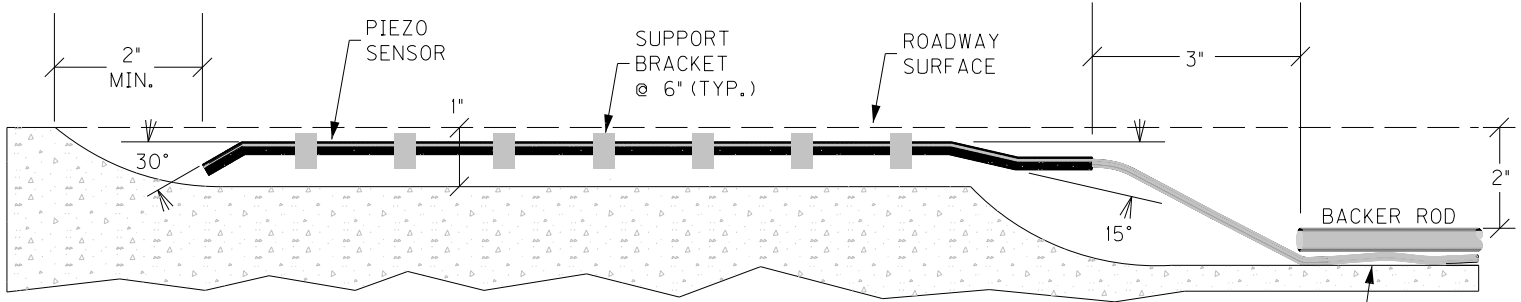

ELEVATION

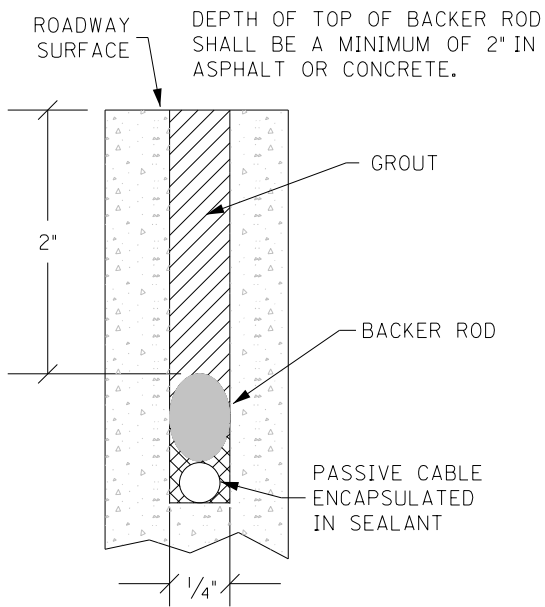

SECTION B-B

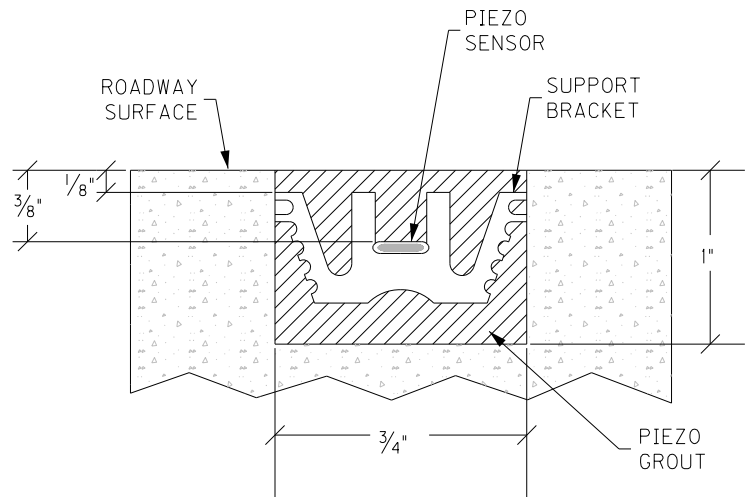

SECTION A-A

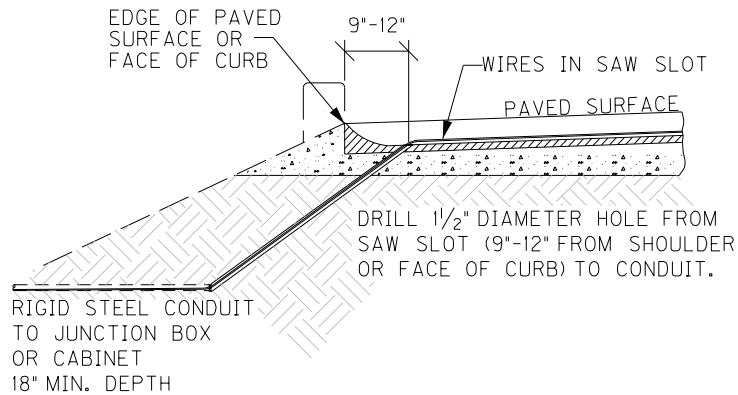

SAW SLOT EDGE OF PAVEMENT TRANSITION

PIEZOELECTRIC SENSOR INSTALLATION

July 19, 2019

SPECIAL NOTE FOR GEOCOMPOSITE REINFORCEMENT FOR ASPHALT

This Special Note will apply where indicated on the plans or in the proposal. Section references herein are to the Department’s 2019 Standard Specifications for Road and Bridge Construction.

1.0 DESCRIPTION. This specification covers geocomposites used as an interlayer in asphalt pavements.

2.0 MATERIALS AND EQUIPMENT.

2.1 Geocomposite. The geocomposite shall consist of a geogrid component with a non-woven geotextile (paving fabric) backing. Furnish fiberglass-reinforced or polyester geogrid coated with an elastomeric polymer. Ensure the geogrid forms a stable network such that the ribs, filaments, or yarns retain their dimensional stability, including selvages. Furnish geogrid with a non-woven paving fabric backing composed of long chain synthetic polymers that are 95 percent by weight polyolefins or polyesters.

A) Physical Requirements. Furnish the specified geogrid type conforming to the Physical Requirements Table and ASTM D 4759. Ensure that each geogrid shipment is accompanied by a manufacturer’s certification listing minimum average roll specification values (MARV) of each lot number for those properties listed in the table below. Furnish geogrid with a non-woven geotextile backing that conforms to AASHTO M288 Type II paving fabric with the exception of mass per unit area. Products that meet all Type II requirements except mass per unit area will be acceptable.

PROPERTY	TEST METHOD	SPECIFICATION
Geogrid Tensile Strength, lb/in (min.)	ASTM D6637 Test Method A	560
Geogrid Elongation, % (max.)	ASTM D6637	< 3
Melting Point of Paving Fabric Component, °F (min.)	ASTM D 276	320
Grid Size, inch (min/max)	Calipered	0.5/1.25

B) Packaging, Shipment, and Storage. Ensure that each roll is labeled with the manufacturer’s name, product type, style number, lot number, roll number, manufactured date, roll dimensions, chemical composition, and applicable physical properties. Protect the geocomposite from direct sunlight, ultraviolet rays, flames, aggressive chemicals, mud, dirt, dust, and debris during all periods of shipment and storage. Keep geocomposite dry until installation, and do not store directly on the ground.

July 19, 2019

2.2 Asphalt Distributor. Conform to 406.02.05.

2.3 Rolling Equipment. Use pneumatic-tired rollers that weigh at least 12 tons and have 7 to 9 tires capable of inflation pressures up to 125 psi. Maintain an inflation pressure in all tires within ± 5 psi of the manufacturer's recommended pressure. Arrange the tires so that the gap between the tires of the front axle is covered by the tires of the rear axle. Mount wheels to provide equal contact pressure under each wheel. Use a tire tread that is satisfactory to the Engineer. Maintain tire size and inflation pressure such that the contact pressure is at least 80 psi.

3.0 CONSTRUCTION.

3.1 Geocomposite Representative. Ensure that a representative of the geocomposite manufacturer is on the project when work begins, and remains on call as the project progresses, to advise the Engineer.

3.2 Weather Restrictions. Do not place the geocomposite when weather conditions, in the opinion of the Engineer, are not suitable. Ensure the air and pavement temperatures are sufficient to allow the tack coat to hold the geocomposite in place. Specifically, ensure the temperature is at least 50 °F and rising.

3.3 Surface Preparation. Perform any needed base repairs and repair all potholes, cracks greater than 1/4 inch, and any badly damaged or rough pavement, which may require milling or placement of leveling course. Ensure the surface is dry, clean, dust-free, and between 40 and 140 °F. Unless the geocomposite is precoated with an adhesive, apply tack according to the manufacturer's recommendations. This tack coat will not be measured for payment and will be considered incidental to the geocomposite. Distributor truck must be calibrated to supply the tack at the manufacturer's recommended rate before the job begins and this calibration is to be witnessed by the representative of the geocomposite manufacturer on the project. No work to install the geocomposite shall take place unless a representative from the geocomposite manufacture is on site.

3.4 Geocomposite Placement. Place the geocomposite while the tack coat is still tacky/broken. Keep the material flat and wrinkle free throughout the installation. Roll the geocomposite until the adhesive is activated or the geocomposite is seated in the tack coat. Clean the roller with an asphalt release agent. Brooming may be required. On sharp curves, cut the edges and fold the geocomposite over in the direction of the placement of the asphalt overlay. Overlap side joints by one to 2 inches. Overlap all end-of-roll joints by 3 to 6 inches. Ensure that the overlaps are shingled in the direction of paving.

3.5 Asphalt Placement. Place the asphalt overlay at a minimum 2-inch compacted thickness. Pave over the geocomposite on the same day of its placement. Except for paving equipment and vehicles, allow no traffic on the grid. Do not place tack coat on top of the interlayer grid.

3.6 Geocomposite Repair. Repair any visible distress that occurs due to movement of the geocomposite immediately after rolling. For small areas, remove the asphalt

July 19, 2019

mixture from the affected area; replace the geocomposite in its original position, and replace, level, and compact the asphalt mixture. Cut the geocomposite if necessary for it to lie flat.

3.7 Sampling and Testing. The Department will sample the geocomposite at the project site according to ASTM D 4354 and KM 64-113 at a frequency the Engineer determines. The Department will test the geocomposite for all properties possible given the testing equipment availability. When the Department determines that an individual sample fails to meet any specification requirement, the Department will reject that roll and sample two additional rolls from the same lot. When the Department determines that either of these two additional samples fails to comply with any part of the specification, the Department will reject the entire quantity of rolls represented by that sample.

4.0 MEASUREMENT. The Department will measure the quantity of geocomposite in square yards. The Department will not measure geocomposite when the contract indicates that the geocomposite are incidental to the work being performed or when no separate bid item for geocomposite is listed in the proposal. The Department will not measure providing the geocomposite manufacturer's representative for payment and will consider it incidental to the geocomposite. Tack coat, applied per the geocomposite manufacturer's recommendations, will not be paid and will be considered incidental to the geocomposite.

5.0 PAYMENT. The Department will make payment for the installed and accepted quantities under the following:

<u>Code</u>	<u>Pay Item</u>	<u>Pay Unit</u>
25010EC	Geocomposite Reinforcement for Asphalt	Square Yard



KENTUCKY TRANSPORTATION CABINET
Department of Highways
DIVISION OF RIGHT OF WAY & UTILITIES

TC 62-226
Rev. 01/2016
Page 1 of 1

RIGHT OF WAY CERTIFICATION

<input checked="" type="checkbox"/> Original	<input type="checkbox"/> Re-Certification	RIGHT OF WAY CERTIFICATION	
ITEM #	COUNTY	PROJECT # (STATE)	PROJECT # (FEDERAL)
7-20010.00	Fayette	FD52 034 0064 081-083	NHPP 0645 (081)
PROJECT DESCRIPTION			
ADDRESS PAVEMENT CONDITION OF PCC PAVEMENT ON I-064 BOTH DIRECTION(S) FROM MILEPOINT 81.037 TO MILEPOINT 82.19			
<input checked="" type="checkbox"/> No Additional Right of Way Required			
Construction will be within the limits of the existing right of way. The right of way was acquired in accordance to FHWA regulations under the Uniform Relocation Assistance and Real Property Acquisitions Policy Act of 1970, as amended. No additional right of way or relocation assistance were required for this project.			
<input type="checkbox"/> Condition # 1 (Additional Right of Way Required and Cleared)			
All necessary right of way, including control of access rights when applicable, have been acquired including legal and physical possession. Trial or appeal of cases may be pending in court but legal possession has been obtained. There may be some improvements remaining on the right-of-way, but all occupants have vacated the lands and improvements, and KYTC has physical possession and the rights to remove, salvage, or demolish all improvements and enter on all land. Just Compensation has been paid or deposited with the court. All relocations have been relocated to decent, safe, and sanitary housing or that KYTC has made available to displaced persons adequate replacement housing in accordance with the provisions of the current FHWA directive.			
<input type="checkbox"/> Condition # 2 (Additional Right of Way Required with Exception)			
The right of way has not been fully acquired, the right to occupy and to use all rights-of-way required for the proper execution of the project has been acquired. Some parcels may be pending in court and on other parcels full legal possession has not been obtained, but right of entry has been obtained, the occupants of all lands and improvements have vacated, and KYTC has physical possession and right to remove, salvage, or demolish all improvements. Just Compensation has been paid or deposited with the court for most parcels. Just Compensation for all pending parcels will be paid or deposited with the court prior to AWARD of construction contract			
<input type="checkbox"/> Condition # 3 (Additional Right of Way Required with Exception)			
The acquisition or right of occupancy and use of a few remaining parcels are not complete and/or some parcels still have occupants. All remaining occupants have had replacement housing made available to them in accordance with 49 CFR 24.204. KYTC is hereby requesting authorization to advertise this project for bids and to proceed with bid letting even though the necessary right of way will not be fully acquired, and/or some occupants will not be relocated, and/or the just compensation will not be paid or deposited with the court for some parcels until after bid letting. KYTC will fully meet all the requirements outlined in 23 CFR 635.309(c)(3) and 49 CFR 24.102(j) and will expedite completion of all acquisitions, relocations, and full payments after bid letting and prior to AWARD of the construction contract or force account construction.			
Total Number of Parcels on Project	0	EXCEPTION (S) Parcel #	ANTICIPATED DATE OF POSSESSION WITH EXPLANATION
Number of Parcels That Have Been Acquired			
Signed Deed	0		
Condemnation	0		
Signed ROE	0		
Notes/ Comments (Use Additional Sheet if necessary)			
LPA RW Project Manager		Right of Way Supervisor	
Printed Name		Printed Name	Cecil Smith
Signature		Signature	 Cecil Smith 2021.09.30 11:20:27 -04'00'
Date		Date	8/30/2021
Right of Way Director		FHWA	
Printed Name		Printed Name	No Signature Required as per FHWA-KYTC Current Stewardship Agreement
Signature	 2021.09.30	Signature	
Date	14:10:19 -04'00'	Date	



KENTUCKY TRANSPORTATION CABINET
Department of Highways
DIVISION OF RIGHT OF WAY & UTILITIES

TC 62-226
Rev. 01/2016
Page 1 of 1

RIGHT OF WAY CERTIFICATION

<input checked="" type="checkbox"/> Original	<input type="checkbox"/> Re-Certification	RIGHT OF WAY CERTIFICATION	
ITEM #	COUNTY	PROJECT # (STATE)	PROJECT # (FEDERAL)
7-20013.00	Fayette	FD52 034 0075 0107-112	NHPP 0645 (081)
PROJECT DESCRIPTION			
ADDRESS PAVEMENT CONDITION OF I-075 BOTH DIRECTION(S) FROM MILEPOINT 107.453 TO MILEPOINT 110.213			
<input checked="" type="checkbox"/> No Additional Right of Way Required			
Construction will be within the limits of the existing right of way. The right of way was acquired in accordance to FHWA regulations under the Uniform Relocation Assistance and Real Property Acquisitions Policy Act of 1970, as amended. No additional right of way or relocation assistance were required for this project.			
<input type="checkbox"/> Condition # 1 (Additional Right of Way Required and Cleared)			
All necessary right of way, including control of access rights when applicable, have been acquired including legal and physical possession. Trial or appeal of cases may be pending in court but legal possession has been obtained. There may be some improvements remaining on the right-of-way, but all occupants have vacated the lands and improvements, and KYTC has physical possession and the rights to remove, salvage, or demolish all improvements and enter on all land. Just Compensation has been paid or deposited with the court. All relocations have been relocated to decent, safe, and sanitary housing or that KYTC has made available to displaced persons adequate replacement housing in accordance with the provisions of the current FHWA directive.			
<input type="checkbox"/> Condition # 2 (Additional Right of Way Required with Exception)			
The right of way has not been fully acquired, the right to occupy and to use all rights-of-way required for the proper execution of the project has been acquired. Some parcels may be pending in court and on other parcels full legal possession has not been obtained, but right of entry has been obtained, the occupants of all lands and improvements have vacated, and KYTC has physical possession and right to remove, salvage, or demolish all improvements. Just Compensation has been paid or deposited with the court for most parcels. Just Compensation for all pending parcels will be paid or deposited with the court prior to AWARD of construction contract			
<input type="checkbox"/> Condition # 3 (Additional Right of Way Required with Exception)			
The acquisition or right of occupancy and use of a few remaining parcels are not complete and/or some parcels still have occupants. All remaining occupants have had replacement housing made available to them in accordance with 49 CFR 24.204. KYTC is hereby requesting authorization to advertise this project for bids and to proceed with bid letting even though the necessary right of way will not be fully acquired, and/or some occupants will not be relocated, and/or the just compensation will not be paid or deposited with the court for some parcels until after bid letting. KYTC will fully meet all the requirements outlined in 23 CFR 635.309(c)(3) and 49 CFR 24.102(j) and will expedite completion of all acquisitions, relocations, and full payments after bid letting and prior to AWARD of the construction contract or force account construction.			
Total Number of Parcels on Project	0	EXCEPTION (S) Parcel #	ANTICIPATED DATE OF POSSESSION WITH EXPLANATION
Number of Parcels That Have Been Acquired			
Signed Deed	0		
Condemnation	0		
Signed ROE	0		
Notes/ Comments (Use Additional Sheet if necessary)			
LPA RW Project Manager		Right of Way Supervisor	
Printed Name		Printed Name	Cecil Smith
Signature		Signature	Cecil Smith 2021.09.30 11:21:14 -04'00'
Date		Date	8/30/2021
Right of Way Director		FHWA No Signature Required as per FHWA-KYTC Current Stewardship Agreement	
Printed Name		Printed Name	
Signature	Charles Hale 2021.09.30 14:11:27 -04'00'	Signature	
Date		Date	

UTILITIES AND RAIL CERTIFICATION NOTE

<p style="text-align: center;">Fayette County 7-20010.00 NHPP 0645 (081) FD52 034 US-0064 081-083 Mile point: 81.037 TO 82.19 Address pavement condition of I-64 both directions</p>

PROJECT NOTES ON UTILITIES

Please Note: The information presented in this Utility Note is informational in nature and the information contained herein is not guaranteed.

The contractor will be responsible for contacting all utility facility owners on the subject project to coordinate his activities. The contractor will coordinate his activities to minimize and, where possible, avoid conflicts with utility facilities. Due to the nature of the work proposed, it is unlikely to conflict with the existing utilities beyond minor facility adjustments. Where conflicts with utility facilities are unavoidable, the contractor will coordinate any necessary relocation work with the facility owner and Resident Engineer. The Kentucky Transportation Cabinet maintains the right to remove or alter portions of this contract if a utility conflict occurs. The utility facilities as noted in the previous section(s) have been determined using data garnered by varied means and with varying degrees of accuracy: from the facility owners, a result of S.U.E., field inspections, and/or reviews of record drawings. The facilities defined may not be inclusive of all utilities in the project scope and are not Level A quality, unless specified as such. It is the contractor's responsibility to verify all utilities and their respective locations before excavating.

The contractor shall make every effort to protect underground facilities from damage as prescribed in the Underground Facility Damage Protection Act of 1994, Kentucky Revised Statute KRS 367.4901 to 367.4917. It is the contractor's responsibility to determine and take steps necessary to be in compliance with federal and state damage prevention directives. The contractor is instructed to contact KY 811 for the location of existing underground utilities. Contact shall be made a minimum of two (2) and no more than ten (10) business days prior to excavation. The contractor shall submit Excavation Locate Requests to the Kentucky Contact Center (KY 811) via web ticket entry. The submission of this request does not relieve the contractor from the responsibility of contacting non-member facility owners, whom are to be contacted through their individual Protection Notification Center. It may be necessary for the contractor to contact the County Court Clerk to determine what utility companies have facilities in the area. Non-compliance with these directives can result in the enforcement of penalties.

UTILITIES AND RAIL CERTIFICATION NOTE

Fayette County
7-20010.00 NHPP 0645 (081)
FD52 034 US-0064 081-083
Mile point: 81.037 TO 82.19
Address pavement condition of I-64 both directions

NOTE: DO NOT DISTURB THE FOLLOWING FACILITIES LOCATED WITHIN THE PROJECT DISTURB LIMITS

Kentucky Utilities

Kentucky American Water Company

Windstream Kentucky East

Spectrum

Columbia Gas of Kentucky

Lexington Fayette Urban County Government

AT&T KY

AT&T Legacy

THE FOLLOWING FACILITY OWNERS ARE RELOCATING/ADJUSTING THEIR FACILITIES WITHIN THE PROJECT LIMITS AND WILL BE COMPLETE PRIOR TO CONSTRUCTION

Not Applicable

THE FOLLOWING FACILITY OWNERS HAVE FACILITIES TO BE RELOCATED/ADJUSTED BY THE OWNER OR THEIR SUBCONTRACTOR AND IS TO BE COORDINATED WITH THE ROAD CONTRACT

Not Applicable

THE FOLLOWING FACILITY OWNERS HAVE FACILITIES TO BE RELOCATED/ADJUSTED BY THE ROAD CONTRACTOR AS INCLUDED IN THIS CONTRACT

UTILITIES AND RAIL CERTIFICATION NOTE

<p style="text-align: center;">Fayette County 7-20010.00 NHPP 0645 (081) FD52 034 US-0064 081-083 Mile point: 81.037 TO 82.19 Address pavement condition of I-64 both directions</p>

Not Applicable

RAIL COMPANIES HAVE FACILITIES IN CONJUNCTION WITH THIS PROJECT AS NOTED

No Rail Involvement Rail Involved Rail Adjacent

UTILITIES AND RAIL CERTIFICATION NOTE

Fayette County
7-20010.00 NHPP 0645 (081)
FD52 034 US-0064 081-083
Mile point: 81.037 TO 82.19
Address pavement condition of I-64 both directions

AREA FACILITY OWNER CONTACT LIST

Facility Owner	Address	Contact Name	Phone	Email
Kentucky Utilities		Caroline Justice	502 627 3708	
KAWC		Krista Citron	859 268 6352	
Windstream		Steve Johnson	859 867 6209	
Spectrum		Kelly Oram	859 519 3434	
Columbia Gas		Bryan Slone	859 288 0253	
LFUCG		Bob Bayert	859 258 3410	
AT&T KY		Frank Ambrose	502 867 8240	
AT&T Legacy		Mike Diederich	216 750 0135	

UTILITIES AND RAIL CERTIFICATION NOTE

Fayette County
7-20013.00 NHPP 0645 (081)
FD52 034 US-0075 0107-112
Mile point: 107.453 TO 110.213
Address pavement condition of I-75 both directions

PROJECT NOTES ON UTILITIES

Please Note: The information presented in this Utility Note is informational in nature and the information contained herein is not guaranteed.

The contractor will be responsible for contacting all utility facility owners on the subject project to coordinate his activities. The contractor will coordinate his activities to minimize and, where possible, avoid conflicts with utility facilities. Due to the nature of the work proposed, it is unlikely to conflict with the existing utilities beyond minor facility adjustments. Where conflicts with utility facilities are unavoidable, the contractor will coordinate any necessary relocation work with the facility owner and Resident Engineer. The Kentucky Transportation Cabinet maintains the right to remove or alter portions of this contract if a utility conflict occurs. The utility facilities as noted in the previous section(s) have been determined using data garnered by varied means and with varying degrees of accuracy: from the facility owners, a result of S.U.E., field inspections, and/or reviews of record drawings. The facilities defined may not be inclusive of all utilities in the project scope and are not Level A quality, unless specified as such. It is the contractor's responsibility to verify all utilities and their respective locations before excavating.

The contractor shall make every effort to protect underground facilities from damage as prescribed in the Underground Facility Damage Protection Act of 1994, Kentucky Revised Statute KRS 367.4901 to 367.4917. It is the contractor's responsibility to determine and take steps necessary to be in compliance with federal and state damage prevention directives. The contractor is instructed to contact KY 811 for the location of existing underground utilities. Contact shall be made a minimum of two (2) and no more than ten (10) business days prior to excavation. The contractor shall submit Excavation Locate Requests to the Kentucky Contact Center (KY 811) via web ticket entry. The submission of this request does not relieve the contractor from the responsibility of contacting non-member facility owners, whom are to be contacted through their individual Protection Notification Center. It may be necessary for the contractor to contact the County Court Clerk to determine what utility companies have facilities in the area. Non-compliance with these directives can result in the enforcement of penalties.

UTILITIES AND RAIL CERTIFICATION NOTE

Fayette County
7-20013.00 NHPP 0645 (081)
FD52 034 US-0075 0107-112
Mile point: 107.453 TO 110.213
Address pavement condition of I-75 both directions

NOTE: DO NOT DISTURB THE FOLLOWING FACILITIES LOCATED WITHIN THE PROJECT DISTURB LIMITS

Kentucky Utilities
Kentucky American Water Company
Windstream Kentucky East
Spectrum
Columbia Gas of Kentucky
Lexington Fayette Urban County Government
AT&T KY
AT&T Legacy

THE FOLLOWING FACILITY OWNERS ARE RELOCATING/ADJUSTING THEIR FACILITIES WITHIN THE PROJECT LIMITS AND WILL BE COMPLETE PRIOR TO CONSTRUCTION

Not Applicable

THE FOLLOWING FACILITY OWNERS HAVE FACILITIES TO BE RELOCATED/ADJUSTED BY THE OWNER OR THEIR SUBCONTRACTOR AND IS TO BE COORDINATED WITH THE ROAD CONTRACT

Not Applicable

THE FOLLOWING FACILITY OWNERS HAVE FACILITIES TO BE RELOCATED/ADJUSTED BY THE ROAD CONTRACTOR AS INCLUDED IN THIS CONTRACT

UTILITIES AND RAIL CERTIFICATION NOTE

<p style="text-align: center;">Fayette County 7-20013.00 NHPP 0645 (081) FD52 034 US-0075 0107-112 Mile point: 107.453 TO 110.213 Address pavement condition of I-75 both directions</p>

Not Applicable

RAIL COMPANIES HAVE FACILITIES IN CONJUNCTION WITH THIS PROJECT AS NOTED

No Rail Involvement Rail Involved Rail Adjacent

UTILITIES AND RAIL CERTIFICATION NOTE

Fayette County
7-20013.00 NHPP 0645 (081)
FD52 034 US-0075 0107-112
Mile point: 107.453 TO 110.213
Address pavement condition of I-75 both directions

AREA FACILITY OWNER CONTACT LIST

Facility Owner	Address	Contact Name	Phone	Email
Kentucky Utilities		Caroline Justice	502 627 3708	
KAWC		Krista Citron	859 268 6352	
Windstream		Steve Johnson	859 867 6209	
Spectrum		Kelly Oram	859 519 3434	
Columbia Gas		Bryan Slone	859 288 0253	
LFUCG		Bob Bayert	859 258 3410	
AT&T KY		Frank Ambrose	502 867 8240	
AT&T Legacy		Mike Diederich	216 750 0135	

MATERIAL SUMMARY

CONTRACT ID: 211049

034GR21D049-NHPP

DE03400642149

I-64 ADDRESS PAVEMENT CONDITION ON I-64 IN BOTH DIRECTIONS FROM MP 81.037 TO MP 82.19 IN FAYETTE COUNTY JPC PAVEMENT REPAIRS - DIAMOND GRINDING, A DISTANCE OF 1.15 MILES.

Project Line No	Bid Code	DESCRIPTION	Quantity	Unit
0410	00001	DGA BASE	100.00	TON
0415	00078	CRUSHED AGGREGATE SIZE NO 2	10.00	TON
0420	00194	LEVELING & WEDGING PG76-22	10.00	TON
0425	00216	CL3 ASPH BASE 1.00D PG76-22	18.00	TON
0430	00342	CL4 ASPH SURF 0.38A PG76-22	1,310.00	TON
0435	00356	ASPHALT MATERIAL FOR TACK	7.00	TON
0440	02058	REMOVE PCC PAVEMENT	2,611.00	SQYD
0445	02060	PCC PAVEMENT DIAMOND GRINDING	47,774.00	SQYD
0450	02071	JPC PAVEMENT-11 IN	2,611.00	SQYD
0455	02091	REMOVE PAVEMENT	38.00	SQYD
0460	02676	MOBILIZATION FOR MILL & TEXT	1.00	LS
0465	02677	ASPHALT PAVE MILLING & TEXTURING	1,310.00	TON
0470	20263ED	GEOGRID REINFORCEMENT - FOR ASPHALT	38.00	SQYD
0475	24891EC	PAVE MOUNT INFRARED TEMP EQUIPMENT	142,947.00	SF
0480	01985	DELINEATOR FOR BARRIER - YELLOW	12.00	EACH
0485	02115	SAW-CLEAN-RESEAL TVERSE JOINT	56,577.00	LF
0490	02116	SAW-CLEAN-RESEAL LONGIT JOINT	51,860.00	LF
0495	02237	DITCHING	6,088.00	LF
0500	02383	REMOVE & RESET GUARDRAIL	200.00	LF
0505	02562	TEMPORARY SIGNS	2,500.00	SQFT
0510	02650	MAINTAIN & CONTROL TRAFFIC	1.00	LS
0515	02775	ARROW PANEL	4.00	EACH
0520	05964	MAINTENANCE FERTILIZER	1.00	TON
0525	05985	SEEDING AND PROTECTION	100.00	SQYD
0530	06401	FLEXIBLE DELINEATOR POST-M/W	306.00	EACH
0535	06404	FLEXIBLE DELINEATOR POST-M/Y	288.00	EACH
0540	06412	STEEL POST MILE MARKERS	2.00	EACH
0545	06511	PAVE STRIPING-TEMP PAINT-6 IN	49,196.00	LF
0550	06542	PAVE STRIPING-THERMO-6 IN W	4,888.00	LF
0555	06543	PAVE STRIPING-THERMO-6 IN Y	3,398.00	LF
0560	06546	PAVE STRIPING-THERMO-12 IN W	3,733.00	LF
0565	06556	PAVE STRIPING-DUR TY 1-6 IN W	19,803.00	LF
0570	06557	PAVE STRIPING-DUR TY 1-6 IN Y	15,703.00	LF
0575	06560	PAVE STRIPING-DUR TY 1-12 IN W	1,671.00	LF
0580	06578	PAVE MARKING-THERMO MERGE ARROW	6.00	EACH
0585	06592	PAVEMENT MARKER TYPE V-B W/R	251.00	EACH
0590	06593	PAVEMENT MARKER TYPE V-B Y/R	198.00	EACH
0595	06600	REMOVE PAVEMENT MARKER TYPE V	449.00	EACH
0600	06613	INLAID PAVEMENT MARKER-B W/R	140.00	EACH
0605	06614	INLAID PAVEMENT MARKER-B Y/R	44.00	EACH
0610	10020NS	FUEL ADJUSTMENT	390.00	DOLL
0615	20071EC	JOINT ADHESIVE	12,050.00	LF
0620	20411ED	LAW ENFORCEMENT OFFICER	250.00	HOURL

MATERIAL SUMMARY

Project Line No	Bid Code	DESCRIPTION	Quantity	Unit
0625	20430ED	SAW CUT - RUMBLE STRIPE	6,981.00	LF
0630	21173EC	SAW-CLEAN-RESEAL RANDOM CRACKS	158.00	LF
0635	22664EN	WATER BLASTING EXISTING STRIPE	49,196.00	LF
0640	22883EN	CONCRETE WEDGE CURB	200.00	LF
0645	24679ED	PAVE MARK THERMO CHEVRON	2,603.00	SQFT
0650	24997EC	PARTIAL DEPTH PATCHING-POLYMER MOD	178.00	CUFT
0655	25075EC	QUEUE PROTECTION VEHICLE	480.00	HOURL
0660	25117EC	FURNISH QUEUE PROTECTION VEHICLES	3.00	MONT
0665	26136EC	PORTABLE QUEUE WARNING ALERT SYSTEM	3.00	MONT
0670	26137EC	QUEUE WARNING PCMS	12.00	MONT
0675	26138EC	QUEUE WARNING PORTABLE RADAR SENSORS	12.00	MONT
0680	01000	PERFORATED PIPE-4 IN	100.00	LF
0685	01010	NON-PERFORATED PIPE-4 IN	20.00	LF
0690	01020	PERF PIPE HEADWALL TY 1-4 IN	1.00	EACH
0695	01028	PERF PIPE HEADWALL TY 3-4 IN	1.00	EACH
0700	01691	FLUME INLET TYPE 2	1.00	EACH
0705	02220	FLOWABLE FILL	2.00	CUYD
0710	02483	CHANNEL LINING CLASS II	10.00	TON
0715	02484	CHANNEL LINING CLASS III	3.00	TON
0720	02602	FABRIC-GEOTEXTILE CLASS 1	100.00	SQYD
0725	02604	FABRIC-GEOTEXTILE CLASS 1A	100.00	SQYD
0730	02701	TEMP SILT FENCE	100.00	LF
0735	05950	EROSION CONTROL BLANKET	100.00	SQYD
0740	20366NN	REPLACE GRATE	1.00	EACH
0745	02568	MOBILIZATION	1.00	LS
0750	02569	DEMOBILIZATION	1.00	LS

CONTRACT ID: 211049

034GR21D049-NHPP

DE03400752149

I-75 ADDRESS PAVEMENT CONDITION ON I-75 IN BOTH DIRECTIONS FROM MP 107.453 TO MP 111.95 IN FAYETTE COUNTY ASPHALT REHAB INTERSTATE/PARKWAY, A DISTANCE OF 4.5 MILES.

Project Line No	Bid Code	DESCRIPTION	Quantity	Unit
0005	00001	DGA BASE	300.00	TON
0010	00078	CRUSHED AGGREGATE SIZE NO 2	40.00	TON
0015	00194	LEVELING & WEDGING PG76-22	500.00	TON
0020	00216	CL3 ASPH BASE 1.00D PG76-22	243.00	TON
0025	00342	CL4 ASPH SURF 0.38A PG76-22	23,771.00	TON
0030	00356	ASPHALT MATERIAL FOR TACK	121.00	TON
0035	02091	REMOVE PAVEMENT	519.00	SQYD
0040	02676	MOBILIZATION FOR MILL & TEXT	1.00	LS
0045	02677	ASPHALT PAVE MILLING & TEXTURING	23,771.00	TON
0050	20263ED	GEOGRID REINFORCEMENT - FOR ASPHALT	519.00	SQYD
0055	24891EC	PAVE MOUNT INFRARED TEMP EQUIPMENT	2,593,206.00	SF
0060	01484	CURB BOX INLET TYPE B-T	1.00	EACH
0065	01984	DELINEATOR FOR BARRIER - WHITE	44.00	EACH
0070	01985	DELINEATOR FOR BARRIER - YELLOW	290.00	EACH

MATERIAL SUMMARY

Project Line No	Bid Code	DESCRIPTION	Quantity	Unit
0075	02237	DITCHING	23,744.00	LF
0080	02351	GUARDRAIL-STEEL W BEAM-S FACE	175.00	LF
0085	02369	GUARDRAIL END TREATMENT TYPE 2A	1.00	EACH
0090	02383	REMOVE & RESET GUARDRAIL	1,762.00	LF
0095	02387	GUARDRAIL CONNECTOR TO BRIDGE END TY A-1	1.00	EACH
0100	02562	TEMPORARY SIGNS	5,000.00	SQFT
0105	02650	MAINTAIN & CONTROL TRAFFIC	1.00	LS
0110	02671	PORTABLE CHANGEABLE MESSAGE SIGN	6.00	EACH
0115	02775	ARROW PANEL	8.00	EACH
0120	05964	MAINTENANCE FERTILIZER	4.00	TON
0125	05985	SEEDING AND PROTECTION	200.00	SQYD
0130	06401	FLEXIBLE DELINEATOR POST-M/W	846.00	EACH
0135	06404	FLEXIBLE DELINEATOR POST-M/Y	342.00	EACH
0140	06412	STEEL POST MILE MARKERS	8.00	EACH
0145	06511	PAVE STRIPING-TEMP PAINT-6 IN	151,793.00	LF
0150	06542	PAVE STRIPING-THERMO-6 IN W	87,016.00	LF
0155	06543	PAVE STRIPING-THERMO-6 IN Y	55,407.00	LF
0160	06546	PAVE STRIPING-THERMO-12 IN W	5,824.00	LF
0165	06556	PAVE STRIPING-DUR TY 1-6 IN W	2,136.00	LF
0170	06557	PAVE STRIPING-DUR TY 1-6 IN Y	1,410.00	LF
0175	06568	PAVE MARKING-THERMO STOP BAR-24IN	110.00	LF
0180	06574	PAVE MARKING-THERMO CURV ARROW	42.00	EACH
0185	06578	PAVE MARKING-THERMO MERGE ARROW	6.00	EACH
0190	06613	INLAID PAVEMENT MARKER-B W/R	1,258.00	EACH
0195	06614	INLAID PAVEMENT MARKER-B Y/R	110.00	EACH
0200	10020NS	FUEL ADJUSTMENT	33,514.00	DOLL
0205	10030NS	ASPHALT ADJUSTMENT	59,058.00	DOLL
0210	20071EC	JOINT ADHESIVE	227,129.00	LF
0215	20362ES403	SHOULDER RUMBLE STRIPS-SAWED	19,590.00	LF
0220	20411ED	LAW ENFORCEMENT OFFICER	200.00	hour
0225	20430ED	SAW CUT - RUMBLE STRIPE	90,365.00	LF
0230	22664EN	WATER BLASTING EXISTING STRIPE	151,793.00	LF
0235	22883EN	CONCRETE WEDGE CURB	1,737.00	LF
0240	24679ED	PAVE MARK THERMO CHEVRON	2,092.00	SQFT
0245	24683ED	PAVE MARKING-THERMO DOTTED LANE EXTEN	1,053.00	LF
0250	24899EC	PAVE MARKING-THERMO ELONG ROUTE SHIELD	14.00	EACH
0255	25075EC	QUEUE PROTECTION VEHICLE	960.00	hour
0260	25117EC	FURNISH QUEUE PROTECTION VEHICLES	6.00	month
0265	26136EC	PORTABLE QUEUE WARNING ALERT SYSTEM	6.00	month
0270	26137EC	QUEUE WARNING PCMS	24.00	month
0275	26138EC	QUEUE WARNING PORTABLE RADAR SENSORS	24.00	month
0280	00461	CULVERT PIPE-15 IN	4.00	LF
0285	01000	PERFORATED PIPE-4 IN	200.00	LF
0290	01010	NON-PERFORATED PIPE-4 IN	40.00	LF
0295	01020	PERF PIPE HEADWALL TY 1-4 IN	2.00	EACH
0300	01028	PERF PIPE HEADWALL TY 3-4 IN	2.00	EACH
0305	01202	PIPE CULVERT HEADWALL-15 IN	1.00	EACH
0310	01691	FLUME INLET TYPE 2	6.00	EACH
0315	02220	FLOWABLE FILL	8.00	CUYD
0320	02483	CHANNEL LINING CLASS II	115.00	TON

MATERIAL SUMMARY

Project Line No	Bid Code	DESCRIPTION	Quantity	Unit
0325	02484	CHANNEL LINING CLASS III	75.00	TON
0330	02602	FABRIC-GEOTEXTILE CLASS 1	100.00	SQYD
0335	02604	FABRIC-GEOTEXTILE CLASS 1A	100.00	SQYD
0340	02701	TEMP SILT FENCE	200.00	LF
0345	05950	EROSION CONTROL BLANKET	400.00	SQYD
0350	20366NN	REPLACE GRATE	7.00	EACH
0355	04793	CONDUIT-1 1/4 IN	160.00	LF
0360	04795	CONDUIT-2 IN	40.00	LF
0365	04820	TRENCHING AND BACKFILLING	180.00	LF
0370	04829	PIEZOELECTRIC SENSOR	13.00	EACH
0375	04830	LOOP WIRE	5,900.00	LF
0380	04895	LOOP SAW SLOT AND FILL	1,190.00	LF
0385	20359NN	GALVANIZED STEEL CABINET	4.00	EACH
0390	20360ES818	WOOD POST	8.00	EACH
0395	20391NS835	ELECTRICAL JUNCTION BOX TYPE A	4.00	EACH
0400	02568	MOBILIZATION	1.00	LS
0405	02569	DEMOBILIZATION	1.00	LS

GUARDRAIL DELIVERY VERIFICATION SHEET

Contract Id: _____

Contractor: _____

Section Engineer: _____

District & County: _____

<u>DESCRIPTION</u>	<u>UNIT</u>	<u>QTY LEAVING PROJECT</u>	<u>QTY RECEIVED@BB YARD</u>
GUARDRAIL (Includes End treatments & crash cushions)	LF	_____	_____
STEEL POSTS	EACH	_____	_____
STEEL BLOCKS	EACH	_____	_____
WOOD OFFSET BLOCKS	EACH	_____	_____
BACK UP PLATES	EACH	_____	_____
CRASH CUSHION	EACH	_____	_____
NUTS, BOLTS, WASHERS	BAG/BCKT	_____	_____
DAMAGED RAIL TO MAINT. FACILITY	LF	_____	_____
DAMAGED POSTS TO MAINT. FACILITY	EACH	_____	_____

***Required Signatures before Leaving Project Site**

Printed Section Engineer's Representative _____ & Date _____

Signature Section Engineer's Representative _____ & Date _____

Printed Contractor's Representative _____ & Date _____

Signature Contractor's Representative _____ & Date _____

***Required Signatures after Arrival at Bailey Bridge Yard (All material on truck must be counted & the quantity received column completed before signatures)**

Printed Bailey Bridge Yard Representative _____ & Date _____

Signature Bailey Bridge Yard Representative _____ & Date _____

Printed Contractor's Representative _____ & Date _____

Signature Contractor's Representative _____ & Date _____

**Payment for the bid item remove guardrail will be based upon the quantities shown in the Bailey Bridge Yard received column. Payment will not be made for guardrail removal until the guardrail verification sheets are electronically submitted to the Section Engineer by the Bailey Bridge Yard Representative.

Completed Form Submitted to Section Engineer Date: _____ By: _____

PART II
SPECIFICATIONS AND STANDARD DRAWINGS

SPECIFICATIONS REFERENCE

Any reference in the plans or proposal to previous editions of the *Standard Specifications for Road and Bridge Construction* and *Standard Drawings* are superseded by *Standard Specifications for Road and Bridge Construction, Edition of 2019* and *Standard Drawings, Edition of 2020*.

SUPPLEMENTAL SPECIFICATIONS

The contractor shall use the Supplemental Specifications that are effective at the time of letting.
The Supplemental Specifications can be found at the following link:

<http://transportation.ky.gov/Construction/Pages/Kentucky-Standard-Specifications.aspx>

SPECIAL NOTE FOR PORTABLE CHANGEABLE MESSAGE SIGNS

This Special Note will apply when indicated on the plans or in the proposal.

1.0 DESCRIPTION. Furnish, install, operate, and maintain variable message signs at the locations shown on the plans or designated by the Engineer. Remove and retain possession of variable message signs when they are no longer needed on the project.

2.0 MATERIALS.

2.1 General. Use LED Variable Message Signs Class I, II, or III, as appropriate, from the Department's List of Approved Materials.

Unclassified signs may be submitted for approval by the Engineer. The Engineer may require a daytime and nighttime demonstration. The Engineer will make a final decision within 30 days after all required information is received.

2.2 Sign and Controls. All signs must:

- 1) Provide 3-line messages with each line being 8 characters long and at least 18 inches tall. Each character comprises 35 pixels.
- 2) Provide at least 40 preprogrammed messages available for use at any time. Provide for quick and easy change of the displayed message; editing of the message; and additions of new messages.
- 3) Provide a controller consisting of:
 - a) Keyboard or keypad.
 - b) Readout that mimics the actual sign display. (When LCD or LCD type readout is used, include backlighting and heating or otherwise arrange for viewing in cold temperatures.)
 - c) Non-volatile memory or suitable memory with battery backup for storing pre-programmed messages.
 - d) Logic circuitry to control the sequence of messages and flash rate.
- 4) Provide a serial interface that is capable of supporting complete remote control ability through land line and cellular telephone operation. Include communication software capable of immediately updating the message, providing complete sign status, and allowing message library queries and updates.
- 5) Allow a single person easily to raise the sign to a satisfactory height above the pavement during use, and lower the sign during travel.
- 6) Be Highway Orange on all exterior surfaces of the trailer, supports, and controller cabinet.
- 7) Provide operation in ambient temperatures from -30 to + 120 degrees Fahrenheit during snow, rain and other inclement weather.
- 8) Provide the driver board as part of a module. All modules are interchangeable, and have plug and socket arrangements for disconnection and reconnection. Printed circuit boards associated with driver boards have a conformable coating to protect against moisture.
- 9) Provide a sign case sealed against rain, snow, dust, insects, etc. The lens is UV stabilized clear plastic (polycarbonate, acrylic, or other approved material) angled to prevent glare.
- 10) Provide a flat black UV protected coating on the sign hardware, character PCB, and appropriate lens areas.
- 11) Provide a photocell control to provide automatic dimming.

- 12) Allow an on-off flashing sequence at an adjustable rate.
- 13) Provide a sight to aim the message.
- 14) Provide a LED display color of approximately 590 nm amber.
- 15) Provide a controller that is password protected.
- 16) Provide a security device that prevents unauthorized individuals from accessing the controller.
- 17) Provide the following 3-line messages preprogrammed and available for use when the sign unit begins operation:

/KEEP/RIGHT/=>=>=>/	/MIN/SPEED/**MPH/
/KEEP/LEFT/<=<=</	/ICY/BRIDGE/AHEAD/ /ONE
/LOOSE/GRAVEL/AHEAD/	LANE/BRIDGE/AHEAD/
/RD WORK/NEXT/**MILES/	/ROUGH/ROAD/AHEAD/
/TWO WAY/TRAFFIC/AHEAD/	/MERGING/TRAFFIC/AHEAD/
/PAINT/CREW/AHEAD/	/NEXT/***/MILES/
/REDUCE/SPEED/**MPH/	/HEAVY/TRAFFIC/AHEAD/
/BRIDGE/WORK/***0 FT/	/SPEED/LIMIT/**MPH/
/MAX/SPEED/**MPH/	/BUMP/AHEAD/
/SURVEY/PARTY/AHEAD/	/TWO/WAY/TRAFFIC/

*Insert numerals as directed by the Engineer.
Add other messages during the project when required by the Engineer.

2.3 Power.

- 1) Design solar panels to yield 10 percent or greater additional charge than sign consumption. Provide direct wiring for operation of the sign or arrow board from an external power source to provide energy backup for 21 days without sunlight and an on-board system charger with the ability to recharge completely discharged batteries in 24 hours.

3.0 CONSTRUCTION. Furnish and operate the variable message signs as designated on the plans or by the Engineer. Ensure the bottom of the message panel is a minimum of 7 feet above the roadway in urban areas and 5 feet above in rural areas when operating. Use Class I, II, or III signs on roads with a speed limit less than 55 mph. Use Class I or II signs on roads with speed limits 55 mph or greater.

Maintain the sign in proper working order, including repair of any damage done by others, until completion of the project. When the sign becomes inoperative, immediately repair or replace the sign. Repetitive problems with the same unit will be cause for rejection and replacement.

Use only project related messages and messages directed by the Engineer, unnecessary messages lessen the impact of the sign. Ensure the message is displayed in either one or 2 phases with each phase having no more than 3 lines of text. When no message is needed, but it is necessary to know if the sign is operable, flash only a pixel.

When the sign is not needed, move it outside the clear zone or where the Engineer directs. Variable Message Signs are the property of the Contractor and shall be removed from the project when no longer needed. The Department will not assume ownership of these signs.

4.0 MEASUREMENT. The final quantity of Variable Message Sign will be

11

the actual number of individual signs acceptably furnished and operated during the project. The Department will not measure signs replaced due to damage or rejection.

5.0 PAYMENT. The Department will pay for the Variable Message Signs at the unit price each. The Department will not pay for signs replaced due to damage or rejection. Payment is full compensation for furnishing all materials, labor, equipment, and service necessary to, operate, move, repair, and maintain or replace the variable message signs. The Department will make payment for the completed and accepted quantities under the following:

<u>Code</u>	<u>Pay Item</u>	<u>Pay Unit</u>
02671	Portable Changeable Message Sign	Each

Effective June 15, 2012

SPECIAL NOTE FOR LONGITUDINAL PAVEMENT JOINT ADHESIVE

1. DESCRIPTION. This specification covers the requirements and practices for applying an asphalt adhesive material to the longitudinal joint of the surface course of an asphalt pavement. Apply the adhesive to the face of longitudinal joint between driving lanes for the first lane paved. Then, place and compact the adjacent lane against the treated face to produce a strong, durable, waterproof longitudinal joint.
2. MATERIALS, EQUIPMENT, AND PERSONNEL.

2.1 Joint Adhesive. Provide material conforming to Subsection 2.1.1.

2.1.1 Provide an adhesive conforming to the following requirements:

Property	Specification	Test Procedure
Viscosity, 400 ° F (Pa·s)	4.0 – 10.0	ASTM D 4402
Cone Penetration, 77 ° F	60 – 100	ASTM D 5329
Flow, 140 ° F (mm)	5.0 max.	ASTM D 5329
Resilience, 77 ° F (%)	30 min.	ASTM D 5329
Ductility, 77 ° F (cm)	30.0 min.	ASTM D 113
Ductility, 39 ° F (cm)	30.0 min.	ASTM D 113
Tensile Adhesion, 77 ° F (%)	500 min.	ASTM D 5329, Type II
Softening Point, ° F	171 min.	AASHTO T 53
Asphalt Compatibility	Pass	ASTM D 5329

Ensure the temperature of the pavement joint adhesive is between 380 and 410 °F when the material is extruded in a 0.125-inch-thick band over the entire face of the longitudinal joint.

2.2. Equipment.

2.2.1 Melter Kettle. Provide an oil-jacketed, double-boiler, melter kettle equipped with any needed agitation and recirculating systems.

2.2.2 Applicator System. Provide a pressure-feed-wand applicator system with an applicator shoe attached.

2.3 Personnel. Ensure a technical representative from the manufacturer of the pavement joint adhesive is present during the initial construction activities and available upon the request of the Engineer.

3. CONSTRUCTION.

3.1 Surface Preparation. Prior to the application of the pavement joint adhesive, ensure the face of the longitudinal joint is thoroughly dry and free from dust or any other debris that would inhibit adhesion. Clean the joint face by the use of compressed air.

Ensure this preparation process occurs shortly before application to prevent the return of debris on the joint face.

3.2 Pavement Joint Adhesive Application. Ensure the ambient temperature is a minimum of 40 ° F during the application of the pavement joint adhesive. Prior to applying the adhesive, demonstrate competence in applying the adhesive according to this note to the satisfaction of the Engineer. Heat the adhesive in the melter kettle to the specified temperature range. Pump the adhesive from the melter kettle through the wand onto the vertical face of the cold joint. Apply the adhesive in a continuous band over the entire face of the longitudinal joint. Do not use excessive material in either thickness or location. Ensure the edge of the extruded adhesive material is flush with the surface of the pavement. Then, place and compact the adjacent lane against the joint face. Remove any excessive material extruded from the joint after compaction (a small line of material may remain).

3.3 Pavement Joint Adhesive Certification. Furnish the joint adhesive's certification to the Engineer stating the material conforms to all requirements herein prior to use.

3.4 Sampling and Testing. The Department will require a random sample of pavement joint adhesive from each manufacturer's lot of material. Extrude two 5 lb. samples of the heated material and forward the sample to the Division of Materials for testing. Reynolds oven bags, turkey size, placed inside small cardboard boxes or cement cylinder molds have been found suitable. Ensure the product temperature is 400°F or below at the time of sampling.

4. MEASUREMENT. The Department will measure the quantity of Pavement Joint Adhesive in linear feet. The Department will not measure for payment any extra materials, labor, methods, equipment, or construction techniques used to satisfy the requirements of this note. The Department will not measure for payment any trial applications of Pavement Joint Adhesive, the cleaning of the joint face, or furnishing and placing the adhesive. The Department will consider all such items incidental to the Pavement Joint Adhesive.
5. PAYMENT. The Department will pay for the Pavement Joint Adhesive at the Contract unit bid price and apply an adjustment for each manufacturer's lot of material based on the degree of compliance as defined in the following schedule. When a sample fails on two or more tests, the Department may add the deductions, but the total deduction will not exceed 100 percent.

11N

Pavement Joint Adhesive Price Adjustment Schedule						
Test	Specification	100% Pay	90% Pay	80% Pay	50% Pay	0% Pay
Joint Adhesive Referenced in Subsection 2.1.1						
Viscosity, 400 ° F (Pa•s) ASTM D 3236	4.0-10.0	3.5-10.5	3.0-3.4 10.6-11.0	2.5-2.9 11.1-11.5	2.0-2.4 11.6-12.0	≤1.9 ≥ 12.1
Cone Penetration, 77 ° F ASTM D 5329	60-100	57-103	54-56 104-106	51-53 107-109	48-50 110-112	≤ 47 ≥ 113
Flow, 140 ° F (mm) ASTM D 5329	≤ 5.0	≤ 5.5	5.6-6.0	6.1-6.5	6.6-7.0	≥ 7.1
Resilience, 77 ° F (%) ASTM D 5329	≥ 30	≥ 28	26-27	24-25	22-23	≤ 21
Tensile Adhesion, 77 ° F (%) ASTM D 5329	≥ 500	≥ 490	480-489	470-479	460-469	≤ 459
Softening Point, ° F AASHTO T 53	≥ 171	≥ 169	166-168	163-165	160-162	≤ 159
Ductility, 77 ° F (cm) ASTM D 113	≥ 30.0	≥ 29.0	28.0-28.9	27.0-27.9	26.0-26.9	≤ 25.9
Ductility, 39 ° F (cm) ASTM D 113	≥ 30.0	≥ 29.0	28.0-28.9	27.0-27.9	26.0-26.9	≤ 25.9

Code
20071EC

Pay Item
Joint Adhesive

Pay Unit
Linear Foot

May 7, 2014

PART III

EMPLOYMENT, WAGE AND RECORD REQUIREMENTS

FHWA-1273 -- Revised May 1, 2012

**REQUIRED CONTRACT PROVISIONS
FEDERAL-AID CONSTRUCTION CONTRACTS**

- I. General
- II. Nondiscrimination
- III. Nonsegregated Facilities
- IV. Davis-Bacon and Related Act Provisions
- V. Contract Work Hours and Safety Standards Act Provisions
- VI. Subletting or Assigning the Contract
- VII. Safety: Accident Prevention
- VIII. False Statements Concerning Highway Projects
- IX. Implementation of Clean Air Act and Federal Water Pollution Control Act
- X. Compliance with Governmentwide Suspension and Debarment Requirements
- XI. Certification Regarding Use of Contract Funds for Lobbying

3. A breach of any of the stipulations contained in these Required Contract Provisions may be sufficient grounds for withholding of progress payments, withholding of final payment, termination of the contract, suspension / debarment or any other action determined to be appropriate by the contracting agency and FHWA.

4. Selection of Labor: During the performance of this contract, the contractor shall not use convict labor for any purpose within the limits of a construction project on a Federal-aid highway unless it is labor performed by convicts who are on parole, supervised release, or probation. The term Federal-aid highway does not include roadways functionally classified as local roads or rural minor collectors.

ATTACHMENTS

A. Employment and Materials Preference for Appalachian Development Highway System or Appalachian Local Access Road Contracts (included in Appalachian contracts only)

II. NONDISCRIMINATION

The provisions of this section related to 23 CFR Part 230 are applicable to all Federal-aid construction contracts and to all related construction subcontracts of \$10,000 or more. The provisions of 23 CFR Part 230 are not applicable to material supply, engineering, or architectural service contracts.

I. GENERAL

1. Form FHWA-1273 must be physically incorporated in each construction contract funded under Title 23 (excluding emergency contracts solely intended for debris removal). The contractor (or subcontractor) must insert this form in each subcontract and further require its inclusion in all lower tier subcontracts (excluding purchase orders, rental agreements and other agreements for supplies or services).

In addition, the contractor and all subcontractors must comply with the following policies: Executive Order 11246, 41 CFR 60, 29 CFR 1625-1627, Title 23 USC Section 140, the Rehabilitation Act of 1973, as amended (29 USC 794), Title VI of the Civil Rights Act of 1964, as amended, and related regulations including 49 CFR Parts 21, 26 and 27; and 23 CFR Parts 200, 230, and 633.

The applicable requirements of Form FHWA-1273 are incorporated by reference for work done under any purchase order, rental agreement or agreement for other services. The prime contractor shall be responsible for compliance by any subcontractor, lower-tier subcontractor or service provider.

The contractor and all subcontractors must comply with: the requirements of the Equal Opportunity Clause in 41 CFR 60-1.4(b) and, for all construction contracts exceeding \$10,000, the Standard Federal Equal Employment Opportunity Construction Contract Specifications in 41 CFR 60-4.3.

Form FHWA-1273 must be included in all Federal-aid design-build contracts, in all subcontracts and in lower tier subcontracts (excluding subcontracts for design services, purchase orders, rental agreements and other agreements for supplies or services). The design-builder shall be responsible for compliance by any subcontractor, lower-tier subcontractor or service provider.

Note: The U.S. Department of Labor has exclusive authority to determine compliance with Executive Order 11246 and the policies of the Secretary of Labor including 41 CFR 60, and 29 CFR 1625-1627. The contracting agency and the FHWA have the authority and the responsibility to ensure compliance with Title 23 USC Section 140, the Rehabilitation Act of 1973, as amended (29 USC 794), and Title VI of the Civil Rights Act of 1964, as amended, and related regulations including 49 CFR Parts 21, 26 and 27; and 23 CFR Parts 200, 230, and 633.

Contracting agencies may reference Form FHWA-1273 in bid proposal or request for proposal documents, however, the Form FHWA-1273 must be physically incorporated (not referenced) in all contracts, subcontracts and lower-tier subcontracts (excluding purchase orders, rental agreements and other agreements for supplies or services related to a construction contract).

The following provision is adopted from 23 CFR 230, Appendix A, with appropriate revisions to conform to the U.S. Department of Labor (US DOL) and FHWA requirements.

2. Subject to the applicability criteria noted in the following sections, these contract provisions shall apply to all work performed on the contract by the contractor's own organization and with the assistance of workers under the contractor's immediate superintendence and to all work performed on the contract by piecework, station work, or by subcontract.

1. Equal Employment Opportunity: Equal employment opportunity (EEO) requirements not to discriminate and to take affirmative action to assure equal opportunity as set forth under laws, executive orders, rules, regulations (28 CFR 35, 29 CFR 1630, 29 CFR 1625-1627, 41 CFR 60 and 49 CFR 27) and orders of the Secretary of Labor as modified by the provisions prescribed herein, and imposed pursuant to 23 U.S.C. 140 shall constitute the EEO and specific affirmative action standards for the contractor's project activities under

this contract. The provisions of the Americans with Disabilities Act of 1990 (42 U.S.C. 12101 et seq.) set forth under 28 CFR 35 and 29 CFR 1630 are incorporated by reference in this contract. In the execution of this contract, the contractor agrees to comply with the following minimum specific requirement activities of EEO:

a. The contractor will work with the contracting agency and the Federal Government to ensure that it has made every good faith effort to provide equal opportunity with respect to all of its terms and conditions of employment and in their review of activities under the contract.

b. The contractor will accept as its operating policy the following statement:

"It is the policy of this Company to assure that applicants are employed, and that employees are treated during employment, without regard to their race, religion, sex, color, national origin, age or disability. Such action shall include: employment, upgrading, demotion, or transfer; recruitment or recruitment advertising; layoff or termination; rates of pay or other forms of compensation; and selection for training, including apprenticeship, pre-apprenticeship, and/or on-the-job training."

2. EEO Officer: The contractor will designate and make known to the contracting officers an EEO Officer who will have the responsibility for and must be capable of effectively administering and promoting an active EEO program and who must be assigned adequate authority and responsibility to do so.

3. Dissemination of Policy: All members of the contractor's staff who are authorized to hire, supervise, promote, and discharge employees, or who recommend such action, or who are substantially involved in such action, will be made fully cognizant of, and will implement, the contractor's EEO policy and contractual responsibilities to provide EEO in each grade and classification of employment. To ensure that the above agreement will be met, the following actions will be taken as a minimum:

a. Periodic meetings of supervisory and personnel office employees will be conducted before the start of work and then not less often than once every six months, at which time the contractor's EEO policy and its implementation will be reviewed and explained. The meetings will be conducted by the EEO Officer.

b. All new supervisory or personnel office employees will be given a thorough indoctrination by the EEO Officer, covering all major aspects of the contractor's EEO obligations within thirty days following their reporting for duty with the contractor.

c. All personnel who are engaged in direct recruitment for the project will be instructed by the EEO Officer in the contractor's procedures for locating and hiring minorities and women.

d. Notices and posters setting forth the contractor's EEO policy will be placed in areas readily accessible to employees, applicants for employment and potential employees.

e. The contractor's EEO policy and the procedures to implement such policy will be brought to the attention of employees by means of meetings, employee handbooks, or other appropriate means.

4. Recruitment: When advertising for employees, the contractor will include in all advertisements for employees the notation: "An Equal Opportunity Employer." All such advertisements will be placed in publications having a large circulation among minorities and women in the area from which the project work force would normally be derived.

a. The contractor will, unless precluded by a valid bargaining agreement, conduct systematic and direct recruitment through public and private employee referral sources likely to yield qualified minorities and women. To meet this requirement, the contractor will identify sources of potential minority group employees, and establish with such identified sources procedures whereby minority and women applicants may be referred to the contractor for employment consideration.

b. In the event the contractor has a valid bargaining agreement providing for exclusive hiring hall referrals, the contractor is expected to observe the provisions of that agreement to the extent that the system meets the contractor's compliance with EEO contract provisions. Where implementation of such an agreement has the effect of discriminating against minorities or women, or obligates the contractor to do the same, such implementation violates Federal nondiscrimination provisions.

c. The contractor will encourage its present employees to refer minorities and women as applicants for employment. Information and procedures with regard to referring such applicants will be discussed with employees.

5. Personnel Actions: Wages, working conditions, and employee benefits shall be established and administered, and personnel actions of every type, including hiring, upgrading, promotion, transfer, demotion, layoff, and termination, shall be taken without regard to race, color, religion, sex, national origin, age or disability. The following procedures shall be followed:

a. The contractor will conduct periodic inspections of project sites to insure that working conditions and employee facilities do not indicate discriminatory treatment of project site personnel.

b. The contractor will periodically evaluate the spread of wages paid within each classification to determine any evidence of discriminatory wage practices.

c. The contractor will periodically review selected personnel actions in depth to determine whether there is evidence of discrimination. Where evidence is found, the contractor will promptly take corrective action. If the review indicates that the discrimination may extend beyond the actions reviewed, such corrective action shall include all affected persons.

d. The contractor will promptly investigate all complaints of alleged discrimination made to the contractor in connection with its obligations under this contract, will attempt to resolve such complaints, and will take appropriate corrective action within a reasonable time. If the investigation indicates that the discrimination may affect persons other than the complainant, such corrective action shall include such other persons. Upon completion of each investigation, the contractor will inform every complainant of all of their avenues of appeal.

6. Training and Promotion:

a. The contractor will assist in locating, qualifying, and increasing the skills of minorities and women who are

applicants for employment or current employees. Such efforts should be aimed at developing full journey level status employees in the type of trade or job classification involved.

b. Consistent with the contractor's work force requirements and as permissible under Federal and State regulations, the contractor shall make full use of training programs, i.e., apprenticeship, and on-the-job training programs for the geographical area of contract performance. In the event a special provision for training is provided under this contract, this subparagraph will be superseded as indicated in the special provision. The contracting agency may reserve training positions for persons who receive welfare assistance in accordance with 23 U.S.C. 140(a).

c. The contractor will advise employees and applicants for employment of available training programs and entrance requirements for each.

d. The contractor will periodically review the training and promotion potential of employees who are minorities and women and will encourage eligible employees to apply for such training and promotion.

7. Unions: If the contractor relies in whole or in part upon unions as a source of employees, the contractor will use good faith efforts to obtain the cooperation of such unions to increase opportunities for minorities and women. Actions by the contractor, either directly or through a contractor's association acting as agent, will include the procedures set forth below:

a. The contractor will use good faith efforts to develop, in cooperation with the unions, joint training programs aimed toward qualifying more minorities and women for membership in the unions and increasing the skills of minorities and women so that they may qualify for higher paying employment.

b. The contractor will use good faith efforts to incorporate an EEO clause into each union agreement to the end that such union will be contractually bound to refer applicants without regard to their race, color, religion, sex, national origin, age or disability.

c. The contractor is to obtain information as to the referral practices and policies of the labor union except that to the extent such information is within the exclusive possession of the labor union and such labor union refuses to furnish such information to the contractor, the contractor shall so certify to the contracting agency and shall set forth what efforts have been made to obtain such information.

d. In the event the union is unable to provide the contractor with a reasonable flow of referrals within the time limit set forth in the collective bargaining agreement, the contractor will, through independent recruitment efforts, fill the employment vacancies without regard to race, color, religion, sex, national origin, age or disability; making full efforts to obtain qualified and/or qualifiable minorities and women. The failure of a union to provide sufficient referrals (even though it is obligated to provide exclusive referrals under the terms of a collective bargaining agreement) does not relieve the contractor from the requirements of this paragraph. In the event the union referral practice prevents the contractor from meeting the obligations pursuant to Executive Order 11246, as amended, and these special provisions, such contractor shall immediately notify the contracting agency.

8. Reasonable Accommodation for Applicants / Employees with Disabilities: The contractor must be familiar

with the requirements for and comply with the Americans with Disabilities Act and all rules and regulations established there under. Employers must provide reasonable accommodation in all employment activities unless to do so would cause an undue hardship.

9. Selection of Subcontractors, Procurement of Materials and Leasing of Equipment: The contractor shall not discriminate on the grounds of race, color, religion, sex, national origin, age or disability in the selection and retention of subcontractors, including procurement of materials and leases of equipment. The contractor shall take all necessary and reasonable steps to ensure nondiscrimination in the administration of this contract.

a. The contractor shall notify all potential subcontractors and suppliers and lessors of their EEO obligations under this contract.

b. The contractor will use good faith efforts to ensure subcontractor compliance with their EEO obligations.

10. Assurance Required by 49 CFR 26.13(b):

a. The requirements of 49 CFR Part 26 and the State DOT's U.S. DOT-approved DBE program are incorporated by reference.

b. The contractor or subcontractor shall not discriminate on the basis of race, color, national origin, or sex in the performance of this contract. The contractor shall carry out applicable requirements of 49 CFR Part 26 in the award and administration of DOT-assisted contracts. Failure by the contractor to carry out these requirements is a material breach of this contract, which may result in the termination of this contract or such other remedy as the contracting agency deems appropriate.

11. Records and Reports: The contractor shall keep such records as necessary to document compliance with the EEO requirements. Such records shall be retained for a period of three years following the date of the final payment to the contractor for all contract work and shall be available at reasonable times and places for inspection by authorized representatives of the contracting agency and the FHWA.

a. The records kept by the contractor shall document the following:

(1) The number and work hours of minority and non-minority group members and women employed in each work classification on the project;

(2) The progress and efforts being made in cooperation with unions, when applicable, to increase employment opportunities for minorities and women; and

(3) The progress and efforts being made in locating, hiring, training, qualifying, and upgrading minorities and women;

b. The contractors and subcontractors will submit an annual report to the contracting agency each July for the duration of the project, indicating the number of minority, women, and non-minority group employees currently engaged in each work classification required by the contract work. This information is to be reported on [Form FHWA-1391](#). The staffing data should represent the project work force on board in all or any part of the last payroll period preceding the end of July. If on-the-job training is being required by special provision, the contractor

will be required to collect and report training data. The employment data should reflect the work force on board during all or any part of the last payroll period preceding the end of July.

III. NONSEGREGATED FACILITIES

This provision is applicable to all Federal-aid construction contracts and to all related construction subcontracts of \$10,000 or more.

The contractor must ensure that facilities provided for employees are provided in such a manner that segregation on the basis of race, color, religion, sex, or national origin cannot result. The contractor may neither require such segregated use by written or oral policies nor tolerate such use by employee custom. The contractor's obligation extends further to ensure that its employees are not assigned to perform their services at any location, under the contractor's control, where the facilities are segregated. The term "facilities" includes waiting rooms, work areas, restaurants and other eating areas, time clocks, restrooms, washrooms, locker rooms, and other storage or dressing areas, parking lots, drinking fountains, recreation or entertainment areas, transportation, and housing provided for employees. The contractor shall provide separate or single-user restrooms and necessary dressing or sleeping areas to assure privacy between sexes.

IV. DAVIS-BACON AND RELATED ACT PROVISIONS

This section is applicable to all Federal-aid construction projects exceeding \$2,000 and to all related subcontracts and lower-tier subcontracts (regardless of subcontract size). The requirements apply to all projects located within the right-of-way of a roadway that is functionally classified as Federal-aid highway. This excludes roadways functionally classified as local roads or rural minor collectors, which are exempt. Contracting agencies may elect to apply these requirements to other projects.

The following provisions are from the U.S. Department of Labor regulations in 29 CFR 5.5 "Contract provisions and related matters" with minor revisions to conform to the FHWA-1273 format and FHWA program requirements.

1. Minimum wages

a. All laborers and mechanics employed or working upon the site of the work, will be paid unconditionally and not less often than once a week, and without subsequent deduction or rebate on any account (except such payroll deductions as are permitted by regulations issued by the Secretary of Labor under the Copeland Act (29 CFR part 3)), the full amount of wages and bona fide fringe benefits (or cash equivalents thereof) due at time of payment computed at rates not less than those contained in the wage determination of the Secretary of Labor which is attached hereto and made a part hereof, regardless of any contractual relationship which may be alleged to exist between the contractor and such laborers and mechanics.

Contributions made or costs reasonably anticipated for bona fide fringe benefits under section 1(b)(2) of the Davis-Bacon Act on behalf of laborers or mechanics are considered wages paid to such laborers or mechanics, subject to the provisions

of paragraph 1.d. of this section; also, regular contributions made or costs incurred for more than a weekly period (but not less often than quarterly) under plans, funds, or programs which cover the particular weekly period, are deemed to be constructively made or incurred during such weekly period. Such laborers and mechanics shall be paid the appropriate wage rate and fringe benefits on the wage determination for the classification of work actually performed, without regard to skill, except as provided in 29 CFR 5.5(a)(4). Laborers or mechanics performing work in more than one classification may be compensated at the rate specified for each classification for the time actually worked therein: Provided, That the employer's payroll records accurately set forth the time spent in each classification in which work is performed. The wage determination (including any additional classification and wage rates conformed under paragraph 1.b. of this section) and the Davis-Bacon poster (WH-1321) shall be posted at all times by the contractor and its subcontractors at the site of the work in a prominent and accessible place where it can be easily seen by the workers.

b.(1) The contracting officer shall require that any class of laborers or mechanics, including helpers, which is not listed in the wage determination and which is to be employed under the contract shall be classified in conformance with the wage determination. The contracting officer shall approve an additional classification and wage rate and fringe benefits therefore only when the following criteria have been met:

- (i) The work to be performed by the classification requested is not performed by a classification in the wage determination; and
- (ii) The classification is utilized in the area by the construction industry; and
- (iii) The proposed wage rate, including any bona fide fringe benefits, bears a reasonable relationship to the wage rates contained in the wage determination.

(2) If the contractor and the laborers and mechanics to be employed in the classification (if known), or their representatives, and the contracting officer agree on the classification and wage rate (including the amount designated for fringe benefits where appropriate), a report of the action taken shall be sent by the contracting officer to the Administrator of the Wage and Hour Division, Employment Standards Administration, U.S. Department of Labor, Washington, DC 20210. The Administrator, or an authorized representative, will approve, modify, or disapprove every additional classification action within 30 days of receipt and so advise the contracting officer or will notify the contracting officer within the 30-day period that additional time is necessary.

(3) In the event the contractor, the laborers or mechanics to be employed in the classification or their representatives, and the contracting officer do not agree on the proposed classification and wage rate (including the amount designated for fringe benefits, where appropriate), the contracting officer shall refer the questions, including the views of all interested parties and the recommendation of the contracting officer, to the Wage and Hour Administrator for determination. The Wage and Hour Administrator, or an authorized representative, will issue a determination within 30 days of receipt and so advise the contracting officer or

will notify the contracting officer within the 30-day period that additional time is necessary.

(4) The wage rate (including fringe benefits where appropriate) determined pursuant to paragraphs 1.b.(2) or 1.b.(3) of this section, shall be paid to all workers performing work in the classification under this contract from the first day on which work is performed in the classification.

c. Whenever the minimum wage rate prescribed in the contract for a class of laborers or mechanics includes a fringe benefit which is not expressed as an hourly rate, the contractor shall either pay the benefit as stated in the wage determination or shall pay another bona fide fringe benefit or an hourly cash equivalent thereof.

d. If the contractor does not make payments to a trustee or other third person, the contractor may consider as part of the wages of any laborer or mechanic the amount of any costs reasonably anticipated in providing bona fide fringe benefits under a plan or program. Provided, That the Secretary of Labor has found, upon the written request of the contractor, that the applicable standards of the Davis-Bacon Act have been met. The Secretary of Labor may require the contractor to set aside in a separate account assets for the meeting of obligations under the plan or program.

2. Withholding

The contracting agency shall upon its own action or upon written request of an authorized representative of the Department of Labor, withhold or cause to be withheld from the contractor under this contract, or any other Federal contract with the same prime contractor, or any other federally-assisted contract subject to Davis-Bacon prevailing wage requirements, which is held by the same prime contractor, so much of the accrued payments or advances as may be considered necessary to pay laborers and mechanics, including apprentices, trainees, and helpers, employed by the contractor or any subcontractor the full amount of wages required by the contract. In the event of failure to pay any laborer or mechanic, including any apprentice, trainee, or helper, employed or working on the site of the work, all or part of the wages required by the contract, the contracting agency may, after written notice to the contractor, take such action as may be necessary to cause the suspension of any further payment, advance, or guarantee of funds until such violations have ceased.

3. Payrolls and basic records

a. Payrolls and basic records relating thereto shall be maintained by the contractor during the course of the work and preserved for a period of three years thereafter for all laborers and mechanics working at the site of the work. Such records shall contain the name, address, and social security number of each such worker, his or her correct classification, hourly rates of wages paid (including rates of contributions or costs anticipated for bona fide fringe benefits or cash equivalents thereof of the types described in section 1(b)(2)(B) of the Davis-Bacon Act), daily and weekly number of hours worked, deductions made and actual wages paid. Whenever the Secretary of Labor has found under 29 CFR 5.5(a)(1)(iv) that the wages of any laborer or mechanic include the amount of any costs reasonably anticipated in providing benefits under a plan or program described in section 1(b)(2)(B) of the Davis-

Bacon Act, the contractor shall maintain records which show that the commitment to provide such benefits is enforceable, that the plan or program is financially responsible, and that the plan or program has been communicated in writing to the laborers or mechanics affected, and records which show the costs anticipated or the actual cost incurred in providing such benefits. Contractors employing apprentices or trainees under approved programs shall maintain written evidence of the registration of apprenticeship programs and certification of trainee programs, the registration of the apprentices and trainees, and the ratios and wage rates prescribed in the applicable programs.

b.(1) The contractor shall submit weekly for each week in which any contract work is performed a copy of all payrolls to the contracting agency. The payrolls submitted shall set out accurately and completely all of the information required to be maintained under 29 CFR 5.5(a)(3)(i), except that full social security numbers and home addresses shall not be included on weekly transmittals. Instead the payrolls shall only need to include an individually identifying number for each employee (e.g., the last four digits of the employee's social security number). The required weekly payroll information may be submitted in any form desired. Optional Form WH-347 is available for this purpose from the Wage and Hour Division Web site at <http://www.dol.gov/esa/whd/forms/wh347instr.htm> or its successor site. The prime contractor is responsible for the submission of copies of payrolls by all subcontractors. Contractors and subcontractors shall maintain the full social security number and current address of each covered worker, and shall provide them upon request to the contracting agency for transmission to the State DOT, the FHWA or the Wage and Hour Division of the Department of Labor for purposes of an investigation or audit of compliance with prevailing wage requirements. It is not a violation of this section for a prime contractor to require a subcontractor to provide addresses and social security numbers to the prime contractor for its own records, without weekly submission to the contracting agency..

(2) Each payroll submitted shall be accompanied by a "Statement of Compliance," signed by the contractor or subcontractor or his or her agent who pays or supervises the payment of the persons employed under the contract and shall certify the following:

(i) That the payroll for the payroll period contains the information required to be provided under §5.5 (a)(3)(ii) of Regulations, 29 CFR part 5, the appropriate information is being maintained under §5.5 (a)(3)(i) of Regulations, 29 CFR part 5, and that such information is correct and complete;

(ii) That each laborer or mechanic (including each helper, apprentice, and trainee) employed on the contract during the payroll period has been paid the full weekly wages earned, without rebate, either directly or indirectly, and that no deductions have been made either directly or indirectly from the full wages earned, other than permissible deductions as set forth in Regulations, 29 CFR part 3;

(iii) That each laborer or mechanic has been paid not less than the applicable wage rates and fringe benefits or cash equivalents for the classification of work performed, as specified in the applicable wage determination incorporated into the contract.

(3) The weekly submission of a properly executed certification set forth on the reverse side of Optional Form WH-347 shall satisfy the requirement for submission of the "Statement of Compliance" required by paragraph 3.b.(2) of this section.

(4) The falsification of any of the above certifications may subject the contractor or subcontractor to civil or criminal prosecution under section 1001 of title 18 and section 231 of title 31 of the United States Code.

c. The contractor or subcontractor shall make the records required under paragraph 3.a. of this section available for inspection, copying, or transcription by authorized representatives of the contracting agency, the State DOT, the FHWA, or the Department of Labor, and shall permit such representatives to interview employees during working hours on the job. If the contractor or subcontractor fails to submit the required records or to make them available, the FHWA may, after written notice to the contractor, the contracting agency or the State DOT, take such action as may be necessary to cause the suspension of any further payment, advance, or guarantee of funds. Furthermore, failure to submit the required records upon request or to make such records available may be grounds for debarment action pursuant to 29 CFR 5.12.

4. Apprentices and trainees

a. Apprentices (programs of the USDOL).

Apprentices will be permitted to work at less than the predetermined rate for the work they performed when they are employed pursuant to and individually registered in a bona fide apprenticeship program registered with the U.S. Department of Labor, Employment and Training Administration, Office of Apprenticeship Training, Employer and Labor Services, or with a State Apprenticeship Agency recognized by the Office, or if a person is employed in his or her first 90 days of probationary employment as an apprentice in such an apprenticeship program, who is not individually registered in the program, but who has been certified by the Office of Apprenticeship Training, Employer and Labor Services or a State Apprenticeship Agency (where appropriate) to be eligible for probationary employment as an apprentice.

The allowable ratio of apprentices to journeymen on the job site in any craft classification shall not be greater than the ratio permitted to the contractor as to the entire work force under the registered program. Any worker listed on a payroll at an apprentice wage rate, who is not registered or otherwise employed as stated above, shall be paid not less than the applicable wage rate on the wage determination for the classification of work actually performed. In addition, any apprentice performing work on the job site in excess of the ratio permitted under the registered program shall be paid not less than the applicable wage rate on the wage determination for the work actually performed. Where a contractor is performing construction on a project in a locality other than that in which its program is registered, the ratios and wage rates (expressed in percentages of the journeyman's hourly rate) specified in the contractor's or subcontractor's registered program shall be observed.

Every apprentice must be paid at not less than the rate specified in the registered program for the apprentice's level of progress, expressed as a percentage of the journeymen hourly

rate specified in the applicable wage determination. Apprentices shall be paid fringe benefits in accordance with the provisions of the apprenticeship program. If the apprenticeship program does not specify fringe benefits, apprentices must be paid the full amount of fringe benefits listed on the wage determination for the applicable classification. If the Administrator determines that a different practice prevails for the applicable apprentice classification, fringes shall be paid in accordance with that determination.

In the event the Office of Apprenticeship Training, Employer and Labor Services, or a State Apprenticeship Agency recognized by the Office, withdraws approval of an apprenticeship program, the contractor will no longer be permitted to utilize apprentices at less than the applicable predetermined rate for the work performed until an acceptable program is approved.

b. Trainees (programs of the USDOL).

Except as provided in 29 CFR 5.16, trainees will not be permitted to work at less than the predetermined rate for the work performed unless they are employed pursuant to and individually registered in a program which has received prior approval, evidenced by formal certification by the U.S. Department of Labor, Employment and Training Administration.

The ratio of trainees to journeymen on the job site shall not be greater than permitted under the plan approved by the Employment and Training Administration.

Every trainee must be paid at not less than the rate specified in the approved program for the trainee's level of progress, expressed as a percentage of the journeyman hourly rate specified in the applicable wage determination. Trainees shall be paid fringe benefits in accordance with the provisions of the trainee program. If the trainee program does not mention fringe benefits, trainees shall be paid the full amount of fringe benefits listed on the wage determination unless the Administrator of the Wage and Hour Division determines that there is an apprenticeship program associated with the corresponding journeyman wage rate on the wage determination which provides for less than full fringe benefits for apprentices. Any employee listed on the payroll at a trainee rate who is not registered and participating in a training plan approved by the Employment and Training Administration shall be paid not less than the applicable wage rate on the wage determination for the classification of work actually performed. In addition, any trainee performing work on the job site in excess of the ratio permitted under the registered program shall be paid not less than the applicable wage rate on the wage determination for the work actually performed.

In the event the Employment and Training Administration withdraws approval of a training program, the contractor will no longer be permitted to utilize trainees at less than the applicable predetermined rate for the work performed until an acceptable program is approved.

c. Equal employment opportunity. The utilization of apprentices, trainees and journeymen under this part shall be in conformity with the equal employment opportunity requirements of Executive Order 11246, as amended, and 29 CFR part 30.

d. Apprentices and Trainees (programs of the U.S. DOT).

Apprentices and trainees working under apprenticeship and skill training programs which have been certified by the Secretary of Transportation as promoting EEO in connection with Federal-aid highway construction programs are not subject to the requirements of paragraph 4 of this Section IV. The straight time hourly wage rates for apprentices and trainees under such programs will be established by the particular programs. The ratio of apprentices and trainees to journeymen shall not be greater than permitted by the terms of the particular program.

5. Compliance with Copeland Act requirements. The contractor shall comply with the requirements of 29 CFR part 3, which are incorporated by reference in this contract.

6. Subcontracts. The contractor or subcontractor shall insert Form FHWA-1273 in any subcontracts and also require the subcontractors to include Form FHWA-1273 in any lower tier subcontracts. The prime contractor shall be responsible for the compliance by any subcontractor or lower tier subcontractor with all the contract clauses in 29 CFR 5.5.

7. Contract termination: debarment. A breach of the contract clauses in 29 CFR 5.5 may be grounds for termination of the contract, and for debarment as a contractor and a subcontractor as provided in 29 CFR 5.12.

8. Compliance with Davis-Bacon and Related Act requirements. All rulings and interpretations of the Davis-Bacon and Related Acts contained in 29 CFR parts 1, 3, and 5 are herein incorporated by reference in this contract.

9. Disputes concerning labor standards. Disputes arising out of the labor standards provisions of this contract shall not be subject to the general disputes clause of this contract. Such disputes shall be resolved in accordance with the procedures of the Department of Labor set forth in 29 CFR parts 5, 6, and 7. Disputes within the meaning of this clause include disputes between the contractor (or any of its subcontractors) and the contracting agency, the U.S. Department of Labor, or the employees or their representatives.

10. Certification of eligibility.

a. By entering into this contract, the contractor certifies that neither it (nor he or she) nor any person or firm who has an interest in the contractor's firm is a person or firm ineligible to be awarded Government contracts by virtue of section 3(a) of the Davis-Bacon Act or 29 CFR 5.12(a)(1).

b. No part of this contract shall be subcontracted to any person or firm ineligible for award of a Government contract by virtue of section 3(a) of the Davis-Bacon Act or 29 CFR 5.12(a)(1).

c. The penalty for making false statements is prescribed in the U.S. Criminal Code, 18 U.S.C. 1001.

V. CONTRACT WORK HOURS AND SAFETY STANDARDS ACT

The following clauses apply to any Federal-aid construction contract in an amount in excess of \$100,000 and subject to the overtime provisions of the Contract Work Hours and Safety Standards Act. These clauses shall be inserted in addition to the clauses required by 29 CFR 5.5(a) or 29 CFR 4.6. As used in this paragraph, the terms laborers and mechanics include watchmen and guards.

1. Overtime requirements. No contractor or subcontractor contracting for any part of the contract work which may require or involve the employment of laborers or mechanics shall require or permit any such laborer or mechanic in any workweek in which he or she is employed on such work to work in excess of forty hours in such workweek unless such laborer or mechanic receives compensation at a rate not less than one and one-half times the basic rate of pay for all hours worked in excess of forty hours in such workweek.

2. Violation; liability for unpaid wages; liquidated damages. In the event of any violation of the clause set forth in paragraph (1.) of this section, the contractor and any subcontractor responsible therefor shall be liable for the unpaid wages. In addition, such contractor and subcontractor shall be liable to the United States (in the case of work done under contract for the District of Columbia or a territory, to such District or to such territory), for liquidated damages. Such liquidated damages shall be computed with respect to each individual laborer or mechanic, including watchmen and guards, employed in violation of the clause set forth in paragraph (1.) of this section, in the sum of \$10 for each calendar day on which such individual was required or permitted to work in excess of the standard workweek of forty hours without payment of the overtime wages required by the clause set forth in paragraph (1.) of this section.

3. Withholding for unpaid wages and liquidated damages. The FHWA or the contracting agency shall upon its own action or upon written request of an authorized representative of the Department of Labor withhold or cause to be withheld, from any moneys payable on account of work performed by the contractor or subcontractor under any such contract or any other Federal contract with the same prime contractor, or any other federally-assisted contract subject to the Contract Work Hours and Safety Standards Act, which is held by the same prime contractor, such sums as may be determined to be necessary to satisfy any liabilities of such contractor or subcontractor for unpaid wages and liquidated damages as provided in the clause set forth in paragraph (2.) of this section.

4. Subcontracts. The contractor or subcontractor shall insert in any subcontracts the clauses set forth in paragraph (1.) through (4.) of this section and also a clause requiring the subcontractors to include these clauses in any lower tier subcontracts. The prime contractor shall be responsible for compliance by any subcontractor or lower tier subcontractor with the clauses set forth in paragraphs (1.) through (4.) of this section.

VI. SUBLETTING OR ASSIGNING THE CONTRACT

This provision is applicable to all Federal-aid construction contracts on the National Highway System.

1. The contractor shall perform with its own organization contract work amounting to not less than 30 percent (or a greater percentage if specified elsewhere in the contract) of the total original contract price, excluding any specialty items designated by the contracting agency. Specialty items may be performed by subcontract and the amount of any such specialty items performed may be deducted from the total original contract price before computing the amount of work required to be performed by the contractor's own organization (23 CFR 635.116).

a. The term "perform work with its own organization" refers to workers employed or leased by the prime contractor, and equipment owned or rented by the prime contractor, with or without operators. Such term does not include employees or equipment of a subcontractor or lower tier subcontractor, agents of the prime contractor, or any other assignees. The term may include payments for the costs of hiring leased employees from an employee leasing firm meeting all relevant Federal and State regulatory requirements. Leased employees may only be included in this term if the prime contractor meets all of the following conditions:

- (1) the prime contractor maintains control over the supervision of the day-to-day activities of the leased employees;
- (2) the prime contractor remains responsible for the quality of the work of the leased employees;
- (3) the prime contractor retains all power to accept or exclude individual employees from work on the project; and
- (4) the prime contractor remains ultimately responsible for the payment of predetermined minimum wages, the submission of payrolls, statements of compliance and all other Federal regulatory requirements.

b. "Specialty Items" shall be construed to be limited to work that requires highly specialized knowledge, abilities, or equipment not ordinarily available in the type of contracting organizations qualified and expected to bid or propose on the contract as a whole and in general are to be limited to minor components of the overall contract.

2. The contract amount upon which the requirements set forth in paragraph (1) of Section VI is computed includes the cost of material and manufactured products which are to be purchased or produced by the contractor under the contract provisions.

3. The contractor shall furnish (a) a competent superintendent or supervisor who is employed by the firm, has full authority to direct performance of the work in accordance with the contract requirements, and is in charge of all construction operations (regardless of who performs the work) and (b) such other of its own organizational resources (supervision, management, and engineering services) as the contracting officer determines is necessary to assure the performance of the contract.

4. No portion of the contract shall be sublet, assigned or otherwise disposed of except with the written consent of the contracting officer, or authorized representative, and such consent when given shall not be construed to relieve the contractor of any responsibility for the fulfillment of the contract. Written consent will be given only after the contracting agency has assured that each subcontract is

evidenced in writing and that it contains all pertinent provisions and requirements of the prime contract.

5. The 30% self-performance requirement of paragraph (1) is not applicable to design-build contracts; however, contracting agencies may establish their own self-performance requirements.

VII. SAFETY: ACCIDENT PREVENTION

This provision is applicable to all Federal-aid construction contracts and to all related subcontracts.

1. In the performance of this contract the contractor shall comply with all applicable Federal, State, and local laws governing safety, health, and sanitation (23 CFR 635). The contractor shall provide all safeguards, safety devices and protective equipment and take any other needed actions as it determines, or as the contracting officer may determine, to be reasonably necessary to protect the life and health of employees on the job and the safety of the public and to protect property in connection with the performance of the work covered by the contract.

2. It is a condition of this contract, and shall be made a condition of each subcontract, which the contractor enters into pursuant to this contract, that the contractor and any subcontractor shall not permit any employee, in performance of the contract, to work in surroundings or under conditions which are unsanitary, hazardous or dangerous to his/her health or safety, as determined under construction safety and health standards (29 CFR 1926) promulgated by the Secretary of Labor, in accordance with Section 107 of the Contract Work Hours and Safety Standards Act (40 U.S.C. 3704).

3. Pursuant to 29 CFR 1926.3, it is a condition of this contract that the Secretary of Labor or authorized representative thereof, shall have right of entry to any site of contract performance to inspect or investigate the matter of compliance with the construction safety and health standards and to carry out the duties of the Secretary under Section 107 of the Contract Work Hours and Safety Standards Act (40 U.S.C.3704).

VIII. FALSE STATEMENTS CONCERNING HIGHWAY PROJECTS

This provision is applicable to all Federal-aid construction contracts and to all related subcontracts.

In order to assure high quality and durable construction in conformity with approved plans and specifications and a high degree of reliability on statements and representations made by engineers, contractors, suppliers, and workers on Federal-aid highway projects, it is essential that all persons concerned with the project perform their functions as carefully, thoroughly, and honestly as possible. Willful falsification, distortion, or misrepresentation with respect to any facts related to the project is a violation of Federal law. To prevent any misunderstanding regarding the seriousness of these and similar acts, Form FHWA-1022 shall be posted on each Federal-aid highway project (23 CFR 635) in one or more places where it is readily available to all persons concerned with the project:

18 U.S.C. 1020 reads as follows:

"Whoever, being an officer, agent, or employee of the United States, or of any State or Territory, or whoever, whether a person, association, firm, or corporation, knowingly makes any false statement, false representation, or false report as to the character, quality, quantity, or cost of the material used or to be used, or the quantity or quality of the work performed or to be performed, or the cost thereof in connection with the submission of plans, maps, specifications, contracts, or costs of construction on any highway or related project submitted for approval to the Secretary of Transportation; or

Whoever knowingly makes any false statement, false representation, false report or false claim with respect to the character, quality, quantity, or cost of any work performed or to be performed, or materials furnished or to be furnished, in connection with the construction of any highway or related project approved by the Secretary of Transportation; or

Whoever knowingly makes any false statement or false representation as to material fact in any statement, certificate, or report submitted pursuant to provisions of the Federal-aid Roads Act approved July 1, 1916, (39 Stat. 355), as amended and supplemented;

Shall be fined under this title or imprisoned not more than 5 years or both."

IX. IMPLEMENTATION OF CLEAN AIR ACT AND FEDERAL WATER POLLUTION CONTROL ACT

This provision is applicable to all Federal-aid construction contracts and to all related subcontracts.

By submission of this bid/proposal or the execution of this contract, or subcontract, as appropriate, the bidder, proposer, Federal-aid construction contractor, or subcontractor, as appropriate, will be deemed to have stipulated as follows:

1. That any person who is or will be utilized in the performance of this contract is not prohibited from receiving an award due to a violation of Section 508 of the Clean Water Act or Section 306 of the Clean Air Act.

2. That the contractor agrees to include or cause to be included the requirements of paragraph (1) of this Section X in every subcontract, and further agrees to take such action as the contracting agency may direct as a means of enforcing such requirements.

X. CERTIFICATION REGARDING DEBARMENT, SUSPENSION, INELIGIBILITY AND VOLUNTARY EXCLUSION

This provision is applicable to all Federal-aid construction contracts, design-build contracts, subcontracts, lower-tier subcontracts, purchase orders, lease agreements, consultant contracts or any other covered transaction requiring FHWA approval or that is estimated to cost \$25,000 or more – as defined in 2 CFR Parts 180 and 1200.

1. Instructions for Certification – First Tier Participants:

a. By signing and submitting this proposal, the prospective first tier participant is providing the certification set out below.

b. The inability of a person to provide the certification set out below will not necessarily result in denial of participation in this

covered transaction. The prospective first tier participant shall submit an explanation of why it cannot provide the certification set out below. The certification or explanation will be considered in connection with the department or agency's determination whether to enter into this transaction. However, failure of the prospective first tier participant to furnish a certification or an explanation shall disqualify such a person from participation in this transaction.

c. The certification in this clause is a material representation of fact upon which reliance was placed when the contracting agency determined to enter into this transaction. If it is later determined that the prospective participant knowingly rendered an erroneous certification, in addition to other remedies available to the Federal Government, the contracting agency may terminate this transaction for cause of default.

d. The prospective first tier participant shall provide immediate written notice to the contracting agency to whom this proposal is submitted if any time the prospective first tier participant learns that its certification was erroneous when submitted or has become erroneous by reason of changed circumstances.

e. The terms "covered transaction," "debarred," "suspended," "ineligible," "participant," "person," "principal," and "voluntarily excluded," as used in this clause, are defined in 2 CFR Parts 180 and 1200. "First Tier Covered Transactions" refers to any covered transaction between a grantee or subgrantee of Federal funds and a participant (such as the prime or general contract). "Lower Tier Covered Transactions" refers to any covered transaction under a First Tier Covered Transaction (such as subcontracts). "First Tier Participant" refers to the participant who has entered into a covered transaction with a grantee or subgrantee of Federal funds (such as the prime or general contractor). "Lower Tier Participant" refers any participant who has entered into a covered transaction with a First Tier Participant or other Lower Tier Participants (such as subcontractors and suppliers).

f. The prospective first tier participant agrees by submitting this proposal that, should the proposed covered transaction be entered into, it shall not knowingly enter into any lower tier covered transaction with a person who is debarred, suspended, declared ineligible, or voluntarily excluded from participation in this covered transaction, unless authorized by the department or agency entering into this transaction.

g. The prospective first tier participant further agrees by submitting this proposal that it will include the clause titled "Certification Regarding Debarment, Suspension, Ineligibility and Voluntary Exclusion-Lower Tier Covered Transactions," provided by the department or contracting agency, entering into this covered transaction, without modification, in all lower tier covered transactions and in all solicitations for lower tier covered transactions exceeding the \$25,000 threshold.

h. A participant in a covered transaction may rely upon a certification of a prospective participant in a lower tier covered transaction that is not debarred, suspended, ineligible, or voluntarily excluded from the covered transaction, unless it knows that the certification is erroneous. A participant is responsible for ensuring that its principals are not suspended, debarred, or otherwise ineligible to participate in covered transactions. To verify the eligibility of its principals, as well as the eligibility of any lower tier prospective participants, each participant may, but is not required to, check the Excluded Parties List System website (<https://www.epls.gov/>), which is compiled by the General Services Administration.

i. Nothing contained in the foregoing shall be construed to require the establishment of a system of records in order to render in good faith the certification required by this clause. The knowledge and information of the prospective participant is not required to exceed that which is normally possessed by a prudent person in the ordinary course of business dealings.

j. Except for transactions authorized under paragraph (f) of these instructions, if a participant in a covered transaction knowingly enters into a lower tier covered transaction with a person who is suspended, debarred, ineligible, or voluntarily excluded from participation in this transaction, in addition to other remedies available to the Federal Government, the department or agency may terminate this transaction for cause or default.

2. Certification Regarding Debarment, Suspension, Ineligibility and Voluntary Exclusion – First Tier Participants:

a. The prospective first tier participant certifies to the best of its knowledge and belief, that it and its principals:

- (1) Are not presently debarred, suspended, proposed for debarment, declared ineligible, or voluntarily excluded from participating in covered transactions by any Federal department or agency;
- (2) Have not within a three-year period preceding this proposal been convicted of or had a civil judgment rendered against them for commission of fraud or a criminal offense in connection with obtaining, attempting to obtain, or performing a public (Federal, State or local) transaction or contract under a public transaction; violation of Federal or State antitrust statutes or commission of embezzlement, theft, forgery, bribery, falsification or destruction of records, making false statements, or receiving stolen property;
- (3) Are not presently indicted for or otherwise criminally or civilly charged by a governmental entity (Federal, State or local) with commission of any of the offenses enumerated in paragraph (a)(2) of this certification; and
- (4) Have not within a three-year period preceding this application/proposal had one or more public transactions (Federal, State or local) terminated for cause or default.

b. Where the prospective participant is unable to certify to any of the statements in this certification, such prospective participant shall attach an explanation to this proposal.

2. Instructions for Certification - Lower Tier Participants:

(Applicable to all subcontracts, purchase orders and other lower tier transactions requiring prior FHWA approval or estimated to cost \$25,000 or more - 2 CFR Parts 180 and 1200)

a. By signing and submitting this proposal, the prospective lower tier is providing the certification set out below.

b. The certification in this clause is a material representation of fact upon which reliance was placed when this transaction was entered into. If it is later determined that the prospective lower tier participant knowingly rendered an erroneous certification, in addition to other remedies available to the Federal Government, the department, or agency with which

this transaction originated may pursue available remedies, including suspension and/or debarment.

c. The prospective lower tier participant shall provide immediate written notice to the person to which this proposal is submitted if at any time the prospective lower tier participant learns that its certification was erroneous by reason of changed circumstances.

d. The terms "covered transaction," "debarred," "suspended," "ineligible," "participant," "person," "principal," and "voluntarily excluded," as used in this clause, are defined in 2 CFR Parts 180 and 1200. You may contact the person to which this proposal is submitted for assistance in obtaining a copy of those regulations. "First Tier Covered Transactions" refers to any covered transaction between a grantee or subgrantee of Federal funds and a participant (such as the prime or general contract). "Lower Tier Covered Transactions" refers to any covered transaction under a First Tier Covered Transaction (such as subcontracts). "First Tier Participant" refers to the participant who has entered into a covered transaction with a grantee or subgrantee of Federal funds (such as the prime or general contractor). "Lower Tier Participant" refers any participant who has entered into a covered transaction with a First Tier Participant or other Lower Tier Participants (such as subcontractors and suppliers).

e. The prospective lower tier participant agrees by submitting this proposal that, should the proposed covered transaction be entered into, it shall not knowingly enter into any lower tier covered transaction with a person who is debarred, suspended, declared ineligible, or voluntarily excluded from participation in this covered transaction, unless authorized by the department or agency with which this transaction originated.

f. The prospective lower tier participant further agrees by submitting this proposal that it will include this clause titled "Certification Regarding Debarment, Suspension, Ineligibility and Voluntary Exclusion-Lower Tier Covered Transaction," without modification, in all lower tier covered transactions and in all solicitations for lower tier covered transactions exceeding the \$25,000 threshold.

g. A participant in a covered transaction may rely upon a certification of a prospective participant in a lower tier covered transaction that is not debarred, suspended, ineligible, or voluntarily excluded from the covered transaction, unless it knows that the certification is erroneous. A participant is responsible for ensuring that its principals are not suspended, debarred, or otherwise ineligible to participate in covered transactions. To verify the eligibility of its principals, as well as the eligibility of any lower tier prospective participants, each participant may, but is not required to, check the Excluded Parties List System website (<https://www.epls.gov/>), which is compiled by the General Services Administration.

h. Nothing contained in the foregoing shall be construed to require establishment of a system of records in order to render in good faith the certification required by this clause. The knowledge and information of participant is not required to exceed that which is normally possessed by a prudent person in the ordinary course of business dealings.

i. Except for transactions authorized under paragraph e of these instructions, if a participant in a covered transaction knowingly enters into a lower tier covered transaction with a person who is suspended, debarred, ineligible, or voluntarily excluded from participation in this transaction, in addition to other remedies available to the Federal Government, the

department or agency with which this transaction originated may pursue available remedies, including suspension and/or debarment.

* * * * *

Certification Regarding Debarment, Suspension, Ineligibility and Voluntary Exclusion--Lower Tier Participants:

1. The prospective lower tier participant certifies, by submission of this proposal, that neither it nor its principals is presently debarred, suspended, proposed for debarment, declared ineligible, or voluntarily excluded from participating in covered transactions by any Federal department or agency.

2. Where the prospective lower tier participant is unable to certify to any of the statements in this certification, such prospective participant shall attach an explanation to this proposal.

* * * * *

XI. CERTIFICATION REGARDING USE OF CONTRACT FUNDS FOR LOBBYING

This provision is applicable to all Federal-aid construction contracts and to all related subcontracts which exceed \$100,000 (49 CFR 20).

1. The prospective participant certifies, by signing and submitting this bid or proposal, to the best of his or her knowledge and belief, that:

a. No Federal appropriated funds have been paid or will be paid, by or on behalf of the undersigned, to any person for influencing or attempting to influence an officer or employee of any Federal agency, a Member of Congress, an officer or employee of Congress, or an employee of a Member of Congress in connection with the awarding of any Federal contract, the making of any Federal grant, the making of any Federal loan, the entering into of any cooperative agreement, and the extension, continuation, renewal, amendment, or modification of any Federal contract, grant, loan, or cooperative agreement.

b. If any funds other than Federal appropriated funds have been paid or will be paid to any person for influencing or attempting to influence an officer or employee of any Federal agency, a Member of Congress, an officer or employee of Congress, or an employee of a Member of Congress in connection with this Federal contract, grant, loan, or cooperative agreement, the undersigned shall complete and submit Standard Form-LLL, "Disclosure Form to Report Lobbying," in accordance with its instructions.

2. This certification is a material representation of fact upon which reliance was placed when this transaction was made or entered into. Submission of this certification is a prerequisite for making or entering into this transaction imposed by 31 U.S.C. 1352. Any person who fails to file the required certification shall be subject to a civil penalty of not less than \$10,000 and not more than \$100,000 for each such failure.

3. The prospective participant also agrees by submitting its bid or proposal that the participant shall require that the language of this certification be included in all lower tier subcontracts, which exceed \$100,000 and that all such recipients shall certify and disclose accordingly.

**ATTACHMENT A - EMPLOYMENT AND MATERIALS
PREFERENCE FOR APPALACHIAN DEVELOPMENT
HIGHWAY SYSTEM OR APPALACHIAN LOCAL ACCESS
ROAD CONTRACTS**

This provision is applicable to all Federal-aid projects funded under the Appalachian Regional Development Act of 1965.

1. During the performance of this contract, the contractor undertaking to do work which is, or reasonably may be, done as on-site work, shall give preference to qualified persons who regularly reside in the labor area as designated by the DOL wherein the contract work is situated, or the subregion, or the Appalachian counties of the State wherein the contract work is situated, except:

a. To the extent that qualified persons regularly residing in the area are not available.

b. For the reasonable needs of the contractor to employ supervisory or specially experienced personnel necessary to assure an efficient execution of the contract work.

c. For the obligation of the contractor to offer employment to present or former employees as the result of a lawful collective bargaining contract, provided that the number of nonresident persons employed under this subparagraph (1c) shall not exceed 20 percent of the total number of employees employed by the contractor on the contract work, except as provided in subparagraph (4) below.

2. The contractor shall place a job order with the State Employment Service indicating (a) the classifications of the laborers, mechanics and other employees required to perform the contract work, (b) the number of employees required in each classification, (c) the date on which the participant estimates such employees will be required, and (d) any other pertinent information required by the State Employment Service to complete the job order form. The job order may be placed with the State Employment Service in writing or by telephone. If during the course of the contract work, the information submitted by the contractor in the original job order is substantially modified, the participant shall promptly notify the State Employment Service.

3. The contractor shall give full consideration to all qualified job applicants referred to him by the State Employment Service. The contractor is not required to grant employment to any job applicants who, in his opinion, are not qualified to perform the classification of work required.

4. If, within one week following the placing of a job order by the contractor with the State Employment Service, the State Employment Service is unable to refer any qualified job applicants to the contractor, or less than the number requested, the State Employment Service will forward a certificate to the contractor indicating the unavailability of applicants. Such certificate shall be made a part of the contractor's permanent project records. Upon receipt of this certificate, the contractor may employ persons who do not normally reside in the labor area to fill positions covered by the certificate, notwithstanding the provisions of subparagraph (1c) above.

5. The provisions of 23 CFR 633.207(e) allow the contracting agency to provide a contractual preference for the use of mineral resource materials native to the Appalachian region.

6. The contractor shall include the provisions of Sections 1 through 4 of this Attachment A in every subcontract for work which is, or reasonably may be, done as on-site work.

**KENTUCKY TRANSPORTATION CABINET
DEPARTMENT OF HIGHWAYS**

**EMPLOYMENT REQUIREMENTS
RELATING TO
NONDISCRIMINATION OF EMPLOYEES
(APPLICABLE TO FEDERAL-AID SYSTEM CONTRACTS)**

**AN ACT OF THE KENTUCKY GENERAL ASSEMBLY
TO PREVENT DISCRIMINATION IN EMPLOYMENT**

**KRS CHAPTER 344
EFFECTIVE JUNE 16, 1972**

The contract on this project, in accordance with KRS Chapter 344, provides that during the performance of this contract, the contractor agrees as follows:

4. The contractor will send to each labor union or representative of workers with which he has a collective bargaining agreement or other contract or understanding, a notice to be provided advising the said labor union or workers' representative of the contractor's commitments under this section, and shall post copies of the notice in conspicuous places available to employees and applicants for employment. The contractor will take such action with respect to any subcontract or purchase order as the administering agency may direct as a means of enforcing such provisions, including sanctions for non-compliance.

Revised: January 25, 2017

1. The contractor shall not fail or refuse to hire, or shall not discharge any individual, or otherwise discriminate against an individual with respect to his compensation, terms, conditions, or privileges of employment, because of such individual's race, color, religion, national origin, sex, disability or age (forty and above); or limit, segregate, or classify his employees in any way which would deprive or tend to deprive an individual of employment opportunities or otherwise adversely affect his status as an employee, because of such individual's race, color, religion, national origin, sex, disability or age forty (40) and over. The contractor agrees to post in conspicuous places, available to employees and applicants for employment, notices to be provided setting forth the provisions of this nondiscrimination clause.

2. The contractor shall not print or publish or cause to be printed or published a notice or advertisement relating to employment by such an employer or membership in or any classification or referral for employment by the employment agency, indicating any preference, limitation, specification, or discrimination, based on race, color, religion, national origin, sex, or age forty (40) and over, or because the person is a qualified individual with a disability, except that such a notice or advertisement may indicate a preference, limitation, or specification based on religion, national origin, sex, or age forty (40) and over, or because the person is a qualified individual with a disability, when religion, national origin, sex, or age forty (40) and over, or because the person is a qualified individual with a disability, is a bona fide occupational qualification for employment.

3. If the contractor is in control of apprenticeship or other training or retraining, including on-the-job training programs, he shall not discriminate against an individual because of his race, color, religion, national origin, sex, disability or age forty (40) and over, in admission to, or employment in any program established to provide apprenticeship or other training.

Standard Title VI/Non-Discrimination Assurances

During the performance of this contract, the contractor, for itself, its assignees, and successors in interest (hereinafter referred to as the "contractor") agrees as follows:

1. **Compliance with Regulations:** The contractor (hereinafter includes consultants) will comply with the Acts and the Regulations relative to Non-discrimination in Federally-assisted programs of the U.S. Department of Transportation, **Federal Highway Administration**, as they may be amended from time to time, which are herein incorporated by reference and made a part of this contract.
2. **Non-discrimination:** The contractor, with regard to the work performed by it during the contract, will not discriminate on the grounds of race, color, or national origin in the selection and retention of subcontractors, including procurements of materials and leases of equipment. The contractor will not participate directly or indirectly in the discrimination prohibited by the Acts and the Regulations, including employment practices when the contract covers any activity, project, or program set forth in Appendix B of 49 CFR Part 21.
3. **Solicitations for Subcontracts, Including Procurements of Materials and Equipment:** In all solicitations, either by competitive bidding, or negotiation made by the contractor for work to be performed under a subcontract, including procurements of materials, or leases of equipment, each potential subcontractor or supplier will be notified by the contractor of the contractor's obligations under this contract and the Acts and the Regulations relative to Non-discrimination on the grounds of race, color, or national origin.
4. **Information and Reports:** The contractor will provide all information and reports required by the Acts, the Regulations, and directives issued pursuant thereto and will permit access to its books, records, accounts, other sources of information, and its facilities as may be determined by the Recipient or the **Federal Highway Administration** to be pertinent to ascertain compliance with such Acts, Regulations, and instructions. Where any information required of a contractor is in the exclusive possession of another who fails or refuses to furnish the information, the contractor will so certify to the Recipient or the **Federal Highway Administration**, as appropriate, and will set forth what efforts it has made to obtain the information.
5. **Sanctions for Noncompliance:** In the event of a contractor's noncompliance with the Non-discrimination provisions of this contract, the Recipient will impose such contract sanctions as it or the **Federal Highway Administration** may determine to be appropriate, including, but not limited to:
 - a. withholding payments to the contractor under the contract until the contractor complies; and/or
 - b. cancelling, terminating, or suspending a contract, in whole or in part.
6. **Incorporation of Provisions:** The contractor will include the provisions of paragraphs one through six in every subcontract, including procurements of materials and leases of equipment, unless exempt by the Acts, the Regulations and directives issued pursuant thereto. The contractor will take action with respect to any subcontract or procurement as the Recipient or the **Federal Highway Administration** may direct as a means of enforcing such provisions including sanctions for noncompliance. Provided, that if the contractor becomes involved in, or is threatened with litigation by a subcontractor, or supplier because of such direction, the contractor may request the Recipient to enter into any litigation to protect the interests of the Recipient. In addition, the contractor may request the United States to enter into the litigation to protect the interests of the United States.

Standard Title VI/Non-Discrimination Statutes and Authorities

During the performance of this contract, the contractor, for itself, its assignees, and successors in interest (hereinafter referred to as the “contractor”) agrees to comply with the following non-discrimination statutes and authorities; including but not limited to:

- Title VI of the Civil Rights Act of 1964 (42 U.S.C. § 2000d *et seq.*, 78 stat. 252), (prohibits discrimination on the basis of race, color, national origin); and 49 CFR Part 21;
- The Uniform Relocation Assistance and Real Property Acquisition Policies Act of 1970, (42 U.S.C. § 4601), (prohibits unfair treatment of persons displaced or whose property has been acquired because of Federal or Federal-aid programs and projects);
- Federal-Aid Highway Act of 1973, (23 U.S.C. § 324 *et seq.*), (prohibits discrimination on the basis of sex);
- Section 504 of the Rehabilitation Act of 1973, (29 U.S.C. § 794 *et seq.*), as amended, (prohibits discrimination on the basis of disability); and 49 CFR Part 27;
- The Age Discrimination Act of 1975, as amended, (42 U.S.C. § 6101 *et seq.*), (prohibits discrimination on the basis of age);
- Airport and Airway Improvement Act of 1982, (49 USC § 471, Section 47123), as amended, (prohibits discrimination based on race, creed, color, national origin, or sex);
- The Civil Rights Restoration Act of 1987, (PL 100-209), (Broadened the scope, coverage and applicability of Title VI of the Civil Rights Act of 1964, The Age Discrimination Act of 1975 and Section 504 of the Rehabilitation Act of 1973, by expanding the definition of the terms “programs or activities” to include all of the programs or activities of the Federal-aid recipients, sub-recipients and contractors, whether such programs or activities are Federally funded or not);
- Titles II and III of the Americans with Disabilities Act, which prohibit discrimination on the basis of disability in the operation of public entities, public and private transportation systems, places of public accommodation, and certain testing entities (42 U.S.C. §§ 12131 -- 12189) as implemented by Department of Transportation regulations at 49 C.F.R. parts 37 and 38;
- The Federal Aviation Administration’s Non-discrimination statute (49 U.S.C. § 47123) (prohibits discrimination on the basis of race, color, national origin, and sex);
- Executive Order 12898, Federal Actions to Address Environmental Justice in Minority Populations and Low-Income Populations, which ensures non-discrimination against minority populations by discouraging programs, policies, and activities with disproportionately high and adverse human health or environmental effects on minority and low-income populations;
- Executive Order 13166, Improving Access to Services for Persons with Limited English Proficiency, and resulting agency guidance, national origin discrimination includes discrimination because of limited English proficiency (LEP). To ensure compliance with Title VI, you must take reasonable steps to ensure that LEP persons have meaningful access to your programs (70 Fed. Reg. at 74087 to 74100);
- Title IX of the Education Amendments of 1972, as amended, which prohibits you from discriminating because of sex in education programs or activities (20 U.S.C. 1681 *et seq.*)

EXECUTIVE BRANCH CODE OF ETHICS

In the 1992 regular legislative session, the General Assembly passed and Governor Brereton Jones signed Senate Bill 63 (codified as KRS 11A), the Executive Branch Code of Ethics, which states, in part:

KRS 11A.040 (7) provides:

No present or former public servant shall, within six (6) months following termination of his office or employment, accept employment, compensation, or other economic benefit from any person or business that contracts or does business with, or is regulated by, the state in matters in which he was directly involved during the last thirty-six (36) months of his tenure. This provision shall not prohibit an individual from returning to the same business, firm, occupation, or profession in which he was involved prior to taking office or beginning his term of employment, or for which he received, prior to his state employment, a professional degree or license, provided that, for a period of six (6) months, he personally refrains from working on any matter in which he was directly involved during the last thirty-six (36) months of his tenure in state government. This subsection shall not prohibit the performance of ministerial functions, including but not limited to filing tax returns, filing applications for permits or licenses, or filing incorporation papers, nor shall it prohibit the former officer or public servant from receiving public funds disbursed through entitlement programs.

KRS 11A.040 (9) states:

A former public servant shall not represent a person or business before a state agency in a matter in which the former public servant was directly involved during the last thirty-six (36) months of his tenure, for a period of one (1) year after the latter of:

- a) The date of leaving office or termination of employment; or
- b) The date the term of office expires to which the public servant was elected.

This law is intended to promote public confidence in the integrity of state government and to declare as public policy the idea that state employees should view their work as a public trust and not as a way to obtain private benefits.

If you have worked for the executive branch of state government within the past six months, you may be subject to the law's prohibitions. The law's applicability may be different if you hold elected office or are contemplating representation of another before a state agency.

Also, if you are affiliated with a firm which does business with the state and which employs former state executive-branch employees, you should be aware that the law may apply to them.

In case of doubt, the law permits you to request an advisory opinion from the Executive Branch Ethics Commission, 3 Fountain Place, Frankfort, Kentucky 40601; telephone (502) 564-7954.

Revised: January 27, 2017

"General Decision Number: KY20210038 10/29/2021

Superseded General Decision Number: KY20200038

State: Kentucky

Construction Type: Highway

Counties: Anderson, Bath, Bourbon, Boyd, Boyle, Bracken, Breckinridge, Bullitt, Carroll, Carter, Clark, Elliott, Fayette, Fleming, Franklin, Gallatin, Grant, Grayson, Greenup, Hardin, Harrison, Henry, Jefferson, Jessamine, Larue, Lewis, Madison, Marion, Mason, Meade, Mercer, Montgomery, Nelson, Nicholas, Oldham, Owen, Robertson, Rowan, Scott, Shelby, Spencer, Trimble, Washington and Woodford Counties in Kentucky.

HIGHWAY CONSTRUCTION PROJECTS (excluding tunnels, building structures in rest area projects & railroad construction; bascule, suspension & spandrel arch bridges designed for commercial navigation, bridges involving marine construction; and other major bridges).

Note: Under Executive Order (EO) 13658, an hourly minimum wage of \$10.95 for calendar year 2021 applies to all contracts subject to the Davis-Bacon Act for which the contract is awarded (and any solicitation was issued) on or after January 1, 2015. If this contract is covered by the EO, the contractor must pay all workers in any classification listed on this wage determination at least \$10.95 per hour (or the applicable wage rate listed on this wage determination, if it is higher) for all hours spent performing on the contract in calendar year 2021. If this contract is covered by the EO and a classification considered necessary for performance of work on the contract does not appear on this wage determination, the contractor must pay workers in that classification at least the wage rate determined through the conformance process set forth in 29 CFR 5.5(a)(1)(ii) (or the EO minimum wage rate, if it is higher than the conformed wage rate). The EO minimum wage rate will be adjusted annually. Please note that this EO applies to the above-mentioned types of contracts entered into by the federal government that are subject to the Davis-Bacon Act itself, but it does not apply to contracts subject only to the Davis-Bacon Related Acts, including those set forth at 29 CFR 5.1(a)(2)-(60). Additional information on contractor requirements and worker protections under the EO is available at www.dol.gov/whd/govcontracts.

Modification Number	Publication Date
0	01/01/2021
1	03/05/2021
2	10/29/2021

* BRIN0004-003 06/01/2021

BRECKENRIDGE COUNTY

	Rates	Fringes
BRICKLAYER.....	\$ 29.57	15.10

* BRKY0001-005 06/01/2021

BULLITT, CARROLL, GRAYSON, HARDIN, HENRY, JEFFERSON, LARUE,
MARION, MEADE, NELSON, OLDHAM, SHELBY, SPENCER, & TRIMBLE
COUNTIES:

	Rates	Fringes
BRICKLAYER.....	\$ 29.57	15.10

* BRKY0002-006 06/01/2021		

BRACKEN, GALLATIN, GRANT, MASON & ROBERTSON COUNTIES:

	Rates	Fringes
BRICKLAYER.....	\$ 30.87	15.87

* BRKY0007-004 06/01/2021		

BOYD, CARTER, ELLIOT, FLEMING, GREENUP, LEWIS & ROWAN COUNTIES:

	Rates	Fringes
BRICKLAYER.....	\$ 32.03	20.05

* BRKY0017-004 06/01/2021		

ANDERSON, BATH, BOURBON, BOYLE, CLARK, FAYETTE, FRANKLIN,
HARRISON, JESSAMINE, MADISON, MERCER, MONTGOMERY, NICHOLAS,
OWEN, SCOTT, WASHINGTON & WOODFORD COUNTIES:

	Rates	Fringes
BRICKLAYER.....	\$ 30.87	15.87

CARP0064-001 04/01/2020		

	Rates	Fringes
CARPENTER.....	\$ 29.81	19.96
Diver.....	\$ 45.09	19.96
PILEDRIVERMAN.....	\$ 30.06	19.96

ELEC0212-008 06/01/2020		

BRACKEN, GALLATIN and GRANT COUNTIES

	Rates	Fringes
ELECTRICIAN.....	\$ 31.30	19.72

ELEC0212-014 11/25/2019		

BRACKEN, GALLATIN & GRANT COUNTIES:

	Rates	Fringes
Sound & Communication Technician.....	\$ 24.35	12.09

ELEC0317-012 06/01/2020		

BOYD, CARTER, ELLIOT & ROWAN COUNTIES:

	Rates	Fringes
ELECTRICIAN (Wiremen).....	\$ 35.10	26.22

ELEC0369-007 05/26/2020		

ANDERSON, BATH, BOURBON, BOYLE, BRECKINRIDGE, BULLITT, CARROLL, CLARK, FAYETTE, FRAONKLIN, GRAYSON, HARDIN, HARRISON, HENRY, JEFFERSON, JESSAMINE, LARUE, MADISON, MARION, MEADE, MERCER, MONTGOMERY, NELSON, NICHOLAS, OLDHAM, OWEN, ROBERTSON, SCOTT, SHELBY, SPENCER, TRIMBLE, WASHINGTON, & WOODFORD COUNTIES:

	Rates	Fringes
ELECTRICIAN.....	\$ 33.21	17.85

ELEC0575-002 11/30/2020		

FLEMING, GREENUP, LEWIS & MASON COUNTIES:

	Rates	Fringes
ELECTRICIAN.....	\$ 33.75	19.22

* ENGI0181-018 07/01/2021		

	Rates	Fringes
POWER EQUIPMENT OPERATOR		
GROUP 1.....	\$ 34.80	17.85
GROUP 2.....	\$ 31.94	17.85
GROUP 3.....	\$ 32.39	17.85
GROUP 4.....	\$ 31.62	17.85

OPERATING ENGINEER CLASSIFICATIONS

GROUP 1 - A-Frame Winch Truck; Auto Patrol; Backfiller; Batcher Plant; Bituminous Paver; Bituminous Transfer Machine; Boom Cat; Bulldozer; Mechanic; Cableway; Carry-All Scoop; Carry Deck Crane; Central Compressor Plant; Cherry Picker; Clamshell; Concrete Mixer (21 cu. ft. or Over); Concrete Paver; Truck-Mounted Concrete Pump; Core Drill; Crane; Crusher Plant; Derrick; Derrick Boat; Ditching & Trenching Machine; Dragline; Dredge Operator; Dredge Engineer; Elevating Grader & Loaders; Grade-All; Gurries; Heavy Equipment Robotics Operator/Mechanic; High Lift; Hoe-Type Machine; Hoist (Two or More Drums); Hoisting Engine (Two or More Drums); Horizontal Directional Drill Operator; Hydrocrane; Hyster; KeCal Loader; LeTourneau; Locomotive; Mechanic; Mechanically Operated Laser Screed; Mechanic Welder; Mucking Machine; Motor Scraper; Orangepeel Bucket; Overhead Crane; Piledriver; Power Blade; Pumpcrete; Push Dozer; Rock Spreader, attached to equipment; Rotary Drill; Roller (Bituminous); Rough Terrain Crane; Scarifier; Scoopmobile; Shovel; Side Boom; Subgrader; Tailboom; Telescoping Type Forklift; Tow or Push Boat; Tower Crane (French, German & other types); Tractor Shovel; Truck Crane; Tunnel Mining Machines, including Moles, Shields or similar types of Tunnel Mining Equipment

GROUP 2 - Air Compressor (Over 900 cu. ft. per min.); Bituminous Mixer; Boom Type Tamping Machine; Bull Float; Concrete Mixer (Under 21 cu. ft.); Dredge Engineer; Electric Vibrator; Compactor/Self-Propelled Compactor;

Elevator (One Drum or Buck Hoist); Elevator (When used to Hoist Building Material); Finish Machine; Firemen & Hoist (One Drum); Flexplane; Forklift (Regardless of Lift Height); Form Grader; Joint Sealing Machine; Outboard Motor Boat; Power Sweeper (Riding Type); Roller (Rock); Ross Carrier; Skid Mounted or Trailer Mounted Concrete Pump; Skid Steer Machine with all Attachments; Switchman or Brakeman; Throttle Valve Person; Tractair & Road Widening Trencher; Tractor (50 H.P. or Over); Truck Crane Oiler; Tugger; Welding Machine; Well Points; & Whirley Oiler

GROUP 3 - All Off Road Material Handling Equipment, including Articulating Dump Trucks; Greaser on Grease Facilities servicing Heavy Equipment

GROUP 4 - Bituminous Distributor; Burlap & Curing Machine; Cement Gun; Concrete Saw; Conveyor; Deckhand Oiler; Grout Pump; Hydraulic Post Driver; Hydro Seeder; Mud Jack; Oiler; Paving Joint Machine; Power Form Handling Equipment; Pump; Roller (Earth); Steerman; Tamping Machine; Tractor (Under 50 H.P.); & Vibrator

CRANES - with booms 150 ft. & Over (Including JIB), and where the length of the boom in combination with the length of the piling leads equals or exceeds 150 ft. - \$1.00 over Group 1 rate

EMPLOYEES ASSIGNED TO WORK BELOW GROUND LEVEL ARE TO BE PAID 10% ABOVE BASIC WAGE RATE. THIS DOES NOT APPLY TO OPEN CUT WORK.

* IRON0044-009 06/01/2021

BRACKEN, GALLATIN, GRANT, HARRISON, ROBERTSON, BOURBON (Northern third, including Townships of Jackson, Millersburg, Ruddel Mills & Shawhan); CARROLL (Eastern third, including the Township of Ghent); FLEMING (Western part, excluding Townships of Beechburg, Colfax, Elizaville, Flemingsburg, Flemingsburg Junction, Foxport, Grange City, Hillsboro, Hilltop, Mount Carmel, Muses Mills, Nepton, Pecksridge, Plummers Landing, Plummers Mill, Poplar Plains, Ringos Mills, Tilton & Wallingford); MASON (Western two-thirds, including Townships of Dover, Lewisburg, Mays Lick, Maysville, Minerva, Moranburg, Murphysville, Ripley, Sardis, Shannon, South Ripley & Washington); NICHOLAS (Townships of Barefoot, Barterville, Carlisle, Ellisville, Headquarters, Henryville, Morningglory, Myers & Oakland Mills); OWEN (Townships of Beechwood, Bromley, Fairbanks, Holbrook, Jonesville, Long Ridge, Lusby's Mill, New, New Columbus, New Liberty, Owenton, Poplar Grove, Rockdale, Sanders, Teresita & Wheatley); SCOTT (Northern two-thirds, including Townships of Biddle, Davis, Delaplain, Elmville, Longlick, Muddy Ford, Oxford, Rogers Gap, Sadieville, Skinnersburg & Stonewall)

	Rates	Fringes
IRONWORKER		
Fence Erector.....	\$ 29.75	21.60
Structural.....	\$ 31.32	21.60

* IRON0070-006 06/01/2021

ANDERSON, BOYLE, BRECKINRIDGE, BULLITT, FAYETTE, FRANKLIN,
GRAYSON, HARDIN, HENRY, JEFFERSON, JESSAMINE, LARUE, MADISON,
MARION, MEADE, MERCER, NELSON, OLDHAM, SHELBY, SPENCER,
TRIMBLE, WASHINGTON & WOODFORD
BOURBON (Southern two-thirds, including Townships of Austerlity,
Centerville, Clintonville, Elizabeth, Hutchison, Littlerock,
North Middletown & Paris);
CARROLL (Western two-thirds, including Townships of Carrollton,
Easterday, English, Locust, Louis, Prestonville & Worthville);
CLARK (Western two-thirds, including Townships of Becknerville,
Flanagan, Ford, Pine Grove, Winchester & Wyandotte);
OWEN (Eastern eighth, including Townships of Glenmary, Gratz,
Monterey, Perry Park & Tacketts Mill);
SCOTT (Southern third, including Townships of Georgetown, Great
Crossing, Newtown, Stampaling Ground & Woodlake);

	Rates	Fringes
IRONWORKER.....	\$ 31.09	23.75

* IRON0769-007 06/01/2021

BATH, BOYD, CARTER, ELLIOTT, GREENUP, LEWIS, MONTGOMERY & ROWAN
CLARK (Eastern third, including townships of Bloomingdale,
Hunt, Indian Fields, Kiddville, Loglick, Rightangele & Thomson);
FLEMING (Townships of Beechburg, Colfax, Elizaville,
Flemingsburg, Flemingsburg Junction, Foxport, Grange City,
Hillsboro, Hilltop, Mount Carmel, Muses Mills, Nepton,
Pecksridge, Plummers Landing, Plummers Mill, Poplar Plains,
Ringos Mills, Tilton & Wallingford);
MASON (Eastern third, including Townships of Helena, Marshall,
Orangeburg, Plumville & Springdale);
NICHOLAS (Eastern eighth, including the Township of Moorefield
Sprout)

	Rates	Fringes
IRONWORKER		
ZONE 1.....	\$ 33.00	27.29
ZONE 2.....	\$ 33.40	27.29
ZONE 3.....	\$ 35.00	27.29

ZONE 1 - (no base rate increase) Up to 10 mile radius of
Union Hall, 1643 Greenup Ave, Ashland, KY.

ZONE 2 - (add \$0.40 per hour to base rate) 10 to 50 mile
radius of Union Hall, 1643 Greenup Ave, Ashland, KY.

ZONE 3 - (add \$2.00 per hour to base rate) 50 mile radius &
over of Union Hall, 1643 Greenup Ave, Ashland, KY.

* LAB00189-003 07/01/2021

BATH, BOURBON, BOYD, BOYLE, BRACKEN, CARTER, CLARK, ELLIOTT,
FAYETTE, FLEMING, FRANKLIN, GALLATIN, GRANT, GREENUP, HARRISON,
JESSAMINE, LEWIS, MADISON, MASON, MERCER, MONTGOMERY, NICHOLAS,
OWEN, ROBERTSON, ROWAN, SCOTT, & WOOLFORD COUNTIES

	Rates	Fringes
--	-------	---------

Laborers:

GROUP 1.....	\$ 23.51	16.22
GROUP 2.....	\$ 23.76	16.22
GROUP 3.....	\$ 23.81	16.22
GROUP 4.....	\$ 24.41	16.22

LABORERS CLASSIFICATIONS

GROUP 1 - Aging & Curing of Concrete; Asbestos Abatement Worker; Asphalt Plant; Asphalt; Batch Truck Dump; Carpenter Tender; Cement Mason Tender; Cleaning of Machines; Concrete; Demolition; Dredging; Environmental - Nuclear, Radiation, Toxic & Hazardous Waste - Level D; Flagger; Grade Checker; Hand Digging & Hand Back Filling; Highway Marker Placer; Landscaping, Mesh Handler & Placer; Puddler; Railroad; Rip-rap & Grouter; Right-of-Way; Sign, Guard Rail & Fence Installer; Signal Person; Sound Barrier Installer; Storm & Sanitary Sewer; Swamper; Truck Spotter & Dumper; Wrecking of Concrete Forms; General Cleanup

GROUP 2 - Batter Board Man (Sanitary & Storm Sewer); Brickmason Tender; Mortar Mixer Operator; Scaffold Builder; Burner & Welder; Bushhammer; Chain Saw Operator; Concrete Saw Operator; Deckhand Scow Man; Dry Cement Handler; Environmental - Nuclear, Radiation, Toxic & Hazardous Waste - Level C; Forklift Operator for Masonary; Form Setter; Green Concrete Cutting; Hand Operated Grouter & Grinder Machine Operator; Jackhammer; Pavement Breaker; Paving Joint Machine; Pipelayer; Plastic Pipe Fusion; Power Driven Georgia Buggy & Wheel Barrow; Power Post Hole Digger; Precast Manhole Setter; Walk-Behind Tamper; Walk-Behind Trencher; Sand Blaster; Concrete Chipper; Surface Grinder; Vibrator Operator; Wagon Driller

GROUP 3 - Asphalt Luteman & Raker; Gunnite Nozzleman; Gunnite Operator & Mixer; Grout Pump Operator; Side Rail Setter; Rail Paved Ditches; Screw Operator; Tunnel (Free Air); Water Blaster

GROUP 4 - Caisson Worker (Free Air); Cement Finisher; Environmental - Nuclear, Radiation, Toxic & Hazardous Waste - Levels A & B; Miner & Driller (Free Air); Tunnel Blaster; & Tunnel Mucker (Free Air); Directional & Horizontal Boring; Air Track Drillers (All Types); Powdermen & Blasters; Troxler & Concrete Tester if Laborer is Utilized

 * LAB00189-008 07/01/2021

ANDERSON, BULLITT, CARROLL, HARDIN, HENRY, JEFFERSON, LARUE, MARION, MEADE, NELSON, OLDHAM, SHELBY, SPENCER, TRIMBLE & WASHINGTON COUNTIES

Rates Fringes

Laborers:

GROUP 1.....	\$ 23.51	16.22
GROUP 2.....	\$ 23.76	16.22
GROUP 3.....	\$ 23.81	16.22
GROUP 4.....	\$ 24.41	16.22

LABORERS CLASSIFICATIONS

GROUP 1 - Aging & Curing of Concrete; Asbestos Abatement Worker; Asphalt Plant; Asphalt; Batch Truck Dump; Carpenter Tender; Cement Mason Tender; Cleaning of Machines; Concrete; Demolition; Dredging; Environmental - Nuclear, Radiation, Toxic & Hazardous Waste - Level D; Flagperson; Grade Checker; Hand Digging & Hand Back Filling; Highway Marker Placer; Landscaping, Mesh Handler & Placer; Puddler; Railroad; Rip-rap & Grouter; Right-of-Way; Sign, Guard Rail & Fence Installer; Signal Person; Sound Barrier Installer; Storm & Sanitary Sewer; Swamper; Truck Spotter & Dumper; Wrecking of Concrete Forms; General Cleanup

GROUP 2 - Batter Board Man (Sanitary & Storm Sewer); Brickmason Tender; Mortar Mixer Operator; Scaffold Builder; Burner & Welder; Bushhammer; Chain Saw Operator; Concrete Saw Operator; Deckhand Scow Man; Dry Cement Handler; Environmental - Nuclear, Radiation, Toxic & Hazardous Waste - Level C; Forklift Operator for Masonary; Form Setter; Green Concrete Cutting; Hand Operated Grouter & Grinder Machine Operator; Jackhammer; Pavement Breaker; Paving Joint Machine; Pipelayer; Plastic Pipe Fusion; Power Driven Georgia Buggy & Wheel Barrow; Power Post Hole Digger; Precast Manhole Setter; Walk-Behind Tamper; Walk-Behind Trencher; Sand Blaster; Concrete Chipper; Surface Grinder; Vibrator Operator; Wagon Driller

GROUP 3 - Asphalt Luteman & Raker; Gunnite Nozzleman; Gunnite Operator & Mixer; Grout Pump Operator; Side Rail Setter; Rail Paved Ditches; Screw Operator; Tunnel (Free Air); Water Blaster

GROUP 4 - Caisson Worker (Free Air); Cement Finisher; Environmental - Nuclear, Radiation, Toxic & Hazardous Waste - Levels A & B; Miner & Driller (Free Air); Tunnel Blaster; & Tunnel Mucker (Free Air); Directional & Horizontal Boring; Air Track Drillers (All Types); Powdermen & Blasters; Troxler & Concrete Tester if Laborer is Utilized

 * LAB00189-009 07/01/2021

BRECKINRIDGE & GRAYSON COUNTIES

	Rates	Fringes
Laborers:		
GROUP 1.....	\$ 23.51	16.22
GROUP 2.....	\$ 23.76	16.22
GROUP 3.....	\$ 23.81	16.22
GROUP 4.....	\$ 24.41	16.22

LABORERS CLASSIFICATIONS

GROUP 1 - Aging & Curing of Concrete; Asbestos Abatement Worker; Asphalt Plant; Asphalt; Batch Truck Dump; Carpenter Tender; Cement Mason Tender; Cleaning of Machines; Concrete; Demolition; Dredging; Environmental - Nuclear, Radiation, Toxic & Hazardous Waste - Level D; Flagperson; Grade Checker; Hand Digging & Hand Back Filling; Highway Marker Placer; Landscaping, Mesh Handler & Placer; Puddler; Railroad; Rip-rap & Grouter; Right-of-Way; Sign, Guard Rail & Fence Installer; Signal Person; Sound Barrier Installer; Storm & Sanitary Sewer; Swamper; Truck Spotter & Dumper; Wrecking of Concrete Forms; General Cleanup

GROUP 2 - Batter Board Man (Sanitary & Storm Sewer);
Brickmason Tender; Mortar Mixer Operator; Scaffold Builder;
Burner & Welder; Bushhammer; Chain Saw Operator; Concrete
Saw Operator; Deckhand Scow Man; Dry Cement Handler;
Environmental - Nuclear, Radiation, Toxic & Hazardous Waste
- Level C; Forklift Operator for Masonary; Form Setter;
Green Concrete Cutting; Hand Operated Grouter & Grinder
Machine Operator; Jackhammer; Pavement Breaker; Paving
Joint Machine; Pipelayer; Plastic Pipe Fusion; Power Driven
Georgia Buggy & Wheel Barrow; Power Post Hole Digger;
Precast Manhole Setter; Walk-Behind Tamper; Walk-Behind
Trencher; Sand Blaster; Concrete Chipper; Surface Grinder;
Vibrator Operator; Wagon Driller

GROUP 3 - Asphalt Luteman & Raker; Gunnite Nozzleman;
Gunnite Operator & Mixer; Grout Pump Operator; Side Rail
Setter; Rail Paved Ditches; Screw Operator; Tunnel (Free
Air); Water Blaster

GROUP 4 - Caisson Worker (Free Air); Cement Finisher;
Environmental - Nuclear, Radiation, Toxic & Hazardous Waste
- Levels A & B; Miner & Driller (Free Air); Tunnel Blaster;
& Tunnel Mucker (Free Air); Directional & Horizontal
Boring; Air Track Drillers (All Types); Powdermen &
Blasters; Troxler & Concrete Tester if Laborer is Utilized

PAIN0012-005 06/11/2005

BATH, BOURBON, BOYLE, CLARK, FAYETTE, FLEMING, FRANKLIN,
HARRISON, JESSAMINE, MADISON, MERCER, MONTGOMERY, NICHOLAS,
ROBERTSON, SCOTT & WOODFORD COUNTIES:

	Rates	Fringes
PAINTER		
Bridge/Equipment Tender and/or Containment Builder..	\$ 18.90	5.90
Brush & Roller.....	\$ 21.30	5.90
Elevated Tanks; Steeplejack Work; Bridge & Lead Abatement.....	\$ 22.30	5.90
Sandblasting & Waterblasting.....	\$ 22.05	5.90
Spray.....	\$ 21.80	5.90

PAIN0012-017 05/01/2015

BRACKEN, GALLATIN, GRANT, MASON & OWEN COUNTIES:

	Rates	Fringes
PAINTER (Heavy & Highway Bridges - Guardrails - Lightpoles - Striping)		
Bridge Equipment Tender and Containment Builder.....	\$ 20.73	9.06
Brush & Roller.....	\$ 23.39	9.06
Elevated Tanks; Steeplejack Work; Bridge & Lead Abatement.....	\$ 24.39	9.06
Sandblasting & Water Blasting.....	\$ 24.14	9.06
Spray.....	\$ 23.89	9.06

PAIN0118-004 06/01/2018

ANDERSON, BRECKINRIDGE, BULLITT, CARROLL, GRAYSON, HARDIN,
HENRY, JEFFERSON, LARUE, MARION, MEADE, NELSON, OLDHAM, SHELBY,
SPENCER, TRIMBLE & WASHINGTON COUNTIES:

	Rates	Fringes
PAINTER		
Brush & Roller.....	\$ 22.00	12.52
Spray, Sandblast, Power Tools, Waterblast & Steam Cleaning.....	\$ 23.00	12.52

PAIN1072-003 12/01/2018

BOYD, CARTER, ELLIOTT, GREENUP, LEWIS and ROWAN COUNTIES

	Rates	Fringes
Painters:		
Bridges; Locks; Dams; Tension Towers & Energized Substations.....	\$ 33.33	18.50
Power Generating Facilities..	\$ 30.09	18.50

PLUM0248-003 06/01/2020

BOYD, CARTER, ELLIOTT, GREENUP, LEWIS & ROWAN COUNTIES:

	Rates	Fringes
Plumber and Steamfitter.....	\$ 37.05	21.48

PLUM0392-007 06/01/2018

BRACKEN, CARROLL (Eastern Half), GALLATIN, GRANT, MASON, OWEN &
ROBERTSON COUNTIES:

	Rates	Fringes
Plumbers and Pipefitters.....	\$ 32.01	19.67

* PLUM0502-003 08/01/2021

BRECKINRIDGE, BULLITT, CARROLL (Western Half), FRANKLIN
(Western three-fourths), GRAYSON, HARDIN, HENRY, JEFFERSON,
LARUE, MARION, MEADE, NELSON, OLDHAM, SHELBY, SPENCER, TRIMBLE &
WASHINGTON COUNTIES

	Rates	Fringes
PLUMBER.....	\$ 38.07	20.78

SUKY2010-160 10/08/2001

	Rates	Fringes
Truck drivers:		
GROUP 1.....	\$ 16.57	7.34
GROUP 2.....	\$ 16.68	7.34

GROUP 3.....	\$ 16.86	7.34
GROUP 4.....	\$ 16.96	7.34

TRUCK DRIVER CLASSIFICATIONS

GROUP 1 - Mobile Batch Truck Tender

GROUP 2 - Greaser; Tire Changer; & Mechanic Tender

GROUP 3 - Single Axle Dump; Flatbed; Semi-trailer or Pole Trailer when used to pull building materials and equipment; Tandem Axle Dump; Distributor; Mixer; & Truck Mechanic

GROUP 4 - Euclid & Other Heavy Earthmoving Equipment & Lowboy; Articulator Cat; 5-Axle Vehicle; Winch & A-Frame when used in transporting materials; Ross Carrier; Forklift when used to transport building materials; & Pavement Breaker

WELDERS - Receive rate prescribed for craft performing operation to which welding is incidental.

=====
Note: Executive Order (EO) 13706, Establishing Paid Sick Leave for Federal Contractors applies to all contracts subject to the Davis-Bacon Act for which the contract is awarded (and any solicitation was issued) on or after January 1, 2017. If this contract is covered by the EO, the contractor must provide employees with 1 hour of paid sick leave for every 30 hours they work, up to 56 hours of paid sick leave each year. Employees must be permitted to use paid sick leave for their own illness, injury or other health-related needs, including preventive care; to assist a family member (or person who is like family to the employee) who is ill, injured, or has other health-related needs, including preventive care; or for reasons resulting from, or to assist a family member (or person who is like family to the employee) who is a victim of, domestic violence, sexual assault, or stalking. Additional information on contractor requirements and worker protections under the EO is available at www.dol.gov/whd/govcontracts.

Unlisted classifications needed for work not included within the scope of the classifications listed may be added after award only as provided in the labor standards contract clauses (29CFR 5.5 (a) (1) (ii)).

The body of each wage determination lists the classification and wage rates that have been found to be prevailing for the cited type(s) of construction in the area covered by the wage determination. The classifications are listed in alphabetical order of "identifiers" that indicate whether the particular rate is a union rate (current union negotiated rate for local), a survey rate (weighted average rate) or a union average rate (weighted union average rate).

Union Rate Identifiers

A four letter classification abbreviation identifier enclosed

in dotted lines beginning with characters other than ""SU"" or ""UAVG"" denotes that the union classification and rate were prevailing for that classification in the survey. Example: PLUM0198-005 07/01/2014. PLUM is an abbreviation identifier of the union which prevailed in the survey for this classification, which in this example would be Plumbers. 0198 indicates the local union number or district council number where applicable, i.e., Plumbers Local 0198. The next number, 005 in the example, is an internal number used in processing the wage determination. 07/01/2014 is the effective date of the most current negotiated rate, which in this example is July 1, 2014.

Union prevailing wage rates are updated to reflect all rate changes in the collective bargaining agreement (CBA) governing this classification and rate.

Survey Rate Identifiers

Classifications listed under the ""SU"" identifier indicate that no one rate prevailed for this classification in the survey and the published rate is derived by computing a weighted average rate based on all the rates reported in the survey for that classification. As this weighted average rate includes all rates reported in the survey, it may include both union and non-union rates. Example: SULA2012-007 5/13/2014. SU indicates the rates are survey rates based on a weighted average calculation of rates and are not majority rates. LA indicates the State of Louisiana. 2012 is the year of survey on which these classifications and rates are based. The next number, 007 in the example, is an internal number used in producing the wage determination. 5/13/2014 indicates the survey completion date for the classifications and rates under that identifier.

Survey wage rates are not updated and remain in effect until a new survey is conducted.

Union Average Rate Identifiers

Classification(s) listed under the UAVG identifier indicate that no single majority rate prevailed for those classifications; however, 100% of the data reported for the classifications was union data. EXAMPLE: UAVG-OH-0010 08/29/2014. UAVG indicates that the rate is a weighted union average rate. OH indicates the state. The next number, 0010 in the example, is an internal number used in producing the wage determination. 08/29/2014 indicates the survey completion date for the classifications and rates under that identifier.

A UAVG rate will be updated once a year, usually in January of each year, to reflect a weighted average of the current negotiated/CBA rate of the union locals from which the rate is based.

WAGE DETERMINATION APPEALS PROCESS

1.) Has there been an initial decision in the matter? This can be:

- * an existing published wage determination
- * a survey underlying a wage determination

- * a Wage and Hour Division letter setting forth a position on a wage determination matter
- * a conformance (additional classification and rate) ruling

On survey related matters, initial contact, including requests for summaries of surveys, should be with the Wage and Hour Regional Office for the area in which the survey was conducted because those Regional Offices have responsibility for the Davis-Bacon survey program. If the response from this initial contact is not satisfactory, then the process described in 2.) and 3.) should be followed.

With regard to any other matter not yet ripe for the formal process described here, initial contact should be with the Branch of Construction Wage Determinations. Write to:

Branch of Construction Wage Determinations
Wage and Hour Division
U.S. Department of Labor
200 Constitution Avenue, N.W.
Washington, DC 20210

2.) If the answer to the question in 1.) is yes, then an interested party (those affected by the action) can request review and reconsideration from the Wage and Hour Administrator (See 29 CFR Part 1.8 and 29 CFR Part 7). Write to:

Wage and Hour Administrator
U.S. Department of Labor
200 Constitution Avenue, N.W.
Washington, DC 20210

The request should be accompanied by a full statement of the interested party's position and by any information (wage payment data, project description, area practice material, etc.) that the requestor considers relevant to the issue.

3.) If the decision of the Administrator is not favorable, an interested party may appeal directly to the Administrative Review Board (formerly the Wage Appeals Board). Write to:

Administrative Review Board
U.S. Department of Labor
200 Constitution Avenue, N.W.
Washington, DC 20210

4.) All decisions by the Administrative Review Board are final.

=====

END OF GENERAL DECISION"

Fringe benefit amounts are applicable for all hours worked except when otherwise noted.

No laborer, workman or mechanic shall be paid at a rate less than that of a Journeyman except those classified as bona fide apprentices.

Apprentices or trainees shall be permitted to work as such subject to Administrative Regulations adopted by the Commissioner of Workplace Standards. Copies of these regulations will be furnished upon request from any interested person.

Before using apprentices on the job the contractor shall present to the Contracting Officer written evidence of registration of such employees in a program of a State apprenticeship and training agency approved and recognized by the U. S. Bureau of Apprenticeship and Training. In the absence of such a State agency, the contractor shall submit evidence of approval and registration by the U. S. Bureau of Apprenticeship and Training.

The contractor shall submit to the Contracting Officer, written evidence of the established apprenticeship-journeyman ratios and wage rates in the project area, which will be the basis for establishing such ratios and rates for the project under the applicable contract provisions.

TO: EMPLOYERS/EMPLOYEES

PREVAILING WAGE SCHEDULE:

The wages indicated on this wage schedule are the least permitted to be paid for the occupations indicated. When an employee works in more than one classification, the employer must record the number of hours worked in each classification at the prescribed hourly base rate.

OVERTIME:

Overtime is to be paid to an employee at a rate not less than one and one-half times the basic rate of pay for all hours worked in excess of forty (40) hours in such workweek. Wage violations or questions should be directed to the designated Engineer or the undersigned.

Director
Division of Construction Procurement
Frankfort, Kentucky 40622
502-564-3500

**NOTICE OF REQUIREMENT FOR AFFIRMATIVE ACTION
TO ENSURE EQUAL EMPLOYMENT OPPORTUNITY
(Executive Order 11246)**

1. The Offeror's or Bidder's attention is called to the "Equal Opportunity Clause" and the "Standard Federal Equal Employment Specifications" set forth herein.
2. The goals and timetables for minority and female participation, expressed in percentage terms for the Contractor's aggregate work force in each trade on all construction work in the covered area, are as follows:

GOALS FOR MINORITY PARTICIPATION IN EACH TRADE	GOALS FOR FEMALE PARTICIPATION IN EACH TRADE
10.8%	6.9%

These goals are applicable to all the Contractor's construction work (whether or not it is Federal or federally-assisted) performed in the covered area. If the contractor performs construction work in a geographical area located outside of the covered area, it shall apply the goals established for such geographical area where the work is actually performed. With regard to this second area, the contractor also is subject to the goals for both its federally involved and non-federally involved construction.

The Contractor's compliance with the Executive Order and the regulations in CFR Part 60-4 shall be based on its implementation of the Equal Opportunity Clause, specific affirmative action obligations required by the specifications set forth in 41 CFR 60-4, 3(a), and its efforts to meet the goals. The hours of minority and female employment and training must be substantially uniform throughout the length of the contract, and in each trade, and the contractor shall make a good faith effort to employ minorities and women evenly on each of its projects. The transfer of minority or female employees or trainees from Contractor to Contractor or from project to project for the sole purpose of meeting the Contractor's goals shall be a violation of the contract, the Executive Order and the regulations in 41 CFR Part 60-4. Compliance with the goals will be measured against the total work hours performed.

3. The Contractor shall provide written notification to the Director of the Office of Federal Contract Compliance Programs within ten (10) working days of award of any construction subcontract in excess of \$10,000.00 at any tier for construction work under the contract resulting from this solicitation. The notification shall list the name, address and telephone number of the subcontractor; employer identification number of the subcontractor; estimated dollar amount of the subcontract; estimated starting and completion dates of the subcontract; and the geographical area in which the subcontract is to be performed. The notification shall be mailed to:

**Evelyn Teague, Regional Director
Office of Federal Contract Compliance Programs
61 Forsyth Street, SW, Suite 7B75
Atlanta, Georgia 30303-8609**

4. As used in this Notice, and in the contract resulting from this solicitation, the "**covered area**" is Fayette County.

PART IV
INSURANCE

Refer to
Kentucky Standard Specifications for Road and Bridge Construction,
current edition

PART V
BID ITEMS

PROPOSAL BID ITEMS

211049

Page 1 of 4

Report Date 10/29/21

Section: 0001 - PAVING

LINE	BID CODE	ALT	DESCRIPTION	QUANTITY	UNIT	UNIT PRIC	FP	AMOUNT
0010	00001		DGA BASE	100.00	TON		\$	
0020	00078		CRUSHED AGGREGATE SIZE NO 2	10.00	TON		\$	
0030	00194		LEVELING & WEDGING PG76-22	10.00	TON		\$	
0040	00216		CL3 ASPH BASE 1.00D PG76-22	18.00	TON		\$	
0050	00342		CL4 ASPH SURF 0.38A PG76-22	1,310.00	TON		\$	
0060	00356		ASPHALT MATERIAL FOR TACK	7.00	TON		\$	
0070	02058		REMOVE PCC PAVEMENT	2,611.00	SQYD		\$	
0080	02060		PCC PAVEMENT DIAMOND GRINDING	47,774.00	SQYD		\$	
0090	02071		JPC PAVEMENT-11 IN	2,611.00	SQYD		\$	
0100	02091		REMOVE PAVEMENT	38.00	SQYD		\$	
0110	02676		MOBILIZATION FOR MILL & TEXT	1.00	LS		\$	
0120	02677		ASPHALT PAVE MILLING & TEXTURING	1,310.00	TON		\$	
0130	20263ED		GEOGRID REINFORCEMENT FOR ASPHALT	38.00	SQYD		\$	
0140	24891EC		PAVE MOUNT INFRARED TEMP EQUIPMENT	142,947.00	SF		\$	

Section: 0002 - PAVING

LINE	BID CODE	ALT	DESCRIPTION	QUANTITY	UNIT	UNIT PRIC	FP	AMOUNT
0150	00001		DGA BASE	300.00	TON		\$	
0160	00078		CRUSHED AGGREGATE SIZE NO 2	40.00	TON		\$	
0170	00194		LEVELING & WEDGING PG76-22	500.00	TON		\$	
0180	00216		CL3 ASPH BASE 1.00D PG76-22	243.00	TON		\$	
0190	00342		CL4 ASPH SURF 0.38A PG76-22	23,771.00	TON		\$	
0200	00356		ASPHALT MATERIAL FOR TACK	121.00	TON		\$	
0210	02091		REMOVE PAVEMENT	519.00	SQYD		\$	
0220	02676		MOBILIZATION FOR MILL & TEXT	1.00	LS		\$	
0230	02677		ASPHALT PAVE MILLING & TEXTURING	23,771.00	TON		\$	
0240	20263ED		GEOGRID REINFORCEMENT FOR ASPHALT	519.00	SQYD		\$	
0250	24891EC		PAVE MOUNT INFRARED TEMP EQUIPMENT	2,593,206.00	SF		\$	

Section: 0003 - ROADWAY

LINE	BID CODE	ALT	DESCRIPTION	QUANTITY	UNIT	UNIT PRIC	FP	AMOUNT
0260	01985		DELINEATOR FOR BARRIER - YELLOW	12.00	EACH		\$	
0270	02115		SAW-CLEAN-RESEAL TVERSE JOINT	56,577.00	LF		\$	
0280	02116		SAW-CLEAN-RESEAL LONGIT JOINT	51,860.00	LF		\$	
0290	02237		DITCHING	6,088.00	LF		\$	
0300	02383		REMOVE & RESET GUARDRAIL	200.00	LF		\$	
0310	02562		TEMPORARY SIGNS	2,500.00	SQFT		\$	
0320	02650		MAINTAIN & CONTROL TRAFFIC	1.00	LS		\$	
0330	02775		ARROW PANEL	4.00	EACH		\$	
0340	05964		MAINTENANCE FERTILIZER	1.00	TON		\$	
0350	05985		SEEDING AND PROTECTION	100.00	SQYD		\$	

PROPOSAL BID ITEMS

211049

Page 2 of 4

Report Date 10/29/21

LINE	BID CODE	ALT	DESCRIPTION	QUANTITY	UNIT	UNIT PRIC	FP	AMOUNT
0360	06401		FLEXIBLE DELINEATOR POST-M/W	306.00	EACH		\$	
0370	06404		FLEXIBLE DELINEATOR POST-M/Y	288.00	EACH		\$	
0380	06412		STEEL POST MILE MARKERS	2.00	EACH		\$	
0390	06511		PAVE STRIPING-TEMP PAINT-6 IN	49,196.00	LF		\$	
0400	06542		PAVE STRIPING-THERMO-6 IN W	4,888.00	LF		\$	
0410	06543		PAVE STRIPING-THERMO-6 IN Y	3,398.00	LF		\$	
0420	06546		PAVE STRIPING-THERMO-12 IN W	3,733.00	LF		\$	
0430	06556		PAVE STRIPING-DUR TY 1-6 IN W	19,803.00	LF		\$	
0440	06557		PAVE STRIPING-DUR TY 1-6 IN Y	15,703.00	LF		\$	
0450	06560		PAVE STRIPING-DUR TY 1-12 IN W	1,671.00	LF		\$	
0460	06578		PAVE MARKING-THERMO MERGE ARROW	6.00	EACH		\$	
0470	06592		PAVEMENT MARKER TYPE V-B W/R	251.00	EACH		\$	
0480	06593		PAVEMENT MARKER TYPE V-B Y/R	198.00	EACH		\$	
0490	06600		REMOVE PAVEMENT MARKER TYPE V	449.00	EACH		\$	
0500	06613		INLAID PAVEMENT MARKER-B W/R	140.00	EACH		\$	
0510	06614		INLAID PAVEMENT MARKER-B Y/R	44.00	EACH		\$	
0520	10020NS		FUEL ADJUSTMENT	390.00	DOLL	\$1.00	\$	\$390.00
0530	20071EC		JOINT ADHESIVE	12,050.00	LF		\$	
0540	20411ED		LAW ENFORCEMENT OFFICER	250.00	HOURL		\$	
0550	20430ED		SAW CUT RUMBLE STRIPE	6,981.00	LF		\$	
0560	21173EC		SAW-CLEAN-RESEAL RANDOM CRACKS	158.00	LF		\$	
0570	22664EN		WATER BLASTING EXISTING STRIPE	49,196.00	LF		\$	
0580	22883EN		CONCRETE WEDGE CURB	200.00	LF		\$	
0590	24679ED		PAVE MARK THERMO CHEVRON	2,603.00	SQFT		\$	
0600	24997EC		PARTIAL DEPTH PATCHING-POLYMER MOD	178.00	CUFT		\$	
0610	25075EC		QUEUE PROTECTION VEHICLE	480.00	HOURL		\$	
0620	25117EC		FURNISH QUEUE PROTECTION VEHICLES	3.00	MONT		\$	
0630	26136EC		PORTABLE QUEUE WARNING ALERT SYSTEM	3.00	MONT		\$	
0640	26137EC		QUEUE WARNING PCMS	12.00	MONT		\$	
0650	26138EC		QUEUE WARNING PORTABLE RADAR SENSORS	12.00	MONT		\$	

Section: 0004 - ROADWAY

LINE	BID CODE	ALT	DESCRIPTION	QUANTITY	UNIT	UNIT PRIC	FP	AMOUNT
0660	01484		CURB BOX INLET TYPE B-T	1.00	EACH		\$	
0670	01984		DELINEATOR FOR BARRIER - WHITE	44.00	EACH		\$	
0680	01985		DELINEATOR FOR BARRIER - YELLOW	290.00	EACH		\$	
0690	02237		DITCHING	23,744.00	LF		\$	
0700	02351		GUARDRAIL-STEEL W BEAM-S FACE	175.00	LF		\$	
0710	02369		GUARDRAIL END TREATMENT TYPE 2A	1.00	EACH		\$	
0720	02383		REMOVE & RESET GUARDRAIL	1,762.00	LF		\$	
0730	02387		GUARDRAIL CONNECTOR TO BRIDGE END TY A-1	1.00	EACH		\$	
0740	02562		TEMPORARY SIGNS	5,000.00	SQFT		\$	
0750	02650		MAINTAIN & CONTROL TRAFFIC	1.00	LS		\$	
0760	02671		PORTABLE CHANGEABLE MESSAGE SIGN	6.00	EACH		\$	

PROPOSAL BID ITEMS

211049

Page 3 of 4

Report Date 10/29/21

LINE	BID CODE	ALT	DESCRIPTION	QUANTITY	UNIT	UNIT PRIC	FP	AMOUNT
0770	02775		ARROW PANEL	8.00	EACH		\$	
0780	05964		MAINTENANCE FERTILIZER	4.00	TON		\$	
0790	05985		SEEDING AND PROTECTION	200.00	SQYD		\$	
0800	06401		FLEXIBLE DELINEATOR POST-M/W	846.00	EACH		\$	
0810	06404		FLEXIBLE DELINEATOR POST-M/Y	342.00	EACH		\$	
0820	06412		STEEL POST MILE MARKERS	8.00	EACH		\$	
0830	06511		PAVE STRIPING-TEMP PAINT-6 IN	151,793.00	LF		\$	
0840	06542		PAVE STRIPING-THERMO-6 IN W	87,016.00	LF		\$	
0850	06543		PAVE STRIPING-THERMO-6 IN Y	55,407.00	LF		\$	
0860	06546		PAVE STRIPING-THERMO-12 IN W	5,824.00	LF		\$	
0870	06556		PAVE STRIPING-DUR TY 1-6 IN W	2,136.00	LF		\$	
0880	06557		PAVE STRIPING-DUR TY 1-6 IN Y	1,410.00	LF		\$	
0890	06568		PAVE MARKING-THERMO STOP BAR-24IN	110.00	LF		\$	
0900	06574		PAVE MARKING-THERMO CURV ARROW	42.00	EACH		\$	
0910	06578		PAVE MARKING-THERMO MERGE ARROW	6.00	EACH		\$	
0920	06613		INLAID PAVEMENT MARKER-B W/R	1,258.00	EACH		\$	
0930	06614		INLAID PAVEMENT MARKER-B Y/R	110.00	EACH		\$	
0940	10020NS		FUEL ADJUSTMENT	33,514.00	DOLL	\$1.00	\$	\$33,514.00
0950	10030NS		ASPHALT ADJUSTMENT	59,058.00	DOLL	\$1.00	\$	\$59,058.00
0960	20071EC		JOINT ADHESIVE	227,129.00	LF		\$	
0970	20362ES403		SHOULDER RUMBLE STRIPS-SAWED	19,590.00	LF		\$	
0980	20411ED		LAW ENFORCEMENT OFFICER	200.00	HOUR		\$	
0990	20430ED		SAW CUT RUMBLE STRIPE	90,365.00	LF		\$	
1000	22664EN		WATER BLASTING EXISTING STRIPE	151,793.00	LF		\$	
1010	22883EN		CONCRETE WEDGE CURB	1,737.00	LF		\$	
1020	24679ED		PAVE MARK THERMO CHEVRON	2,092.00	SQFT		\$	
1030	24683ED		PAVE MARKING-THERMO DOTTED LANE EXTEN	1,053.00	LF		\$	
1040	24899EC		PAVE MARKING-THERMO ELONG ROUTE SHIELD	14.00	EACH		\$	
1050	25075EC		QUEUE PROTECTION VEHICLE	960.00	HOUR		\$	
1060	25117EC		FURNISH QUEUE PROTECTION VEHICLES	6.00	MONT		\$	
1070	26136EC		PORTABLE QUEUE WARNING ALERT SYSTEM	6.00	MONT		\$	
1080	26137EC		QUEUE WARNING PCMS	24.00	MONT		\$	
1090	26138EC		QUEUE WARNING PORTABLE RADAR SENSORS	24.00	MONT		\$	

Section: 0005 - DRAINAGE

LINE	BID CODE	ALT	DESCRIPTION	QUANTITY	UNIT	UNIT PRIC	FP	AMOUNT
1100	01000		PERFORATED PIPE-4 IN	100.00	LF		\$	
1110	01010		NON-PERFORATED PIPE-4 IN	20.00	LF		\$	
1120	01020		PERF PIPE HEADWALL TY 1-4 IN	1.00	EACH		\$	
1130	01028		PERF PIPE HEADWALL TY 3-4 IN	1.00	EACH		\$	
1140	01691		FLUME INLET TYPE 2	1.00	EACH		\$	
1150	02220		FLOWABLE FILL	2.00	CUYD		\$	
1160	02483		CHANNEL LINING CLASS II	10.00	TON		\$	
1170	02484		CHANNEL LINING CLASS III	3.00	TON		\$	

PROPOSAL BID ITEMS

211049

Page 4 of 4

Report Date 10/29/21

LINE	BID CODE	ALT	DESCRIPTION	QUANTITY	UNIT	UNIT PRIC	FP	AMOUNT
1180	02602		FABRIC-GEOTEXTILE CLASS 1	100.00	SQYD		\$	
1190	02604		FABRIC-GEOTEXTILE CLASS 1A	100.00	SQYD		\$	
1200	02701		TEMP SILT FENCE	100.00	LF		\$	
1210	05950		EROSION CONTROL BLANKET	100.00	SQYD		\$	
1220	20366NN		REPLACE GRATE	1.00	EACH		\$	

Section: 0006 - DRAINAGE

LINE	BID CODE	ALT	DESCRIPTION	QUANTITY	UNIT	UNIT PRIC	FP	AMOUNT
1230	00461		CULVERT PIPE-15 IN	4.00	LF		\$	
1240	01000		PERFORATED PIPE-4 IN	200.00	LF		\$	
1250	01010		NON-PERFORATED PIPE-4 IN	40.00	LF		\$	
1260	01020		PERF PIPE HEADWALL TY 1-4 IN	2.00	EACH		\$	
1270	01028		PERF PIPE HEADWALL TY 3-4 IN	2.00	EACH		\$	
1280	01202		PIPE CULVERT HEADWALL-15 IN	1.00	EACH		\$	
1290	01691		FLUME INLET TYPE 2	6.00	EACH		\$	
1300	02220		FLOWABLE FILL	8.00	CUYD		\$	
1310	02483		CHANNEL LINING CLASS II	115.00	TON		\$	
1320	02484		CHANNEL LINING CLASS III	75.00	TON		\$	
1330	02602		FABRIC-GEOTEXTILE CLASS 1	100.00	SQYD		\$	
1340	02604		FABRIC-GEOTEXTILE CLASS 1A	100.00	SQYD		\$	
1350	02701		TEMP SILT FENCE	200.00	LF		\$	
1360	05950		EROSION CONTROL BLANKET	400.00	SQYD		\$	
1370	20366NN		REPLACE GRATE	7.00	EACH		\$	

Section: 0007 - TRAFFIC LOOPS

LINE	BID CODE	ALT	DESCRIPTION	QUANTITY	UNIT	UNIT PRIC	FP	AMOUNT
1380	04793		CONDUIT-1 1/4 IN	160.00	LF		\$	
1390	04795		CONDUIT-2 IN	40.00	LF		\$	
1400	04820		TRENCHING AND BACKFILLING	180.00	LF		\$	
1410	04829		PIEZOELECTRIC SENSOR	13.00	EACH		\$	
1420	04830		LOOP WIRE	5,900.00	LF		\$	
1430	04895		LOOP SAW SLOT AND FILL	1,190.00	LF		\$	
1440	20359NN		GALVANIZED STEEL CABINET	4.00	EACH		\$	
1450	20360ES818		WOOD POST	8.00	EACH		\$	
1460	20391NS835		ELECTRICAL JUNCTION BOX TYPE A	4.00	EACH		\$	

Section: 0008 - DEMOBILIZATION AND/OR MOBILIZATION

LINE	BID CODE	ALT	DESCRIPTION	QUANTITY	UNIT	UNIT PRIC	FP	AMOUNT
1470	02568		MOBILIZATION	1.00	LS		\$	
1480	02569		DEMOBILIZATION	1.00	LS		\$	