



CALL NO. 108

CONTRACT ID. 224430

WARREN COUNTY

FED/STATE PROJECT NUMBER HSIP 5081(006)

DESCRIPTION NASHVILLE ROAD (US 31W)

WORK TYPE SIGNS-LIGHTING-SIGNALS

PRIMARY COMPLETION DATE 11/15/2022

LETTING DATE: May 26,2022

Sealed Bids will be received electronically through the Bid Express bidding service until 10:00 AM EASTERN DAYLIGHT TIME May 26,2022. Bids will be publicly announced at 10:00 AM EASTERN DAYLIGHT TIME.

NO PLANS ASSOCIATED WITH THIS PROJECT.

DBE CERTIFICATION REQUIRED - 0%

REQUIRED BID PROPOSAL GUARANTY: Not less than 5% of the total bid.

TABLE OF CONTENTS

PART I	SCOPE OF WORK
	<ul style="list-style-type: none">• PROJECT(S), COMPLETION DATE(S), & LIQUIDATED DAMAGES• CONTRACT NOTES• FEDERAL CONTRACT NOTES• DGA BASE• SPECIAL NOTE(S) APPLICABLE TO PROJECT• LIQUIDATED DAMAGES• WASTE AND BORROW SITES• COORDINATION OF WORK WITH OTHER CONTRACTS• TYPICAL SECTION DIMENSIONS• TRAFFIC CONTROL PLAN• TRAFFIC SIGNAL LOOP DETECTORS• RIGHT OF WAY CERTIFICATION• UTILITY IMPACT & RAIL CERTIFICATION NOTES• SKETCH MAP(S)• SUMMARY SHEET(S)• TYPICAL SECTION(S)• DETAIL SHEET(S)
PART II	SPECIFICATIONS AND STANDARD DRAWINGS
	<ul style="list-style-type: none">• SPECIFICATIONS REFERENCE• SUPPLEMENTAL SPECIFICATION• [SN-1I] PORTABLE CHANGEABLE SIGNS• [SN-11M] BARCODE LABEL ON PERMANENT SIGNS• 2020 STANDARD DRAWINGS THAT APPLY
PART III	EMPLOYMENT, WAGE AND RECORD REQUIREMENTS
	<ul style="list-style-type: none">• FEDERAL-AID CONSTRUCTION CONTRACTS - FHWA 1273• NONDISCRIMINATION OF EMPLOYEES• EXECUTIVE BRANCH CODE OF ETHICS• PROJECT WAGE RATES LOCALITY 1 / FEDERAL• NOTICE OF REQUIREMENT FOR AFFIRMATIVE ACTION TO ENSURE EEO WARREN
PART IV	INSURANCE
PART V	BID ITEMS

PART I
SCOPE OF WORK

ADMINISTRATIVE DISTRICT - 03

CONTRACT ID - 224430

HSIP 5081(006)

COUNTY - WARREN

PCN - 03114031W2201

HSIP 5081(006)

NASHVILLE ROAD (US 31W) (MP 1.275) FROM 1.3 MILES NORTH OF THE WARREN COUNTY LINE EXTENDING NORTH TO 0.2 MILE NORTH OF KY 240 (MP 1.653), A DISTANCE OF 0.38 MILES.SIGNS-LIGHTING-SIGNALS SYP NO. 03-00933.00.

GEOGRAPHIC COORDINATES LATITUDE 36:50:44.74 LONGITUDE 86:32:15.62

ADT 8,894

COMPLETION DATE(S):

COMPLETED BY 11/15/2022

APPLIES TO ENTIRE PROJECT

CONTRACT NOTES

PROPOSAL ADDENDA

All addenda to this proposal must be applied when calculating bid and certified in the bid packet submitted to the Kentucky Department of Highways. Failure to use the correct and most recent addenda may result in the bid being rejected.

BID SUBMITTAL

Bidder must use the Department's electronic bidding software. The Bidder must download the bid file located on the Bid Express website (www.bidx.com) to prepare a bid packet for submission to the Department. The bidder must submit electronically using Bid Express.

JOINT VENTURE BIDDING

Joint venture bidding is permissible. All companies in the joint venture must be prequalified in one of the work types in the Qualifications for Bidders for the project. The bidders must get a vendor ID for the joint venture from the Division of Construction Procurement and register the joint venture as a bidder on the project. Also, the joint venture must obtain a digital ID from Bid Express to submit a bid. A joint bid bond of 5% may be submitted for both companies or each company may submit a separate bond of 5%.

UNDERGROUND FACILITY DAMAGE PROTECTION

The contractor shall make every effort to protect underground facilities from damage as prescribed in the Underground Facility Damage Protection Act of 1994, Kentucky Revised Statute KRS 367.4901 to 367.4917. It is the contractor's responsibility to determine and take steps necessary to be in compliance with federal and state damage prevention directives. When prescribed in said directives, the contractor shall submit Excavation Locate Requests to the Kentucky Contact Center (KY811) via web ticket entry. The submission of this request does not relieve the contractor from the responsibility of contacting non-member facility owners, whom shall be contacted through their individual Protection Notification Center. Non-compliance with these directives can result in the enforcement of penalties.

REGISTRATION WITH THE SECRETARY OF STATE BY A FOREIGN ENTITY

Pursuant to KRS 176.085(1)(b), an agency, department, office, or political subdivision of the Commonwealth of Kentucky shall not award a state contract to a person that is a foreign entity required by [KRS 14A.9-010](#) to obtain a certificate of authority to transact business in the Commonwealth ("certificate") from the Secretary of State under [KRS 14A.9-030](#) unless the person produces the certificate within fourteen (14) days of the bid or proposal opening. If the foreign entity is not required to obtain a certificate as provided in [KRS 14A.9-010](#), the foreign entity should identify the applicable exception. Foreign entity is defined within [KRS 14A.1-070](#).

For all foreign entities required to obtain a certificate of authority to transact business in the Commonwealth, if a copy of the certificate is not received by the contracting agency within the time frame identified above, the foreign entity's solicitation response shall be deemed non-responsive or the awarded contract shall be cancelled.

Businesses can register with the Secretary of State at <https://secure.kentucky.gov/sos/ftbr/welcome.aspx>.

SPECIAL NOTE FOR PROJECT QUESTIONS DURING ADVERTISEMENT

Questions about projects during the advertisement should be submitted in writing to the Division of Construction Procurement. This may be done by fax (502) 564-7299 or email to kytc.projectquestions@ky.gov. The Department will attempt to answer all submitted questions. The Department reserves the right not to answer if the question is not pertinent or does not aid in clarifying the project intent.

The deadline for posting answers will be 3:00 pm Eastern Daylight Time, the day preceding the Letting. Questions may be submitted until this deadline with the understanding that the later a question is submitted, the less likely an answer will be able to be provided.

The questions and answers will be posted for each Letting under the heading "Questions & Answers" on the Construction Procurement website (www.transportation.ky.gov/contract). The answers provided shall be considered part of this Special Note and, in case of a discrepancy, will govern over all other bidding documents.

HARDWOOD REMOVAL RESTRICTIONS

The US Department of Agriculture has imposed a quarantine in Kentucky and several surrounding states, to prevent the spread of an invasive insect, the emerald ash borer. Hardwood cut in conjunction with the project may not be removed from the state. Chipping or burning on site is the preferred method of disposal.

INSTRUCTIONS FOR EXCESS MATERIAL SITES AND BORROW SITES

Identification of excess material sites and borrow sites shall be the responsibility of the Contractor. The Contractor shall be responsible for compliance with all applicable state and federal laws and may wish to consult with the US Fish and Wildlife Service to seek protection under Section 10 of the Endangered Species Act for these activities.

ACCESS TO RECORDS

The contractor, as defined in KRS 45A.030 (9) agrees that the contracting agency, the Finance and Administration Cabinet, the Auditor of Public Accounts, and the Legislative Research Commission, or their duly authorized representatives, shall have access to any books, documents, papers, records, or other evidence, which are directly pertinent to this contract for the purpose of financial audit or program review. Records and other prequalification information confidentially

disclosed as part of the bid process shall not be deemed as directly pertinent to the contract and shall be exempt from disclosure as provided in KRS 61.878(1)(c). The contractor also recognizes that any books, documents, papers, records, or other evidence, received during a financial audit or program review shall be subject to the Kentucky Open Records Act, KRS 61.870 to 61.884.

In the event of a dispute between the contractor and the contracting agency, Attorney General, or the Auditor of Public Accounts over documents that are eligible for production and review, the Finance and Administration Cabinet shall review the dispute and issue a determination, in accordance with Secretary's Order 11-004.

April 30, 2018

FEDERAL CONTRACT NOTES

The Kentucky Department of Highways, in accordance with the Regulations of the United States Department of Transportation 23 CFR 635.112 (h), hereby notifies all bidders that failure by a bidder to comply with all applicable sections of the current Kentucky Standard Specifications, including, but not limited to the following, may result in a bid not being considered responsive and thus not eligible to be considered for award:

- | | |
|--------------------------------|--|
| 102.02 Current Rating | 102.08 Preparation and Delivery of Proposals |
| 102.13 Irregular Bid Proposals | 102.14 Disqualification of Bidders |
| 102.09 Proposal Guaranty | |

CIVIL RIGHTS ACT OF 1964

The Kentucky Transportation Cabinet, Department of Highways, in accordance with the provisions of Title VI of the Civil Rights Act of 1964 (78 Stat. 252, 42 U.S.C. §§ 2000d to 2000d-4) and the Regulations, hereby notifies all bidders that it will affirmatively ensure that any contract entered into pursuant to this advertisement, disadvantaged business enterprises will be afforded full and fair opportunity to submit bids in response to this invitation and will not be discriminated against on the grounds of race, color, national origin, sex, age (over 40), religion, sexual orientation, gender identity, veteran status, disability, income- level, or Limited English Proficiency (LEP) in consideration for an award.

NOTICE TO ALL BIDDERS

To report bid rigging activities call: 1-800-424-9071.

The U.S. Department of Transportation (DOT) operates the above toll-free “hotline” Monday through Friday, 8:00 a.m. to 5:00 p.m. eastern time. Anyone with knowledge of possible bid rigging, bidder collusion, or other fraudulent activities should use the “hotline” to report such activities.

The “hotline” is part of the DOT’s continuing effort to identify and investigate highway construction contract fraud and abuse and is operated under the direction of the DOT Inspector General. All information will be treated confidentially and caller anonymity will be respected.

SECOND TIER SUBCONTRACTS

Second tier subcontracts are acceptable per Section 108.01 of the Standard Specifications for Road and Bridge Construction. Sub-Contractors fulfilling a disadvantaged business enterprise goal on a project may enter into a 2nd tier subcontract with a Non-DBE Subcontractor. However, in this instance, none of the work subcontracted to the Non-DBE Contractor will count toward fulfilling the established Disadvantaged Goal for the project.

DISADVANTAGED BUSINESS ENTERPRISE PROGRAM

It is the policy of the Kentucky Transportation Cabinet (“the Cabinet”) that Disadvantaged Business Enterprises (“DBE”) shall have the opportunity to participate in the performance of highway construction projects financed in whole or in part by Federal Funds in order to create a level playing field for all businesses who wish to contract with the Cabinet. To that end, the Cabinet will comply with the regulations found in 49 CFR Part 26, and the definitions and requirements contained therein shall be adopted as if set out verbatim herein.

The Cabinet, contractors, subcontractors, and sub-recipients shall not discriminate on the basis of race, color, national origin, or sex in the performance of work performed pursuant to Cabinet contracts. The contractor shall carry out applicable requirements of 49 CFR 26 in the award and administration of federally assisted highway construction projects. The contractor will include this provision in all its subcontracts and supply agreements pertaining to contracts with the Cabinet.

Failure by the contractor to carry out these requirements is a material breach of its contract with the Cabinet, which may result in the termination of the contract or such other remedy as the Cabinet deems necessary.

DBE GOAL

The Disadvantaged Business Enterprise (DBE) goal established for this contract, as listed on the front page of the proposal, is the percentage of the total value of the contract.

The contractor shall exercise all necessary and reasonable steps to ensure that Disadvantaged Business Enterprises participate in a least the percent of the contract as set forth above as goals for this contract.

OBLIGATION OF CONTRACTORS

Each contractor prequalified to perform work on Cabinet projects shall designate and make known to the Cabinet a liaison officer who is assigned the responsibility of effectively administering and promoting an active program for utilization of DBEs.

If a formal goal has not been designated for the contract, all contractors are encouraged to consider DBEs for subcontract work as well as for the supply of material and services needed to perform this work.

Contractors are encouraged to use the services of banks owned and controlled by minorities and women.

CERTIFICATION OF CONTRACT GOAL

Contractors shall include the following certification in bids for projects for which a DBE goal has been established. BIDS SUBMITTED WHICH DO NOT INCLUDE CERTIFICATION OF DBE PARTICIPATION WILL NOT BE ACCEPTED. These bids will not be considered for award by the Cabinet and they will be returned to the bidder.

“The bidder certifies that it has secured participation by Disadvantaged Business Enterprises (“DBE”) in the amount of _____ percent of the total value of this contract and that the DBE participation is in compliance with the requirements of 49 CFR 26 and the policies of the Kentucky Transportation Cabinet pertaining to the DBE Program.”

The certification statement is located in the electronic bid file. All contractors must certify their DBE participation on that page. DBEs utilized in achieving the DBE goal must be certified and prequalified for the work items at the time the bid is submitted.

DBE PARTICIPATION PLAN

Lowest responsive bidders must submit the *DBE Plan/ Subcontractor Request*, form TC 14-35 DBE, within **5** days of the letting. This is necessary before the Awards Committee will review and make a recommendation. **The project will not be considered for award prior to submission and approval of the apparent low bidder’s DBE Plan/Subcontractor Request.**

The DBE Participation Plan shall include the following:

1. Name and address of DBE Subcontractor(s) and/or supplier(s) intended to be used in the proposed project;
2. Description of the work each is to perform including the work item, unit, quantity, unit price and total amount of the work to be performed by the individual DBE. The Proposal Line Number, Category Number, and the Project Line Number can be found in the “material listing” on the Construction Procurement website under the specific letting;
3. The dollar value of each proposed DBE subcontract and the percentage of total project contract value this represents. DBE participation may be counted as follows:
 - a. If DBE suppliers and manufactures assume actual and contractual responsibility, the dollar value of materials to be furnished will be counted toward the goal as follows:
 - The entire expenditure paid to a DBE manufacturer;
 - 60 percent of expenditures to DBE suppliers that are not manufacturers provided the supplier is a regular dealer in the product involved. A regular dealer must be engaged in, as its principal business and in its own name, the sale of products to the public, maintain an inventory and own and operate distribution equipment; and
 - The amount of fees or commissions charged by the DBE firms for a bona fide service, such as professional, technical, consultant, or managerial services and assistance in the procurement of essential personnel, facilities, equipment, materials, supplies, delivery of materials and supplies or for furnishing bonds, or insurance, providing such fees or commissions are determined to be reasonable and customary.

- b) The dollar value of services provided by DBEs such as quality control testing, equipment repair and maintenance, engineering, staking, etc.;
- c) The dollar value of joint ventures. DBE credit for joint ventures will be limited to the dollar amount of the work actually performed by the DBE in the joint venture;
- 4. Written and signed documentation of the bidder's commitment to use a DBE contractor whose participation is being utilized to meet the DBE goal; and
- 5. Written and signed confirmation from the DBE that it is participating in the contract as provided in the prime contractor's commitment.

UPON AWARD AND BEFORE A WORK ORDER WILL BE ISSUED

Contractors must submit the signed subcontract between the contractor and the DBE contractor, along with the DBE's certificate of insurance. If the DBE is a supplier of materials for the project, a signed purchase order must be submitted to the Division of Construction Procurement.

Changes to DBE Participation Plans must be approved by the Cabinet. The Cabinet may consider extenuating circumstances including, but not limited to, changes in the nature or scope of the project, the inability or unwillingness of a DBE to perform the work in accordance with the bid, and/or other circumstances beyond the control of the prime contractor.

CONSIDERATION OF GOOD FAITH EFFORTS REQUESTS

If the DBE participation submitted in the bid by the apparent lowest responsive bidder does not meet or exceed the DBE contract goal, the apparent lowest responsive bidder must submit a Good Faith Effort Package to satisfy the Cabinet that sufficient good faith efforts were made to meet the contract goals prior to submission of the bid. Efforts to increase the goal after bid submission will not be considered in justifying the good faith effort, unless the contractor can show that the proposed DBE was solicited prior to the letting date. DBEs utilized in achieving the DBE goal must be certified and prequalified for the work items at the time the bid is submitted. One complete set (hard copy along with an electronic copy) of this information must be received in the Division of Contract Procurement no later than 12:00 noon of the tenth calendar day after receipt of notification that they are the apparent low bidder.

Where the information submitted includes repetitious solicitation letters it will be acceptable to submit a sample representative letter along with a distribution list of the firms solicited. Documentation of DBE quotations shall be a part of the good faith effort submittal as necessary to demonstrate compliance with the factors listed below which the Cabinet considers in judging good faith efforts. This documentation may include written subcontractors' quotations, telephone log notations of verbal quotations, or other types of quotation documentation.

The Good Faith Effort Package shall include, but may not be limited to information showing evidence of the following:

1. Whether the bidder attended any pre-bid meetings that were scheduled by the Cabinet to inform DBEs of subcontracting opportunities;
2. Whether the bidder provided solicitations through all reasonable and available means;
3. Whether the bidder provided written notice to all DBEs listed in the DBE directory at the time of the letting who are prequalified in the areas of work that the bidder will be subcontracting;
4. Whether the bidder followed up initial solicitations of interest by contacting DBEs to determine with certainty whether they were interested. If a reasonable amount of DBEs within the targeted districts do not provide an intent to quote or no DBEs are prequalified in the subcontracted areas, the bidder must notify the Disadvantaged Enterprise Business Liaison Officer (DEBLO) in the Office for Civil Rights and Small Business Development to give notification of the bidder's inability to get DBE quotes;
5. Whether the bidder selected portions of the work to be performed by DBEs in order to increase the likelihood of meeting the contract goals. This includes, where appropriate, breaking out contract work items into economically feasible units to facilitate DBE participation, even when the prime contractor might otherwise perform these work items with its own forces;
6. Whether the bidder provided interested DBEs with adequate and timely information about the plans, specifications, and requirements of the contract;
7. Whether the bidder negotiated in good faith with interested DBEs not rejecting them as unqualified without sound reasons based on a thorough investigation of their capabilities. Any rejection should be so noted in writing with a description as to why an agreement could not be reached;
8. Whether quotations were received from interested DBE firms but were rejected as unacceptable without sound reasons why the quotations were considered unacceptable. The fact that the DBE firm's quotation for the work is not the lowest quotation received will not in itself be considered as a sound reason for rejecting the quotation as unacceptable. The fact that the bidder has the ability and/or desire to perform the contract work with its own forces will not be considered a sound reason for rejecting a DBE quote. Nothing in this provision shall be construed to require the bidder to accept unreasonable quotes in order to satisfy DBE goals;
9. Whether the bidder specifically negotiated with subcontractors to assume part of the responsibility to meet the contract DBE goal when the work to be subcontracted includes potential DBE participation;
10. Whether the bidder made any efforts and/or offered assistance to interested DBEs in obtaining the necessary equipment, supplies, materials, insurance and/or bonding to satisfy the work requirements of the bid proposal; and
11. Any other evidence that the bidder submits which may show that the bidder has made reasonable good faith efforts to include DBE participation.

FAILURE TO MEET GOOD FAITH REQUIREMENT

Where the apparent lowest responsive bidder fails to submit sufficient participation by DBE firms to meet the contract goal and upon a determination by the Good Faith Committee based upon the information submitted that the apparent lowest responsive bidder failed to make sufficient reasonable efforts to meet the contract goal, the bidder will be offered the opportunity to meet in person for administrative reconsideration. The bidder will be notified of the Committee's decision within 24 hours of its decision. The bidder will have 24 hours to request reconsideration of the Committee's decision. The reconsideration meeting will be held within two days of the receipt of a request by the bidder for reconsideration.

The request for reconsideration will be heard by the Office of the Secretary. The bidder will have the opportunity to present written documentation or argument concerning the issue of whether it met the goal or made an adequate good faith effort. The bidder will receive a written decision on the reconsideration explaining the basis for the finding that the bidder did or did not meet the goal or made adequate Good Faith efforts to do so.

The result of the reconsideration process is not administratively appealable to the Cabinet or to the United States Department of Transportation.

The Cabinet reserves the right to award the contract to the next lowest responsive bidder or to rebid the contract in the event that the contract is not awarded to the low bidder as the result of a failure to meet the good faith requirement.

SANCTIONS FOR FAILURE TO MEET DBE REQUIREMENTS OF THE PROJECT

Failure by the prime contractor to fulfill the DBE requirements of a project under contract or to demonstrate good faith efforts to meet the goal constitutes a breach of contract. When this occurs, the Cabinet will hold the prime contractor accountable, as would be the case with all other contract provisions. Therefore, the contractor's failure to carry out the DBE contract requirements shall constitute a breach of contract and as such the Cabinet reserves the right to exercise all administrative remedies at its disposal including, but not limited to the following:

- Suspension of Prequalification;
- Disallow credit toward the DBE goal;
- Withholding progress payments;
- Withholding payment to the prime in an amount equal to the unmet portion of the contract goal; and/or
- Termination of the contract.

PROMPT PAYMENT

The prime contractor will be required to pay the DBE and Non-DBE Subcontractors within seven (7) working days after he or she has received payment from the Kentucky Transportation Cabinet for work performed or materials furnished.

CONTRACTOR REPORTING

All contractors must keep detailed records and provide reports to the Cabinet on their progress in meeting the DBE requirement on any highway contract. These records may include, but shall not be limited to payroll, lease agreements, cancelled payroll checks, executed subcontracting agreements, etc. Prime contractors will be required to complete and submit a **signed and notarized** Affidavit of Subcontractor Payment (TC 18-7) and copies of checks for any monies paid to each DBE subcontractor or supplier utilized to meet a DBE goal. These documents must be completed and signed within 7 days of being paid by the Cabinet.

Payment information that needs to be reported includes date the payment is sent to the DBE, check number, Contract ID, amount of payment and the check date. Before Final Payment is made on this contract, the Prime Contractor will certify that all payments were made to the DBE subcontractor and/or DBE suppliers.

***** IMPORTANT *****

Please mail the original, signed and completed TC (18-7) Affidavit of Subcontractor Payment form and all copies of checks for payments listed above to the following address:

Office for Civil Rights and Small Business Development
6th Floor West 200 Mero Street
Frankfort, KY 40622

The prime contractor should notify the KYTC Office for Civil Rights and Small Business Development seven (7) days prior to DBE contractors commencing work on the project. The contact in this office is Mr. Melvin Byne. Mr. Byne's current contact information is email address – melvin.bynes2@ky.gov and the telephone number is (502) 564-3601.

DEFAULT OR DECERTIFICATION OF THE DBE

If the DBE subcontractor or supplier is decertified or defaults in the performance of its work, and the overall goal cannot be credited for the uncompleted work, the prime contractor may utilize a substitute DBE or elect to fulfill the DBE goal with another DBE on a different work item. If after exerting good faith effort in accordance with the Cabinet's Good Faith Effort policies and procedures, the prime contractor is unable to replace the DBE, then the unmet portion of the goal may be waived at the discretion of the Cabinet.

PROHIBITION ON TELECOMMUNICATIONS EQUIPMENT OR SERVICES

In accordance with the FY 2019 National Defense Authorization Act (NDAA), 2 CFR 200.216, and 2 CFR 200.471, Federal agencies are prohibited, after August 13, 2020, from obligating or expending financial assistance to obtain certain telecommunications and video surveillance services and equipment from specific producers. As a result of these regulations, contractors and subcontractors are prohibited, on projects with federal funding participation, from providing telecommunication or video surveillance equipment, services, or systems produced by:

- Huawei Technologies Company or ZTE Corporation (or any subsidiary or affiliate of such entities)
- Hytera Communications Corporation, Hangzhou Hikvision Digital Technology Company, or Dahua Technology Company (or any subsidiary or affiliate of such entities)

LEGAL REQUIREMENTS AND RESPONSIBILITY TO THE PUBLIC – CARGO PREFERENCE ACT (CPA).

(REV 12-17-15) (1-16)

SECTION 7 is expanded by the following new Article:

102.10 **Cargo Preference Act – Use of United States-flag vessels.**

Pursuant to Title 46CFR Part 381, the Contractor agrees

- To utilize privately owned United States-flag commercial vessels to ship at least 50 percent of the gross tonnage (computed separately for dry bulk carriers, dry cargo liners, and tankers) involved, whenever shipping any equipment, material, or commodities pursuant to this contract, to the extent such vessels are available at fair and reasonable rates for United States-flag commercial vessels.
- To furnish within 20 days following the date of loading for shipments originating within the United States or within 30 working days following the date of loading for shipments originating outside the United States, a legible copy of a rated, 'on-board' commercial ocean bill-of-lading in English for each shipment of cargo described in paragraph 1 of this section to both the Contracting Officer (through the prime contractor in the case of subcontractor bills-of-lading) and to the Division of National Cargo, Office of Market Development, Maritime Administration, Washington, DC 20590.
- To insert the substance of the provisions of this clause in all subcontracts issued pursuant to this contract.

DGA BASE

Unless otherwise noted, the Department estimates the rate of application for DGA Base to be 115 lbs/sy per inch of depth.

Special Notes Applicable to Project – General Notes & Description of Work

CAUTION

The information in this proposal and the type of work listed herein are approximate only and are not to be taken as an exact evaluation of the materials and conditions to be encountered during construction; the bidder must draw his/her own conclusions when developing the Unit Bid Prices for each bid item. As such, if the conditions encountered are not in accordance with the information shown, the Department does not guarantee any changes to the Unit Bid Prices nor extension of the contract will be considered. The Department will pay for bid item quantity overruns, but only if pre-approved by the Engineer.

STATIONING

The contractor is advised that the planned locations of work were established from a beginning station number, which is STA 77+30 at the intersection of US 31W and KY 240, and corresponds to Milepoint 1.464 along US 31W. **NOTE:** The existing mile marker signs may not correspond to the proposed work locations.

LIDAR

All survey information was obtained from available KYTC Aerial LIDAR data and should be field verified as appropriate during construction and prior to incorporating the various project work items. Refer to the Special Note for Staking concerning staking operations required to control and construct the work.

ON-SITE INSPECTION

Before submitting a bid for the work, make a thorough inspection of the site and determine existing conditions so that the work can be expeditiously performed after a contract is awarded. The Department will consider submission of a bid to be evidence of this inspection having been made. The Department will not honor any claims for money or time extension resulting from site conditions.

RIGHT OF WAY LIMITS

The Department has not established the exact limits of the Right-of-Way. Unless a consent and release form is obtained from the adjoining property owner, limit work activities to the obvious Right-of-Way and staging areas secured and environmentally cleared by the Contractor at no additional cost to the Department. In the event that private improvements (i.e. fences, buildings, etc.) encroach upon the Right-of-Way, the contractor shall notify the Engineer and limit work activities in order to NOT disturb the improvements. If they become necessary, the Department will secure consent and releases from property owners through the Engineer. Be responsible for all encroachments onto private lands.

CONTROL

Perform all work under the absolute control of the Department of Highways. Obtain the Engineer's approval of all designs required to be furnished by the Contractor prior to incorporation into the work. The Department reserves the right to have other work performed by other contractors and its own forces and to permit public utility companies and others to do work during the construction within the limits of, or adjacent to, the project. Conduct operations and cooperate with such other parties so that interference with such other work will be reduced to a minimum. The Department will not honor any claims for money or time extension created by the operations of such other parties. Should a difference of opinion arise as to the rights of the Contractor and others working within the limits of, or adjacent to, the project, the Engineer will decide as to the respective rights of the various parties involved in order to assure the completion of the Department's work in general harmony and in a satisfactory manner, and his/her decision shall be final and binding upon the Contractor.

General Notes & Description of Work
Page 2 of 2

DESCRIPTION OF WORK

Except as specified herein, perform all work in accordance with the Department's Standard Specifications, Supplemental Specifications, applicable Special Notes and Special Provisions, and applicable Standard and Sepia Drawings, current editions. Furnish all materials, labor, equipment, and incidentals for the following work:

Intersection Conflict Warning System (ICWS). This work consists of installing an intersection conflict warning system at the intersection of US 31W and KY 240, including all operations associated with this improvement, including installing signs and all other work contained in the plans.

Standard Median Barrier, Type 2: This work consists of installing a concrete median barrier on the southwest corner of the intersection to protect the ICWS pole.

Thermo Pavement Markings: Quantities of thermo pavement markings have been included in this proposal (CID 224430) for the proposed intersection pavement markings. The Engineer will make the final determination as to the quantities and placement of the thermo pavement markings.

NOTE: Be advised there is an active Rural Secondary Resurfacing Project on KY 240. The Engineer will coordinate any overlapping work of the Contractors. See Section 105.06.

Special Note for Staking

Perform Contractor Staking according to Section 201; except, in addition to the requirements of Section 201, perform the following:

1. Contrary to Section 201.03.01, perform items 1 & 2 usually performed by the Engineer.
2. Using the proposed pavement superelevation rates, runout lengths, and runoff lengths, determine the necessary elevation changes along the edges of pavement for each proposed curve and the transitions leading into and out of each curve to achieve the proposed superelevation improvements. The intent is to provide a consistent superelevation throughout each proposed curve and smooth transitions into and out of each curve. Once the elevation changes along the edges of pavement for each proposed curve are determined and prior to starting paving operations, verify the proposed roadside re-grading corresponding to each curve can be constructed so that the new roadside will be flush with the new edges of pavement and the new toe of slope, or top of cut, will remain within the Right-of-Way, or within the general area noted on any applicable Consent & Releases, and/or not impact a sensitive obstruction. If necessary, and with the approval of the Engineer, reduce the proposed superelevation rate of a curve if the new elevations of the edges of pavement will cause the proposed roadside grading to extend beyond the Right-of-Way, or extend outside of the general area described on any applicable Consent & Releases, and/or impact a sensitive obstruction. Alternatively, with the approval of the Engineer and to the extent allowable by the "Ditching & Shouldering and Embankment Benching Details" and/or the Special Note for Ditching & Shouldering, the Contractor may be allowed to adjust the proposed dimensions of the roadside grading so the new toe of slope or top of cut will remain within the Right-of-Way, or within the general area noted on any applicable Consent & Releases, and/or not impact a sensitive obstruction. After the final proposed elevation changes along the edges of pavement for each curve are determined and before paving operations begin, submit to the Engineer and obtain approval for the number of asphalt lifts, each asphalt lift's thickness, and the mix design of each lift of Leveling & Wedging the contractor plans to use to achieve the proposed superelevation improvement. Ensure positive drainage upon completion of the work.
3. Verify the dimensions, type, and quantities of the culvert pipes, entrance pipes, and/or box culverts as listed and detailed in the proposal, and determine flow line elevations and slopes necessary to provide positive drainage. Revise as necessary to accommodate the existing site conditions; to provide proper alignment of the drainage structures with existing and/or proposed ditches, stream channels, swales, and the roadway lines and grades; and to ensure positive drainage upon completion of the work.
4. Using stakes, paint marks on the pavement, mag nails, and/or any other means approved by the Engineer, the Contractor shall mark and/or stake the proposed sign locations in the field. NOTE: The proposed signs are listed in the proposal by approximate location and are NOT to be taken as the exact location for the signs. During staking operations the Contractor shall review the signing layout and existing field conditions and look for potential conflicts, including but not limited to utilities, driveways, visual obstructions, etc. When conflicts are found, adjust the staked location of signs to mitigate conflicts. Because the sign locations in the proposal are approximate and the location of some signs may need to be adjusted due to conflicts, during staking operations the Contractor shall refer to and utilize the information in the Manual on Uniform on Traffic Control Devices (MUTCD), current edition. The MUTCD cover items such as: appropriate sign location, advance placement distances, and spacing requirements for signing. The intent is for the proposed signs to be consistent with, and meet the requirements of, the MUTCD. Once the proposed sign locations have been staked, notify and coordinate with the District Traffic Engineer, and perform a review of the staked locations. Adjust the staked

Staking
Page 2 of 2

locations, as directed by the District Traffic Engineer and obtain approval of the final staked locations. This review will also be used to determine if there are any existing signs that require removal and/or relocation. Provide the District Traffic Engineer with 2 weeks of notice when a route will be ready for a review of the staked locations. NOTE: The District Traffic Engineer may determine that the proposed signing, including sign types and messages, needs to be adjusted and/or modified from what is shown in the proposal. Therefore, the Contractor shall not order any sign material for a route until the route has been staked and final sign location approval has been given by the District Traffic Engineer.

5. Produce and furnish to the Engineer "As Built" information for the superelevation improvements and the drainage improvements. For superelevation improvements, as built information will consist of a record of the final pavement cross slopes every 50 feet, for each lane of travel along the curves and the transitions into and out of the curves. Elevation data of the curve improvements is not necessary; simply the cross slope percentage every 50 feet. For the drainage improvements, as built information will consist of a final record of the actual types, sizes, and locations of the drainage structures (i.e. box inlets, headwalls, junction boxes, etc.), culvert pipes, and/or box culverts constructed. Final elevation data of the drainage improvements is not necessary.
6. Using paint marks on the pavement, and/or any other means approved by the Engineer, the Contractor shall layout and pre-mark the proposed striping, pavement markings, etc. Adjust as necessary to accommodate the existing site conditions and to provide proper alignment of the proposed thru and turning lanes. Obtain approval of the pre-marked layout from the Engineer and/or District Traffic Engineer prior to installing the striping and/or pavement markings.
7. Prior to incorporating into the work, obtain the Engineers approval of all revisions determined by the Contractor.
8. Perform any and all other staking operations required to control and construct the work.

Special Note for Erosion Control

I. DESCRIPTION

Perform all erosion and water pollution control work in accordance with any other notes in the Proposal, the Department's Standard and Interim Supplemental Specifications, the Special Provisions and Special Notes, and the Standard and Sepia Drawings, current editions, or as directed by the Engineer. Section references are to the Standard Specifications. This work shall consist of:

(1) Developing and preparing a Best Management Practices Plan (BMP) tailored to suit the specific construction phasing for each site within the project; (2) Preparing the project site for construction, including locating, furnishing, installing, and maintaining temporary and/or permanent erosion and water pollution control measures as required by the BMP prior to beginning any earth disturbing activity on the project site; (3) Clearing and grubbing and removal of all obstructions as required for construction; (4) Removing all erosion control devices when no longer needed; (5) Restoring all disturbed areas as nearly as possible to their original condition; (6) Preparing seedbeds and permanently seeding all disturbed areas; (7) Providing a Kentucky Erosion Prevention and Sediment Control Program (KEPSC) qualified inspector; and (8) Performing any other work to prevent erosion and/or water pollution as specified by this contract, required by the BMP, or as directed by the Engineer.

II. MATERIALS

Furnish materials in accordance with these notes, the Standard Specifications and Interim Supplemental Specifications, applicable Special Provisions and Special Notes, and the Standard and Sepia Drawings, current editions. Provide for all materials to be sampled and tested in accordance with the Department's Sampling Manual. Unless directed otherwise by the Engineer, make the materials available for sampling a sufficient time in advance of the use of the materials to allow for the necessary time for testing.

III. CONSTRUCTION

Be advised, these Erosion Control Notes do not constitute a BMP plan for the project. Jointly with the Engineer, prepare a site-specific BMP plan for each drainage area within the project in accordance with Section 213. Provide a unique BMP at each project site using good engineering practices taking into account existing site conditions, the type of work to be performed, the construction phasing, methods, and the techniques to be utilized to complete the work. Be responsible for all erosion prevention, sediment control, and water pollution prevention measures required by the BMP for each site. Represent and warrant compliance with the Clean Water Act (33 USC Section 1251 et seq.), the 404 Permit, the 401 Water Quality Certification, and applicable state and local government agency laws, regulations, rules, specifications, and permits. Contrary to Section 105.05, in case of discrepancy between these notes, the Standard Specifications, Interim Supplemental Specifications, Special Provisions and Special Notes, Standard and Sepia Drawings, and such state and local government agency requirements, adhere to the most restrictive requirement.

Conduct operations in such a manner as to minimize the amount of disturbed ground during each phase of the construction and limit the haul roads to the minimum required to perform the work. Preserve existing

Erosion Control Page 2 of 3

vegetation not required to be removed by the work or the contract. Seed and/or mulch disturbed areas at the earliest opportunity. Use silt fence, silt traps, temporary ditches, brush barriers, erosion control blankets, sodding, channel lining, and other erosion control measures in a timely manner as required by the BMP and as directed or approved by the Engineer. Prevent sediment laden water from leaving the project, entering an existing drainage structure, or entering a stream.

Provide for erosion control measures to be in place and functioning prior to any earth disturbance within a drainage area. Compute the volume and size of silt control devices necessary to control sediment during each phase of construction. All silt control devices shall be sized to retain a volume of 3,600 cubic feet per disturbed contributing acre. Remove sediment from silt traps before they become a maximum of ½ full. Maintain silt fence by removing accumulated trappings and/or replacing the geotextile fabric when it becomes clogged, damaged, or deteriorated, or when directed by the Engineer. Properly dispose of all materials trapped by erosion control devices at approved sites off the right of way obtained by the Contractor at no additional cost to the Department. See the Special Provision for Waste and Borrow Sites.

As work progresses, add or remove erosion control measures as required by the BMP, applicable to the Contractor's project phasing, construction methods, and techniques. Update the volume calculations and modify the BMP as necessary throughout the duration of the project. Ensure that an updated BMP is kept on site and available for public inspection throughout the life of the project.

The required volume at each Silt Trap shall be computed based on the Up Gradient Contributing Areas that are disturbed and/or stabilized to the satisfaction of the Engineer. The required volume calculation for each Silt Trap shall be determined by the Contractor and verified by the Engineer. The required volume at each Silt Trap may be reduced by the following amounts:

- Up Gradient Areas not disturbed (acres)
- Up Gradient Areas that have been reclaimed and protected by Erosion Control Blanket or other ground protection material such as Temporary Mulch (acres)
- Up Gradient Areas that have been protected by Silt Fence (acres) – Areas protected by Silt Fence shall be computed at a maximum rate of 100 square feet per linear foot of Silt Fence
- Up Gradient Areas that have been protected by Silt Traps (acres)

The use of Temporary Mulch is encouraged.

Silt Trap Type B shall always be placed at the collection point prior to discharging into a Blue Line Stream or onto an adjacent Property Owner. Where overland flow exists, a Silt Fence or other filter devices may be used.

After all construction is complete, restore all disturbed areas in accordance with Section 212. Completely remove all temporary erosion control devices not required as part of the permanent erosion control from the construction site. Prior to removal, obtain the Engineer's concurrence of items to be removed. Grade the remaining exposed earth (both on and off the Right-of-Way) as nearly as possible to its original condition, or as directed by the Engineer. Prepare the seed bed areas and sow all exposed earthen areas with the applicable seed mixture(s) according to Section 212.03.03.

Erosion Control
Page 3 of 3

IV. MEASUREMENT

The Department will measure the various erosion control items according to Section 212.04 and Section 213.04, as applicable.

V. Basis of Payment

The Department will make payment for the various erosion control items according to Section 212.04 and Section 213.04, as applicable.

Special Note for Signage

All sign sheeting shall be from the Cabinet's List of Approved Materials.

All permanent signs and sign components shall be fabricated using Type XI sheeting.

The following signs and sign components shall be fabricated using Type XI fluorescent yellow sheeting:

- Horizontal Alignment Signs and Plaques, including signs shown in Figure 2C-1 of the MUTCD
- All Advisory Speed (W13-1P) plaques

The following signs shall be fabricated using Type XI fluorescent yellow-green sheeting:

- School and school bus warning signs, including the fluorescent yellow-green signs shown in Figures 7B-1 and 7B-6 of the MUTCD and other school-related warning signs that are not included in the MUTCD.
- Bicycle Warning (W11-1) signs and SHARE THE ROAD (W16-1P) plaques or diagonal downward pointing arrow (W16-7P) plaques that supplement Bicycle Warning signs.
- Pedestrian Warning signs and diagonal downward pointing arrow plaques that supplement Pedestrian Warning signs.
- In-Street Pedestrian Crossing (R1-6) signs and Overhead pedestrian Crossing (R1-9) signs
- Supplemental plaques to any of the previously listed signs

Special Note for Signing

I. DESCRIPTION

Except as provided herein, this work shall be performed in accordance with the current edition of the Manual on Uniform Traffic Control Devices (MUTCD), the Department's current Standard Specifications and Interim Supplemental Specifications, applicable Standard and Sepia Drawings, and applicable Special Provisions. Article references are to the Standard Specifications. This project shall consist of furnishing all labor, equipment, materials, and incidentals for the following:

(1) Maintaining and Controlling Traffic; (2) Furnish, Fabricate, and Erect Signs; and (3) All other work specified in the Contract.

II. MATERIALS

All materials shall be sampled and tested in accordance with the Department's Sampling Manual and the materials shall be available for sampling a sufficient time in advance of the use of the materials to allow for the necessary time for testing unless otherwise specified in these Notes.

A. Maintain and Control Traffic. See Traffic Control Plan.

B. Erosion Control. See Special Note for Erosion Control.

III. CONSTRUCTION METHODS

A. Maintain and Control Traffic. See Traffic Control Plan.

B. Site Preparation. Be responsible for all site preparation including, but not limited to: clearing and grubbing, staking, excavation, backfill, and removal of obstructions or any other material not covered by other items. Perform all site preparation only as approved or directed by the Engineer.

C. Staking. See Special Note for Staking.

D. Signs and Posts. Before beginning installation, the Contractor shall furnish to the Engineer drawings, descriptions, manufacturer's cuts, etc. covering all material to be used. Mill test reports for beams, steel panels, and each different gauge of aluminum or steel sheeting used must be submitted to the Division of Construction and approved prior to erection.

Fabricate sheet signs from .080 or .125 gauge aluminum alloy 5052-H38 or 6061-T6, in accordance with ASTM B-209, and to the size and shape specified. Prepare the side of the sheet to be used as the sign face to receive the retroreflective background material according to the recommendations of the sheeting and retroreflective material manufacturer(s). Sheeting used as background material for sign faces is to be the color specified and visually in accordance with the standard requirements of ASTM D-4956, and meet the requirements of Section 830 of the Standard Specifications. Contrary to Section 830.02.06, only the types and colors of sheeting as specified in the proposal will be

Signing
Page 2 of 6

accepted. All retroreflective material shall be fabricated and assembled in accordance with the specifications and/or recommendations of the manufacturer(s).

All hardware for the erection of sheeting signs shall be rust resistant: stainless steel, zinc coated, aluminum, or an Engineer approved material. All beams and posts shall be of sufficient lengths to extend from the top of the sign to the required embedment in the anchor. Splicing of the sign post shall NOT be allowed. For installations in soil, Type I steel posts shall be mounted on either a standard anchor, with soil stabilizer plate, or on a Type D breakaway sign support. Refer to Sheeting Sign Detail Sheet 1 of 2 for installation details for a standard anchor with soil stabilizer plate. When installing a standard anchor with soil stabilizer plate, if solid rock is encountered, the Contractor shall drill a hole to the required depth into the rock, install the anchor into the hole, and backfill the anchor post with concrete, or other method approved by the Engineer. The cost shall be incidental to Type I steel post, and a soil stabilizer plate will not be required. Refer to Standard Drawing RGX-065, current edition, for installation details of Type D breakaway sign supports. Approved manufacturers for Type D breakaway sign supports have been placed on the list of approved materials. For installations on existing concrete, such as a sidewalk, concrete median, etc., or installations on existing asphalt, such as flush medians, Type I steel posts shall be mounted on a Type D Surface Mount. For Type D Surface Mounts use only Kleen Break Model 425 by Xcessories Squared of Auburn, IL. If the Surface Mount is to be installed on sufficiently cured concrete, use part number XKBSM42520-G. If the Surface Mount is to be installed on asphalt surface, use part numbers XKB42520-G and AXT225-36-G. Prior to installation, the Contractor shall submit to the Engineer shop drawings of the Type D Surface Mount(s). Install the Type D Surface Mount(s) according to all the applicable requirements of the manufacturer (see shop drawings). All steel post shall meet the requirements of Section 832. All hardware including, but not limited to, sign post anchors, soil stabilizer plates, nuts, bolts, washers, fasteners, fittings, and bracing, or any other incidentals necessary to erect the signs shall be furnished by the Contractor and will be incidental to the work.

New concrete bases, posts, support anchors, signs, etc. are to be installed prior to dismantling any existing sign(s). The removal of existing signs, posts, and support anchors is to be performed concurrently with the installation of new signs, posts, and support anchors, under the same lane closure during the same work shift. Completely remove existing sign support anchors or remove them to a minimum depth of six (6) inches below existing ground line and backfill the disturbed area to the existing ground line.

When listed in the summaries, Reflective Sign Post Panels shall be 2" wide x 60" tall (or 84" tall for urban installations) and shall have three 3/8" holes (one hole in the top 3", one hole near the center, and one hole in the bottom 3") that align with the holes on the Type I steel post. Sheeting for the Reflective Sign Post Panels shall be the same Type and color as the sign installed on the post. Examples include:

- Red, fluorescent yellow, and fluorescent yellow-green (Type XI Sheeting)
- White and yellow (Type XI Sheeting).

All manufactured sheeting signs shall be free of visual defects including, but not limited to: cracks, tears, ridges, humps, discoloration, etc., and defective signs shall be replaced at no additional cost to the Department.

Signing
Page 3 of 6

All sign blanks shall be hole punched by the manufacturer for either horizontal or vertical installation. Attach all aluminum sheeting signs to square post with 3/8" all steel rivets and nylon washers.

Post will be attached to the anchor with 5/16" corner bolts and 5/16" flanged nuts, and all post and anchor cuts shall be treated with a Cold Galvanizing Compound spray.

Sign posts shall be erected vertically by using a bubble level. The tolerance shall be a two (2) degree angle in any direction. For locations where more than one sign is mounted beside each other, the posts shall be spaced to provide approximately six inches (6") of spacing between signs.

- E. Property Damage.** The Contractor shall be responsible for all damage to public and/or private property resulting from the Contractor's activities. Repair or replace damaged roadway features in like kind materials and design as directed by the Engineer at no additional cost to the Department. Repair or replace damaged private property in like kind materials and design to the satisfaction of the owner and the Engineer at no additional cost to the Department.
- F. Coordination with Utility Companies.** Locate all underground, above ground, and overhead utilities prior to beginning construction. Be responsible for contacting and maintaining liaison with all utility companies that have utilities located within the project limits. Do not disturb existing overhead or underground utilities. It is not anticipated that any utility facilities will need to be relocated and/or adjusted; however, in the event that it is discovered that the work does require that utilities be relocated and/or adjusted, the utility companies will work concurrently with the Contractor while relocating their facilities. Be responsible for repairing all utility damage that occurs due to the Contractor's operations at no additional cost to the Department. NOTIFY THE ENGINEER AND THE UTILITY OWNER(S) IMMEDIATELY WHEN IT IS DISCOVERED OR ANTICIPATED THAT ANY UTILITY CONFLICT COULD DELAY THE CONTRACTOR'S OPERATIONS. If the total delay exceeds ten working days, an extension of the specified completion date will be negotiated with the Contractor for delay to the Contractor's work; however, no extension will be granted for any delay caused by the Contractor's failure to notify the Engineer and/or the utility company as specified above when a conflict is discovered or anticipated as specified.
- G. Caution.** The information in this proposal and the type of work listed herein are approximate only and are not to be taken as an exact evaluation of the materials and conditions to be encountered during construction; the bidder must draw his/her own conclusions when developing the Unit Bid Prices for each bid item. As such, if the conditions encountered are not in accordance with the information shown, the Department does not guarantee any changes to the Unit Bid Prices nor extension of the contract will be considered. The Department will pay for bid item quantity overruns, but only if pre-approved by the Engineer.
- H. Control.** Perform all work under the absolute control of the Department. Obtain the Engineer's approval of all designs required to be furnished by the Contractor prior to incorporation into the work. The Department reserves the right to have other work performed by other contractors and its own forces, and to permit public utility companies and others to do work during the construction within the limits of, or adjacent to, the project. Conduct operations and cooperate with such other parties so that interference with such other work will be reduced to a minimum. The Department

Signing
Page 4 of 6

will not honor any claims for money or time extension created by the operations of such other parties.

Should a difference of opinion arise as to the rights of the Contractor and others working within the limits of, or adjacent to, the project, the Engineer will decide as to the respective rights of the various parties involved in order to assure the completion of the Department's work in general harmony and in a satisfactory manner, and the Engineer's decision shall be final and binding upon the Contractor.

- I. **Clean Up, Disposal of Waste.** Clean up the project area as work progresses. Dispose of all removed concrete, debris, and other waste as per Section 204.03.08. The Department will incur no cost to obtain the disposal sites. The Department will NOT make direct payment for disposal of waste and debris from the project. Existing anchors, signs, posts, and any other hardware or material removed from the site are to become the property of the Contractor. See Special Provision for Waste and Borrow Sites.
- J. **Final Dressing, Seeding and Protection.** Grade all disturbed areas to blend with the adjacent roadways features and to provide a suitable seed bed. Apply Class A Final Dressing to all disturbed areas, both on and off the Right-of-Way. Sow all disturbed earthen areas with the applicable seed mixture(s) according to Section 212.03.03.
- K. **Erosion Control.** See Special Note for Erosion Control.

IV. METHOD OF MEASUREMENT

- A. **Maintain and Control Traffic.** See Traffic Control Plan.
- B. **Site Preparation.** Other than the bid items listed, the Department will NOT measure Site Preparation for payment, but shall be incidental to the project bid items.
- C. **Signs.** The Department will measure the finished in-place area of signs in Square Feet.
- D. **Sign Posts.** The Department will measure the finished in-place length of sign posts in Linear Feet, from the top of the anchor, or top of the sign support, to the top of the sign post. Laps, cutoffs, excess, and waste will NOT be measured for payment.
- E. **Type D Breakaway Sign Supports.** The Department will measure Type D sign supports as Each support installed.
- F. **Type D Surface Mounts.** The Department will measure Type D Surface Mounts as Each surface mount installed.
- G. **Class A Concrete for Signs.** The Department will measure the Class A Concrete used in conjunction with Type D breakaway sign support installations in Cubic Yards. Any concrete that is required as backfill due to hitting rock during a standard installation shall be incidental to the bid item STEEL POST TYPE I, and soil stabilizers will not be required.

Signing
Page 5 of 6

- H. Clean Up, Disposal of Waste, Final Dressing, Seeding and Protection.** The Department will NOT measure for payment the following activities: Clean Up, Disposal of Waste, and Final Dressing. These activities shall be incidental. Seeding and Protection shall be measured according to Section 212.
- I. Erosion Control.** See Special Note for Erosion Control.
- J. Remove Sign.** The Department will consider all signs attached to one or more connected posts as a single sign. The Department will measure as Each sign assembly removed and NOT each individual sign removed.
- K. Items Provided by KYTC.** The Department will NOT measure for payment the installation of signs and/or surface mounts provided by KYTC. These activities shall be incidental to the bid item STEEL POST TYPE I.

V. BASIS OF PAYMENT

- A. Maintain and Control Traffic.** See Traffic Control Plan.
- B. Signs.** The Department will make payment for the completed and accepted quantities under the bid item SBM ALUM SHEET SIGNS .125 IN or .080 IN. The Department will consider payment full compensation for all work and incidentals necessary to install the signs, as required by these notes and the details found elsewhere in the proposal, at the locations indicated on the summary sheets, plans, and/or as directed by the Engineer.
- C. Sign Posts.** The Department will make payment for the completed and accepted quantities under the bid item STEEL POST TYPE I. The Department will consider payment full compensation for all work and incidentals necessary to install the sign posts as required by these notes and the details found elsewhere in the proposal.
- D. Type D Breakaway Sign Supports.** The Department will make payment for the completed and accepted quantities under the bid item GMSS TYPE D. The Department will consider payment full compensation for all work and incidentals necessary to install the Type D breakaway sign supports as required by Standard Drawing RGX-065, current edition.
- E. Type D Surface Mounts.** The Department will make payment for the completed and accepted quantities under the bid item GMSS TYPE D (SURFACE MOUNT). The Department will consider payment full compensation for all work and incidentals necessary to install the Type D surface mounts according to all applicable manufacturer requirements.
NOTE: The permissible Type D Surface Mount alternative is: Kleen Break Model 425 for Surface Mount Concrete Installations by Xcessories Squared of Auburn, IL
- F. Class A Concrete for Signs.** The Department will make payment for the completed and accepted quantities, used in conjunction with Type D breakaway sign support installations, under the bid item CLASS A CONCRETE FOR SIGNS. The Department will consider payment full compensation for all work

Signing
Page 6 of 6

and incidentals necessary to install the concrete as required by Standard Drawing RGX-065, current edition.

- G. Remove Sign.** The Department will make payment for the completed and accepted quantities under the bid item REMOVE SIGN. The Department will consider payment full compensation for all work and incidentals necessary to remove the existing signs, posts, anchors, and any other sign material or hardware, from the locations indicated on the summary sheets, plans, and/or as directed by the Engineer.

- H. Erosion Control.** See Special Note for Erosion Control.

Special Note for Completion Date & Liquidated Damages

I. COMPLETION DATE

The ultimate fixed completion date for this project will be November 15, 2022. Liquidated Damages for failure to complete the project on time will be assessed following Section 108.09.

II. LIQUIDATED DAMAGES

In addition to the requirements of Section 108.09, the Department will assess Liquidated Damages in the amount of **\$1,000** per hour for each hour, or fraction of an hour, for any and all lane closures that are in place beyond the time frame(s) noted in the Traffic Control Plan and approved by the Engineer.

Contrary to Section 108.09, Liquidated Damages will be assessed regardless of whether seasonal limitations prohibit the Contractor from performing work on the controlling operation.

NOTE: At the sole discretion of the Engineer, all, or part, of these Liquidated Damages may be waived due to unforeseen circumstances, such as unexpected weather.

Contrary to Section 108.09, Liquidated Damages will be assessed for the months of December through March.

All liquidated damages will be applied accumulatively.

All other applicable portions of Section 108 apply.

SPECIAL PROVISION FOR WASTE AND BORROW SITES

Obtain U.S. Army Corps of Engineer's approval before utilizing a waste or borrow site that involves "Waters of the United States". The Corps of Engineers defines "Waters of the United States" as perennial or intermittent streams, ponds or wetlands. The Corps of Engineers also considers ephemeral streams, typically dry except during rainfall but having a defined drainage channel, to be jurisdictional waters. Direct questions concerning any potential impacts to "Waters of the United States" to the attention of the appropriate District Office for the Corps of Engineers for a determination prior to disturbance. Be responsible for any fees associated with obtaining approval for waste and borrow sites from the U.S. Army Corps of Engineer or other appropriate regulatory agencies.

1-296 Waste & Borrow Sites
01/02/2012

COORDINATION OF WORK WITH OTHER CONTRACTS

Be advised, there may be an active project(s) adjacent to or within this project. The Engineer will coordinate the work of the Contractors. See Section 105.06.

1-3193 Coordination Contracts
01/02/2012

SPECIAL NOTE FOR TYPICAL SECTION DIMENSIONS

Consider the dimensions shown on the typical sections for pavement and shoulder widths and thickness' to be nominal or typical dimensions. The Engineer may direct or approve varying the actual dimensions to be constructed to fit existing conditions. Do not widen existing pavement or shoulders unless specified elsewhere in this proposal or directed by the engineer.

1-3725 Typical Section Dimensions
01/02/2012

TRAFFIC CONTROL PLAN

TRAFFIC CONTROL GENERAL

Except as provided herein, traffic shall be maintained in accordance with the current editions of the Manual on Uniform Traffic Control Devices (MUTCD), Standard Specifications, Supplemental Specifications, and the Standard and Sepia Drawings. Except for the roadway and traffic control bid items listed, all items of work necessary to maintain and control traffic shall be paid at the lump sum bid price to "Maintain and Control Traffic".

Contrary to Section 106.01, traffic control devices used on this project may be new, or used in like new condition, at the beginning of the work and maintained in like new condition until completion of the work. Any temporary traffic control items, devices, materials, and incidentals shall remain the property of the contractor unless otherwise addressed, when no longer needed.

PROJECT PHASING & CONSTRUCTION PROCEDURES

Maintain alternating one-way traffic during construction. Provide a minimum clear lane width of 10 feet; however, provide for passage of vehicles of up to 16 feet in width. If traffic should be stopped due to construction operations, and a school bus or emergency vehicle on an official run arrives on the scene, make provisions for the passage of the school bus or emergency vehicle as quickly as possible.

Take these restrictions into account in submitting bid. The Department will not consider any claims for money or grant contract time extensions for any delays to the Contractor as a result of these restrictions.

Unless otherwise approved by the Engineer, no lane closures will be allowed during the following times:

Memorial Day Weekend	3 pm Friday, May 27, 2022 – 8 pm Monday, May 30, 2022
Independence Day	7 am Saturday, July 2, 2022 – 11 pm Monday, July 4, 2022
Labor Day Weekend	3 pm Friday, September 2, 2022 – 8 pm Monday, September 5, 2022
Thanksgiving Holiday	3 pm Wednesday, November 23, 2022 – 8 pm Sunday, November 27, 2022
Christmas Holiday	3 pm Friday, December 23, 2022 – 8 pm Sunday, December 25, 2022
New Year's Day Holiday	7 am Saturday, December 31, 2022 – 8 pm Sunday, January 1, 2023

At the discretion of the Engineer, additional days and hours may be specified when lane closures will not be allowed.

The Contractor shall submit proposed lane closure days and times to the Engineer at least 14 calendar days in advance for approval. Liquidated Damages will be assessed for each hour or fraction of an hour that a lane closure is in place outside of an approved time period. See the Special Notes for Completion Dates & Liquidated Damages for details on the Liquidated Damages amount.

LANE CLOSURES

Long term lane closures shall not be allowed; therefore, lane closures will not be measured for payment. Do not leave lane closures in place during non-working hours and prohibited periods

Traffic Control Plan
Page 2 of 8

TEMPORARY SIGNS

Temporary signposts and splices shall be compliant with NCHRP 350 or MASH. Manufacturer's documentation validating this compliance shall be provided to the Engineer prior to installation. Temporary signs, including any splices, shall be installed according to manufacturer's specifications and installation recommendations. Contrary to section 112.04.02, only long-term temporary signs (temporary signs intended to be continuously in place for more than 3 days) will be measured for payment. Short-term temporary signs (temporary signs intended to be left in place for 3 days or less) will not be measured for payment but will be incidental to Maintain and Control Traffic.

CHANGEABLE MESSAGE SIGNS

Provide changeable message signs at locations determined by the Engineer. The Engineer may vary the designated locations as the work progresses. The Engineer will determine the messages to be displayed. In the event of damage or mechanical/electrical failure, repair or replace the Changeable Message Sign within 8 hours. The Department will measure for payment the maximum number of Changeable Message Signs in concurrent use at the same time on a single day on all sections of the contract. The Department will measure individual Changeable Message Signs only once for payment, regardless of how many times they are set, reset, removed, and relocated during the duration of the project. The Department will not measure for payment any replacements for damaged Changeable Message Signs or any changeable message signs the Engineer directs to be replaced due to poor condition or readability. Retain possession of the Changeable Message Signs upon completion of the work.

BARRICADES

The Department will not measure barricades used in lieu of barrels and cones for channelization or delineation but shall be incidental to Maintain and Control Traffic according to Section 112.04.01.

TEMPORARY ENTRANCES

The Engineer will not require the Contractor to provide continuous access to farms, single family, duplex, or triplex residential properties during working hours; however, provide reasonable egress and ingress to each such property when actual operations are not in progress at that location. Limit the time during which a farm or residential entrance is blocked to the minimum length of time required for actual operations, not extended for the Contractor's convenience, and in no case exceeding six (6) hours. Notify all residents twenty-four hours in advance of any driveway or entrance closings and make any accommodations necessary to meet the access needs of disabled residents.

Except as allowed by the Phasing as specified above, maintain direct access to all side streets and roads, schools, churches, commercial properties, and apartments or apartment complexes of four or more units at all times. Access to fire hydrants must also be maintained at all times

Traffic Control Plan
Page 3 of 8

TRAFFIC SIGNAL LOOPS

Install traffic signal loops according to the Special Notes for Traffic Signal Loop Replacement. Coordinate the placement of the loops with the Engineer.

THERMOPLASTIC INTERSECTION MARKINGS

Consider the locations listed on the summary and/or shown on the plan sheets as approximate only. Prior to milling and/or resurfacing, locate and document the locations of the existing markings. After final surfacing operations, replace the markings at their approximate existing locations, as shown on the plan sheets, or as directed by the Engineer. Place markings not existing prior to resurfacing as shown on the plan sheets or as directed by the Engineer.

PAVEMENT MARKINGS

If there is to be a deviation from the existing striping plan, the Engineer will furnish the Contractor a striping plan prior to placement of the final surface course.

PAVEMENT EDGE DROP-OFFS

Do not allow a pavement edge between opposing directions of traffic or lanes that traffic is expected to cross in a lane change situation with an elevation difference greater than 1½". Place Warning signs (MUTCD W8-11 or W8-9A) in advance of and at 1500' intervals throughout the drop-off area. Dual post the signs on both sides of the traveled way. Wedge all transverse transitions between resurfaced and un-resurfaced areas which traffic may cross with asphalt mixture for leveling and wedging. Remove the wedges prior to placement of the final surface course.

Protect pavement edges that traffic is not expected to cross, except accidentally, as follows:

Less than 2" - No protection required.

2" to 4" - Place plastic drums, vertical panels, or barricades every 50 feet. During daylight working hours only, the Engineer will allow the Contractor to use cones in lieu of plastic drums, panels, and barricades. Wedge the drop-off with DGA or asphalt mixture for leveling and wedging with a 1:1 or flatter slope in daylight hours, or 3:1 or flatter slope during nighttime hours, when work is not active in the drop-off area.

Greater than 4" - Protect drop-offs greater than 4 inches within 10 feet of traffic by placing drums, vertical panels, or barricades every 25 feet. The Engineer will not allow the use of cones in lieu of drums, vertical panels, or barricades for drop-offs greater than 4". Place Type III Barricades directly in front of the drop-off facing oncoming traffic in both directions of travel. Provide warning signs as shown on the Standard Drawings or as directed by the Engineer

Pedestrians & Bicycles - Protect pedestrian and bicycle traffic as directed by the Engineer.

USE AND PLACEMENT OF CHANGEABLE MESSAGE SIGNS

The following policy is based upon current Changeable Message Signs (CMS) standards and practice from many sources, including the Federal Highway Administration (FHWA), other State Departments of Transportation, and Traffic Safety Associations. It is understood that each CMS installation or use requires individual consideration due to the specific location or purpose. However, there will be elements that are constant in nearly all applications. Accordingly, these recommended guidelines bring a level of uniformity, while still being open to regional experience and engineering judgment.

Application

The primary purpose of CMS is to advise the driver of unexpected traffic and routing situations. Examples of applications where CMS can be effective include:

- Closures (road, lane, bridge, ramp, shoulder, interstate)
- Changes in alignment or surface conditions
- Significant delays, congestion
- Construction/maintenance activities (delays, future activities)
- Detours/alternative routes
- Special events with traffic and safety implications
- Crash/incidents
- Vehicle restrictions (width, height, weight, flammable)
- Advance notice of new traffic control devices
- Real-time traffic conditions (must be kept up to date)
- Weather /driving conditions, environmental conditions, Roadway Weather Information Systems
- Emergency Situations
- Referral to Highway Advisory Radio (if available)
- Messages as approved by the County Engineer's Office

CMS should not be used for:

- Replacement of static signs (e.g. ROAD WORK AHEAD), regulatory signage (e.g. speed limits), pavement markings, standard traffic control devices, conventional warning or guide signs.
- Replacement of lighted arrow board
- Advertising (Don't advertise the event unless clarifying "action" to be taken by driver – e.g. Speedway traffic next exit)
- Generic messages
- Test messages (portable signs only)
- Describe recurrent congestion (e.g. rush hour)
- Public service announcements (not traffic related)

Traffic Control Plan
Page 5 of 8

Messages

Basic principles that are important to providing proper messages and ensuring the proper operation of a CMS are:

- Visible for at least ½ mile under ideal daytime and nighttime conditions
- Legible from all lanes a minimum of 650 feet
- Entire message readable twice while traveling at the posted speed
- No more than two message panels should be used (three panels may be used on roadways where vehicles are traveling less than 45 mph). A panel is the message that fits on the face of the sign without flipping or scrolling.
- Each panel should convey a single thought; short and concise
- Do not use two unrelated panels on a sign
- Do not use the sign for two unrelated messages
- Should not scroll text horizontally or vertically
- Should not contain both the words left and right
- Use standardized abbreviations and messages
- Should be accurate and timely
- Avoid filler/unnecessary words and periods (hazardous, a, an, the)
- Avoid use of speed limits
- Use words (not numbers) for dates

Placement

Placement of the CMS is important to ensure that the sign is visible to the driver and provides ample time to take any necessary action. Some of the following principles may only be applicable to controlled access roadways. The basic principles of placement for a CMS are:

- When 2 signs are needed, place on same side of roadway and at least 1,000 feet apart
- Place behind semi-rigid/rigid protection (guardrail, barrier) or outside of the clear zone
- Place 1,000 feet in advance of work zone; at least one mile ahead of decision point
- Normally place on right side of roadway; but should be placed closest to the affected lane so that either side is acceptable
- Signs should not be dual mounted (one on each side of roadway facing same direction)
- Point trailer hitch downstream
- Secure to immovable object to prevent theft (if necessary)
- Do not place in sags or just beyond crest
- Check for reflection of sun to prevent the blinding of motorist
- Should be turned ~3 degrees outward from perpendicular to the edge of pavement
- Bottom of sign should be 7 feet above the elevation of edge of roadway
- Should be removed when not in use

Traffic Control Plan
 Page 6 of 8

Standard Abbreviations

The following is a list of standard abbreviations to be used on CMS:

<u>Word</u>	<u>Abbrev</u>	<u>Example</u>
Access	ACCS	CRASH AHEAD/ USE ACCS RD NEXT RIGHT
Alternate	ALT	CRASH AHEAD/ USE ALT RTE NEXT RIGHT
Avenue	AVE	FIFTH AVE CLOSED/ DETOUR NEXT LEFT
Blocked	BLKD	FIFTH AVE BLKD/ MERGE LEFT
Boulevard	BLVD	MAIN BLVD CLOSED/ USE ALT RTE
Bridge	BRDG	SMITH BRDG CLOSED/ USE ALT RTE
Cardinal Directions	N, S, E, W	N I75 CLOSED/ DETOUR EXIT 30
Center	CNTR	CNTR LANE CLOSED/ MERGE LEFT
Commercial	COMM	OVRSZ COMM VEH/ USE I275
Condition	COND	ICY COND POSSIBLE
Congested	CONG	HVY CONG NEXT 3 MI
Construction	CONST	CONST WORK AHEAD/ EXPECT DELAYS
Downtown	DWNTN	DWNTN TRAF USE EX 40
Eastbound	E-BND	E-BND I64 CLOSED/ DETOUR EXIT 20
Emergency	EMER	EMER VEH AHEAD/ PREPARE TO STOP
Entrance, Enter	EX, EXT	DWNTN TRAF USE EX 40
Expressway	EXPWY	WTRSN EXPWY CLOSED/ DETOUR EXIT 10
Freeway	FRWY, FWY	GN SYNDR FWY CLOSED/ DETOUR EXIT 15
Hazardous Materials	HAZMAT	HAZMAT IN ROADWAY/ ALL TRAF EXIT 25
Highway	HWY	CRASH ON AA HWY/ EXPECT DELAYS
Hour	HR	CRASH ON AA HWY/ 2 HR DELAY
Information	INFO	TRAF INFO TUNE TO 1240 AM
Interstate	I	E-BND I64 CLOSED/ DETOUR EXIT 20
Lane	LN	LN CLOSED MERGE LEFT
Left	LFT	LANE CLOSED MERGE LFT
Local	LOC	LOC TRAF USE ALT RTE
Maintenance	MAINT	MAINT WRK ON BRDG/ SLOW
Major	MAJ	MAJ DELAYS I75/ USE ALT RTE
Mile	MI	CRASH 3 MI AHEAD/ USE ALT RTE
Minor	MNR	CRASH 3 MI MNR DELAY
Minutes	MIN	CRASH 3 MI/ 30 MIN DELAY
Northbound	N-BND	N-BND I75 CLOSED/ DETOUR EXIT 50
Oversized	OVRSZ	OVRSZ COMM VEH/ USE I275 NEXT RIGHT
Parking	PKING	EVENT PKING NEXT RGT
Parkway	PKWY	CUM PKWAY TRAF/ DETOUR EXIT 60
Prepare	PREP	CRASH 3 MI/ PREP TO STOP
Right	RGT	EVENT PKING NEXT RGT
Road	RD	HAZMAT IN RD/ ALL TRAF EXIT 25
Roadwork	RDWK	RDWK NEXT 4 MI/ POSSIBLE DELAYS
Route	RTE	MAJ DELAYS I75/ USE ALT RTE
Shoulder	SHLDR	SHLDR CLOSED NEXT 5 MI
Slippery	SLIP	SLIP COND POSSIBLE/ SLOW SPD
Southbound	S-BND	S-BND I75 CLOSED/ DETOUR EXIT 50
Speed	SPD	SLIP COND POSSIBLE/ SLOW SPD

Traffic Control Plan
 Page 7 of 8

Standard Abbreviations (cont.)

<u>Word</u>	<u>Abbrev</u>	<u>Example</u>
Street	ST	MAIN ST CLOSED/ USE ALT RTE
Traffic	TRAF	CUM PKWAY TRAF/ DETOUR EXIT 60
Vehicle	VEH	OVRSZ COMM VEH/ USE I275 NEXT RIGHT
Westbound	W-BND	W-BND I64 CLOSED/ DETOUR EXIT 50
Work	WRK	CONST WRK 2MI/ POSSIBLE DELAYS

Certain abbreviations are prone to inviting confusion because another word is abbreviated or could be abbreviated in the same way. DO NO USE THESE ABBREVIATIONS:

<u>Abbrev</u>	<u>Intended Word</u>	<u>Word Erroneously Given</u>
ACC	Accident	Access (Road)
CLRS	Clears	Colors
DLY	Delay	Daily
FDR	Feeder	Federal
L	Left	Lane (merge)
LOC	Local	Location
LT	Light (traffic)	Left
PARK	Parking	Park
POLL	Pollution (index)	Poll
RED	Reduce	Red
STAD	Stadium	Standard
TEMP	Temporary	Temperature
WRNG	Warning	Wrong

Typical Messages

The following is a list of typical messages used on CMS. The list consists of the reason or problem that you want the driver to be aware of and the action that you want the driver to take.

<u>Reason/Problem</u>	<u>Action</u>
CRASH AHEAD	ALL TRAFFIC EXIT RT
CRASH/XX MILES	AVOID DELAY USE XX
XX ROAD CLOSED	CONSIDER ALT ROUTE
XX EXIT CLOSED	DETOUR
BRIDGE CLOSED	DETOUR XX MILES
BRIDGE/(SLIPPERY, ICE, ETC.)	DO NOT PASS
CENTER/LANE/CLOSED	EXPECT DELAYS
DELAY(S), MAJOR/DELAYS	FOLLOW ALT ROUTE
DEBRIS AHEAD	KEEP LEFT
DENSE FOG	KEEP RIGHT
DISABLED/VEHICLE	MERGE XX MILES
EMER/VEHICLES/ONLY	MERGE LEFT
EVENT PARKING	MERGE RIGHT
EXIT XX CLOSED	ONE-WAY TRAFFIC
FLAGGER XX MILES	PASS TO LEFT

Traffic Control Plan
Page 8 of 8

Typical Messages (cont.)

Reason/Problem

FOG XX MILES
FREEWAY CLOSED
FRESH OIL
HAZMAT SPILL
ICE
INCIDENT AHEAD
LANES (NARROW, SHIFT, MERGE, ETC.)
LEFT LANE CLOSED
LEFT LANE NARROWS
LEFT 2 LANES CLOSED
LEFT SHOULDER CLOSED
LOOSE GRAVEL
MEDIAN WORK XX MILES
MOVING WORK ZONE, WORKERS IN ROADWAY
NEXT EXIT CLOSED
NO OVERSIZED LOADS
NO PASSING
NO SHOULDER
ONE LANE BRIDGE
PEOPLE CROSSING
RAMP CLOSED
RAMP (SLIPPERY, ICE, ETC.)
RIGHT LANE CLOSED
RIGHT LANE NARROWS
RIGHT SHOULDER CLOSED
ROAD CLOSED
ROAD CLOSED XX MILES
ROAD (SLIPPERY, ICE, ETC.)
ROAD WORK
ROAD WORK (OR CONSTRUCTION) (TONIGHT, TODAY, TOMORROW, DATE)
ROAD WORK XX MILES
SHOULDER (SLIPPERY, ICE, SOFT, BLOCKED, ETC.)
NEW SIGNAL XX MILES
SLOW 1 (OR 2) - WAY TRAFFIC
SOFT SHOULDER
STALLED VEHICLES AHEAD
TRAFFIC BACKUP
TRAFFIC SLOWS
TRUCK CROSSING
TRUCKS ENTERING
TOW TRUCK AHEAD
UNEVEN LANES
WATER ON ROAD
WET PAINT
WORK ZONE XX MILES
WORKERS AHEAD

Action

PASS TO RIGHT
PREPARE TO STOP
REDUCE SPEED
SLOW
SLOW DOWN
STAY IN LANE
STOP AHEAD
STOP XX MILES
TUNE RADIO 1610 AM
USE NN ROAD
USE CENTER LANE
USE DETOUR ROUTE
USE LEFT TURN LANE
USE NEXT EXIT
USE RIGHT LANE
WATCH FOR FLAGGER

SPECIAL NOTE FOR TRAFFIC SIGNAL LOOP DETECTORS

1.0 DESCRIPTION. Be advised that there are existing traffic signal loop detectors within the construction limits of this project. Except as specified herein, perform traffic signal loop replacement in accordance with the Department's Standard/Supplemental Specifications, Special Provisions, Special Notes, and Standard/Sepia Drawings, current editions and as directed by the Engineer. Article references are to the Standard Specifications. Furnish all materials, labor, equipment, and incidentals for replacement of traffic signal loop installation(s) and all other work specified as part of this contract.

1.1 Pre-bid Requirements. Conform to Subsection 723.03.17

2.0 MATERIALS. Except as specified herein, furnish materials in accordance with Subsection 732.02 and Section 835. Provide for materials to be sampled and tested in accordance with the Department's Sampling Manual. Make materials available for sampling a sufficient time in advance of the use of the materials to allow for the necessary time for testing, unless otherwise specified in this Special Note.

2.1 Maintain and Control Traffic. See Traffic Control Plan.

2.2 Sand. Furnish natural sand meeting the requirements of Subsection 804.04.01.

2.3 Seeding. Furnish Seed Mix Type I.

2.4 Loop Saw Slot and Fill. Furnish loop sealant, backer rod, and non-shrink grout according to the Saw Slot Detail.

2.5 Junction Boxes. Furnish junction box type B, #57 aggregate, and geotextile filter type IV according to junction box detail.

2.6 Cable No. 14/1 Pair (Lead-in). Furnish cable that is specified in Section 835. Cable shall be ran splice free. This shall include splice kits to connect to the loop wire.

2.7 Conduit. Furnish and install appropriate conduit from transitions to the roadway, junction boxes and poles. See details below.

3.0 CONSTRUCTION. Except as specified herein, install and test Traffic Signal Loop Detectors in accordance with Section 723 and the drawings.

3.1 Testing. Conform to Subsection 723.03.17 (A)

3.2 Coordination. Conform to Subsection 723.03.17 (B)

3.3 Connection. Conform to Subsection 723.03.17 (C)

3.4 Maintain and Control Traffic. See Traffic Control Plan.

3.5 Milling. Conform to Subsection 723.03.17 (F)

3.6 Loop Saw Slot and Fill. Conform to Subsection 723.03.13 (A).

Traffic Signal Loop Detectors
Page 2 of 9

3.7 Backfilling and Disturbed Areas. Conform to Subsection 723.03.11.

3.8 Removal. Conform to Subsection 723.03.16.

3.9 Property/Roadway Damage. Conform to Subsection 723.03.17 (J).

3.10 Right-of-Way Limits. Conform to Subsection 723.03.17 (K).

3.11 Utility Clearance. Conform to Subsection 716.03.01.

3.12 Control. Obtain the Engineer's approval of all designs required to be furnished by the Contractor prior to incorporation into the work. The Department reserves the right to permit other contractors, state forces, public utility companies, and others to do work during the construction within the limits of, or adjacent to, the project. Conduct operations and cooperate with such other parties so that interference with each other's work will be reduced to a minimum. The Contractor agrees to make no claims against the Department for additional compensation due to delays or other conditions created by the operations of such other parties. Should a difference of opinion arise as to the rights of the Contractor and others working within the limits of, or adjacent to, the project, the Engineer will decide as to the respective rights of the various parties involved in order to ensure the completion of the work in general harmony and in a satisfactory manner, and the Engineer's decision shall be final and binding upon the Contractor.

3.13 Bore and Jack. Conform to Subsection 723.03.06 (I).

3.14 Open Cut Roadway. Conform to Subsection 723.03.06 (I).

4.0 MEASUREMENT. See Subsection 723.04 for bid item notes. Additional bid items include the following:

4.1 Loop Test. The Department will measure the quantity as each individual unit loop tested. The Department will not measure disconnection, reconnection, traffic control, re-splicing per specifications, before and after testing per note above, and any associated hardware for payment and will consider them incidental to this item of work.

4.2 Remove Signal Equipment. The department will measure the quantity by each. The department will not measure backfilling and the disposal or transportation of equipment and materials associated with any structural or electrical component of the signal system including, but not limited to pole bases, poles, junction boxes, cabinets, and wood poles for payment and will consider them incidental to this item of work.

5.0 PAYMENT. The Department will make payment for the completed and accepted quantities of listed items according to Subsection 723.05 in addition to the following:

<u>Code</u>	<u>Pay Item</u>	<u>Pay Unit</u>
Conduit 1"	4792	Linear Foot
PVC Conduit – 1 ¼ inch – sch 80	24900EC	Linear Foot

Traffic Signal Loop Detectors
Page 3 of 9

PVC Conduit – 2 inch – sch 80	24901EC	Linear Foot
Conduit 2”	4795	Linear Foot
Electrical Junction Box type B	4811	Each
Loop Test	24963ED	Each
Trenching and Backfilling	4820	Linear Foot
Loop Wire	4830	Linear Foot
Cable-No. 14/1 Pair	4850	Linear Foot ¹
Loop Saw Slot and Fill	4895	Linear Foot ¹
Bore and Jack Conduit	21543EN	Linear Foot ³
Open Cut Roadway	4821	Linear Foot ³
Remove Signal Equipment	24955ED	each

The Department will consider payment as full compensation for all work required under these notes and the Standard Specifications.

Contrary to section 723:

SUBSECTION: 03.13 Loop Installation.

REVISION: Replace first sentence note with the following:

twist unshielded loop wire (imsa 51-7) with 3 to 5 turns from the start of homerun to the inside conduit, junction box, cabinet, or pole. Twist unshielded loop wires (imsa 51-7) with 3 to 5 turns per foot from the start of the homerun to the junction box, cabinet, or pole. Slot can be widen to .5" to .625" to help with the installation of the twisted wire.

Traffic Signal Loop Detectors

Page 4 of 9

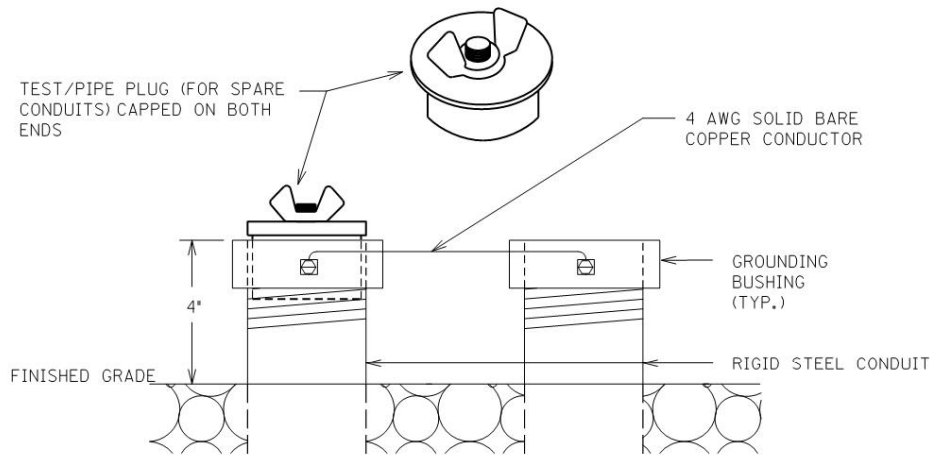

TEST/PIPE PLUG(FOR SPARE CONDUITS) AND GROUNDING DETAIL

Traffic Signal Loop Detectors
Page 5 of 9

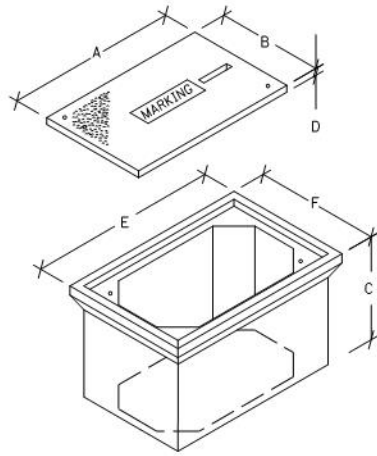

JUNCTION BOX DIMENSIONS (NOMINAL)						
	A	B	C	D	E	F
TYPE A	23"	14"	27"	2"	25"	15"
TYPE B	18"	11"	12"	1 3/4"	20"	13"
TYPE C	36"	24"	30"	3"	38"	26"

• MINIMUM
NOTE: STACKABLE BOXES ARE PERMITTED

BEFORE THE INSTALLATION OF THE #57 AGGREGATE AND JUNCTION BOX, THE CONTRACTOR SHALL INSTALL GEOTEXTILE FILTER FABRIC TYPE IV IN THE HOLE. THE FABRIC SHALL EXTEND TO JUST BELOW THE LIP OF THE JUNCTION BOX AND SHALL BE CONTINUOUSLY ADHERED TO THE EXTERIOR OF THE BOX WITH ADHESIVE. ANY LOCATIONS WHERE CONDUITS ENTER THE BOX, THE FABRIC SHALL BE 'X CUT' ONLY AS MUCH AS NECESSARY TO ALLOW PASSAGE OF EACH INDIVIDUAL CONDUIT THROUGH THE FABRIC. THE FABRIC SHALL BE INCIDENTAL TO BID ITEMS 481I, 2039INS835, OR 20392NS835.

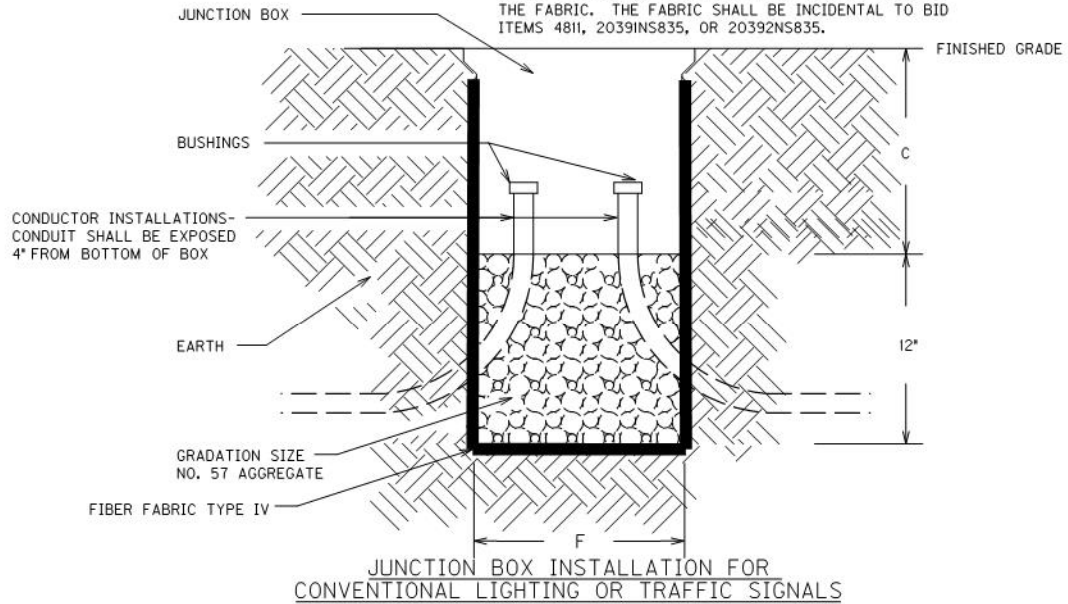

JUNCTION BOX INSTALLATION FOR
CONVENTIONAL LIGHTING OR TRAFFIC SIGNALS

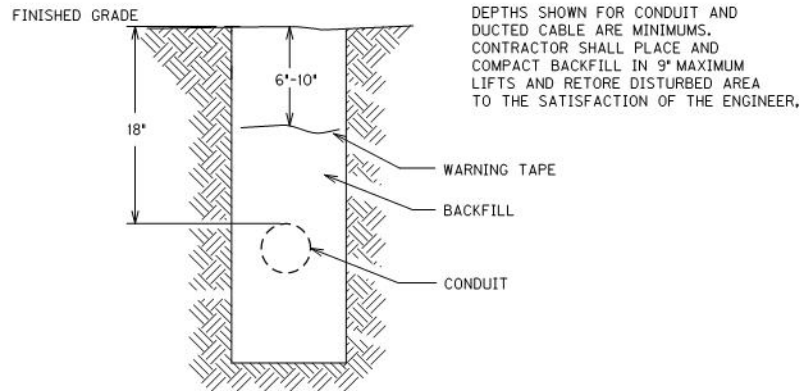

CONDUIT AND WARNING TAPE TRENCH

Traffic Signal Loop Detectors

Page 6 of 9

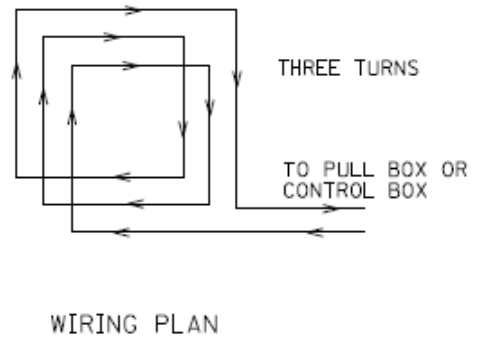
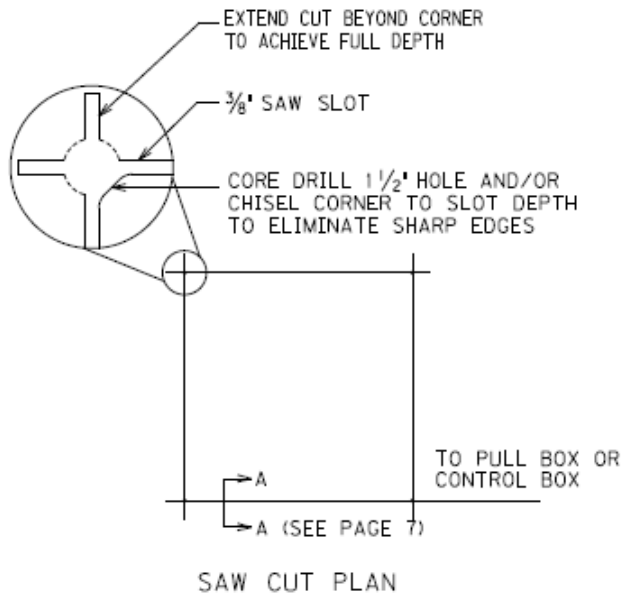

6'X6' LOOP

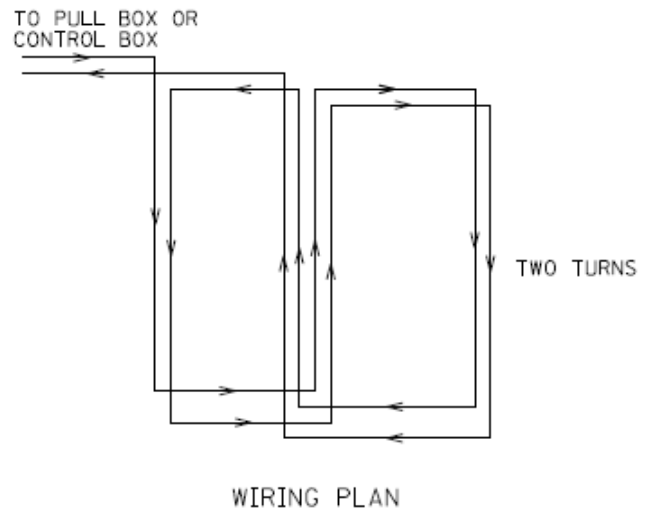
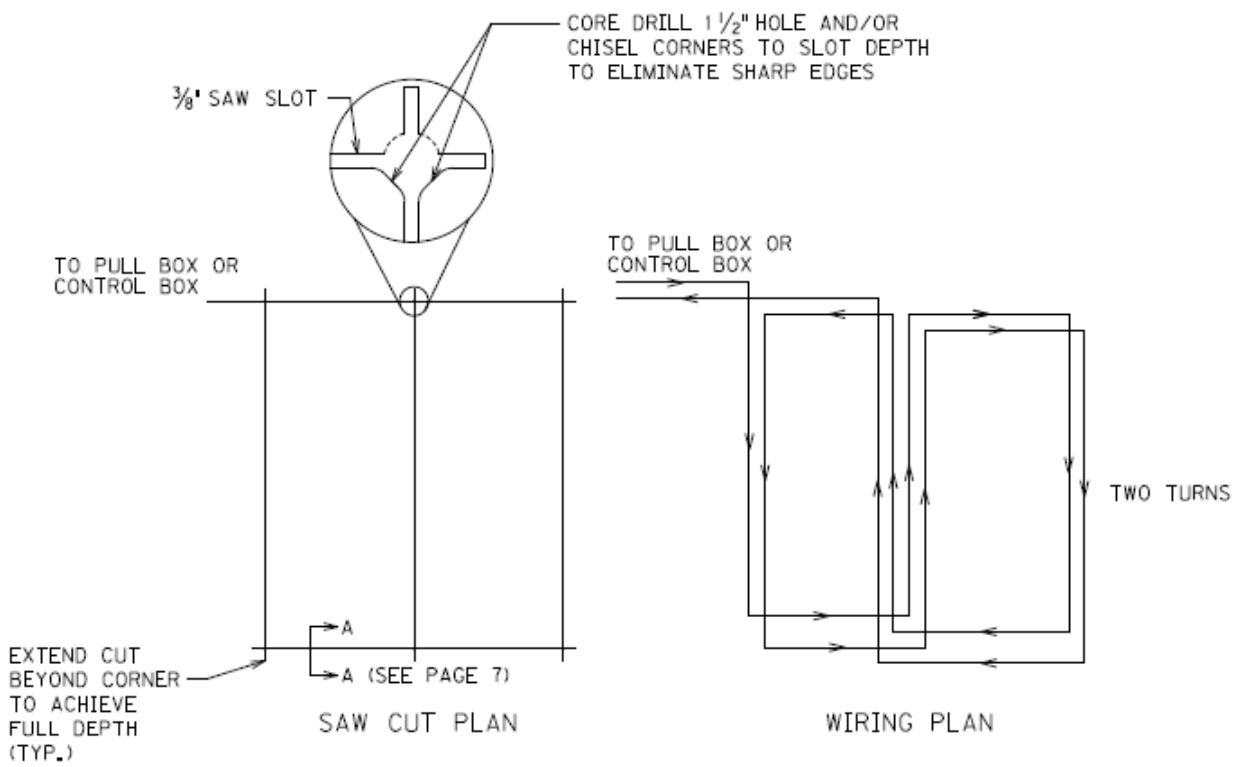

6'X30' QUADRAPOLE LOOP

Traffic Signal Loop Detectors
Page 7 of 9

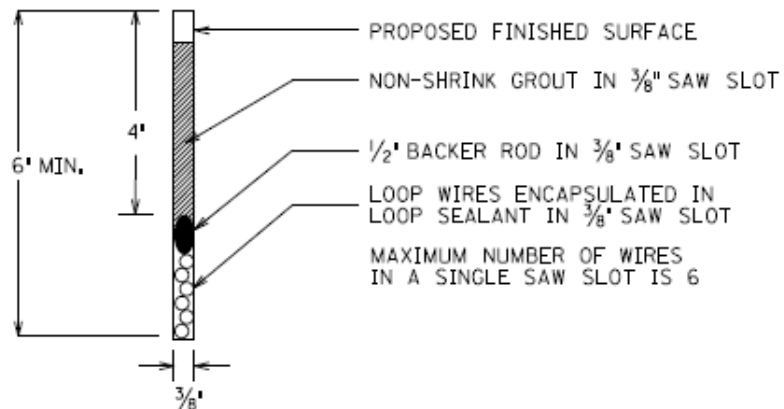

SECTION A-A (SAW SLOT DETAIL)

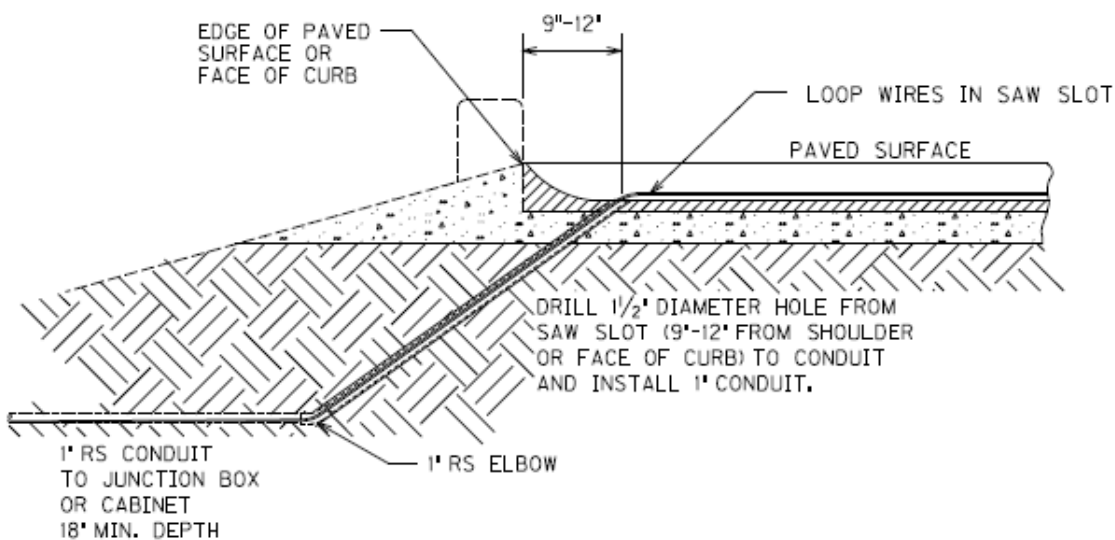

SAW SLOT EDGE OF PAVEMENT TRANSITION

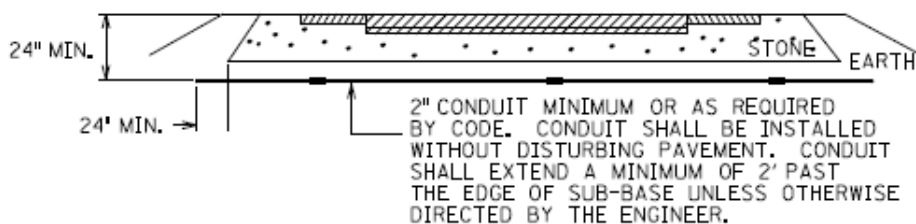

CONDUIT UNDER EXISTING PAVEMENT DETAIL

Traffic Signal Loop Detectors

Page 8 of 9

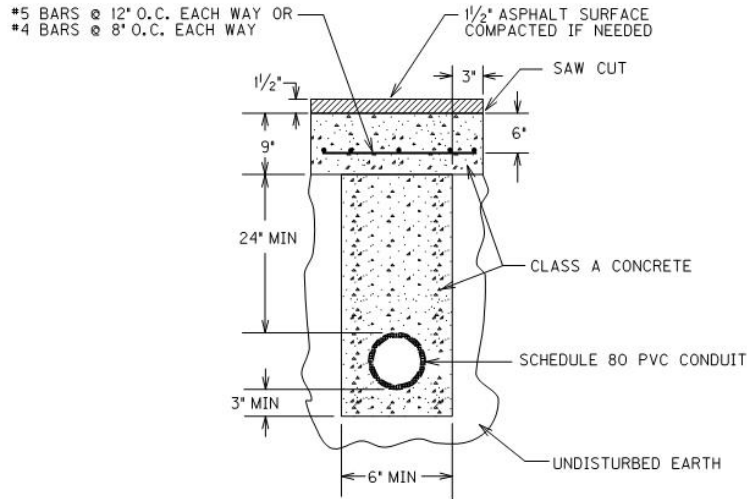

OPEN CUT PAVEMENT DETAIL

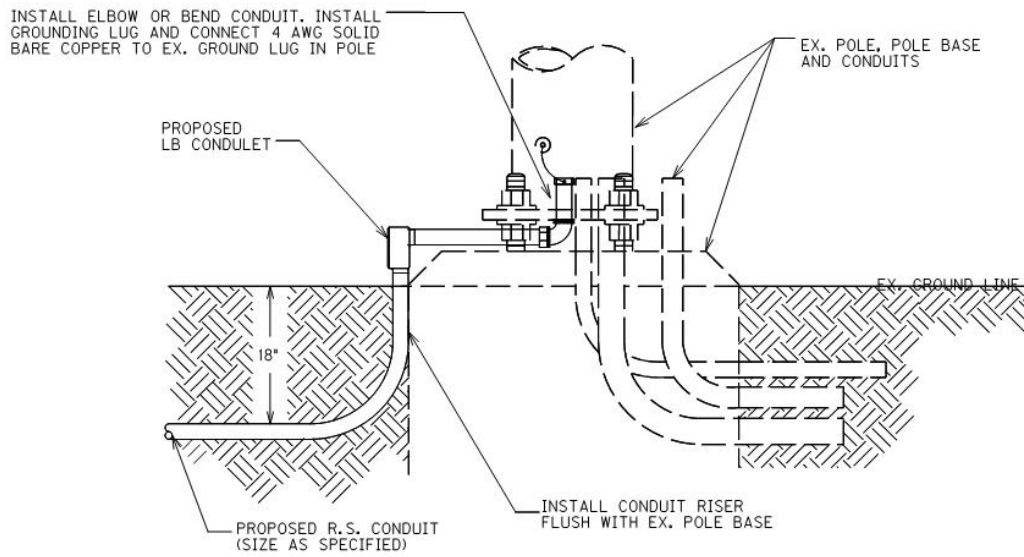

CONDUIT INSTALLATION IN EX. POLE BASE

Traffic Signal Loop Detectors

Page 9 of 9

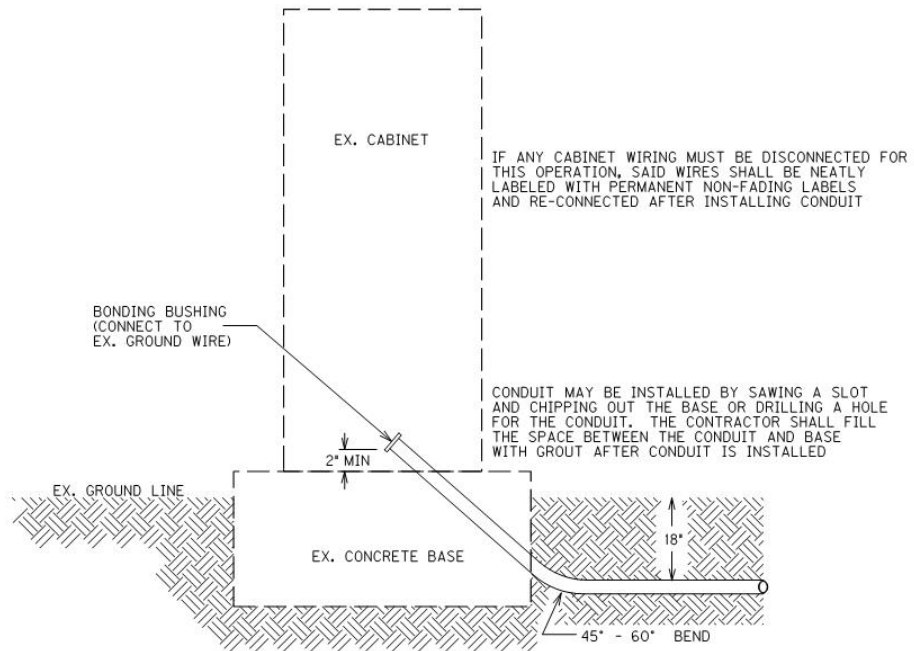

CONDUIT INSTALLATION IN EX. CABINET BASE

Update: 4-5-2022

	KENTUCKY TRANSPORTATION CABINET Department of Highways DIVISION OF RIGHT OF WAY & UTILITIES	TC 62-226 Rev. 01/2016 Page 1 of 1
RIGHT OF WAY CERTIFICATION		

<input checked="" type="checkbox"/>	Original	<input type="checkbox"/>	Re-Certification	RIGHT OF WAY CERTIFICATION
ITEM #	COUNTY	PROJECT # (STATE)	PROJECT # (FEDERAL)	
3-933.00	Warren	FD52 114 031W 001-002	HSIP 5081(006)	
PROJECT DESCRIPTION				

Installation of an Intersection Conflict Warning System and minor access management improvements at the intersection of US 31W & KY 240

No Additional Right of Way Required

Construction will be within the limits of the existing right of way. The right of way was acquired in accordance to FHWA regulations under the Uniform Relocation Assistance and Real Property Acquisitions Policy Act of 1970, as amended. No additional right of way or relocation assistance were required for this project.

Condition # 1 (Additional Right of Way Required and Cleared)

All necessary right of way, including control of access rights when applicable, have been acquired including legal and physical possession. Trial or appeal of cases may be pending in court but legal possession has been obtained. There may be some improvements remaining on the right-of-way, but all occupants have vacated the lands and improvements, and KYTC has physical possession and the rights to remove, salvage, or demolish all improvements and enter on all land. Just Compensation has been paid or deposited with the court. All relocations have been relocated to decent, safe, and sanitary housing or that KYTC has made available to displaced persons adequate replacement housing in accordance with the provisions of the current FHWA directive.

Condition # 2 (Additional Right of Way Required with Exception)



The right of way has not been fully acquired, the right to occupy and to use all rights-of-way required for the proper execution of the project has been acquired. Some parcels may be pending in court and on other parcels full legal possession has not been obtained, but right of entry has been obtained, the occupants of all lands and improvements have vacated, and KYTC has physical possession and right to remove, salvage, or demolish all improvements. Just Compensation has been paid or deposited with the court for most parcels. Just Compensation for all pending parcels will be paid or deposited with the court prior to AWARD of construction contract

Condition # 3 (Additional Right of Way Required with Exception)

The acquisition or right of occupancy and use of a few remaining parcels are not complete and/or some parcels still have occupants. All remaining occupants have had replacement housing made available to them in accordance with 49 CFR 24.204. KYTC is hereby requesting authorization to advertise this project for bids and to proceed with bid letting even though the necessary right of way will not be fully acquired, and/or some occupants will not be relocated, and/or the just compensation will not be paid or deposited with the court for some parcels until after bid letting. KYTC will fully meet all the requirements outlined in 23 CFR 635.309(c)(3) and 49 CFR 24.102(j) and will expedite completion of all acquisitions, relocations, and full payments after bid letting and prior to AWARD of the construction contract or force account construction.

Total Number of Parcels on Project	0	EXCEPTION (S) Parcel #	ANTICIPATED DATE OF POSSESSION WITH EXPLANATION
Number of Parcels That Have Been Acquired			
Signed Deed			
Condemnation			
Signed ROE			

Notes/ Comments (Use Additional Sheet if necessary)

LPA RW Project Manager		Right of Way Supervisor	
Printed Name		Printed Name	Mike Russell
Signature		Signature	
Date		Date	3/31/2022
Right of Way Director		FHWA	
Printed Name		Printed Name	
Signature		Signature	No Signature Required as per FHWA-KYTC Current Stewardship Agreement
Date	Digitally signed by Kelly R. Divine Date: 2022.03.31 12:13:40 -05'00'	Date	

UTILITIES AND RAIL CERTIFICATION NOTE

Warren County - HSIP 5081(006)
FD52 114 031W 001-002
Installation of an ICWS and minor access management improvements
at the intersection of US 31W (MPs 1.275 to 1.653) and KY 240
Item No. 3-933.00

GENERAL PROJECT NOTES ON UTILITIES

For all projects over 2000 linear feet, which are defined as a “Large Project” in KRS 367.4903(18), the awarded contractor shall initially mark the first 2000 linear feet minimally of proposed excavation or construction boundaries of the project to be worked using the procedure set forth in KRS 367.4909(9)(k). This temporary field locating of the project excavation boundary shall take place prior to submitting an excavation location request to the underground utility protection Kentucky Contact Center. For large projects, the awarded contractor shall work with the impacted utilities to determine when additional white lining of the remainder of the project site will take place. This provision shall not alter or relieve the awarded contractor from complying with requirements of KRS 367.4905 to 367.4917 in their entirety.

NOTE: The information presented in this Utility Note is informational in nature and the information contained herein is not guaranteed.

The contractor will be responsible for contacting all utility facility owners on the subject project to coordinate his/her activities. The contractor will coordinate his/her activities to minimize and, where possible, avoid conflicts with utility facilities. Due to the nature of the work proposed, it is unlikely to conflict with the existing utilities beyond minor facility adjustments. Where conflicts with utility facilities are unavoidable, the contractor will coordinate any necessary relocation work with the facility owner and Resident Engineer. The Kentucky Transportation Cabinet maintains the right to remove or alter portions of this contract if a utility conflict occurs. The utility facilities as noted in the previous section(s) have been determined using data garnered by varied means and with varying degrees of accuracy: from the facility owners, a result of S.U.E., field inspections, and/or reviews of record drawings. The facilities defined may not be inclusive of all utilities in the project scope and are not Level A quality, unless specified as such. It is the contractor’s responsibility to verify all utilities and their respective locations before excavating.

The contractor shall make every effort to protect underground facilities from damage as prescribed in the Underground Facility Damage Protection Act of 1994, Kentucky Revised Statute KRS 367.4901 to 367.4917. It is the contractor’s responsibility to determine and take steps necessary to be in compliance with federal and state damage prevention directives. The contractor is instructed to contact KY 811 for the location of existing underground utilities. Contact shall be made a minimum of two (2) and no more than ten (10) business days prior to excavation. The contractor shall submit Excavation Locate Requests to the Kentucky Contact Center (KY 811) via web ticket entry. The submission of this request does not relieve the contractor from the responsibility of contacting non-member facility owners, whom are to be contacted through their individual Protection Notification Center. It may be necessary for the contractor to contact the County Court Clerk to determine what utility companies have facilities in the area. Non-compliance with these directives can result in the enforcement of penalties.

UTILITIES AND RAIL CERTIFICATION NOTE

Warren County - HSIP 5081(006)
FD52 114 031W 001-002
Installation of an ICWS and minor access management improvements
at the intersection of US 31W (MPs 1.275 to 1.653) and KY 240
Item No. 3-933.00

NOTE: DO NOT DISTURB THE FOLLOWING UTILITIES LOCATED WITHIN THE PROJECT DISTURB LIMITS

There are no known utility relocations within the project limits. If an unknown utility is encountered, the contractor will be responsible for arranging an on-site meeting with the utility owner/representative(s) and the Engineer to discuss potential impacts and solutions to either avoid the utility or relocate the utility. Depending on the solution selected, the Engineer will determine whether or not additional contract time is appropriate.

- AT&T-KY – Telephone
- Charter Communications Holdings, LLC dba Spectrum - CATV
- LUMEN (CenturyLink Communications, LLC)
- Warren County Water District – Water
- Warren Rural Electric Cooperative Corporation - Electric

The Contractor is fully responsible for protection of all utilities listed above

THE FOLLOWING COMPANIES ARE RELOCATING/ADJUSTING THEIR UTILITIES WITHIN THE PROJECT LIMITS AND WILL BE COMPLETE PRIOR TO CONSTRUCTION

None

THE FOLLOWING COMPANIES HAVE FACILITIES TO BE RELOCATED/ADJUSTED BY THE COMPANY OR THE COMPANY’S SUBCONTRACTOR AND IS TO BE COORDINATED WITH THE ROAD CONTRACT

None

THE FOLLOWING COMPANIES HAVE FACILITIES TO BE RELOCATED/ADJUSTED BY THE ROAD CONTRACTOR AS INCLUDED IN THIS CONTRACT

None

RAIL COMPANIES HAVE FACILITIES IN CONJUNCTION WITH THIS PROJECT AS NOTED

- No Rail Involvement Rail Involved Rail Adjacent

UTILITIES AND RAIL CERTIFICATION NOTE

Warren County - HSIP 5081(006)
FD52 114 031W 001-002
Installation of an ICWS and minor access management improvements
at the intersection of US 31W (MPs 1.275 to 1.653) and KY 240
Item No. 3-933.00

AREA FACILITY OWNER CONTACT LIST

Facility Owner	Address	Contact Name	Phone	Email
AT&T-KY - Telephone	1150 State Street Bowling Green KY 42101	Travis Parsley	2708463196	tp2087@att.com
Charter Communications Holdings, LLC dba Spectrum - CATV	1900 North Fares Avenue Evansville IN 47711	Justin Sturgeon	8123058783	justin.sturgeon@charter.com
LUMEN (CenturyLink Communications, LLC)	700 West Mineral Avenue, UTD27.34 Littleton, Colorado 80120	Danett Kennedy, Right of Way Manager	17208886461	Relocations@lumen.com Danett.kennedy@lumen.com
Warren County Water District - Water	P.O. Box 10180 Bowling Green KY 42102	Ryan Leisey	2708420052	ryanl@warrenwater.com
Warren Rural Electric Cooperative Corporation - Electric	P.O. Box 1118 Bowling Green KY 42102	Jonathan Lindsey	2708426541	jonathanl@wrecc.com

NOTE: The Utilities Contact List is provided as informational only, and may not be a complete list of all Utility Companies with facilities in the project area.

COUNTY OF	ITEM NO.
WARREN	3-933.00

COMMONWEALTH OF KENTUCKY DEPARTMENT OF HIGHWAYS WARREN COUNTY

US 31W AT KY 240
3-933.00

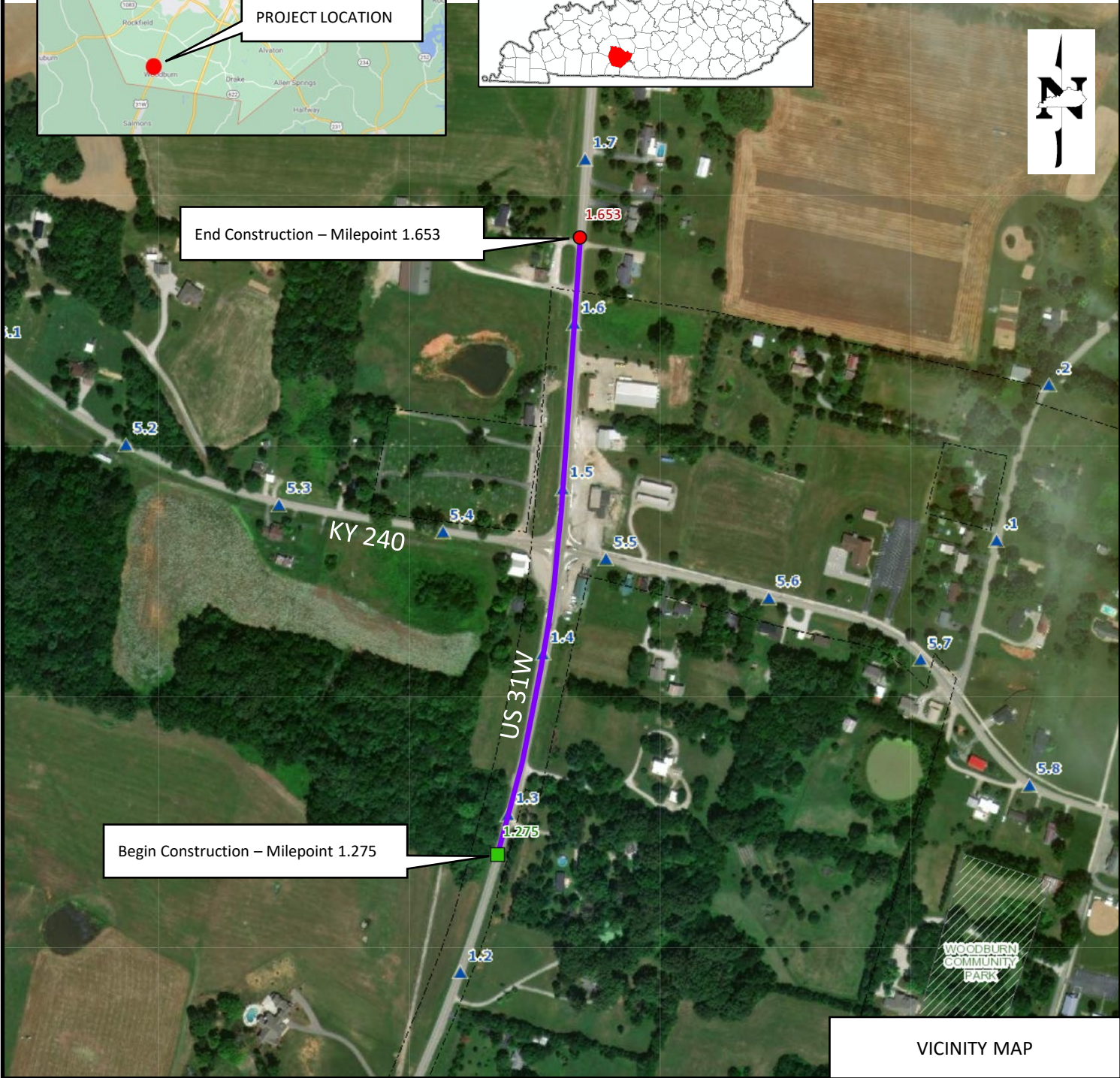
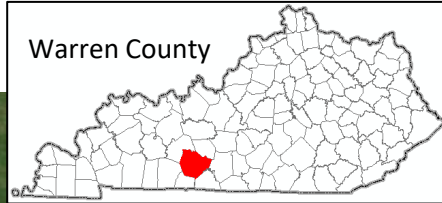
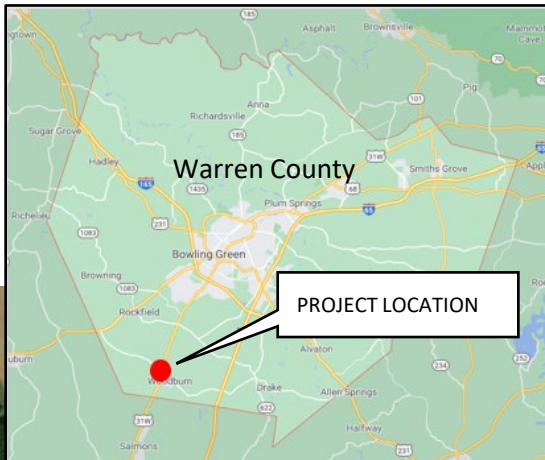

VICINITY MAP

**COMMONWEALTH OF KENTUCKY
DEPARTMENT OF HIGHWAYS**

COUNTY OF

ITEM NO.

WARREN

3-933.00

WARREN COUNTY - US 31W at KY 240

GENERAL SUMMARY

BID CODE	DESCRIPTION	UNITS	QTY
1	DGA BASE	TON	20.5
1917	STANDARD BARRIER MEDIAN TYPE 2	SQYD	48
2200	ROADWAY EXCAVATION	CUYD	15.5
2562	TEMPORARY SIGNS	SQFT	0
2650	MAINTAIN AND CONTROL TRAFFIC	LS	1
2671	PORTABLE CHANGEABLE MESSAGE SIGN	EACH	2
2703	SILT TRAP TYPE A	EACH	1
2704	SILT TRAP TYPE B	EACH	1
2705	SILT TRAP TYPE C	EACH	1
2706	CLEAN SILT TRAP TYPE A	EACH	1
2707	CLEAN SILT TRAP TYPE B	EACH	1
2708	CLEAN SILT TRAP TYPE C	EACH	1
2726	STAKING	LS	1
6546	PAVE STRIPING-THERMO-12 IN W	LF	404
6568	PAVE MARKING-THERMO STOP BAR-24 IN	LF	70
20430ED	SAW CUT	LF	85
22950NN	PAVE MARKING-THERMO STOP	EACH	2
24631EC	BARCODE SIGN INVENTORY	EACH	10
6410	STEEL POST TYPE 1	LF	130
6406	SBM ALUM SHEET SIGNS .080 IN	SQFT	6
6407	SBM ALUM SHEET SIGNS .125 IN	SQFT	140
4792	CONDUIT 1 INCH	LF	40
4795	CONDUIT 2 INCH	LF	450
4811	ELECTRICAL JUNCTION BOX TYPE B	EACH	10
4820	TRENCHING AND BACKFILLING	LF	850
4821	OPEN CUT ROADWAY	LF	450
4830	LOOP WIRE	LF	825
4845	CABLE-NO. 14/7C	LF	1,850
4850	CABLE-NO. 14/1 PAIR	LF	1,700
4885	MESSENGER-10800 LB	LF	175
4895	LOOP SAW SLOT AND FILL	LF	325
4932	INSTALL STEEL STRAIN POLE	EACH	2
20390NS835	INSTALL COORDINATING UNIT	EACH	1
20408ES835	INSTALL LED BEACON-12 IN	EACH	8
21543EN	BORE AND JACK CONDUIT	LF	450
23157EN	TRAFFIC SIGNAL POLE BASE	CUYD	7
24525EC	ADVANCE WARNING FLASHER	EACH	2
24900EC	PVC CONDUIT - 1 1/4 INCH - SCHEDULE 80	LF	810
24908EC	INSTALL SIGNAL CONTROLLER-TY ATC	EACH	1
24955ED	REMOVE SIGNAL EQUIPMENT	EACH	1
2569	DEMOBILIZATION	LS	1

GENERAL SUMMARY

COUNTY OF	ITEM NO.
WARREN	3-933.00

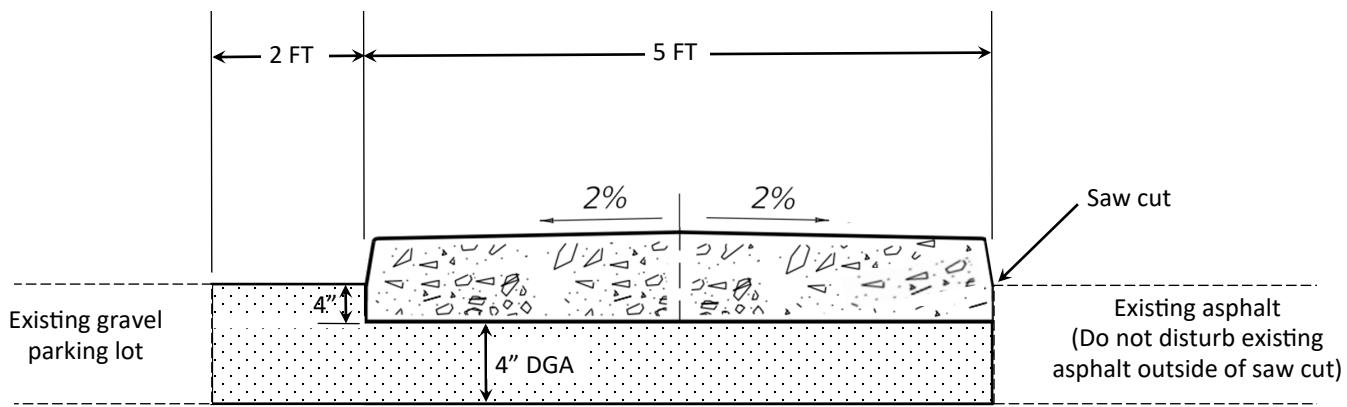

Section A—A

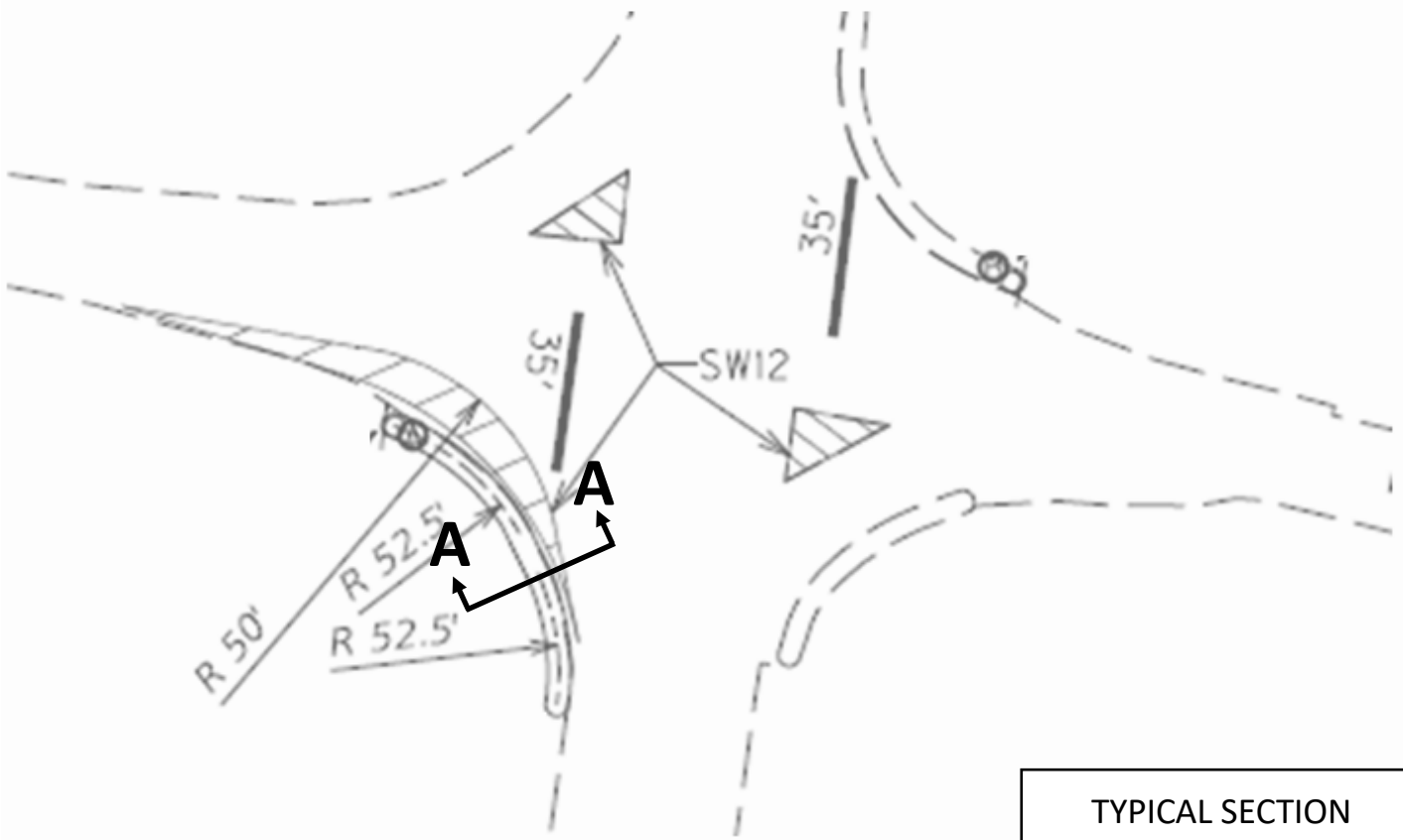

TYPICAL SECTION

LEGEND	
SW12	SOLID WHITE - STRIPING (12" THERMO) (6546) 404 LF
—	24" STOP BAR (6568) 70 LF

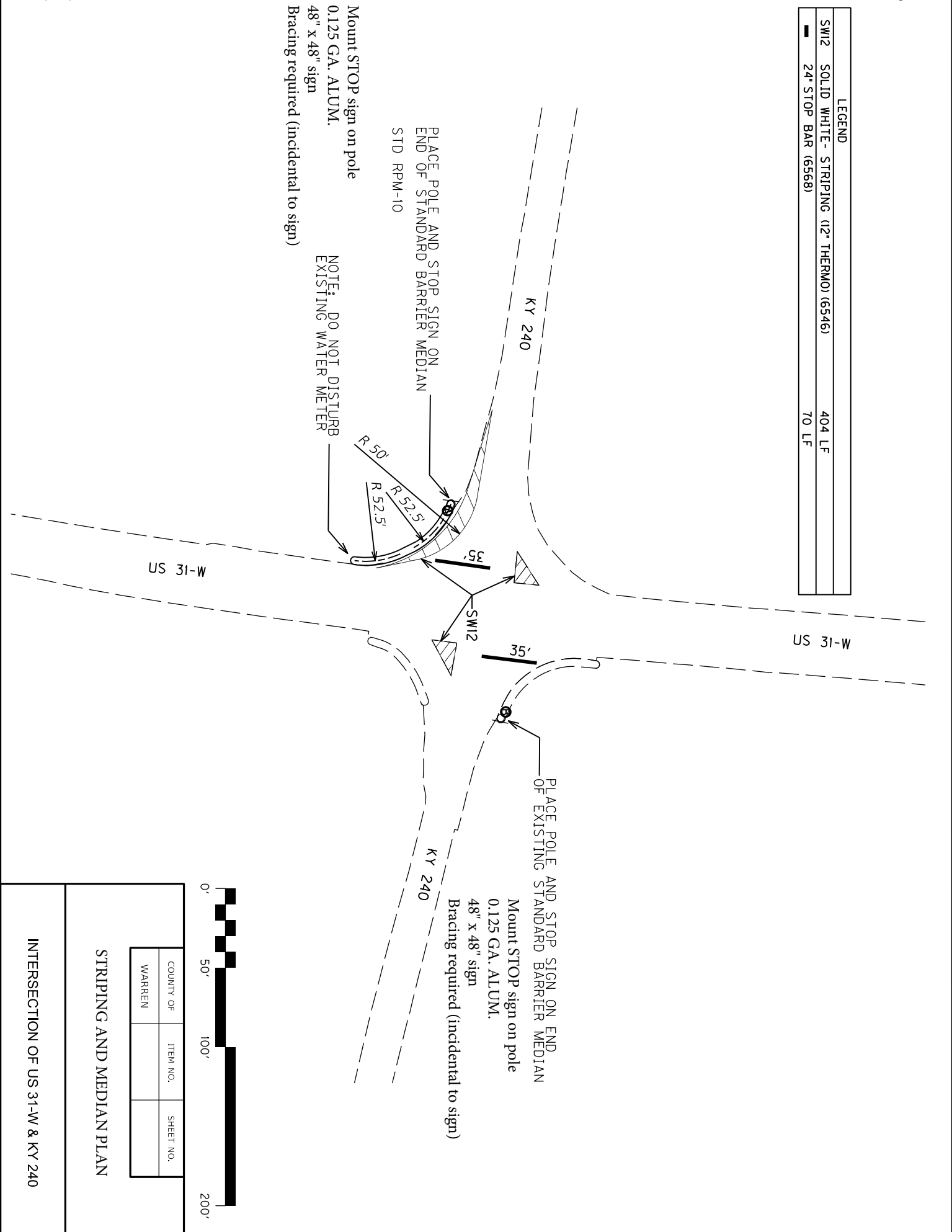

Mount STOP sign on pole
 0.125 GA. ALUM.
 48" x 48" sign
 Bracing required (incidental to sign)

NOTE: DO NOT DISTURB
 EXISTING WATER METER

PLACE POLE AND STOP SIGN ON
 END OF STANDARD BARRIER MEDIAN
 STD RPM-10

PLACE POLE AND STOP SIGN ON END
 OF EXISTING STANDARD BARRIER MEDIAN

Mount STOP sign on pole
 0.125 GA. ALUM.
 48" x 48" sign
 Bracing required (incidental to sign)



COUNTY OF	ITEM NO.	SHEET NO.
WARREN		

STRIPING AND MEDIAN PLAN

INTERSECTION OF US 31-W & KY 240

Power InRoads v8.11.9.397 E-SHEET NAME: T00200CA USER: Jessica.goodwin DATE PLOTTED: Apr 14, 2022 FILE NAME: G:\USERS\JESSICA.GOODWIN\DESKTOP\IC\W5\PLANS\T00200CA.DGN

5/4/2021

SEE POLE BASE DETAIL SHEET FOR GROUNDING DETAILS.

STEEL POLE MOUNT ENCLOSURE

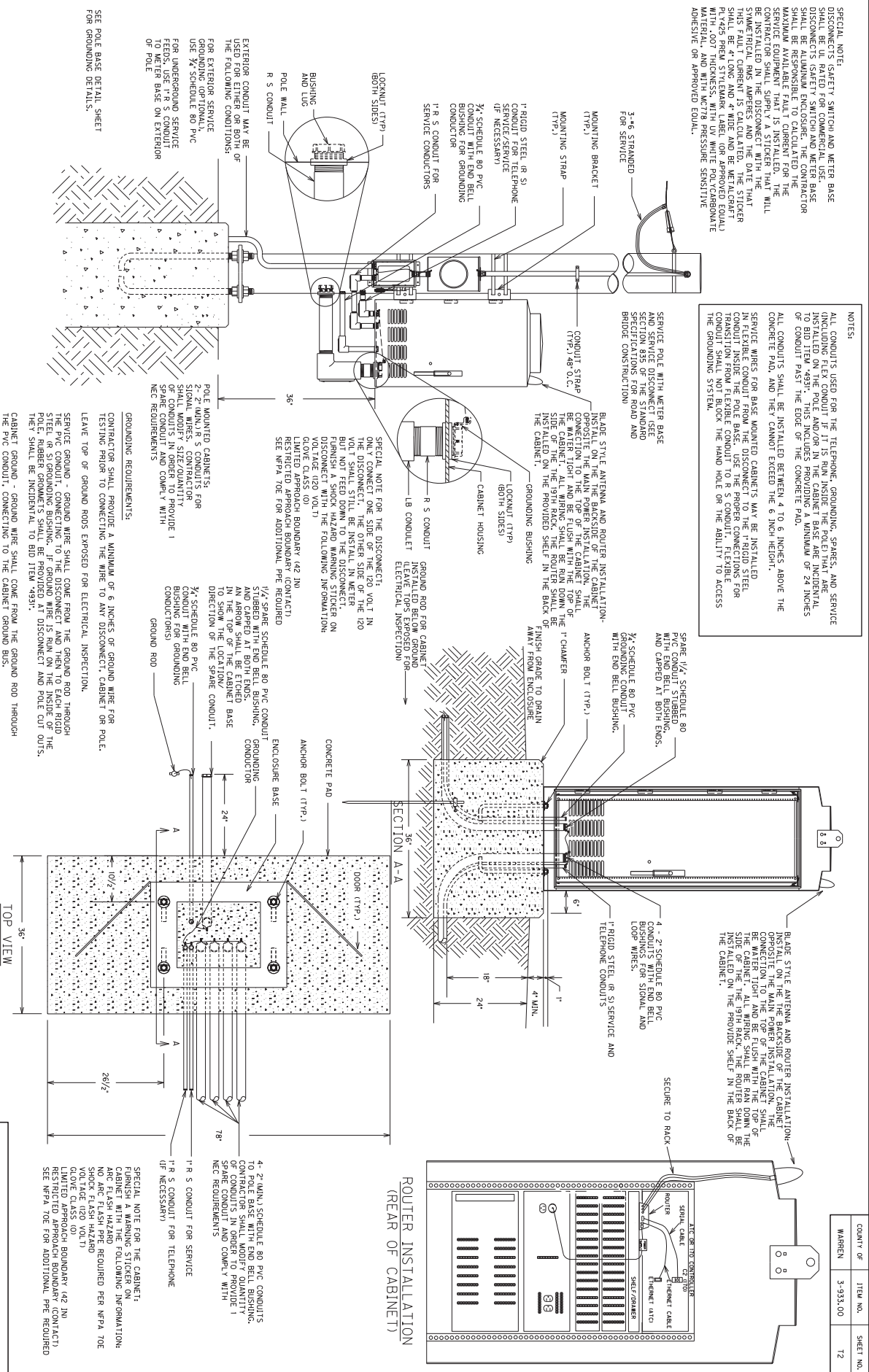

SPECIAL NOTE:
DISCONNECTS RATED FOR COMMERCIAL USE SHALL BE ALUMINUM ENCLOSURE. THE CONTRACTOR SHALL BE RESPONSIBLE TO CALCULATE THE SERVICE EQUIPMENT THAT IS INSTALLED. THE CONTRACTOR SHALL SUPPLY A STICKER THAT WILL BE INSTALLED IN THE DISCONNECT WITH THE DATE OF INSTALLATION AND THE DATE THE UNIT WAS INSTALLED. CURRENT IS TO BE CALCULATED SHALL BE 4" LONG AND 2" WIDE AND BE METAL GRAFT PLY 245 PREP STYLE MARK LABEL (OR APPROVED EQUAL) WITH .007" THICKNESS WITH UV WHITE POLYCARBONATE ADHESIVE OR APPROVED EQUAL.

NOTES:
ALL CONDUITS USED FOR THE TELEPHONE, GROUNDING, SPARES, AND SERVICE (INCLUDING FLEX CONDUIT IF IT IS RUN INSIDE THE POLE) THAT ARE INSTALLED ON THE POLE AND/OR IN THE CABINET BASE ARE INCIDENTAL OR BID ITEM 9591. THIS INCLUDES PROVIDING A MINIMUM OF 24 INCHES OF CONDUIT PAST THE EDGE OF THE CONCRETE PAD.
ALL CONDUITS SHALL BE INSTALLED BETWEEN 4 TO 6 INCHES ABOVE THE SERVICE WIRES FOR BASE MOUNTED CABINETS MAY BE INSTALLED IN FLEXIBLE CONDUIT FROM THE DISCONNECT TO THE 1" RIGID STEEL CONDUIT INSIDE THE POLE BASE. USE THE PROPER CONNECTIONS FOR CONDUIT SHALL NOT BLOCK THE HAND HOLE OR THE ABILITY TO ACCESS THE GROUNDING SYSTEM.

BLADE STYLE ANTENNA AND ROUTER INSTALLATION:
INSTALL ON THE BACKSIDE OF THE CABINET OPPOSITE THE MAIN POWER INSTALLATION. THE ANTENNA AND ROUTER SHALL BE RAN DOWN THE SIDE OF THE CABINET. ALL WIRING SHALL BE RAN DOWN THE SIDE OF THE CABINET. ALL WIRING SHALL BE INSTALLED ON THE PROVIDED SHELF IN THE BACK OF THE CABINET.

ROUTER INSTALLATION (REAR OF CABINET)

4- 2" MIN. SCHEDULE 80 PVC CONDUITS TO POLE BASE WITH END BELL BUSHING. CONTRACTOR SHALL MODIFY QUANTITY OF CONDUITS IN ORDER TO PROVIDE 1 N.E.C. REQUIREMENTS WITH N.E.C. REQUIREMENTS.

1" R 5 CONDUIT FOR SERVICE (IF NECESSARY)

1" R 5 CONDUIT FOR TELEPHONE (IF NECESSARY)

SPECIAL NOTE FOR THE CABINET:
FURNISH A WARNING STICKER ON THE FRONT OF THE CABINET. THE STICKER SHALL BE 4" X 6" IN SIZE. NO ARC FLASH HAZARD INFORMATION IS REQUIRED PER NFPA 70E LIMITED APPROACH BOUNDARY (42 IN) RESTRICTED APPROACH BOUNDARY (CONTACT) SEE NFPA 70E FOR ADDITIONAL PRE REQUIRED

GROUNDING REQUIREMENTS:
CONTRACTOR SHALL PROVIDE A MINIMUM OF 6 INCHES OF GROUND WIRE FOR TESTING PRIOR TO CONNECTING THE WIRE TO ANY DISCONNECT, CABINET OR POLE. LEAVE TOP OF GROUND ROSS EXPOSED FOR ELECTRICAL INSPECTION.
SERVICE GROUND - GROUND WIRE SHALL COME FROM THE GROUND ROD THROUGH THE PVC CONDUIT, CONNECTING TO THE DISCONNECT AND THEN TO EACH RIGID POLE. RUBBER GROUNDING SHALL BE PROVIDED AT DISCONNECT AND POLE CUT OUTS. THEY SHALL BE INCIDENTAL TO BID ITEM 4931V.
CABINET GROUND - GROUND WIRE SHALL COME FROM THE GROUND ROD THROUGH THE PVC CONDUIT, CONNECTING TO THE CABINET GROUND BUS.

PAD MOUNT ENCLOSURE

CONTROLLER CABINET AND ANTENNA/ROUTER DETAIL

STEEL POLE MOUNT ENCLOSURE

Power InRoads v8.11.9.397 E-SHEET NAME: T0030LP USER: Jessica.goodwin DATE PLOTTED: Apr 14, 2022 FILE NAME: G:\USERS\JESSICA.GOODWIN\DESKTOP\ICWS\PLANS\T0030LP.DGN

COUNTY OF	ITEM NO.	SHEET NO.
WARREN	3-933.00	13

SECTION B-B (TWIST NOTE)
-FOR CANCELING OUT CROSSTALK

3 TO 5 TURNS PER FOOT FROM THE START OF THE HOVERRUN TO THE JUNCTION BOX, CABINET, OR POLE. THE TEE SHALL BE CONSTRUCTED OF HEAVY DUTY HIGH TEMPERATURE SYNTHETIC RUBBER, STANDARD WIRE SHALL BE WELDED TO THE HOVERRUN TO HELP WITH THE INSTALLATION OF THE TWISTED WIRE.

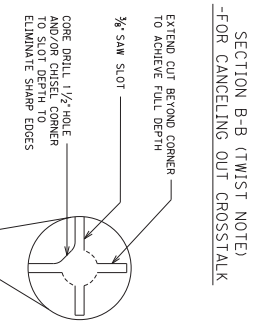

SECTION A-A (SAW SLOT DETAIL)

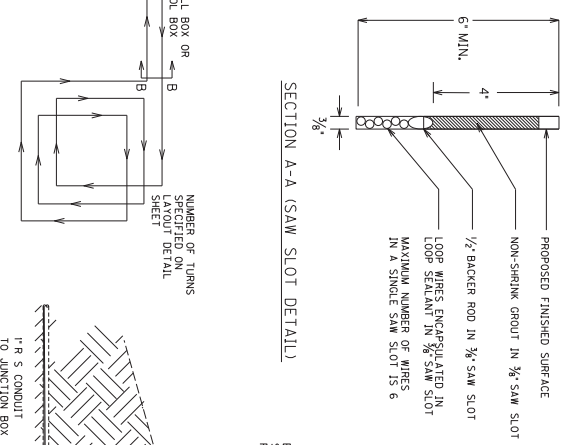

ASPHALT SAW SLOT DETAIL FOR PREFORMED

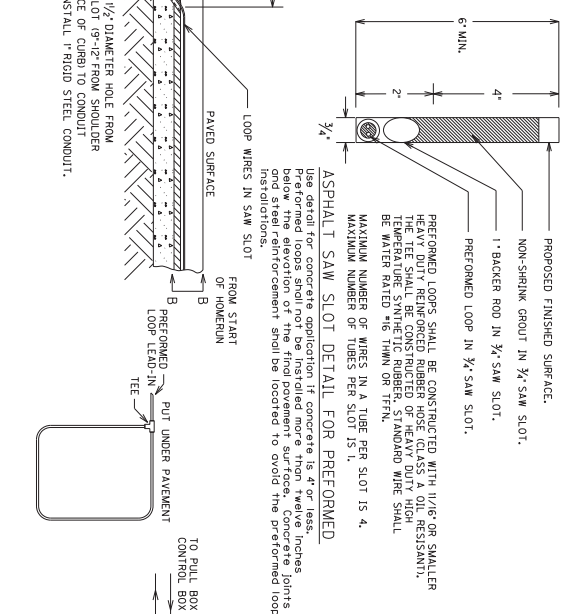

SAW CUT PLAN

6'X6' LOOP

LOOP WIRE PLAN

SAW SLOT EDGE OF PAVEMENT TRANSITION

PREFORMED LOOP DIAGRAM

6'X6' PREFORMED LOOP

LOOP WIRE PLAN

CONSTRUCTION DETAILS FOR LOOP SAW SLOT AND FILL BID ITEM THE FOLLOWING IS A TYPICAL STEP BY STEP PROCEDURE FOR THE INSTALLATION OF A LOOP:

- CAREFULLY MARK THE SLOT TO BE CUT, PERPENDICULAR TO THE FLOW OF TRAFFIC.
- MAKE EACH SAW CUT 3/8" WIDE AND AT A DEPTH SUCH THAT THE TOP OF THE BACKER ROD IS A MINIMUM OF 4 INCHES BELOW THE SURFACE OF ASPHALT PAVEMENT.
- REMOVE 1/2" INCH CORE HOLE AT EACH CORNER AND USE A CHISEL TO SMOOTH THE CORNERS TO PREVENT SHARP BENDS IN THE WIRE.
- CLEAN ALL FOREIGN AND LOOSE MATTER OUT OF THE SLOTS, DRILLED CORES, COMPLETELY OVER THE SLOTS, DRILLED CORES, AND WITHIN 1 FOOT ON ALL SIDES OF THE SLOTS.
- MEASURE 9-12 INCHES FROM THE EDGE OF THE PAVED SURFACE (SHOULDER BREAK CONDUIT ADJACENT TO THE ROADWAY).
- CLOSELY INSPECT ALL CUTS, CORES, AND SLOTS FOR JAGGED EDGES OR PROTRUSIONS. SHALL BE GRIND OR BE CUT AND CLEANED AGAIN.
- INSTALL 1" RIGID STEEL CONDUIT IN 45 DEGREE DRILLED SLOT. CONNECT CONDUIT TO 1" RIGID STEEL CONDUIT ADJACENT TO THE ROADWAY WITH RIGID STEEL ELBOW.
- NOTE: THE LOOP WIRE SHALL BE FREE FROM THE TERMINATION POINT. SEE SECTION B-B.
- PUSH THE WIRE INTO THE SAW SLOT WITH A BLUNT OBJECT SUCH AS A WOODEN SAW SLOT SCREWDRIVER. SHALL NOT BE USED.
- INSTALL DUCT SEALANT TO A MINIMUM OF 1 INCH DEEP INTO THE CORED 1 1/2" INCH HOLE.
- LOOP SEALANT FROM THE BOTTOM UP AND FULLY ENCAPSULATE THE LOOP WIRE IN THE SAW SLOT. THE WIRE SHOULD NOT BE ABLE TO MOVE WHEN THE SEALANT HAS SET.
- COVER THE ENCAPSULATED LOOP WIRE WITH A CONTINUOUS LAYER OF BACKER GROUT. THE ENCAPSULATION AND FROM SAW SLOTS SHALL BE AT LEAST 100DS ARE PRESENT BETWEEN THE LOOP SEALANT AND BACKER ROD.
- FINISH FILLING THE SAW CUT WITH NON-SHRINKABLE GROUT PER MANUFACTURER'S INSTRUCTIONS. SHALL BE CLEANED FROM THE ROADWAY TO ALEEVATE TRACKING.
- ANY EXCESS GROUT SHALL BE CLEANED FROM THE ROADWAY TO ALEEVATE TRACKING.
- REMOVE ALL WASTE FROM THE PROJECT AREA IMMEDIATELY AFTER COMPLETING THE LOOP TO TRAFFIC. CURING TIME VARIES WITH TEMPERATURE AND HUMIDITY.

PREFORMED LOOP LEAD-IN SHALL BE TWISTED WITH THREE TO FIVE TURNS PER FOOT UNTIL TERMINATED AT FIELD CONDUIT OR CABINET OR CONNECTED TO SHIELDED CABLE.

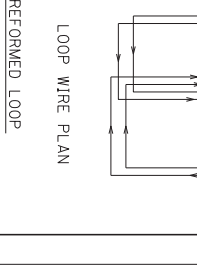
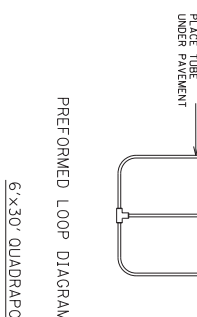
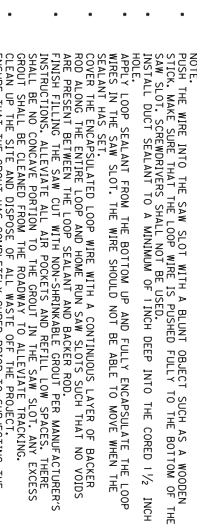
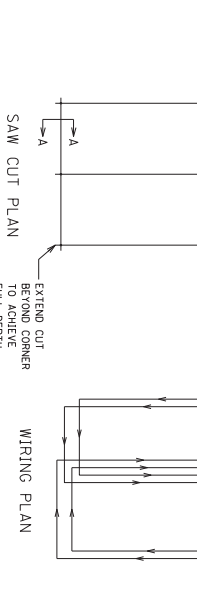
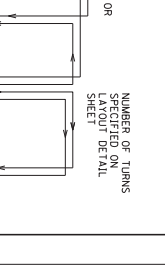
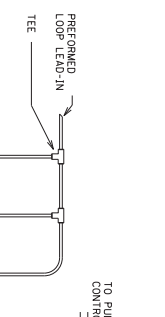
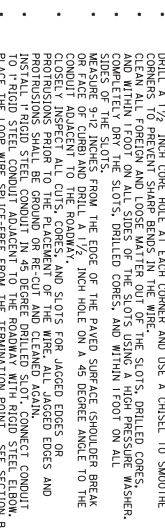
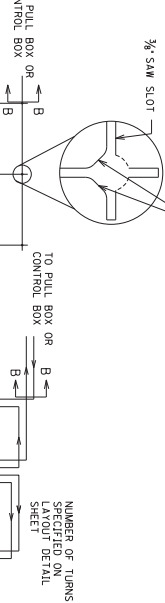

10/25/2021 6'X30' QUADRANGLE LOOP LOOP DETAILS

Power InRoads v8.11.9.397 E-SHEET NAME: T00400PO USER: Jessica.goodwin DATE PLOTTED: April 14, 2022 FILE NAME: G:\USERS\JESSICA.GOODWIN\DESKTOP\ICWS\PLANS\T00400PO.DGN

NOTES:
ALL CONDUITS USED FOR THE TELEPHONE, GROUNDING, SPARE, AND SERVICE THAT ARE INSTALLED IN THE POLE BASE ARE INCIDENTAL TO BID ITEM "23197EN". THIS INCLUDES PROVIDING A MINIMUM OF 24 INCHES OF CONDUIT PAST THE EDGE OF THE CONCRETE POLE BASE.
ALL CONDUITS SHALL BE INSTALLED BETWEEN 4 TO 6 INCHES ABOVE THE CONCRETE PAD, AND THEY CANNOT EXCEED THE 6 INCH HEIGHT.
FOR POLE BASE DEPTH, SEE CHART IN SECTION 723 OF THE Kentucky STANDARD SPECIFICATIONS FOR ROAD AND BRIDGE CONSTRUCTION, CURRENT EDITION.
OVERHEAD SERVICE WIRES SHALL BE INSTALLED ON THE EXTERIOR OF THE POLE IN A 1" RIGID STEEL CONDUIT WITH WEATHERHEAD, OR ON THE INSIDE THE STEEL STRAIN POLE IN FLEXIBLE CONDUIT.
UNDERGROUND SERVICE WIRES SHALL BE INSTALLED IN 1" RIGID STEEL CONDUIT AS SHOWN ON THE CONTROLLER CABINET DETAIL SHEET.
PROVIDE 2 FOOT COIL IN SIGNAL CABLES TO PREVENT WATER ACCESS TO WEATHERHEADS FOR EACH SIGNAL HEAD.
5% MIN. SAG FOR ALL SPANS OR OTHERWISE NOTED

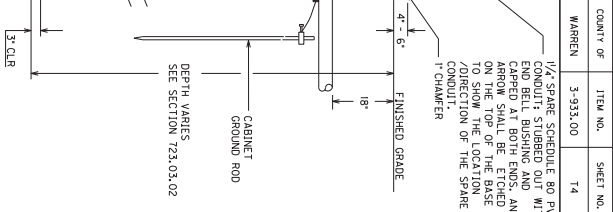
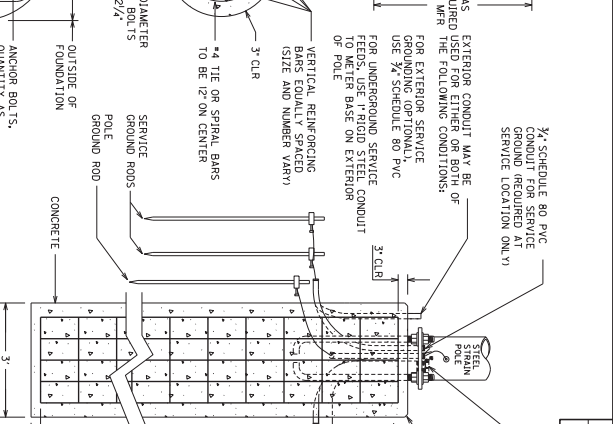
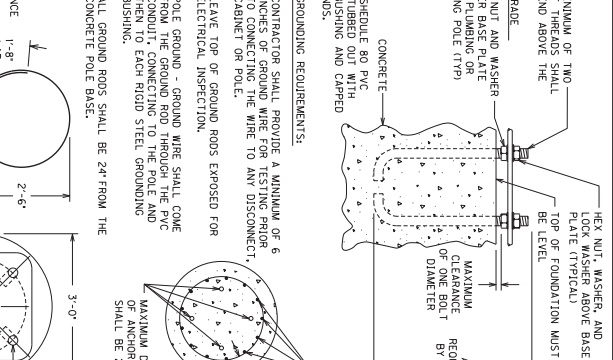
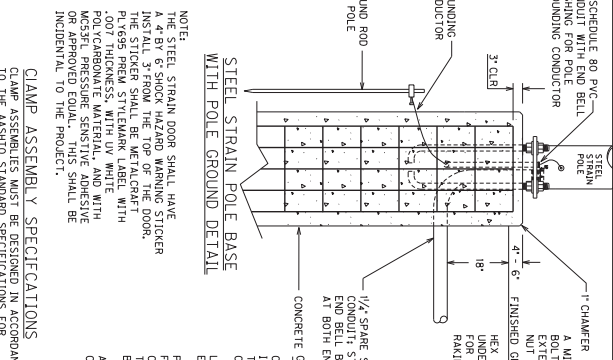
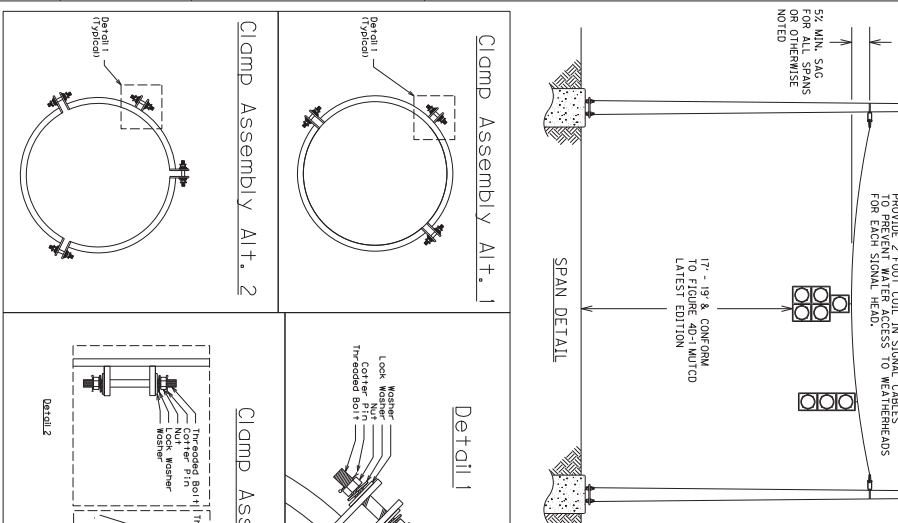

4/15/2021

CLAMP ASSEMBLY SPECIFICATIONS:
CLAMP ASSEMBLIES MUST BE DESIGNED IN ACCORDANCE WITH THE FOLLOWING: A. 4 BY 6 SHOCK HAZARD WARNING STICKER THE STICKER SHALL BE METAL, GRAF DOK, PLY699 PREEM STYLE, MARK LABEL WITH .007 THICKNESS, WITH UV WHITE WITH MOSER PRESSURE SENSITIVE ADHESIVE OR APPROVED EQUAL. THIS SHALL BE INCIDENTAL TO THE PROJECT.
NOTE: THE STEEL STRAIN DOOR SHALL HAVE A 4 BY 6 SHOCK HAZARD WARNING STICKER THE STICKER SHALL BE METAL, GRAF DOK, PLY699 PREEM STYLE, MARK LABEL WITH .007 THICKNESS, WITH UV WHITE WITH MOSER PRESSURE SENSITIVE ADHESIVE OR APPROVED EQUAL. THIS SHALL BE INCIDENTAL TO THE PROJECT.

CLAMP ASSEMBLY A1+1:
Detail 1

CLAMP ASSEMBLY A1+2:
Detail 1

CLAMP ASSEMBLY A1+3:
Detail 1

CLAMP/CLAVIS: ASTM A36 GRADE 36/ASTM A572 GRADE 50
BOLTS (EXCEPT U-BOLTS) - HIGH STRENGTH ASTM A325, ASTM A449, OR ASTM A490
U-BOLTS - MINIMUM ASTM A36 GALVANIZING - ASTM A153

BENDING DETAIL FOR THE BARS:
CARVED LOCATION FOR THE BARS
IF ANCHOR BOLTS ARE STRAIGHT NOT BEND, THE METAL TEMPLATE SHALL BE INSTALLED FOR STRUCTURAL INTEGRITY.

SPAN WIRE DETAIL:
PROVIDE SAG IN WIRES TO PREVENT WATER IN WEATHERHEAD

AERIAL CORNER DETAIL:
JOHNWAYBOLTS OR STRAIN ISOLATORS SHALL NOT BE USED ON THE ATTACHMENT OF THE SPAN WIRE TO THE POLE.
INSTALL MESSENGER THROUGH STRAND VISE AND BEND MESSENGER AT EXIT POINT.
MESSENGER SHALL EXTEND 8" TO 10" BEYOND THE STRAND VISE TAIL.
THERE SHALL BE A SEPARATE COLLAR USED FOR EACH SPAN.

BACKPLATE DETAIL:
FOR EQUIPMENT GROUND SIGNAL/RED HEADS: CONNECT GREEN WIRE FROM SERVICE JANSK CABLE UNDER ONE OF THE BOLTS FOR THE STRUD ASSEMBLY THAT CONNECTS THE HEADS. WE RECOMMEND BUTTED SEAM CLOSED BARREL FOR THIS CONNECTION.

COUNTY OF	ITEM NO.	SHEET NO.
WARREN	3-933.00	14

1/2" SPARE SCHEDULE 80 PVC CONDUIT STUBBED OUT WITH END BELL BUSHING AND AN ARROW SHALL BE ETCHED ON THE TOP OF THE BASE TO SHOW THE LOCATION OF THE SPARE CONDUIT.
FINISHED GRADE
GROUND ROD
CABINET
DEPTH VARIES SEE SECTION 723.03.02

Power InRoads v8.11.9.397 E-SHEET NAME: T00600SP USER: Jessica.goodwin DATE PLOTTED: Apr 14, 2022 FILE NAME: G:\USERS\JESSICA.GOODWIN\DESKTOP\ICWS\PLANS\T00600SP.DGN

3/10/2017

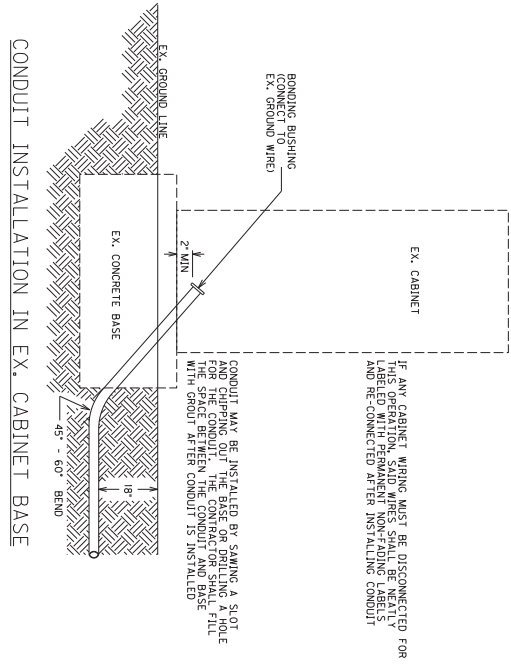

OPEN CUT PAVEMENT DETAIL

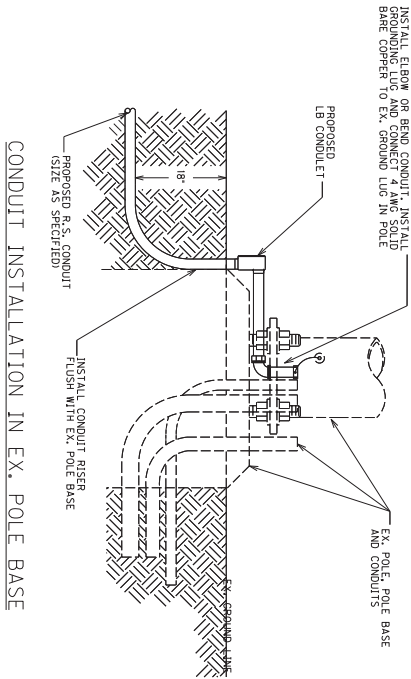
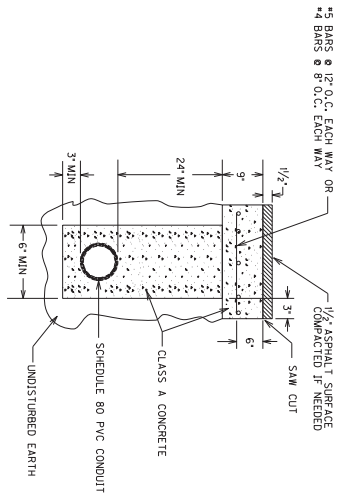

CONDUIT INSTALLATIONS IN
EXISTING LOCATIONS

COUNTY OF	ITEM NO.	SHEET NO.
WARREN	3-933.00	T6

**PROJECT MATERIALS RELEASE FORM
 FOR SIGNAL AND LIGHTING**

Note: Email form with signatures to KYTC's warehouse (kim.stamper@ky.gov) at least two (2) days prior to arrival for pickup. Ensure Contractor's delivery driver has a copy of form with signatures. Failure to do either may result in long delays or refusal to distribute materials upon arrival.

Item Number: 3-933.00
 County: Warren
 Description: ICWS for US 31W @ KY 240

Cabinets		Master code
1	T-01-0020	Base Mounted 332 Cabinet
1	T-01-0030	Battery Backup System (Piggyback)
1	T-01-0105	ATC Controller
1	T-01-0106	1C w/Maxtime (this should go with item ATC controller)
1	T-01-0510	Isolator, Model 242 (1 for 2070, plus for ped detector and railroad)
4	T-01-0600	Loop Detector, Model 222
4	T-01-0700	Load Switches

Signals	
8	T-02-0080 12 inch red/yellow beacon
8	T-02-0340 LED Module 12" yellow ball

Special items	
1	T-02-0504 Router (this includes power supply/antenna/cabling)
4	T-09-0410 Sign Hanger for 48" signs

Poles	
2	T-04-0020 Steel Strain Pole 30 foot

REQUIRED

Electrical Contractor Name _____
 Electrical Contractor Supervisor _____ Contact number for Supervisor _____
 Project Engineer _____ Contact number for Project Engineer _____
 Project Engineer attests that the mentioned contractor is the actual electrical contractor on this project
 Signature of Project Engineer or Designee _____

COUNTY OF	ITEM NO.	SHEET NO.

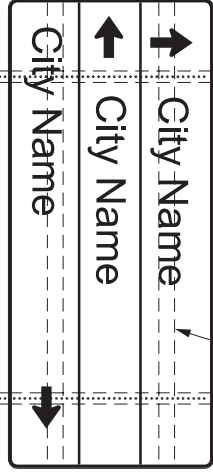

SEE SHEETING SIGN DETAIL SHEET 2 OF 2 FOR BRACING REQUIREMENTS

NOTE: SEE SIGN DETAIL SHEETS FOR QUANTITY, LENGTH, SIZE AND GAUGE OF TYPE I POSTS

PLAN VIEW
NOT TO SCALE

PLAN VIEW
NOT TO SCALE

PLAN VIEW
NOT TO SCALE

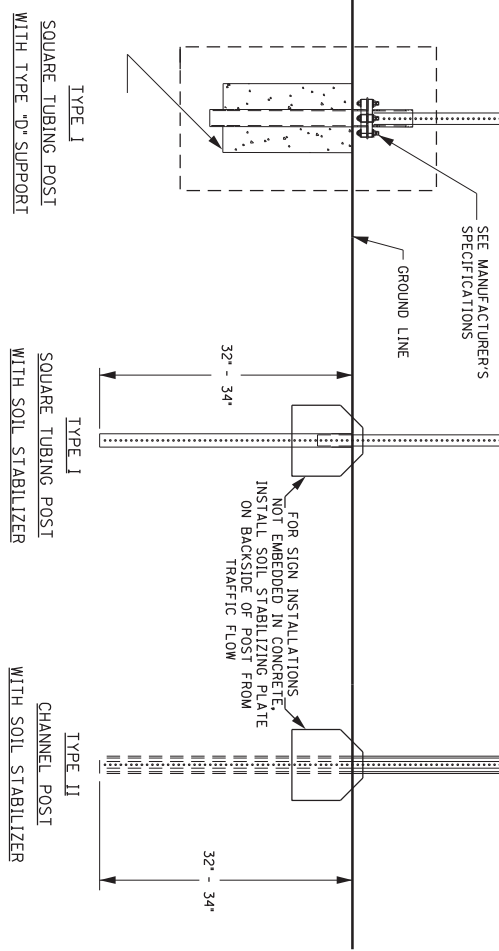

SEE MANUFACTURER'S SPECIFICATIONS

FOR SIGN INSTALLATIONS NOT EMBEDDED IN CONCRETE, INSTALL SOIL STABILIZING PLATE ON BACKSIDE OF POST FROM TRAFFIC FLOW

ADDED HOLE IN SOIL PLATE
STRAIGHT 3/8"-16 x 3"
GRADE 5 HEX CAP SCREW,
NUT, & TWO WASHERS

HOLES ARE 1" ON CENTER

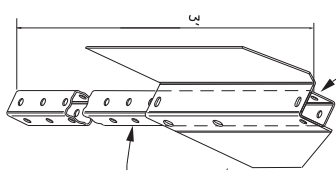

SOIL STABILIZER DETAIL

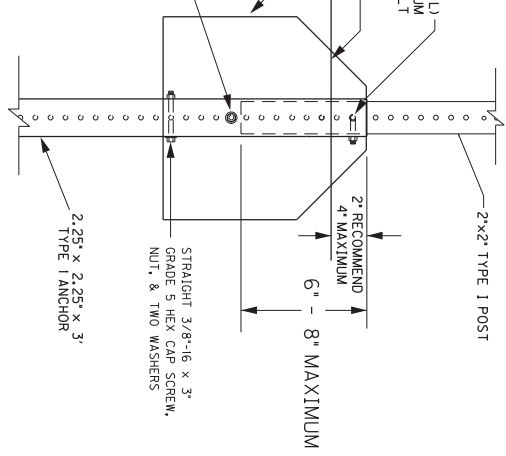

SOIL STABILIZER DETAIL
FOR TYPE I POST

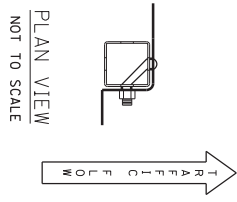

PLAN VIEW
NOT TO SCALE

NOT TO SCALE

SHEETING SIGN DETAIL
SHEET 1 OF 2

FOR ATTACHMENT OF SIGNS
LESS THAN 72" IN WIDTH
USING MANUFACTURED 3/8" HOLES
ACCORDING TO 2004 STANDARD
HIGHWAY SIGNS BLANK
STANDARDS
POST 7-1 THRU 7-6

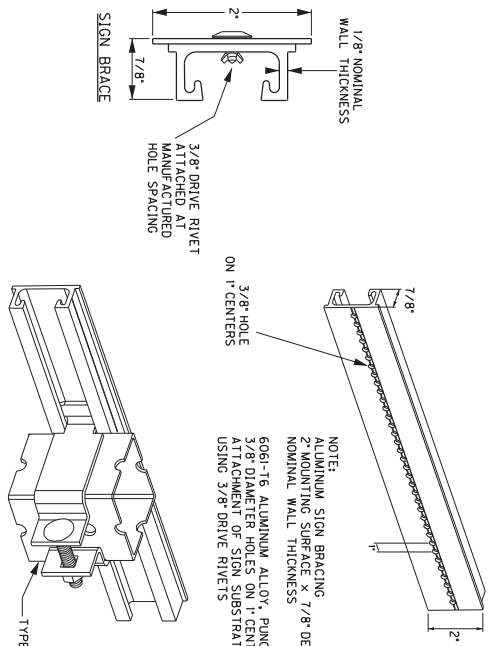

SQUARE POST CLAMP & BRACE

TYPE I SQUARE POST

FOR ATTACHMENT OF SIGNS
GREATER THAN, OR EQUAL TO,
72" IN WIDTH,
RIVETS SHALL BE COLOR CODED
TO MATCH SHEETING IN ORDER
TO MINIMIZE GLARE FROM RIVETS

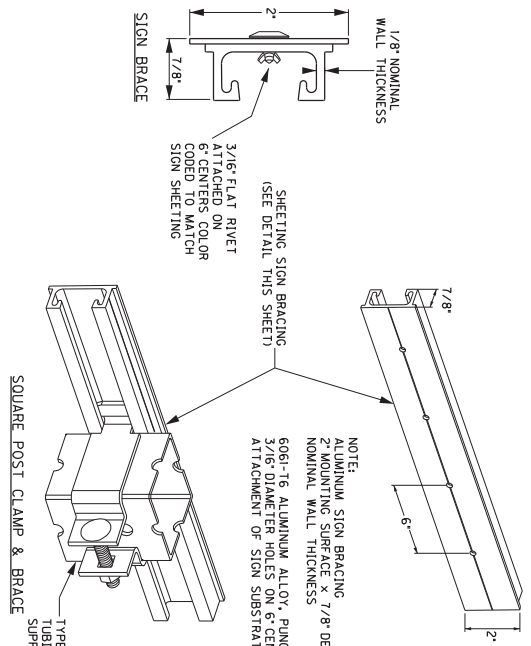

SQUARE POST CLAMP & BRACE

TYPE I SQUARE TUBING SIGN SUPPORT

NOTE:
ALUMINUM SIGN BRACING
2" MOUNTING SURFACE x 7/8" DEPTH x 1/8"
NOMINAL WALL THICKNESS
6061-T6 ALUMINUM ALLOY, PUNCHED WITH
3/16" DIAMETER HOLES ON 6" CENTERS FOR
ATTACHMENT OF SIGN SUBSTRATE USING RIVETS

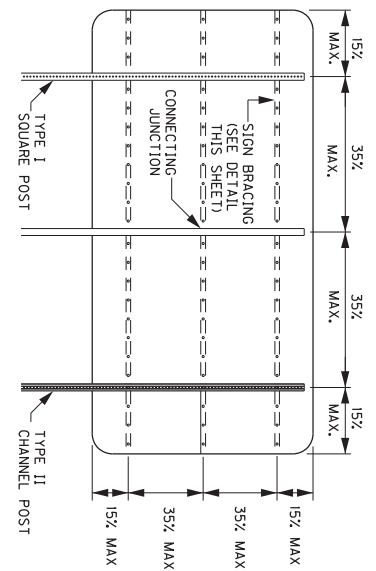

2 POST - BRACING DIAGRAM

NOTE:
1. MAXIMUM AREA PER CONNECTING JUNCTION = 16 SQ. FT.
2. BRACING SHOULD NOT BE SPICED WITHIN 6" OF A BRACE TO POST JUNCTION.

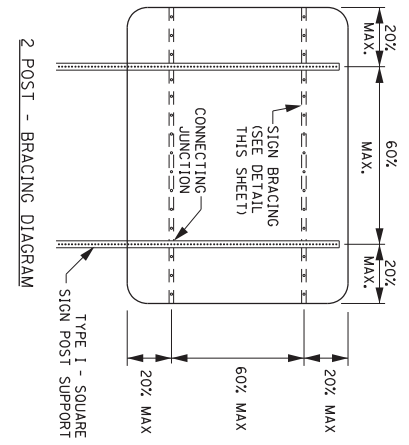

1 POST - BRACING DIAGRAM

NOTE:
USE OF SIGN BRACING NOT SHOWN ON THIS SHEET MAY BE PERMITTED
BY PROJECT ENGINEER AND/OR DISTRICT TRAFFIC ENGINEER.

NOT TO SCALE

SHEETING SIGN DETAIL
SHEET 2 OF 2

COUNTY OF	ITEM NO.	SHEET NO.

COUNTY OF	ITEM NO.	SHEET NO.

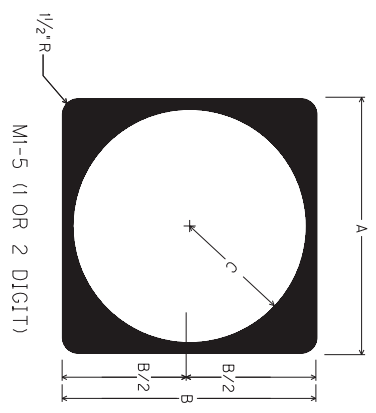
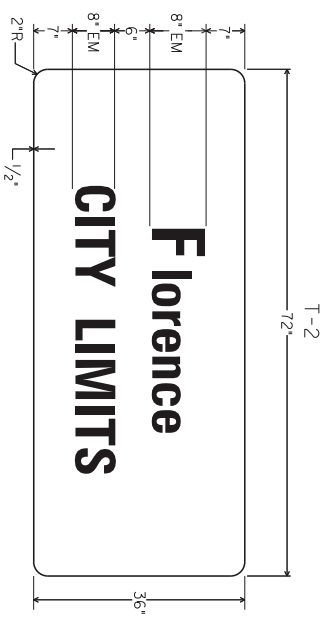
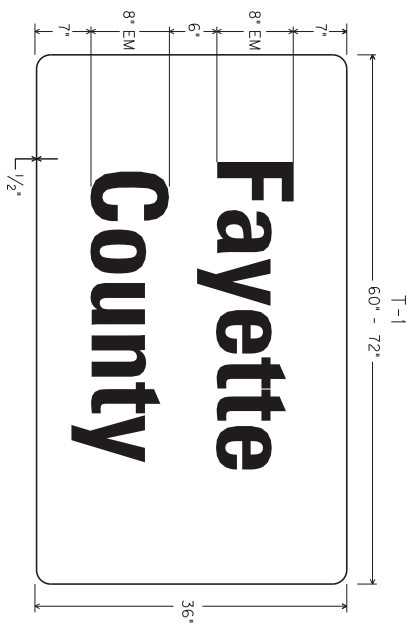

	A	B	C	FONT
CONVENTIONAL	24"	24"	11"	12D
EXPRESSWAY/ FREEWAY	36"	36"	17"	18D

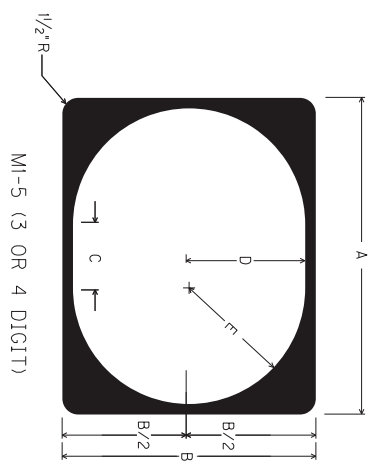

	A	B	C	D	E	FONT	
						3 DIGIT	4 DIGIT
CONVENTIONAL	30"	24"	6"	11"	11"	12D	12B
EXPRESSWAY/ FREEWAY	45"	36"	9"	16.5"	16.5"	18D	18B

NOTE: FOR ROUTE MARKERS, IF NECESSARY, ADJUSTMENTS TO THE DIGIT LAYOUT AND/OR FONT TYPE MAY BE MADE TO ENSURE VISUAL ACUITY

NOTE: EXPRESSWAY/FREEWAY DEFINED AS A DIVIDED HIGHWAY WITH PARTIAL OR FULL CONTROL OF ACCESS

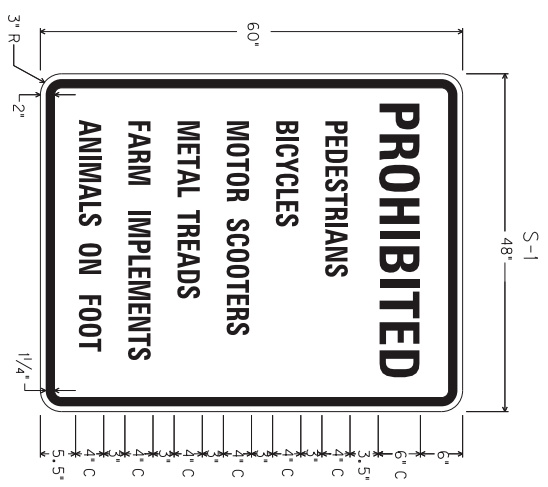

NOT TO SCALE

TYPICAL SIGNS

CHEVRON PAVEMENT MARKINGS DETAIL

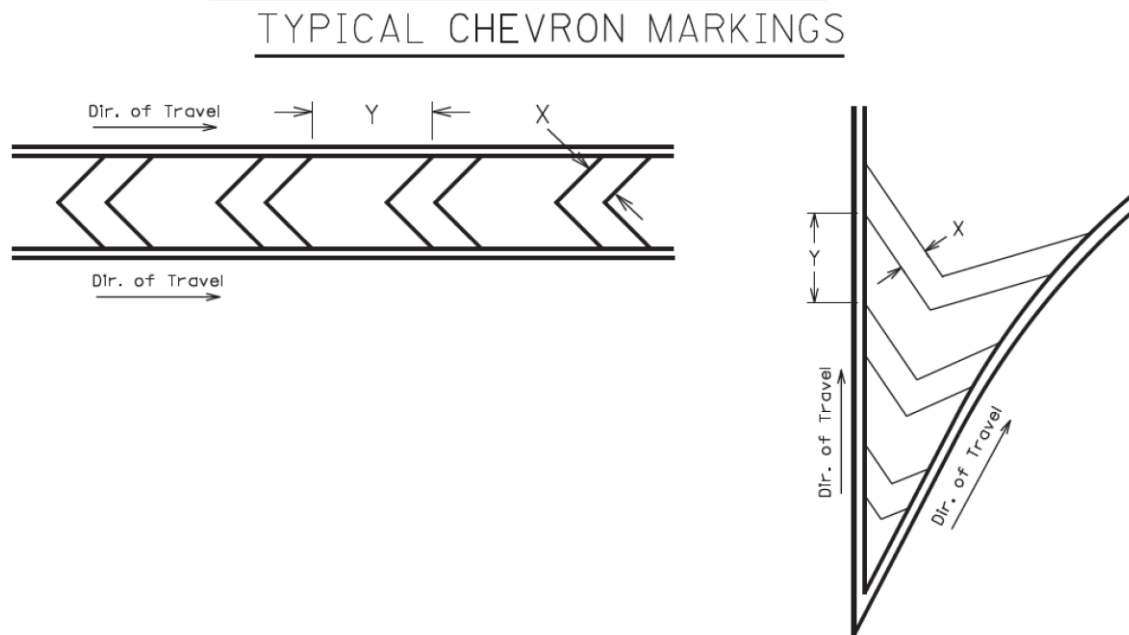

The chevron pavement marking width (X) and spacing (Y) will usually be specified in the plans. The width to spacing values usually have a ratio of 1:10. If the plans do not specify the width (X) and spacing (Y) the Engineer will provide the contractor with the X and Y values for each chevron installation. If necessary, the Engineer may obtain guidance from the District Traffic Engineer and/or the Division of Traffic Operations.

NOTE: Adjust the width and spacing of the chevron pavement markings as necessary so that a minimum of three (3) chevron markings are placed within the area being marked. The 1:10 ratio between width and spacing values should be maintained as much as possible.

Refer to Section 717 of the Standard Specifications for Road and Bridge Construction, current edition, for more information concerning Material and Construction specifications.

The Department will measure the finished in-place area of Chevron Pavement Markings in Square Feet. The Department will NOT measure overlaps or the void space between the chevrons. See Section 717.04 for additional measurement information.

When listed as a bid item, the Department will make payment for the completed and accepted quantities of Chevron Pavement Markings under the following:

<u>Code</u>	<u>Pay Item</u>	<u>Pay Unit</u>
24679ED	Pave Mark Thermo Chevron	Square Foot
26166ES717	Pave Mark TY 1 Tape Chevron	Square Foot

CROSS-HATCH PAVEMENT MARKINGS DETAIL

TYPICAL CROSS-HATCH MARKINGS

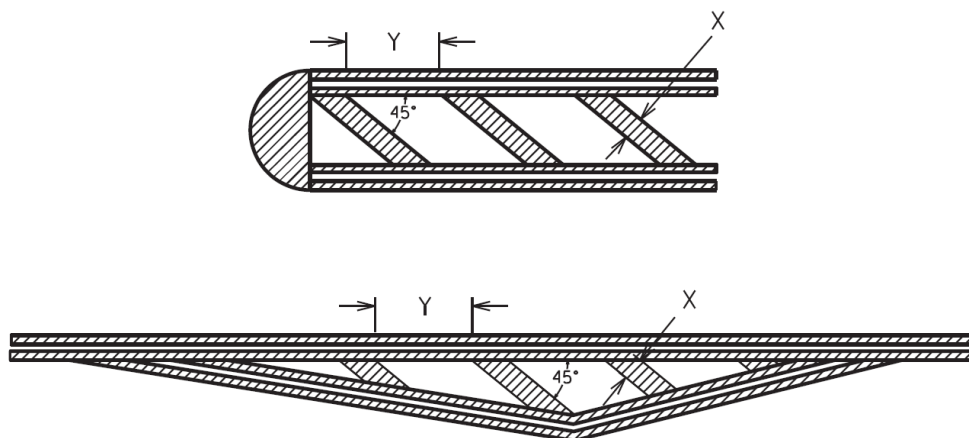

The cross-hatch pavement marking width (X) and spacing (Y) will usually be specified in the plans. The width to spacing values usually have a ratio of 1:10. If the plans do not specify the width (X) and spacing (Y) the Engineer will provide the contractor with the X and Y values for each cross-hatch installation. If necessary, the Engineer may obtain guidance from the District Traffic Engineer and/or the Division of Traffic Operations.

NOTE: Adjust the width and spacing of the cross-hatch pavement markings as necessary so that a minimum of three (3) cross-hatch markings are placed within the area being marked. The 1:10 ratio between width and spacing values should be maintained as much as possible.

Refer to Section 717 of the Standard Specifications for Road and Bridge Construction, current edition, for more information concerning Material and Construction specifications.

The Department will measure the finished in-place area of Cross-Hatch Pavement Markings in Square Feet. The Department will NOT measure overlaps or the void space between cross-hatching. See Section 717.04 for additional measurement information.

When listed in the bid items, the Department will make payment for the completed and accepted quantities of Cross-Hatch Pavement Markings under the following:

<u>Code</u>	<u>Pay Item</u>	<u>Pay Unit</u>
06569	Pave Marking-Thermo Cross-Hatch	Square Foot
23253ES717	Pave Mark TY 1 Tape Cross Hatch	Square Foot

PART II
SPECIFICATIONS AND STANDARD DRAWINGS

SPECIFICATIONS REFERENCE

Any reference in the plans or proposal to previous editions of the *Standard Specifications for Road and Bridge Construction* and *Standard Drawings* are superseded by *Standard Specifications for Road and Bridge Construction, Edition of 2019* and *Standard Drawings, Edition of 2020*.

SUPPLEMENTAL SPECIFICATIONS

The contractor shall use the Supplemental Specifications that are effective at the time of letting.
The Supplemental Specifications can be found at the following link:

<http://transportation.ky.gov/Construction/Pages/Kentucky-Standard-Specifications.aspx>

SPECIAL NOTE FOR PORTABLE CHANGEABLE MESSAGE SIGNS

This Special Note will apply when indicated on the plans or in the proposal.

1.0 DESCRIPTION. Furnish, install, operate, and maintain variable message signs at the locations shown on the plans or designated by the Engineer. Remove and retain possession of variable message signs when they are no longer needed on the project.

2.0 MATERIALS.

2.1 General. Use LED Variable Message Signs Class I, II, or III, as appropriate, from the Department's List of Approved Materials.

Unclassified signs may be submitted for approval by the Engineer. The Engineer may require a daytime and nighttime demonstration. The Engineer will make a final decision within 30 days after all required information is received.

2.2 Sign and Controls. All signs must:

- 1) Provide 3-line messages with each line being 8 characters long and at least 18 inches tall. Each character comprises 35 pixels.
- 2) Provide at least 40 preprogrammed messages available for use at any time. Provide for quick and easy change of the displayed message; editing of the message; and additions of new messages.
- 3) Provide a controller consisting of:
 - a) Keyboard or keypad.
 - b) Readout that mimics the actual sign display. (When LCD or LCD type readout is used, include backlighting and heating or otherwise arrange for viewing in cold temperatures.)
 - c) Non-volatile memory or suitable memory with battery backup for storing pre-programmed messages.
 - d) Logic circuitry to control the sequence of messages and flash rate.
- 4) Provide a serial interface that is capable of supporting complete remote control ability through land line and cellular telephone operation. Include communication software capable of immediately updating the message, providing complete sign status, and allowing message library queries and updates.
- 5) Allow a single person easily to raise the sign to a satisfactory height above the pavement during use, and lower the sign during travel.
- 6) Be Highway Orange on all exterior surfaces of the trailer, supports, and controller cabinet.
- 7) Provide operation in ambient temperatures from -30 to + 120 degrees Fahrenheit during snow, rain and other inclement weather.
- 8) Provide the driver board as part of a module. All modules are interchangeable, and have plug and socket arrangements for disconnection and reconnection. Printed circuit boards associated with driver boards have a conformable coating to protect against moisture.
- 9) Provide a sign case sealed against rain, snow, dust, insects, etc. The lens is UV stabilized clear plastic (polycarbonate, acrylic, or other approved material) angled to prevent glare.
- 10) Provide a flat black UV protected coating on the sign hardware, character PCB, and appropriate lens areas.
- 11) Provide a photocell control to provide automatic dimming.

- 12) Allow an on-off flashing sequence at an adjustable rate.
- 13) Provide a sight to aim the message.
- 14) Provide a LED display color of approximately 590 nm amber.
- 15) Provide a controller that is password protected.
- 16) Provide a security device that prevents unauthorized individuals from accessing the controller.
- 17) Provide the following 3-line messages preprogrammed and available for use when the sign unit begins operation:

/KEEP/RIGHT/=>=>=>/	/MIN/SPEED/**MPH/
/KEEP/LEFT/<=<=</	/ICY/BRIDGE/AHEAD/ /ONE
/LOOSE/GRAVEL/AHEAD/	LANE/BRIDGE/AHEAD/
/RD WORK/NEXT/**MILES/	/ROUGH/ROAD/AHEAD/
/TWO WAY/TRAFFIC/AHEAD/	/MERGING/TRAFFIC/AHEAD/
/PAINT/CREW/AHEAD/	/NEXT/**/MILES/
/REDUCE/SPEED/**MPH/	/HEAVY/TRAFFIC/AHEAD/
/BRIDGE/WORK/**0 FT/	/SPEED/LIMIT/**MPH/
/MAX/SPEED/**MPH/	/BUMP/AHEAD/
/SURVEY/PARTY/AHEAD/	/TWO/WAY/TRAFFIC/

*Insert numerals as directed by the Engineer.
Add other messages during the project when required by the Engineer.

2.3 Power.

- 1) Design solar panels to yield 10 percent or greater additional charge than sign consumption. Provide direct wiring for operation of the sign or arrow board from an external power source to provide energy backup for 21 days without sunlight and an on-board system charger with the ability to recharge completely discharged batteries in 24 hours.

3.0 CONSTRUCTION. Furnish and operate the variable message signs as designated on the plans or by the Engineer. Ensure the bottom of the message panel is a minimum of 7 feet above the roadway in urban areas and 5 feet above in rural areas when operating. Use Class I, II, or III signs on roads with a speed limit less than 55 mph. Use Class I or II signs on roads with speed limits 55 mph or greater.

Maintain the sign in proper working order, including repair of any damage done by others, until completion of the project. When the sign becomes inoperative, immediately repair or replace the sign. Repetitive problems with the same unit will be cause for rejection and replacement.

Use only project related messages and messages directed by the Engineer, unnecessary messages lessen the impact of the sign. Ensure the message is displayed in either one or 2 phases with each phase having no more than 3 lines of text. When no message is needed, but it is necessary to know if the sign is operable, flash only a pixel.

When the sign is not needed, move it outside the clear zone or where the Engineer directs. Variable Message Signs are the property of the Contractor and shall be removed from the project when no longer needed. The Department will not assume ownership of these signs.

4.0 MEASUREMENT. The final quantity of Variable Message Sign will be

11

the actual number of individual signs acceptably furnished and operated during the project. The Department will not measure signs replaced due to damage or rejection.

5.0 PAYMENT. The Department will pay for the Variable Message Signs at the unit price each. The Department will not pay for signs replaced due to damage or rejection. Payment is full compensation for furnishing all materials, labor, equipment, and service necessary to, operate, move, repair, and maintain or replace the variable message signs. The Department will make payment for the completed and accepted quantities under the following:

<u>Code</u>	<u>Pay Item</u>	<u>Pay Unit</u>
02671	Portable Changeable Message Sign	Each

Effective June 15, 2012

SPECIAL NOTE FOR BARCODE LABEL ON PERMANENT SIGNS

1.0 DESCRIPTION. Install barcode label on sheeting signs. Section references herein are to the Department’s Standard Specifications for Road and Bridge Construction, current edition.

2.0 MATERIALS. The Department will provide the Contractor with a 2 inch x 1 inch foil barcode label for each permanent sheeting sign. A unique number will be assigned to each barcode label.

The Contractor shall contact the Operations and Pavement Management Branch in the Division of Maintenance at (502) 564-4556 to obtain the barcode labels.

3.0 CONSTRUCTION. Apply foil barcode label in the lower right quadrant of the sign back. Signs where the bottom edge is not parallel to the ground, the lowest corner of the sign shall serve as the location to place the barcode label. The barcode label shall be placed no less than one-inch and no more than three inches from any edge of the sign. The barcode must be placed so that the sign post does not cover the barcode label.

Barcodes shall be applied in an indoor setting with a minimum air temperature of 50°F or higher. Prior to application of the barcode label, the back of the sign must be clean and free of dust, oil, etc. If the sign is not clean, an alcohol swab shall be used to clean the area. The area must be allowed to dry prior to placement of the barcode label.

Data for each sign shall include the barcode number, MUTCD reference number, sheeting manufacturer, sheeting type, manufacture date, color of primary reflective surface, installation date, latitude and longitude using the North American Datum of 1983 (NAD83) or the State Plane Coordinates using an x and y ordinate of the installed location.

Data should be provided electronically on the TC 71-229 Sign Details Information and TC 71-230 Sign Assembly Information forms. The Contractor may choose to present the data in a different format provided that the information submitted to the Department is equivalent to the information required on the Department TC forms. The forms must be submitted in electronic format regardless of which type of form is used. The Department will not accept PDF or handwritten forms. These completed forms must be submitted to the Department prior to final inspection of the signs. The Department will not issue formal acceptance for the project until the TC 71-229 and TC-230 electronic forms are completed for all signs and sign assemblies on the project.

4.0 MEASUREMENT. The Department will measure all work required for the installation of the barcode label and all work associated with completion and submission of the sign inventory data (TC 71-229 and TC 71-230).

The installation of the permanent sign will be measured in accordance to Section 715.

5.0 PAYMENT. The Department will make payment for the completed and accepted quantities under the following:

<u>Code</u>	<u>Pay Item</u>	<u>Pay Unit</u>
24631EC	Barcode Sign Inventory	Each

The Department will not make payment for this item until all barcodes are installed and sign inventory is complete on every permanent sign installed on the project. The Department will make payment for installation of the permanent sign in accordance to Section 715. The Department will consider payment as full compensation for all work required under this special note.

One Sign Post



↑
2" Wide Post

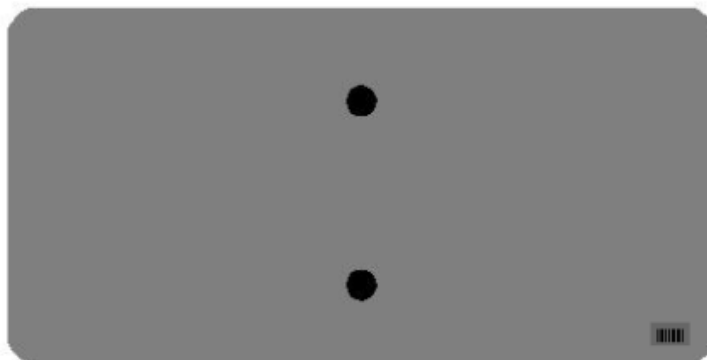
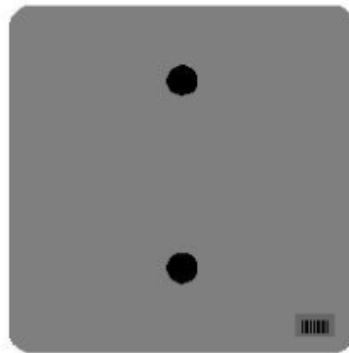

One Sign Post

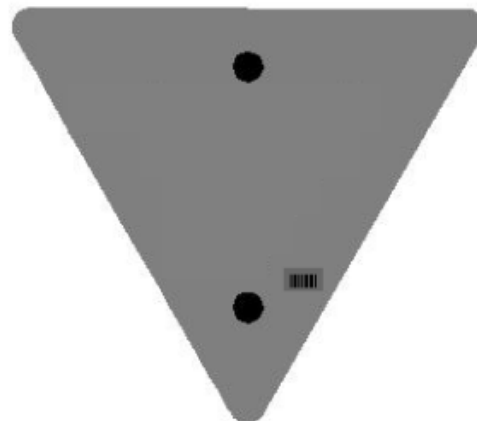
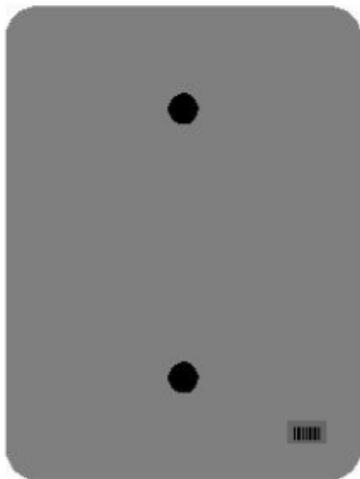
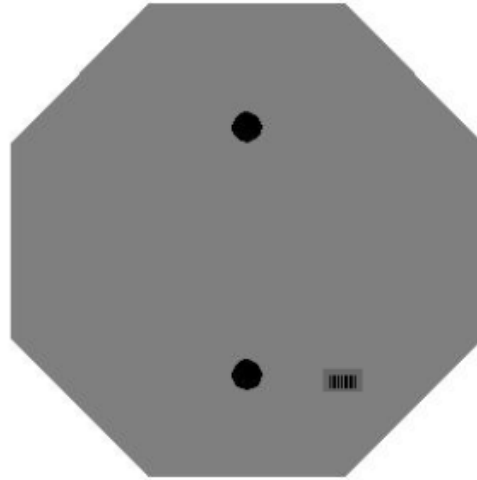
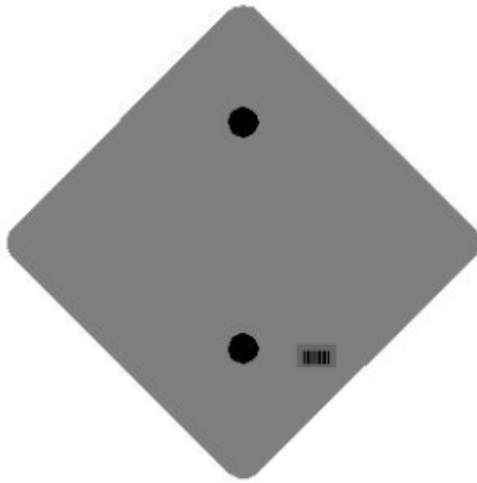

One Sign Post

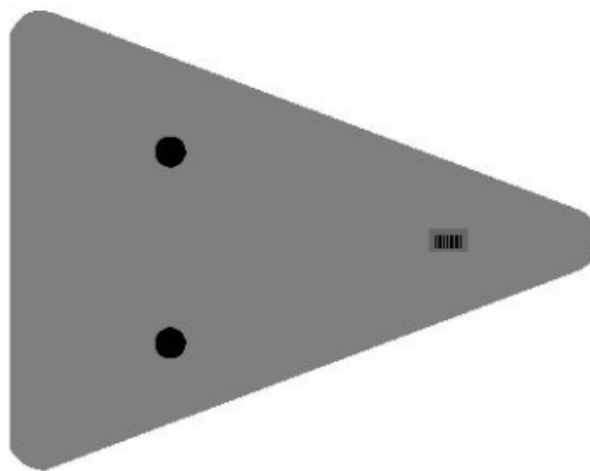
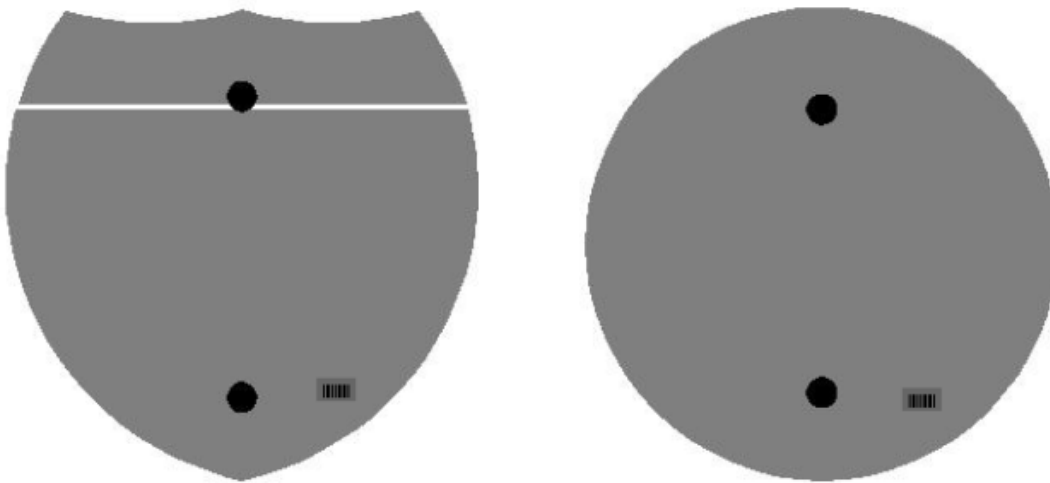

Double Sign Post

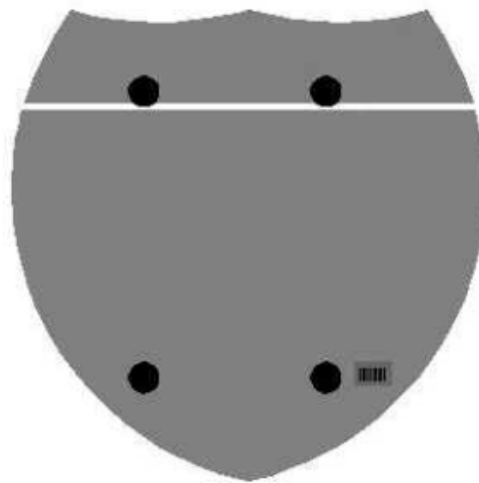

Interstate
Shield

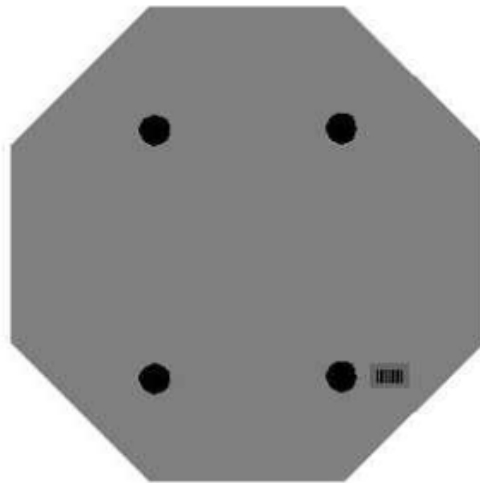

48" Stop

2 Post Signs



↑
2" Wide Post

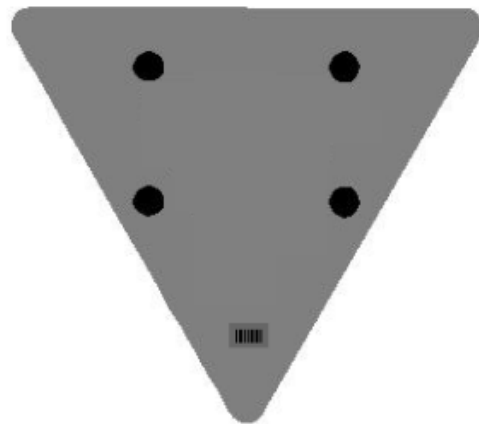

2020 STANDARD DRAWINGS THAT APPLY

ROADWAY

MISCELLANEOUS DRAINAGE

SILT TRAP - TYPE A	RDX-220-05
SILT TRAP - TYPE B	RDX-225-01
SILT TRAP - TYPE C	RDX-230-01

~ PAVEMENT ~

MEDIANS, CURBS, APPROACHES, ENTRANCES, ETC.

STANDARD BARRIER MEDIAN.....	RPM-010-06
------------------------------	------------

~ TEMPORARY ~

TRAFFIC CONTROL

LANE CLOSURE TWO-LANE HIGHWAY.....	TTC-100-05
SHOULDER CLOSURE	TTC-135-03

STRIPING OPERATIONS

MOBILE OPERATION FOR PAINT STRIPING CASE I.....	TTS-100-02
MOBILE OPERATION FOR PAINT STRIPING CASE II.....	TTS-105-02
MOBILE OPERATION FOR PAINT STRIPING CASE III.....	TTS-110-02
MOBILE OPERATION FOR PAINT STRIPING CASE IV	TTS-115-02

PART III

EMPLOYMENT, WAGE AND RECORD REQUIREMENTS

FHWA-1273 -- Revised May 1, 2012

REQUIRED CONTRACT PROVISIONS FEDERAL-AID CONSTRUCTION CONTRACTS

- I. General
- II. Nondiscrimination
- III. Nonsegregated Facilities
- IV. Davis-Bacon and Related Act Provisions
- V. Contract Work Hours and Safety Standards Act Provisions
- VI. Subletting or Assigning the Contract
- VII. Safety: Accident Prevention
- VIII. False Statements Concerning Highway Projects
- IX. Implementation of Clean Air Act and Federal Water Pollution Control Act
- X. Compliance with Governmentwide Suspension and Debarment Requirements
- XI. Certification Regarding Use of Contract Funds for Lobbying

ATTACHMENTS

A. Employment and Materials Preference for Appalachian Development Highway System or Appalachian Local Access Road Contracts (included in Appalachian contracts only)

I. GENERAL

1. Form FHWA-1273 must be physically incorporated in each construction contract funded under Title 23 (excluding emergency contracts solely intended for debris removal). The contractor (or subcontractor) must insert this form in each subcontract and further require its inclusion in all lower tier subcontracts (excluding purchase orders, rental agreements and other agreements for supplies or services).

The applicable requirements of Form FHWA-1273 are incorporated by reference for work done under any purchase order, rental agreement or agreement for other services. The prime contractor shall be responsible for compliance by any subcontractor, lower-tier subcontractor or service provider.

Form FHWA-1273 must be included in all Federal-aid design-build contracts, in all subcontracts and in lower tier subcontracts (excluding subcontracts for design services, purchase orders, rental agreements and other agreements for supplies or services). The design-builder shall be responsible for compliance by any subcontractor, lower-tier subcontractor or service provider.

Contracting agencies may reference Form FHWA-1273 in bid proposal or request for proposal documents, however, the Form FHWA-1273 must be physically incorporated (not referenced) in all contracts, subcontracts and lower-tier subcontracts (excluding purchase orders, rental agreements and other agreements for supplies or services related to a construction contract).

2. Subject to the applicability criteria noted in the following sections, these contract provisions shall apply to all work performed on the contract by the contractor's own organization and with the assistance of workers under the contractor's immediate superintendence and to all work performed on the contract by piecework, station work, or by subcontract.

3. A breach of any of the stipulations contained in these Required Contract Provisions may be sufficient grounds for withholding of progress payments, withholding of final payment, termination of the contract, suspension / debarment or any other action determined to be appropriate by the contracting agency and FHWA.

4. Selection of Labor: During the performance of this contract, the contractor shall not use convict labor for any purpose within the limits of a construction project on a Federal-aid highway unless it is labor performed by convicts who are on parole, supervised release, or probation. The term Federal-aid highway does not include roadways functionally classified as local roads or rural minor collectors.

II. NONDISCRIMINATION

The provisions of this section related to 23 CFR Part 230 are applicable to all Federal-aid construction contracts and to all related construction subcontracts of \$10,000 or more. The provisions of 23 CFR Part 230 are not applicable to material supply, engineering, or architectural service contracts.

In addition, the contractor and all subcontractors must comply with the following policies: Executive Order 11246, 41 CFR 60, 29 CFR 1625-1627, Title 23 USC Section 140, the Rehabilitation Act of 1973, as amended (29 USC 794), Title VI of the Civil Rights Act of 1964, as amended, and related regulations including 49 CFR Parts 21, 26 and 27; and 23 CFR Parts 200, 230, and 633.

The contractor and all subcontractors must comply with: the requirements of the Equal Opportunity Clause in 41 CFR 60-1.4(b) and, for all construction contracts exceeding \$10,000, the Standard Federal Equal Employment Opportunity Construction Contract Specifications in 41 CFR 60-4.3.

Note: The U.S. Department of Labor has exclusive authority to determine compliance with Executive Order 11246 and the policies of the Secretary of Labor including 41 CFR 60, and 29 CFR 1625-1627. The contracting agency and the FHWA have the authority and the responsibility to ensure compliance with Title 23 USC Section 140, the Rehabilitation Act of 1973, as amended (29 USC 794), and Title VI of the Civil Rights Act of 1964, as amended, and related regulations including 49 CFR Parts 21, 26 and 27; and 23 CFR Parts 200, 230, and 633.

The following provision is adopted from 23 CFR 230, Appendix A, with appropriate revisions to conform to the U.S. Department of Labor (US DOL) and FHWA requirements.

1. Equal Employment Opportunity: Equal employment opportunity (EEO) requirements not to discriminate and to take affirmative action to assure equal opportunity as set forth under laws, executive orders, rules, regulations (28 CFR 35, 29 CFR 1630, 29 CFR 1625-1627, 41 CFR 60 and 49 CFR 27) and orders of the Secretary of Labor as modified by the provisions prescribed herein, and imposed pursuant to 23 U.S.C. 140 shall constitute the EEO and specific affirmative action standards for the contractor's project activities under

this contract. The provisions of the Americans with Disabilities Act of 1990 (42 U.S.C. 12101 et seq.) set forth under 28 CFR 35 and 29 CFR 1630 are incorporated by reference in this contract. In the execution of this contract, the contractor agrees to comply with the following minimum specific requirement activities of EEO:

a. The contractor will work with the contracting agency and the Federal Government to ensure that it has made every good faith effort to provide equal opportunity with respect to all of its terms and conditions of employment and in their review of activities under the contract.

b. The contractor will accept as its operating policy the following statement:

"It is the policy of this Company to assure that applicants are employed, and that employees are treated during employment, without regard to their race, religion, sex, color, national origin, age or disability. Such action shall include: employment, upgrading, demotion, or transfer; recruitment or recruitment advertising; layoff or termination; rates of pay or other forms of compensation; and selection for training, including apprenticeship, pre-apprenticeship, and/or on-the-job training."

2. EEO Officer: The contractor will designate and make known to the contracting officers an EEO Officer who will have the responsibility for and must be capable of effectively administering and promoting an active EEO program and who must be assigned adequate authority and responsibility to do so.

3. Dissemination of Policy: All members of the contractor's staff who are authorized to hire, supervise, promote, and discharge employees, or who recommend such action, or who are substantially involved in such action, will be made fully cognizant of, and will implement, the contractor's EEO policy and contractual responsibilities to provide EEO in each grade and classification of employment. To ensure that the above agreement will be met, the following actions will be taken as a minimum:

a. Periodic meetings of supervisory and personnel office employees will be conducted before the start of work and then not less often than once every six months, at which time the contractor's EEO policy and its implementation will be reviewed and explained. The meetings will be conducted by the EEO Officer.

b. All new supervisory or personnel office employees will be given a thorough indoctrination by the EEO Officer, covering all major aspects of the contractor's EEO obligations within thirty days following their reporting for duty with the contractor.

c. All personnel who are engaged in direct recruitment for the project will be instructed by the EEO Officer in the contractor's procedures for locating and hiring minorities and women.

d. Notices and posters setting forth the contractor's EEO policy will be placed in areas readily accessible to employees, applicants for employment and potential employees.

e. The contractor's EEO policy and the procedures to implement such policy will be brought to the attention of employees by means of meetings, employee handbooks, or other appropriate means.

4. Recruitment: When advertising for employees, the contractor will include in all advertisements for employees the notation: "An Equal Opportunity Employer." All such advertisements will be placed in publications having a large circulation among minorities and women in the area from which the project work force would normally be derived.

a. The contractor will, unless precluded by a valid bargaining agreement, conduct systematic and direct recruitment through public and private employee referral sources likely to yield qualified minorities and women. To meet this requirement, the contractor will identify sources of potential minority group employees, and establish with such identified sources procedures whereby minority and women applicants may be referred to the contractor for employment consideration.

b. In the event the contractor has a valid bargaining agreement providing for exclusive hiring hall referrals, the contractor is expected to observe the provisions of that agreement to the extent that the system meets the contractor's compliance with EEO contract provisions. Where implementation of such an agreement has the effect of discriminating against minorities or women, or obligates the contractor to do the same, such implementation violates Federal nondiscrimination provisions.

c. The contractor will encourage its present employees to refer minorities and women as applicants for employment. Information and procedures with regard to referring such applicants will be discussed with employees.

5. Personnel Actions: Wages, working conditions, and employee benefits shall be established and administered, and personnel actions of every type, including hiring, upgrading, promotion, transfer, demotion, layoff, and termination, shall be taken without regard to race, color, religion, sex, national origin, age or disability. The following procedures shall be followed:

a. The contractor will conduct periodic inspections of project sites to insure that working conditions and employee facilities do not indicate discriminatory treatment of project site personnel.

b. The contractor will periodically evaluate the spread of wages paid within each classification to determine any evidence of discriminatory wage practices.

c. The contractor will periodically review selected personnel actions in depth to determine whether there is evidence of discrimination. Where evidence is found, the contractor will promptly take corrective action. If the review indicates that the discrimination may extend beyond the actions reviewed, such corrective action shall include all affected persons.

d. The contractor will promptly investigate all complaints of alleged discrimination made to the contractor in connection with its obligations under this contract, will attempt to resolve such complaints, and will take appropriate corrective action within a reasonable time. If the investigation indicates that the discrimination may affect persons other than the complainant, such corrective action shall include such other persons. Upon completion of each investigation, the contractor will inform every complainant of all of their avenues of appeal.

6. Training and Promotion:

a. The contractor will assist in locating, qualifying, and increasing the skills of minorities and women who are

applicants for employment or current employees. Such efforts should be aimed at developing full journey level status employees in the type of trade or job classification involved.

b. Consistent with the contractor's work force requirements and as permissible under Federal and State regulations, the contractor shall make full use of training programs, i.e., apprenticeship, and on-the-job training programs for the geographical area of contract performance. In the event a special provision for training is provided under this contract, this subparagraph will be superseded as indicated in the special provision. The contracting agency may reserve training positions for persons who receive welfare assistance in accordance with 23 U.S.C. 140(a).

c. The contractor will advise employees and applicants for employment of available training programs and entrance requirements for each.

d. The contractor will periodically review the training and promotion potential of employees who are minorities and women and will encourage eligible employees to apply for such training and promotion.

7. Unions: If the contractor relies in whole or in part upon unions as a source of employees, the contractor will use good faith efforts to obtain the cooperation of such unions to increase opportunities for minorities and women. Actions by the contractor, either directly or through a contractor's association acting as agent, will include the procedures set forth below:

a. The contractor will use good faith efforts to develop, in cooperation with the unions, joint training programs aimed toward qualifying more minorities and women for membership in the unions and increasing the skills of minorities and women so that they may qualify for higher paying employment.

b. The contractor will use good faith efforts to incorporate an EEO clause into each union agreement to the end that such union will be contractually bound to refer applicants without regard to their race, color, religion, sex, national origin, age or disability.

c. The contractor is to obtain information as to the referral practices and policies of the labor union except that to the extent such information is within the exclusive possession of the labor union and such labor union refuses to furnish such information to the contractor, the contractor shall so certify to the contracting agency and shall set forth what efforts have been made to obtain such information.

d. In the event the union is unable to provide the contractor with a reasonable flow of referrals within the time limit set forth in the collective bargaining agreement, the contractor will, through independent recruitment efforts, fill the employment vacancies without regard to race, color, religion, sex, national origin, age or disability; making full efforts to obtain qualified and/or qualifiable minorities and women. The failure of a union to provide sufficient referrals (even though it is obligated to provide exclusive referrals under the terms of a collective bargaining agreement) does not relieve the contractor from the requirements of this paragraph. In the event the union referral practice prevents the contractor from meeting the obligations pursuant to Executive Order 11246, as amended, and these special provisions, such contractor shall immediately notify the contracting agency.

8. Reasonable Accommodation for Applicants / Employees with Disabilities: The contractor must be familiar

with the requirements for and comply with the Americans with Disabilities Act and all rules and regulations established there under. Employers must provide reasonable accommodation in all employment activities unless to do so would cause an undue hardship.

9. Selection of Subcontractors, Procurement of Materials and Leasing of Equipment: The contractor shall not discriminate on the grounds of race, color, religion, sex, national origin, age or disability in the selection and retention of subcontractors, including procurement of materials and leases of equipment. The contractor shall take all necessary and reasonable steps to ensure nondiscrimination in the administration of this contract.

a. The contractor shall notify all potential subcontractors and suppliers and lessors of their EEO obligations under this contract.

b. The contractor will use good faith efforts to ensure subcontractor compliance with their EEO obligations.

10. Assurance Required by 49 CFR 26.13(b):

a. The requirements of 49 CFR Part 26 and the State DOT's U.S. DOT-approved DBE program are incorporated by reference.

b. The contractor or subcontractor shall not discriminate on the basis of race, color, national origin, or sex in the performance of this contract. The contractor shall carry out applicable requirements of 49 CFR Part 26 in the award and administration of DOT-assisted contracts. Failure by the contractor to carry out these requirements is a material breach of this contract, which may result in the termination of this contract or such other remedy as the contracting agency deems appropriate.

11. Records and Reports: The contractor shall keep such records as necessary to document compliance with the EEO requirements. Such records shall be retained for a period of three years following the date of the final payment to the contractor for all contract work and shall be available at reasonable times and places for inspection by authorized representatives of the contracting agency and the FHWA.

a. The records kept by the contractor shall document the following:

(1) The number and work hours of minority and non-minority group members and women employed in each work classification on the project;

(2) The progress and efforts being made in cooperation with unions, when applicable, to increase employment opportunities for minorities and women; and

(3) The progress and efforts being made in locating, hiring, training, qualifying, and upgrading minorities and women;

b. The contractors and subcontractors will submit an annual report to the contracting agency each July for the duration of the project, indicating the number of minority, women, and non-minority group employees currently engaged in each work classification required by the contract work. This information is to be reported on [Form FHWA-1391](#). The staffing data should represent the project work force on board in all or any part of the last payroll period preceding the end of July. If on-the-job training is being required by special provision, the contractor

will be required to collect and report training data. The employment data should reflect the work force on board during all or any part of the last payroll period preceding the end of July.

III. NONSEGREGATED FACILITIES

This provision is applicable to all Federal-aid construction contracts and to all related construction subcontracts of \$10,000 or more.

The contractor must ensure that facilities provided for employees are provided in such a manner that segregation on the basis of race, color, religion, sex, or national origin cannot result. The contractor may neither require such segregated use by written or oral policies nor tolerate such use by employee custom. The contractor's obligation extends further to ensure that its employees are not assigned to perform their services at any location, under the contractor's control, where the facilities are segregated. The term "facilities" includes waiting rooms, work areas, restaurants and other eating areas, time clocks, restrooms, washrooms, locker rooms, and other storage or dressing areas, parking lots, drinking fountains, recreation or entertainment areas, transportation, and housing provided for employees. The contractor shall provide separate or single-user restrooms and necessary dressing or sleeping areas to assure privacy between sexes.

IV. DAVIS-BACON AND RELATED ACT PROVISIONS

This section is applicable to all Federal-aid construction projects exceeding \$2,000 and to all related subcontracts and lower-tier subcontracts (regardless of subcontract size). The requirements apply to all projects located within the right-of-way of a roadway that is functionally classified as Federal-aid highway. This excludes roadways functionally classified as local roads or rural minor collectors, which are exempt. Contracting agencies may elect to apply these requirements to other projects.

The following provisions are from the U.S. Department of Labor regulations in 29 CFR 5.5 "Contract provisions and related matters" with minor revisions to conform to the FHWA-1273 format and FHWA program requirements.

1. Minimum wages

a. All laborers and mechanics employed or working upon the site of the work, will be paid unconditionally and not less often than once a week, and without subsequent deduction or rebate on any account (except such payroll deductions as are permitted by regulations issued by the Secretary of Labor under the Copeland Act (29 CFR part 3)), the full amount of wages and bona fide fringe benefits (or cash equivalents thereof) due at time of payment computed at rates not less than those contained in the wage determination of the Secretary of Labor which is attached hereto and made a part hereof, regardless of any contractual relationship which may be alleged to exist between the contractor and such laborers and mechanics.

Contributions made or costs reasonably anticipated for bona fide fringe benefits under section 1(b)(2) of the Davis-Bacon Act on behalf of laborers or mechanics are considered wages paid to such laborers or mechanics, subject to the provisions

of paragraph 1.d. of this section; also, regular contributions made or costs incurred for more than a weekly period (but not less often than quarterly) under plans, funds, or programs which cover the particular weekly period, are deemed to be constructively made or incurred during such weekly period. Such laborers and mechanics shall be paid the appropriate wage rate and fringe benefits on the wage determination for the classification of work actually performed, without regard to skill, except as provided in 29 CFR 5.5(a)(4). Laborers or mechanics performing work in more than one classification may be compensated at the rate specified for each classification for the time actually worked therein: Provided, That the employer's payroll records accurately set forth the time spent in each classification in which work is performed. The wage determination (including any additional classification and wage rates conformed under paragraph 1.b. of this section) and the Davis-Bacon poster (WH-1321) shall be posted at all times by the contractor and its subcontractors at the site of the work in a prominent and accessible place where it can be easily seen by the workers.

b.(1) The contracting officer shall require that any class of laborers or mechanics, including helpers, which is not listed in the wage determination and which is to be employed under the contract shall be classified in conformance with the wage determination. The contracting officer shall approve an additional classification and wage rate and fringe benefits therefore only when the following criteria have been met:

- (i) The work to be performed by the classification requested is not performed by a classification in the wage determination; and
- (ii) The classification is utilized in the area by the construction industry; and
- (iii) The proposed wage rate, including any bona fide fringe benefits, bears a reasonable relationship to the wage rates contained in the wage determination.

(2) If the contractor and the laborers and mechanics to be employed in the classification (if known), or their representatives, and the contracting officer agree on the classification and wage rate (including the amount designated for fringe benefits where appropriate), a report of the action taken shall be sent by the contracting officer to the Administrator of the Wage and Hour Division, Employment Standards Administration, U.S. Department of Labor, Washington, DC 20210. The Administrator, or an authorized representative, will approve, modify, or disapprove every additional classification action within 30 days of receipt and so advise the contracting officer or will notify the contracting officer within the 30-day period that additional time is necessary.

(3) In the event the contractor, the laborers or mechanics to be employed in the classification or their representatives, and the contracting officer do not agree on the proposed classification and wage rate (including the amount designated for fringe benefits, where appropriate), the contracting officer shall refer the questions, including the views of all interested parties and the recommendation of the contracting officer, to the Wage and Hour Administrator for determination. The Wage and Hour Administrator, or an authorized representative, will issue a determination within 30 days of receipt and so advise the contracting officer or

will notify the contracting officer within the 30-day period that additional time is necessary.

(4) The wage rate (including fringe benefits where appropriate) determined pursuant to paragraphs 1.b.(2) or 1.b.(3) of this section, shall be paid to all workers performing work in the classification under this contract from the first day on which work is performed in the classification.

c. Whenever the minimum wage rate prescribed in the contract for a class of laborers or mechanics includes a fringe benefit which is not expressed as an hourly rate, the contractor shall either pay the benefit as stated in the wage determination or shall pay another bona fide fringe benefit or an hourly cash equivalent thereof.

d. If the contractor does not make payments to a trustee or other third person, the contractor may consider as part of the wages of any laborer or mechanic the amount of any costs reasonably anticipated in providing bona fide fringe benefits under a plan or program. Provided, That the Secretary of Labor has found, upon the written request of the contractor, that the applicable standards of the Davis-Bacon Act have been met. The Secretary of Labor may require the contractor to set aside in a separate account assets for the meeting of obligations under the plan or program.

2. Withholding

The contracting agency shall upon its own action or upon written request of an authorized representative of the Department of Labor, withhold or cause to be withheld from the contractor under this contract, or any other Federal contract with the same prime contractor, or any other federally-assisted contract subject to Davis-Bacon prevailing wage requirements, which is held by the same prime contractor, so much of the accrued payments or advances as may be considered necessary to pay laborers and mechanics, including apprentices, trainees, and helpers, employed by the contractor or any subcontractor the full amount of wages required by the contract. In the event of failure to pay any laborer or mechanic, including any apprentice, trainee, or helper, employed or working on the site of the work, all or part of the wages required by the contract, the contracting agency may, after written notice to the contractor, take such action as may be necessary to cause the suspension of any further payment, advance, or guarantee of funds until such violations have ceased.

3. Payrolls and basic records

a. Payrolls and basic records relating thereto shall be maintained by the contractor during the course of the work and preserved for a period of three years thereafter for all laborers and mechanics working at the site of the work. Such records shall contain the name, address, and social security number of each such worker, his or her correct classification, hourly rates of wages paid (including rates of contributions or costs anticipated for bona fide fringe benefits or cash equivalents thereof of the types described in section 1(b)(2)(B) of the Davis-Bacon Act), daily and weekly number of hours worked, deductions made and actual wages paid. Whenever the Secretary of Labor has found under 29 CFR 5.5(a)(1)(iv) that the wages of any laborer or mechanic include the amount of any costs reasonably anticipated in providing benefits under a plan or program described in section 1(b)(2)(B) of the Davis-

Bacon Act, the contractor shall maintain records which show that the commitment to provide such benefits is enforceable, that the plan or program is financially responsible, and that the plan or program has been communicated in writing to the laborers or mechanics affected, and records which show the costs anticipated or the actual cost incurred in providing such benefits. Contractors employing apprentices or trainees under approved programs shall maintain written evidence of the registration of apprenticeship programs and certification of trainee programs, the registration of the apprentices and trainees, and the ratios and wage rates prescribed in the applicable programs.

b.(1) The contractor shall submit weekly for each week in which any contract work is performed a copy of all payrolls to the contracting agency. The payrolls submitted shall set out accurately and completely all of the information required to be maintained under 29 CFR 5.5(a)(3)(i), except that full social security numbers and home addresses shall not be included on weekly transmittals. Instead the payrolls shall only need to include an individually identifying number for each employee (e.g., the last four digits of the employee's social security number). The required weekly payroll information may be submitted in any form desired. Optional Form WH-347 is available for this purpose from the Wage and Hour Division Web site at <http://www.dol.gov/esa/whd/forms/wh347instr.htm> or its successor site. The prime contractor is responsible for the submission of copies of payrolls by all subcontractors. Contractors and subcontractors shall maintain the full social security number and current address of each covered worker, and shall provide them upon request to the contracting agency for transmission to the State DOT, the FHWA or the Wage and Hour Division of the Department of Labor for purposes of an investigation or audit of compliance with prevailing wage requirements. It is not a violation of this section for a prime contractor to require a subcontractor to provide addresses and social security numbers to the prime contractor for its own records, without weekly submission to the contracting agency..

(2) Each payroll submitted shall be accompanied by a "Statement of Compliance," signed by the contractor or subcontractor or his or her agent who pays or supervises the payment of the persons employed under the contract and shall certify the following:

(i) That the payroll for the payroll period contains the information required to be provided under §5.5 (a)(3)(ii) of Regulations, 29 CFR part 5, the appropriate information is being maintained under §5.5 (a)(3)(i) of Regulations, 29 CFR part 5, and that such information is correct and complete;

(ii) That each laborer or mechanic (including each helper, apprentice, and trainee) employed on the contract during the payroll period has been paid the full weekly wages earned, without rebate, either directly or indirectly, and that no deductions have been made either directly or indirectly from the full wages earned, other than permissible deductions as set forth in Regulations, 29 CFR part 3;

(iii) That each laborer or mechanic has been paid not less than the applicable wage rates and fringe benefits or cash equivalents for the classification of work performed, as specified in the applicable wage determination incorporated into the contract.

(3) The weekly submission of a properly executed certification set forth on the reverse side of Optional Form WH-347 shall satisfy the requirement for submission of the "Statement of Compliance" required by paragraph 3.b.(2) of this section.

(4) The falsification of any of the above certifications may subject the contractor or subcontractor to civil or criminal prosecution under section 1001 of title 18 and section 231 of title 31 of the United States Code.

c. The contractor or subcontractor shall make the records required under paragraph 3.a. of this section available for inspection, copying, or transcription by authorized representatives of the contracting agency, the State DOT, the FHWA, or the Department of Labor, and shall permit such representatives to interview employees during working hours on the job. If the contractor or subcontractor fails to submit the required records or to make them available, the FHWA may, after written notice to the contractor, the contracting agency or the State DOT, take such action as may be necessary to cause the suspension of any further payment, advance, or guarantee of funds. Furthermore, failure to submit the required records upon request or to make such records available may be grounds for debarment action pursuant to 29 CFR 5.12.

4. Apprentices and trainees

a. Apprentices (programs of the USDOL).

Apprentices will be permitted to work at less than the predetermined rate for the work they performed when they are employed pursuant to and individually registered in a bona fide apprenticeship program registered with the U.S. Department of Labor, Employment and Training Administration, Office of Apprenticeship Training, Employer and Labor Services, or with a State Apprenticeship Agency recognized by the Office, or if a person is employed in his or her first 90 days of probationary employment as an apprentice in such an apprenticeship program, who is not individually registered in the program, but who has been certified by the Office of Apprenticeship Training, Employer and Labor Services or a State Apprenticeship Agency (where appropriate) to be eligible for probationary employment as an apprentice.

The allowable ratio of apprentices to journeymen on the job site in any craft classification shall not be greater than the ratio permitted to the contractor as to the entire work force under the registered program. Any worker listed on a payroll at an apprentice wage rate, who is not registered or otherwise employed as stated above, shall be paid not less than the applicable wage rate on the wage determination for the classification of work actually performed. In addition, any apprentice performing work on the job site in excess of the ratio permitted under the registered program shall be paid not less than the applicable wage rate on the wage determination for the work actually performed. Where a contractor is performing construction on a project in a locality other than that in which its program is registered, the ratios and wage rates (expressed in percentages of the journeyman's hourly rate) specified in the contractor's or subcontractor's registered program shall be observed.

Every apprentice must be paid at not less than the rate specified in the registered program for the apprentice's level of progress, expressed as a percentage of the journeymen hourly

rate specified in the applicable wage determination. Apprentices shall be paid fringe benefits in accordance with the provisions of the apprenticeship program. If the apprenticeship program does not specify fringe benefits, apprentices must be paid the full amount of fringe benefits listed on the wage determination for the applicable classification. If the Administrator determines that a different practice prevails for the applicable apprentice classification, fringes shall be paid in accordance with that determination.

In the event the Office of Apprenticeship Training, Employer and Labor Services, or a State Apprenticeship Agency recognized by the Office, withdraws approval of an apprenticeship program, the contractor will no longer be permitted to utilize apprentices at less than the applicable predetermined rate for the work performed until an acceptable program is approved.

b. Trainees (programs of the USDOL).

Except as provided in 29 CFR 5.16, trainees will not be permitted to work at less than the predetermined rate for the work performed unless they are employed pursuant to and individually registered in a program which has received prior approval, evidenced by formal certification by the U.S. Department of Labor, Employment and Training Administration.

The ratio of trainees to journeymen on the job site shall not be greater than permitted under the plan approved by the Employment and Training Administration.

Every trainee must be paid at not less than the rate specified in the approved program for the trainee's level of progress, expressed as a percentage of the journeyman hourly rate specified in the applicable wage determination. Trainees shall be paid fringe benefits in accordance with the provisions of the trainee program. If the trainee program does not mention fringe benefits, trainees shall be paid the full amount of fringe benefits listed on the wage determination unless the Administrator of the Wage and Hour Division determines that there is an apprenticeship program associated with the corresponding journeyman wage rate on the wage determination which provides for less than full fringe benefits for apprentices. Any employee listed on the payroll at a trainee rate who is not registered and participating in a training plan approved by the Employment and Training Administration shall be paid not less than the applicable wage rate on the wage determination for the classification of work actually performed. In addition, any trainee performing work on the job site in excess of the ratio permitted under the registered program shall be paid not less than the applicable wage rate on the wage determination for the work actually performed.

In the event the Employment and Training Administration withdraws approval of a training program, the contractor will no longer be permitted to utilize trainees at less than the applicable predetermined rate for the work performed until an acceptable program is approved.

c. Equal employment opportunity. The utilization of apprentices, trainees and journeymen under this part shall be in conformity with the equal employment opportunity requirements of Executive Order 11246, as amended, and 29 CFR part 30.

d. Apprentices and Trainees (programs of the U.S. DOT).

Apprentices and trainees working under apprenticeship and skill training programs which have been certified by the Secretary of Transportation as promoting EEO in connection with Federal-aid highway construction programs are not subject to the requirements of paragraph 4 of this Section IV. The straight time hourly wage rates for apprentices and trainees under such programs will be established by the particular programs. The ratio of apprentices and trainees to journeymen shall not be greater than permitted by the terms of the particular program.

5. Compliance with Copeland Act requirements. The contractor shall comply with the requirements of 29 CFR part 3, which are incorporated by reference in this contract.

6. Subcontracts. The contractor or subcontractor shall insert Form FHWA-1273 in any subcontracts and also require the subcontractors to include Form FHWA-1273 in any lower tier subcontracts. The prime contractor shall be responsible for the compliance by any subcontractor or lower tier subcontractor with all the contract clauses in 29 CFR 5.5.

7. Contract termination: debarment. A breach of the contract clauses in 29 CFR 5.5 may be grounds for termination of the contract, and for debarment as a contractor and a subcontractor as provided in 29 CFR 5.12.

8. Compliance with Davis-Bacon and Related Act requirements. All rulings and interpretations of the Davis-Bacon and Related Acts contained in 29 CFR parts 1, 3, and 5 are herein incorporated by reference in this contract.

9. Disputes concerning labor standards. Disputes arising out of the labor standards provisions of this contract shall not be subject to the general disputes clause of this contract. Such disputes shall be resolved in accordance with the procedures of the Department of Labor set forth in 29 CFR parts 5, 6, and 7. Disputes within the meaning of this clause include disputes between the contractor (or any of its subcontractors) and the contracting agency, the U.S. Department of Labor, or the employees or their representatives.

10. Certification of eligibility.

a. By entering into this contract, the contractor certifies that neither it (nor he or she) nor any person or firm who has an interest in the contractor's firm is a person or firm ineligible to be awarded Government contracts by virtue of section 3(a) of the Davis-Bacon Act or 29 CFR 5.12(a)(1).

b. No part of this contract shall be subcontracted to any person or firm ineligible for award of a Government contract by virtue of section 3(a) of the Davis-Bacon Act or 29 CFR 5.12(a)(1).

c. The penalty for making false statements is prescribed in the U.S. Criminal Code, 18 U.S.C. 1001.

V. CONTRACT WORK HOURS AND SAFETY STANDARDS ACT

The following clauses apply to any Federal-aid construction contract in an amount in excess of \$100,000 and subject to the overtime provisions of the Contract Work Hours and Safety Standards Act. These clauses shall be inserted in addition to the clauses required by 29 CFR 5.5(a) or 29 CFR 4.6. As used in this paragraph, the terms laborers and mechanics include watchmen and guards.

1. Overtime requirements. No contractor or subcontractor contracting for any part of the contract work which may require or involve the employment of laborers or mechanics shall require or permit any such laborer or mechanic in any workweek in which he or she is employed on such work to work in excess of forty hours in such workweek unless such laborer or mechanic receives compensation at a rate not less than one and one-half times the basic rate of pay for all hours worked in excess of forty hours in such workweek.

2. Violation; liability for unpaid wages; liquidated damages. In the event of any violation of the clause set forth in paragraph (1.) of this section, the contractor and any subcontractor responsible therefor shall be liable for the unpaid wages. In addition, such contractor and subcontractor shall be liable to the United States (in the case of work done under contract for the District of Columbia or a territory, to such District or to such territory), for liquidated damages. Such liquidated damages shall be computed with respect to each individual laborer or mechanic, including watchmen and guards, employed in violation of the clause set forth in paragraph (1.) of this section, in the sum of \$10 for each calendar day on which such individual was required or permitted to work in excess of the standard workweek of forty hours without payment of the overtime wages required by the clause set forth in paragraph (1.) of this section.

3. Withholding for unpaid wages and liquidated damages. The FHWA or the contracting agency shall upon its own action or upon written request of an authorized representative of the Department of Labor withhold or cause to be withheld, from any moneys payable on account of work performed by the contractor or subcontractor under any such contract or any other Federal contract with the same prime contractor, or any other federally-assisted contract subject to the Contract Work Hours and Safety Standards Act, which is held by the same prime contractor, such sums as may be determined to be necessary to satisfy any liabilities of such contractor or subcontractor for unpaid wages and liquidated damages as provided in the clause set forth in paragraph (2.) of this section.

4. Subcontracts. The contractor or subcontractor shall insert in any subcontracts the clauses set forth in paragraph (1.) through (4.) of this section and also a clause requiring the subcontractors to include these clauses in any lower tier subcontracts. The prime contractor shall be responsible for compliance by any subcontractor or lower tier subcontractor with the clauses set forth in paragraphs (1.) through (4.) of this section.

VI. SUBLETTING OR ASSIGNING THE CONTRACT

This provision is applicable to all Federal-aid construction contracts on the National Highway System.

1. The contractor shall perform with its own organization contract work amounting to not less than 30 percent (or a greater percentage if specified elsewhere in the contract) of the total original contract price, excluding any specialty items designated by the contracting agency. Specialty items may be performed by subcontract and the amount of any such specialty items performed may be deducted from the total original contract price before computing the amount of work required to be performed by the contractor's own organization (23 CFR 635.116).

a. The term "perform work with its own organization" refers to workers employed or leased by the prime contractor, and equipment owned or rented by the prime contractor, with or without operators. Such term does not include employees or equipment of a subcontractor or lower tier subcontractor, agents of the prime contractor, or any other assignees. The term may include payments for the costs of hiring leased employees from an employee leasing firm meeting all relevant Federal and State regulatory requirements. Leased employees may only be included in this term if the prime contractor meets all of the following conditions:

(1) the prime contractor maintains control over the supervision of the day-to-day activities of the leased employees;

(2) the prime contractor remains responsible for the quality of the work of the leased employees;

(3) the prime contractor retains all power to accept or exclude individual employees from work on the project; and

(4) the prime contractor remains ultimately responsible for the payment of predetermined minimum wages, the submission of payrolls, statements of compliance and all other Federal regulatory requirements.

b. "Specialty Items" shall be construed to be limited to work that requires highly specialized knowledge, abilities, or equipment not ordinarily available in the type of contracting organizations qualified and expected to bid or propose on the contract as a whole and in general are to be limited to minor components of the overall contract.

2. The contract amount upon which the requirements set forth in paragraph (1) of Section VI is computed includes the cost of material and manufactured products which are to be purchased or produced by the contractor under the contract provisions.

3. The contractor shall furnish (a) a competent superintendent or supervisor who is employed by the firm, has full authority to direct performance of the work in accordance with the contract requirements, and is in charge of all construction operations (regardless of who performs the work) and (b) such other of its own organizational resources (supervision, management, and engineering services) as the contracting officer determines is necessary to assure the performance of the contract.

4. No portion of the contract shall be sublet, assigned or otherwise disposed of except with the written consent of the contracting officer, or authorized representative, and such consent when given shall not be construed to relieve the contractor of any responsibility for the fulfillment of the contract. Written consent will be given only after the contracting agency has assured that each subcontract is

evidenced in writing and that it contains all pertinent provisions and requirements of the prime contract.

5. The 30% self-performance requirement of paragraph (1) is not applicable to design-build contracts; however, contracting agencies may establish their own self-performance requirements.

VII. SAFETY: ACCIDENT PREVENTION

This provision is applicable to all Federal-aid construction contracts and to all related subcontracts.

1. In the performance of this contract the contractor shall comply with all applicable Federal, State, and local laws governing safety, health, and sanitation (23 CFR 635). The contractor shall provide all safeguards, safety devices and protective equipment and take any other needed actions as it determines, or as the contracting officer may determine, to be reasonably necessary to protect the life and health of employees on the job and the safety of the public and to protect property in connection with the performance of the work covered by the contract.

2. It is a condition of this contract, and shall be made a condition of each subcontract, which the contractor enters into pursuant to this contract, that the contractor and any subcontractor shall not permit any employee, in performance of the contract, to work in surroundings or under conditions which are unsanitary, hazardous or dangerous to his/her health or safety, as determined under construction safety and health standards (29 CFR 1926) promulgated by the Secretary of Labor, in accordance with Section 107 of the Contract Work Hours and Safety Standards Act (40 U.S.C. 3704).

3. Pursuant to 29 CFR 1926.3, it is a condition of this contract that the Secretary of Labor or authorized representative thereof, shall have right of entry to any site of contract performance to inspect or investigate the matter of compliance with the construction safety and health standards and to carry out the duties of the Secretary under Section 107 of the Contract Work Hours and Safety Standards Act (40 U.S.C.3704).

VIII. FALSE STATEMENTS CONCERNING HIGHWAY PROJECTS

This provision is applicable to all Federal-aid construction contracts and to all related subcontracts.

In order to assure high quality and durable construction in conformity with approved plans and specifications and a high degree of reliability on statements and representations made by engineers, contractors, suppliers, and workers on Federal-aid highway projects, it is essential that all persons concerned with the project perform their functions as carefully, thoroughly, and honestly as possible. Willful falsification, distortion, or misrepresentation with respect to any facts related to the project is a violation of Federal law. To prevent any misunderstanding regarding the seriousness of these and similar acts, Form FHWA-1022 shall be posted on each Federal-aid highway project (23 CFR 635) in one or more places where it is readily available to all persons concerned with the project:

18 U.S.C. 1020 reads as follows:

"Whoever, being an officer, agent, or employee of the United States, or of any State or Territory, or whoever, whether a person, association, firm, or corporation, knowingly makes any false statement, false representation, or false report as to the character, quality, quantity, or cost of the material used or to be used, or the quantity or quality of the work performed or to be performed, or the cost thereof in connection with the submission of plans, maps, specifications, contracts, or costs of construction on any highway or related project submitted for approval to the Secretary of Transportation; or

Whoever knowingly makes any false statement, false representation, false report or false claim with respect to the character, quality, quantity, or cost of any work performed or to be performed, or materials furnished or to be furnished, in connection with the construction of any highway or related project approved by the Secretary of Transportation; or

Whoever knowingly makes any false statement or false representation as to material fact in any statement, certificate, or report submitted pursuant to provisions of the Federal-aid Roads Act approved July 1, 1916, (39 Stat. 355), as amended and supplemented;

Shall be fined under this title or imprisoned not more than 5 years or both."

IX. IMPLEMENTATION OF CLEAN AIR ACT AND FEDERAL WATER POLLUTION CONTROL ACT

This provision is applicable to all Federal-aid construction contracts and to all related subcontracts.

By submission of this bid/proposal or the execution of this contract, or subcontract, as appropriate, the bidder, proposer, Federal-aid construction contractor, or subcontractor, as appropriate, will be deemed to have stipulated as follows:

1. That any person who is or will be utilized in the performance of this contract is not prohibited from receiving an award due to a violation of Section 508 of the Clean Water Act or Section 306 of the Clean Air Act.

2. That the contractor agrees to include or cause to be included the requirements of paragraph (1) of this Section X in every subcontract, and further agrees to take such action as the contracting agency may direct as a means of enforcing such requirements.

X. CERTIFICATION REGARDING DEBARMENT, SUSPENSION, INELIGIBILITY AND VOLUNTARY EXCLUSION

This provision is applicable to all Federal-aid construction contracts, design-build contracts, subcontracts, lower-tier subcontracts, purchase orders, lease agreements, consultant contracts or any other covered transaction requiring FHWA approval or that is estimated to cost \$25,000 or more – as defined in 2 CFR Parts 180 and 1200.

1. Instructions for Certification – First Tier Participants:

a. By signing and submitting this proposal, the prospective first tier participant is providing the certification set out below.

b. The inability of a person to provide the certification set out below will not necessarily result in denial of participation in this

covered transaction. The prospective first tier participant shall submit an explanation of why it cannot provide the certification set out below. The certification or explanation will be considered in connection with the department or agency's determination whether to enter into this transaction. However, failure of the prospective first tier participant to furnish a certification or an explanation shall disqualify such a person from participation in this transaction.

c. The certification in this clause is a material representation of fact upon which reliance was placed when the contracting agency determined to enter into this transaction. If it is later determined that the prospective participant knowingly rendered an erroneous certification, in addition to other remedies available to the Federal Government, the contracting agency may terminate this transaction for cause of default.

d. The prospective first tier participant shall provide immediate written notice to the contracting agency to whom this proposal is submitted if any time the prospective first tier participant learns that its certification was erroneous when submitted or has become erroneous by reason of changed circumstances.

e. The terms "covered transaction," "debarred," "suspended," "ineligible," "participant," "person," "principal," and "voluntarily excluded," as used in this clause, are defined in 2 CFR Parts 180 and 1200. "First Tier Covered Transactions" refers to any covered transaction between a grantee or subgrantee of Federal funds and a participant (such as the prime or general contract). "Lower Tier Covered Transactions" refers to any covered transaction under a First Tier Covered Transaction (such as subcontracts). "First Tier Participant" refers to the participant who has entered into a covered transaction with a grantee or subgrantee of Federal funds (such as the prime or general contractor). "Lower Tier Participant" refers any participant who has entered into a covered transaction with a First Tier Participant or other Lower Tier Participants (such as subcontractors and suppliers).

f. The prospective first tier participant agrees by submitting this proposal that, should the proposed covered transaction be entered into, it shall not knowingly enter into any lower tier covered transaction with a person who is debarred, suspended, declared ineligible, or voluntarily excluded from participation in this covered transaction, unless authorized by the department or agency entering into this transaction.

g. The prospective first tier participant further agrees by submitting this proposal that it will include the clause titled "Certification Regarding Debarment, Suspension, Ineligibility and Voluntary Exclusion-Lower Tier Covered Transactions," provided by the department or contracting agency, entering into this covered transaction, without modification, in all lower tier covered transactions and in all solicitations for lower tier covered transactions exceeding the \$25,000 threshold.

h. A participant in a covered transaction may rely upon a certification of a prospective participant in a lower tier covered transaction that is not debarred, suspended, ineligible, or voluntarily excluded from the covered transaction, unless it knows that the certification is erroneous. A participant is responsible for ensuring that its principals are not suspended, debarred, or otherwise ineligible to participate in covered transactions. To verify the eligibility of its principals, as well as the eligibility of any lower tier prospective participants, each participant may, but is not required to, check the Excluded Parties List System website (<https://www.epls.gov/>), which is compiled by the General Services Administration.

i. Nothing contained in the foregoing shall be construed to require the establishment of a system of records in order to render in good faith the certification required by this clause. The knowledge and information of the prospective participant is not required to exceed that which is normally possessed by a prudent person in the ordinary course of business dealings.

j. Except for transactions authorized under paragraph (f) of these instructions, if a participant in a covered transaction knowingly enters into a lower tier covered transaction with a person who is suspended, debarred, ineligible, or voluntarily excluded from participation in this transaction, in addition to other remedies available to the Federal Government, the department or agency may terminate this transaction for cause or default.

* * * * *

2. Certification Regarding Debarment, Suspension, Ineligibility and Voluntary Exclusion – First Tier Participants:

a. The prospective first tier participant certifies to the best of its knowledge and belief, that it and its principals:

(1) Are not presently debarred, suspended, proposed for debarment, declared ineligible, or voluntarily excluded from participating in covered transactions by any Federal department or agency;

(2) Have not within a three-year period preceding this proposal been convicted of or had a civil judgment rendered against them for commission of fraud or a criminal offense in connection with obtaining, attempting to obtain, or performing a public (Federal, State or local) transaction or contract under a public transaction; violation of Federal or State antitrust statutes or commission of embezzlement, theft, forgery, bribery, falsification or destruction of records, making false statements, or receiving stolen property;

(3) Are not presently indicted for or otherwise criminally or civilly charged by a governmental entity (Federal, State or local) with commission of any of the offenses enumerated in paragraph (a)(2) of this certification; and

(4) Have not within a three-year period preceding this application/proposal had one or more public transactions (Federal, State or local) terminated for cause or default.

b. Where the prospective participant is unable to certify to any of the statements in this certification, such prospective participant shall attach an explanation to this proposal.

2. Instructions for Certification - Lower Tier Participants:

(Applicable to all subcontracts, purchase orders and other lower tier transactions requiring prior FHWA approval or estimated to cost \$25,000 or more - 2 CFR Parts 180 and 1200)

a. By signing and submitting this proposal, the prospective lower tier is providing the certification set out below.

b. The certification in this clause is a material representation of fact upon which reliance was placed when this transaction was entered into. If it is later determined that the prospective lower tier participant knowingly rendered an erroneous certification, in addition to other remedies available to the Federal Government, the department, or agency with which

this transaction originated may pursue available remedies, including suspension and/or debarment.

c. The prospective lower tier participant shall provide immediate written notice to the person to which this proposal is submitted if at any time the prospective lower tier participant learns that its certification was erroneous by reason of changed circumstances.

d. The terms "covered transaction," "debarred," "suspended," "ineligible," "participant," "person," "principal," and "voluntarily excluded," as used in this clause, are defined in 2 CFR Parts 180 and 1200. You may contact the person to which this proposal is submitted for assistance in obtaining a copy of those regulations. "First Tier Covered Transactions" refers to any covered transaction between a grantee or subgrantee of Federal funds and a participant (such as the prime or general contract). "Lower Tier Covered Transactions" refers to any covered transaction under a First Tier Covered Transaction (such as subcontracts). "First Tier Participant" refers to the participant who has entered into a covered transaction with a grantee or subgrantee of Federal funds (such as the prime or general contractor). "Lower Tier Participant" refers any participant who has entered into a covered transaction with a First Tier Participant or other Lower Tier Participants (such as subcontractors and suppliers).

e. The prospective lower tier participant agrees by submitting this proposal that, should the proposed covered transaction be entered into, it shall not knowingly enter into any lower tier covered transaction with a person who is debarred, suspended, declared ineligible, or voluntarily excluded from participation in this covered transaction, unless authorized by the department or agency with which this transaction originated.

f. The prospective lower tier participant further agrees by submitting this proposal that it will include this clause titled "Certification Regarding Debarment, Suspension, Ineligibility and Voluntary Exclusion-Lower Tier Covered Transaction," without modification, in all lower tier covered transactions and in all solicitations for lower tier covered transactions exceeding the \$25,000 threshold.

g. A participant in a covered transaction may rely upon a certification of a prospective participant in a lower tier covered transaction that is not debarred, suspended, ineligible, or voluntarily excluded from the covered transaction, unless it knows that the certification is erroneous. A participant is responsible for ensuring that its principals are not suspended, debarred, or otherwise ineligible to participate in covered transactions. To verify the eligibility of its principals, as well as the eligibility of any lower tier prospective participants, each participant may, but is not required to, check the Excluded Parties List System website (<https://www.epls.gov/>), which is compiled by the General Services Administration.

h. Nothing contained in the foregoing shall be construed to require establishment of a system of records in order to render in good faith the certification required by this clause. The knowledge and information of participant is not required to exceed that which is normally possessed by a prudent person in the ordinary course of business dealings.

i. Except for transactions authorized under paragraph e of these instructions, if a participant in a covered transaction knowingly enters into a lower tier covered transaction with a person who is suspended, debarred, ineligible, or voluntarily excluded from participation in this transaction, in addition to other remedies available to the Federal Government, the

department or agency with which this transaction originated may pursue available remedies, including suspension and/or debarment.

* * * * *

Certification Regarding Debarment, Suspension, Ineligibility and Voluntary Exclusion--Lower Tier Participants:

1. The prospective lower tier participant certifies, by submission of this proposal, that neither it nor its principals is presently debarred, suspended, proposed for debarment, declared ineligible, or voluntarily excluded from participating in covered transactions by any Federal department or agency.

2. Where the prospective lower tier participant is unable to certify to any of the statements in this certification, such prospective participant shall attach an explanation to this proposal.

* * * * *

XI. CERTIFICATION REGARDING USE OF CONTRACT FUNDS FOR LOBBYING

This provision is applicable to all Federal-aid construction contracts and to all related subcontracts which exceed \$100,000 (49 CFR 20).

1. The prospective participant certifies, by signing and submitting this bid or proposal, to the best of his or her knowledge and belief, that:

a. No Federal appropriated funds have been paid or will be paid, by or on behalf of the undersigned, to any person for influencing or attempting to influence an officer or employee of any Federal agency, a Member of Congress, an officer or employee of Congress, or an employee of a Member of Congress in connection with the awarding of any Federal contract, the making of any Federal grant, the making of any Federal loan, the entering into of any cooperative agreement, and the extension, continuation, renewal, amendment, or modification of any Federal contract, grant, loan, or cooperative agreement.

b. If any funds other than Federal appropriated funds have been paid or will be paid to any person for influencing or attempting to influence an officer or employee of any Federal agency, a Member of Congress, an officer or employee of Congress, or an employee of a Member of Congress in connection with this Federal contract, grant, loan, or cooperative agreement, the undersigned shall complete and submit Standard Form-LLL, "Disclosure Form to Report Lobbying," in accordance with its instructions.

2. This certification is a material representation of fact upon which reliance was placed when this transaction was made or entered into. Submission of this certification is a prerequisite for making or entering into this transaction imposed by 31 U.S.C. 1352. Any person who fails to file the required certification shall be subject to a civil penalty of not less than \$10,000 and not more than \$100,000 for each such failure.

3. The prospective participant also agrees by submitting its bid or proposal that the participant shall require that the language of this certification be included in all lower tier subcontracts, which exceed \$100,000 and that all such recipients shall certify and disclose accordingly.

**ATTACHMENT A - EMPLOYMENT AND MATERIALS
PREFERENCE FOR APPALACHIAN DEVELOPMENT
HIGHWAY SYSTEM OR APPALACHIAN LOCAL ACCESS
ROAD CONTRACTS**

This provision is applicable to all Federal-aid projects funded under the Appalachian Regional Development Act of 1965.

1. During the performance of this contract, the contractor undertaking to do work which is, or reasonably may be, done as on-site work, shall give preference to qualified persons who regularly reside in the labor area as designated by the DOL wherein the contract work is situated, or the subregion, or the Appalachian counties of the State wherein the contract work is situated, except:

a. To the extent that qualified persons regularly residing in the area are not available.

b. For the reasonable needs of the contractor to employ supervisory or specially experienced personnel necessary to assure an efficient execution of the contract work.

c. For the obligation of the contractor to offer employment to present or former employees as the result of a lawful collective bargaining contract, provided that the number of nonresident persons employed under this subparagraph (1c) shall not exceed 20 percent of the total number of employees employed by the contractor on the contract work, except as provided in subparagraph (4) below.

2. The contractor shall place a job order with the State Employment Service indicating (a) the classifications of the laborers, mechanics and other employees required to perform the contract work, (b) the number of employees required in each classification, (c) the date on which the participant estimates such employees will be required, and (d) any other pertinent information required by the State Employment Service to complete the job order form. The job order may be placed with the State Employment Service in writing or by telephone. If during the course of the contract work, the information submitted by the contractor in the original job order is substantially modified, the participant shall promptly notify the State Employment Service.

3. The contractor shall give full consideration to all qualified job applicants referred to him by the State Employment Service. The contractor is not required to grant employment to any job applicants who, in his opinion, are not qualified to perform the classification of work required.

4. If, within one week following the placing of a job order by the contractor with the State Employment Service, the State Employment Service is unable to refer any qualified job applicants to the contractor, or less than the number requested, the State Employment Service will forward a certificate to the contractor indicating the unavailability of applicants. Such certificate shall be made a part of the contractor's permanent project records. Upon receipt of this certificate, the contractor may employ persons who do not normally reside in the labor area to fill positions covered by the certificate, notwithstanding the provisions of subparagraph (1c) above.

5. The provisions of 23 CFR 633.207(e) allow the contracting agency to provide a contractual preference for the use of mineral resource materials native to the Appalachian region.

6. The contractor shall include the provisions of Sections 1 through 4 of this Attachment A in every subcontract for work which is, or reasonably may be, done as on-site work.

**KENTUCKY TRANSPORTATION CABINET
DEPARTMENT OF HIGHWAYS**

**EMPLOYMENT REQUIREMENTS
RELATING TO
NONDISCRIMINATION OF EMPLOYEES
(APPLICABLE TO FEDERAL-AID SYSTEM CONTRACTS)**

**AN ACT OF THE KENTUCKY GENERAL ASSEMBLY
TO PREVENT DISCRIMINATION IN EMPLOYMENT**

**KRS CHAPTER 344
EFFECTIVE JUNE 16, 1972**

The contract on this project, in accordance with KRS Chapter 344, provides that during the performance of this contract, the contractor agrees as follows:

1. The contractor shall not fail or refuse to hire, or shall not discharge any individual, or otherwise discriminate against an individual with respect to his compensation, terms, conditions, or privileges of employment, because of such individual's race, color, religion, national origin, sex, disability or age (forty and above); or limit, segregate, or classify his employees in any way which would deprive or tend to deprive an individual of employment opportunities or otherwise adversely affect his status as an employee, because of such individual's race, color, religion, national origin, sex, disability or age forty (40) and over. The contractor agrees to post in conspicuous places, available to employees and applicants for employment, notices to be provided setting forth the provisions of this nondiscrimination clause.

2. The contractor shall not print or publish or cause to be printed or published a notice or advertisement relating to employment by such an employer or membership in or any classification or referral for employment by the employment agency, indicating any preference, limitation, specification, or discrimination, based on race, color, religion, national origin, sex, or age forty (40) and over, or because the person is a qualified individual with a disability, except that such a notice or advertisement may indicate a preference, limitation, or specification based on religion, national origin, sex, or age forty (40) and over, or because the person is a qualified individual with a disability, when religion, national origin, sex, or age forty (40) and over, or because the person is a qualified individual with a disability, is a bona fide occupational qualification for employment.

3. If the contractor is in control of apprenticeship or other training or retraining, including on-the-job training programs, he shall not discriminate against an individual because of his race, color, religion, national origin, sex, disability or age forty (40) and over, in admission to, or employment in any program established to provide apprenticeship or other training.

4. The contractor will send to each labor union or representative of workers with which he has a collective bargaining agreement or other contract or understanding, a notice to be provided advising the said labor union or workers' representative of the contractor's commitments under this section, and shall post copies of the notice in conspicuous places available to employees and applicants for employment. The contractor will take such action with respect to any subcontract or purchase order as the administering agency may direct as a means of enforcing such provisions, including sanctions for non-compliance.

Revised: January 25, 2017

Standard Title VI/Non-Discrimination Assurances

During the performance of this contract, the contractor, for itself, its assignees, and successors in interest (hereinafter referred to as the “contractor”) agrees as follows:

1. **Compliance with Regulations:** The contractor (hereinafter includes consultants) will comply with the Acts and the Regulations relative to Non-discrimination in Federally-assisted programs of the U.S. Department of Transportation, **Federal Highway Administration**, as they may be amended from time to time, which are herein incorporated by reference and made a part of this contract.
2. **Non-discrimination:** The contractor, with regard to the work performed by it during the contract, will not discriminate on the grounds of race, color, or national origin in the selection and retention of subcontractors, including procurements of materials and leases of equipment. The contractor will not participate directly or indirectly in the discrimination prohibited by the Acts and the Regulations, including employment practices when the contract covers any activity, project, or program set forth in Appendix B of 49 CFR Part 21.
3. **Solicitations for Subcontracts, Including Procurements of Materials and Equipment:** In all solicitations, either by competitive bidding, or negotiation made by the contractor for work to be performed under a subcontract, including procurements of materials, or leases of equipment, each potential subcontractor or supplier will be notified by the contractor of the contractor’s obligations under this contract and the Acts and the Regulations relative to Non-discrimination on the grounds of race, color, or national origin.
4. **Information and Reports:** The contractor will provide all information and reports required by the Acts, the Regulations, and directives issued pursuant thereto and will permit access to its books, records, accounts, other sources of information, and its facilities as may be determined by the Recipient or the **Federal Highway Administration** to be pertinent to ascertain compliance with such Acts, Regulations, and instructions. Where any information required of a contractor is in the exclusive possession of another who fails or refuses to furnish the information, the contractor will so certify to the Recipient or the **Federal Highway Administration**, as appropriate, and will set forth what efforts it has made to obtain the information.
5. **Sanctions for Noncompliance:** In the event of a contractor’s noncompliance with the Non-discrimination provisions of this contract, the Recipient will impose such contract sanctions as it or the **Federal Highway Administration** may determine to be appropriate, including, but not limited to:
 - a. withholding payments to the contractor under the contract until the contractor complies; and/or
 - b. cancelling, terminating, or suspending a contract, in whole or in part.
6. **Incorporation of Provisions:** The contractor will include the provisions of paragraphs one through six in every subcontract, including procurements of materials and leases of equipment, unless exempt by the Acts, the Regulations and directives issued pursuant thereto. The contractor will take action with respect to any subcontract or procurement as the Recipient or the **Federal Highway Administration** may direct as a means of enforcing such provisions including sanctions for noncompliance. Provided, that if the contractor becomes involved in, or is threatened with litigation by a subcontractor, or supplier because of such direction, the contractor may request the Recipient to enter into any litigation to protect the interests of the Recipient. In addition, the contractor may request the United States to enter into the litigation to protect the interests of the United States.

Standard Title VI/Non-Discrimination Statutes and Authorities

During the performance of this contract, the contractor, for itself, its assignees, and successors in interest (hereinafter referred to as the “contractor”) agrees to comply with the following non-discrimination statutes and authorities; including but not limited to:

- Title VI of the Civil Rights Act of 1964 (42 U.S.C. § 2000d *et seq.*, 78 stat. 252), (prohibits discrimination on the basis of race, color, national origin); and 49 CFR Part 21;
- The Uniform Relocation Assistance and Real Property Acquisition Policies Act of 1970, (42 U.S.C. § 4601), (prohibits unfair treatment of persons displaced or whose property has been acquired because of Federal or Federal-aid programs and projects);
- Federal-Aid Highway Act of 1973, (23 U.S.C. § 324 *et seq.*), (prohibits discrimination on the basis of sex);
- Section 504 of the Rehabilitation Act of 1973, (29 U.S.C. § 794 *et seq.*), as amended, (prohibits discrimination on the basis of disability); and 49 CFR Part 27;
- The Age Discrimination Act of 1975, as amended, (42 U.S.C. § 6101 *et seq.*), (prohibits discrimination on the basis of age);
- Airport and Airway Improvement Act of 1982, (49 USC § 471, Section 47123), as amended, (prohibits discrimination based on race, creed, color, national origin, or sex);
- The Civil Rights Restoration Act of 1987, (PL 100-209), (Broadened the scope, coverage and applicability of Title VI of the Civil Rights Act of 1964, The Age Discrimination Act of 1975 and Section 504 of the Rehabilitation Act of 1973, by expanding the definition of the terms “programs or activities” to include all of the programs or activities of the Federal-aid recipients, sub-recipients and contractors, whether such programs or activities are Federally funded or not);
- Titles II and III of the Americans with Disabilities Act, which prohibit discrimination on the basis of disability in the operation of public entities, public and private transportation systems, places of public accommodation, and certain testing entities (42 U.S.C. §§ 12131 -- 12189) as implemented by Department of Transportation regulations at 49 C.F.R. parts 37 and 38;
- The Federal Aviation Administration’s Non-discrimination statute (49 U.S.C. § 47123) (prohibits discrimination on the basis of race, color, national origin, and sex);
- Executive Order 12898, Federal Actions to Address Environmental Justice in Minority Populations and Low-Income Populations, which ensures non-discrimination against minority populations by discouraging programs, policies, and activities with disproportionately high and adverse human health or environmental effects on minority and low-income populations;
- Executive Order 13166, Improving Access to Services for Persons with Limited English Proficiency, and resulting agency guidance, national origin discrimination includes discrimination because of limited English proficiency (LEP). To ensure compliance with Title VI, you must take reasonable steps to ensure that LEP persons have meaningful access to your programs (70 Fed. Reg. at 74087 to 74100);
- Title IX of the Education Amendments of 1972, as amended, which prohibits you from discriminating because of sex in education programs or activities (20 U.S.C. 1681 *et seq.*)

EXECUTIVE BRANCH CODE OF ETHICS

In the 1992 regular legislative session, the General Assembly passed and Governor Brereton Jones signed Senate Bill 63 (codified as KRS 11A), the Executive Branch Code of Ethics, which states, in part:

KRS 11A.040 (7) provides:

No present or former public servant shall, within six (6) months following termination of his office or employment, accept employment, compensation, or other economic benefit from any person or business that contracts or does business with, or is regulated by, the state in matters in which he was directly involved during the last thirty-six (36) months of his tenure. This provision shall not prohibit an individual from returning to the same business, firm, occupation, or profession in which he was involved prior to taking office or beginning his term of employment, or for which he received, prior to his state employment, a professional degree or license, provided that, for a period of six (6) months, he personally refrains from working on any matter in which he was directly involved during the last thirty-six (36) months of his tenure in state government. This subsection shall not prohibit the performance of ministerial functions, including but not limited to filing tax returns, filing applications for permits or licenses, or filing incorporation papers, nor shall it prohibit the former officer or public servant from receiving public funds disbursed through entitlement programs.

KRS 11A.040 (9) states:

A former public servant shall not represent a person or business before a state agency in a matter in which the former public servant was directly involved during the last thirty-six (36) months of his tenure, for a period of one (1) year after the latter of:

- a) The date of leaving office or termination of employment; or
- b) The date the term of office expires to which the public servant was elected.

This law is intended to promote public confidence in the integrity of state government and to declare as public policy the idea that state employees should view their work as a public trust and not as a way to obtain private benefits.

If you have worked for the executive branch of state government within the past six months, you may be subject to the law's prohibitions. The law's applicability may be different if you hold elected office or are contemplating representation of another before a state agency.

Also, if you are affiliated with a firm which does business with the state and which employs former state executive-branch employees, you should be aware that the law may apply to them.

In case of doubt, the law permits you to request an advisory opinion from the Executive Branch Ethics Commission, 3 Fountain Place, Frankfort, Kentucky 40601; telephone (502) 564-7954.

Revised: January 27, 2017

"General Decision Number: KY20220040 02/25/2022

Superseded General Decision Number: KY20210040

State: Kentucky

Construction Type: Highway

Counties: Allen, Ballard, Butler, Caldwell, Calloway, Carlisle, Christian, Crittenden, Daviess, Edmonson, Fulton, Graves, Hancock, Henderson, Hickman, Hopkins, Livingston, Logan, Lyon, Marshall, McCracken, McLean, Muhlenberg, Ohio, Simpson, Todd, Trigg, Union, Warren and Webster Counties in Kentucky.

HIGHWAY CONSTRUCTION PROJECTS (excluding tunnels, building structures in rest area projects & railroad construction; bascule, suspension & spandrel arch bridges designed for commercial navigation, bridges involving marine construction; and other major bridges).

Note: Contracts subject to the Davis-Bacon Act are generally required to pay at least the applicable minimum wage rate required under Executive Order 14026 or Executive Order 13658. Please note that these Executive Orders apply to covered contracts entered into by the federal government that are subject to the Davis-Bacon Act itself, but do not apply to contracts subject only to the Davis-Bacon Related Acts, including those set forth at 29 CFR 5.1(a)(2)-(60).

<p>If the contract is entered into on or after January 30, 2022, or the contract is renewed or extended (e.g., an option is exercised) on or after January 30, 2022:</p>	<ul style="list-style-type: none"> . Executive Order 14026 generally applies to the contract. . The contractor must pay all covered workers at least \$15.00 per hour (or the applicable wage rate listed on this wage determination, if it is higher) for all hours spent performing on the contract in 2022.
<p>If the contract was awarded on or between January 1, 2015 and January 29, 2022, and the contract is not renewed or extended on or after January 30, 2022:</p>	<ul style="list-style-type: none"> . Executive Order 13658 generally applies to the contract. . The contractor must pay all covered workers at least \$11.25 per hour (or the applicable wage rate listed on this wage determination, if it is higher) for all hours spent performing on that contract in 2022.

The applicable Executive Order minimum wage rate will be adjusted annually. If this contract is covered by one of the Executive Orders and a classification considered necessary for performance of work on the contract does not appear on this wage determination, the contractor must still submit a conformance request.

Additional information on contractor requirements and worker protections under the Executive Orders is available at <https://www.dol.gov/agencies/whd/government-contracts>.

Modification Number	Publication Date
0	01/07/2022
1	01/14/2022
2	02/11/2022
3	02/18/2022
4	02/25/2022

BRIN0004-002 06/01/2021

BALLARD, BUTLER, CALDWELL, CARLISLE, CRITTENDEN, DAVIESS, EDMONSON, FULTON, GRAVES, HANCOCK, HENDERSON, HICKMAN, HOPKINS, LIVINGSTON, LYON, MARSHALL, MCCRACKEN, MCLEAN, MUHLENBERG, OHIO, UNION, and WEBSTER COUNTIES

	Rates	Fringes
BRICKLAYER		
Ballard, Caldwell, Carlisle, Crittenden, Fulton, Graves, Hickman, Livingston, Lyon, Marshall, and McCracken Counties.....	\$ 30.50	15.16
Butler, Edmonson, Hopkins, Muhlenberg, and Ohio Counties.....	\$ 26.80	12.38
Daviess, Hancock, Henderson, McLean, Union, and Webster Counties.....	\$ 29.57	14.75

 BRTN0004-005 06/01/2021

ALLEN, CALLOWAY, CHRISTIAN, LOGAN, SIMPSON, TODD, TRIGG, and WARREN COUNTIES

	Rates	Fringes
BRICKLAYER.....	\$ 29.75	14.75

 CARP0357-002 04/01/2020

	Rates	Fringes
CARPENTER.....	\$ 29.81	19.92
DIVER.....	\$ 45.09	19.92
PILEDRIVERMAN.....	\$ 30.06	19.92

 ELEC0369-006 05/31/2021

BUTLER, EDMONSON, LOGAN, TODD & WARREN COUNTIES:

	Rates	Fringes
ELECTRICIAN.....	\$ 33.85	18.72

 ELEC0429-001 01/01/2020

ALLEN & SIMPSON COUNTIES:

	Rates	Fringes
ELECTRICIAN.....	\$ 27.72	13.48

ELEC0816-002 06/01/2021		

BALLARD, CALDWELL, CALLOWAY, CARLISLE, CHRISTIAN, CRITTENDEN,
FULTON (Except a 5 mile radius of City Hall in Fulton), GRAVES,
HICKMAN, LIVINGSTON, LYON, MARSHALL, MCCRACKEN & TRIGG COUNTIES:

	Rates	Fringes
ELECTRICIAN.....	\$ 34.48	26.5%+7.25

Cable spicers receive \$.25 per hour additional.		

ELEC1701-003 06/01/2021		

DAVIESS, HANCOCK, HENDERSON, HOPKINS, MCLEAN, MUHLENBERG, OHIO,
UNION & WEBSTER COUNTIES:

	Rates	Fringes
ELECTRICIAN.....	\$ 33.30	28.8%+\$7.25

Cable spicers receive \$.25 per hour additional.		

ELEC1925-002 01/01/2022		

FULTON COUNTY (Up to a 5 mile radius of City Hall in Fulton):

	Rates	Fringes
CABLE SPLICER.....	\$ 26.85	14.81
ELECTRICIAN.....	\$ 26.35	14.79

ENGI0181-017 07/01/2021		

	Rates	Fringes
POWER EQUIPMENT OPERATOR		
GROUP 1.....	\$ 34.80	17.85
GROUP 2.....	\$ 31.94	17.85
GROUP 3.....	\$ 32.39	17.85
GROUP 4.....	\$ 31.62	17.85

OPERATING ENGINEER CLASSIFICATIONS

GROUP 1 - A-Frame Winch Truck; Auto Patrol; Backfiller;
Batcher Plant; Bituminous Paver; Bituminous Transfer
Machine; Boom Cat; Bulldozer; Mechanic; Cableway; Carry-All
Scoop; Carry Deck Crane; Central Compressor Plant; Cherry
Picker; Clamshell; Concrete Mixer (21 cu. ft. or Over);
Concrete Paver; Truck-Mounted Concrete Pump; Core Drill;
Crane; Crusher Plant; Derrick; Derrick Boat; Ditching &
Trenching Machine; Dragline; Dredge Operator; Dredge
Engineer; Elevating Grader & Loaders; Grade-All; Gurries;
Heavy Equipment Robotics Operator/Mechanic; High Lift;
Hoe-Type Machine; Hoist (Two or More Drums); Hoisting
Engine (Two or More Drums); Horizontal Directional Drill
Operator; Hydrocrane; Hyster; KeCal Loader; LeTourneau;

Locomotive; Mechanic; Mechanically Operated Laser Screed; Mechanic Welder; Mucking Machine; Motor Scraper; Orangepeel Bucket; Overhead Crane; Piledriver; Power Blade; Pumpcrete; Push Dozer; Rock Spreader, attached to equipment; Rotary Drill; Roller (Bituminous); Rough Terrain Crane; Scarifier; Scoopmobile; Shovel; Side Boom; Subgrader; Tailboom; Telescoping Type Forklift; Tow or Push Boat; Tower Crane (French, German & other types); Tractor Shovel; Truck Crane; Tunnel Mining Machines, including Moles, Shields or similar types of Tunnel Mining Equipment

GROUP 2 - Air Compressor (Over 900 cu. ft. per min.); Bituminous Mixer; Boom Type Tamping Machine; Bull Float; Concrete Mixer (Under 21 cu. ft.); Dredge Engineer; Electric Vibrator; Compactor/Self-Propelled Compactor; Elevator (One Drum or Buck Hoist); Elevator (When used to Hoist Building Material); Finish Machine; Firemen & Hoist (One Drum); Flexplane; Forklift (Regardless of Lift Height); Form Grader; Joint Sealing Machine; Outboard Motor Boat; Power Sweeper (Riding Type); Roller (Rock); Ross Carrier; Skid Mounted or Trailer Mounted Concrete Pump; Skid Steer Machine with all Attachments; Switchman or Brakeman; Throttle Valve Person; Tractair & Road Widening Trencher; Tractor (50 H.P. or Over); Truck Crane Oiler; Tugger; Welding Machine; Well Points;& Whirley Oiler

GROUP 3 -All Off Road Material Handling Equipment, including Articulating Dump Trucks; Greaser on Grease Facilities servicing Heavy Equipment

GROUP 4 - Bituminous Distributor; Burlap & Curing Machine; Cement Gun; Concrete Saw; Conveyor; Deckhand Oiler; Grout Pump; Hydraulic Post Driver; Hydro Seeder; Mud Jack; Oiler; Paving Joint Machine; Power Form Handling Equipment; Pump; Roller (Earth); Steerman; Tamping Machine; Tractor (Under 50 H.P.); & Vibrator

CRANES - with booms 150 ft. & Over (Including JIB), and where the length of the boom in combination with the length of the piling equals or exceeds 150 ft. - \$1.00 above Group 1 rate

EMPLOYEES ASSIGNED TO WORK BELOW GROUND LEVEL ARE TO BE PAID 10% ABOVE BASIC WAGE RATE. THIS DOES NOT APPLY TO OPEN CUT WORK.

IRON0070-005 06/01/2021

BUTLER COUNTY (Eastern eighth, including the Townships of Decker, Lee & Tilford);
EDMONSON COUNTY (Northern three-fourths, including the Townships of Asphalt, Bee Spring, Brownsville, Grassland, Huff, Kyrock, Lindseyville, Mammoth Cave, Ollie, Prosperity, Rhoda, Sunfish & Sweden)

Rates Fringes

IRONWORKER

Structural; Ornamental;
Reinforcing; Precast
Concrete Erectors.....\$ 31.09 23.75

IRON0103-004 08/01/2021

DAVIESS, HANCOCK, HENDERSON, HOPKINS, MCLEAN, OHIO, UNION & WEBSTER COUNTIES
 BUTLER COUNTY (Townships of Aberdeen, Bancock, Casey, Dexterville, Dunbar, Elfie, Gilstrap, Huntsville, Logansport, Monford, Morgantown, Provo, Rochester, South Hill & Welchs Creek);
 CALDWELL COUNTY (Northeastern third, including the Township of Creswell);
 CHRISTIAN COUNTY (Northern third, including the Townships of Apex, Crofton, Kelly, Mannington & Wynns);
 CRITTENDEN COUNTY (Northeastern half, including the Townships of Grove, Mattoon, Repton, Shady Grove & Tribune);
 MUHLENBERG COUNTY (Townships of Bavier, Beech Creek Junction, Benton, Brennen, Browder, Central City, Cleaton, Depoy, Drakesboro, Eunis, Graham, Hillside, Luzerne, Lynn City, Martwick, McNary, Millport, Moorman, Nelson, Paradise, Powderly, South Carrollton, Tarina & Weir)

	Rates	Fringes
Ironworkers:.....	\$ 30.00	25.29

IRON0492-003 05/01/2021		

ALLEN, LOGAN, SIMPSON, TODD & WARREN COUNTIES
 BUTLER COUNTY (Southern third, including the Townships of Boston, Berrys Lick, Dimple, Jetson, Quality, Sharer, Sugar Grove & Woodbury);
 CHRISTIAN COUNTY (Eastern two-thirds, including the Townships of Bennettstown, Casky, Herndon, Hopkinsville, Howell, Masonville, Pembroke & Thompsonville);
 EDMONSON COUNTY (Southern fourth, including the Townships of Chalybeate & Rocky Hill);
 MUHLENBERG COUNTY (Southern eighth, including the Townships of Dunnior, Penrod & Rosewood)

	Rates	Fringes
Ironworkers:.....	\$ 30.35	15.36

IRON0782-006 08/01/2021		

BALLARD, CALLOWAY, CARLISLE, FULTON, GRAVES, HICKMAN, LIVINGSTON, LYON, MARSHALL, MCCRACKEN & TRIGG COUNTIES
 CALDWELL COUNTY (Southwestern two-thirds, including the Townships of Cedar Bluff, Cider, Claxton, Cobb, Crowtown, Dulaney, Farmersville, Fredonia, McGowan, Otter Pond & Princeton);
 CHRISTIAN COUNTY (Western third, Excluding the Townships of Apex, Crofton, Kelly, Mannington, Wynns, Bennettstown, Casky, Herndon, Hopkinsville, Howell, Masonville, Pembroke & Thompsonville);
 CRITTENDEN COUNTY (Southwestern half, including the Townships of Crayne, Dycusburg, Frances, Marion, Mexico, Midway, Sheridan & Told)

	Rates	Fringes
Ironworkers:		
Projects with a total contract cost of		

\$20,000,000.00 or above.....\$ 30.83	25.52
All Other Work.....\$ 29.24	23.22

 LAB00189-005 07/01/2021

BALLARD, CALLOWAY, CARLISLE, FULTON, GRAVES, HICKMAN,
 LIVINGSTON, LYON, MARSHALL & MCCRACKEN COUNTIES

	Rates	Fringes
Laborers:		
GROUP 1.....\$ 23.51		16.22
GROUP 2.....\$ 23.76		16.22
GROUP 3.....\$ 23.81		16.22
GROUP 4.....\$ 24.41		16.22

LABORER CLASSIFICATIONS

GROUP 1 - Aging & Curing of Concrete; Asbestos Abatement Worker; Asphalt Plant; Asphalt; Batch Truck Dump; Carpenter Tender; Cement Mason Tender; Cleaning of Machines; Concrete; Demolition; Dredging; Environmental - Nuclear, Radiation, Toxic & Hazardous Waste - Level D; Flagperson; Grade Checker; Hand Digging & Hand Back Filling; Highway Marker Placer; Landscaping, Mesh Handler & Placer; Puddler; Railroad; Rip-rap & Grouter; Right-of-Way; Sign, Guard Rail & Fence Installer; Signal Person; Sound Barrier Installer; Storm & Sanitary Sewer; Swamper; Truck Spotter & Dumper; Wrecking of Concrete Forms; General Cleanup

GROUP 2 - Batter Board Man (Sanitary & Storm Sewer); Brickmason Tender; Mortar Mixer Operator; Scaffold Builder; Burner & Welder; Bushhammer; Chain Saw Operator; Concrete Saw Operator; Deckhand Scow Man; Dry Cement Handler; Environmental - Nuclear, Radiation, Toxic & Hazardous Waste - Level C; Forklift Operator for Masonary; Form Setter; Green Concrete Cutting; Hand Operated Grouter & Grinder Machine Operator; Jackhammer; Pavement Breaker; Paving Joint Machine; Pipelayer; Plastic Pipe Fusion; Power Driven Georgia Buggy & Wheel Barrow; Power Post Hole Digger; Precast Manhole Setter; Walk-Behind Tamper; Walk-Behind Trencher; Sand Blaster; Concrete Chipper; Surface Grinder; Vibrator Operator; Wagon Driller

GROUP 3 - Asphalt Luteman & Raker; Gunnite Nozzleman; Gunnite Operator & Mixer; Grout Pump Operator; Blaster; Side Rail Setter; Rail Paved Ditches; Screw Operator; Tunnel (Free Air); Water Blaster

GROUP 4 - Caisson Worker (Free Air); Cement Finisher; Environmental - Nuclear, Radiation, Toxic & Hazardous Waste - Levels A & B; Miner & Driller (Free Air); Tunnel Blaster; & Tunnel Mucker (Free Air); Directional & Horizontal Boring; Air Track Drillers (All Types); Powdermen & Blasters; Troxler & Concrete Tester if Laborer is Utilized

 LAB00189-006 07/01/2021

ALLEN, BUTLER, CALDWELL, CHRISTIAN, DAVIESS, EDMONSON, HANCOCK,
 HOPKINS, LOGAN, MCLEAN, MUHLENBERG, OHIO, SIMPSON, TODD, TRIGG
 & WARREN COUNTIES

	Rates	Fringes
Laborers:		
GROUP 1.....	\$ 23.51	16.22
GROUP 2.....	\$ 23.76	16.22
GROUP 3.....	\$ 23.81	16.22
GROUP 4.....	\$ 24.41	16.22

LABORER CLASSIFICATIONS

GROUP 1 - Aging & Curing of Concrete; Asbestos Abatement Worker; Asphalt Plant; Asphalt; Batch Truck Dump; Carpenter Tender; Cement Mason Tender; Cleaning of Machines; Concrete; Demolition; Dredging; Environmental - Nuclear, Radiation, Toxic & Hazardous Waste - Level D; Flagperson; Grade Checker; Hand Digging & Hand Back Filling; Highway Marker Placer; Landscaping, Mesh Handler & Placer; Puddler; Railroad; Rip-rap & Grouter; Right-of-Way; Sign, Guard Rail & Fence Installer; Signal Person; Sound Barrier Installer; Storm & Sanitary Sewer; Swamper; Truck Spotter & Dumper; Wrecking of Concrete Forms; General Cleanup

GROUP 2 - Batter Board Man (Sanitary & Storm Sewer); Brickmason Tender; Mortar Mixer Operator; Scaffold Builder; Burner & Welder; Bushhammer; Chain Saw Operator; Concrete Saw Operator; Deckhand Scow Man; Dry Cement Handler; Environmental - Nuclear, Radiation, Toxic & Hazardous Waste - Level C; Forklift Operator for Masonary; Form Setter; Green Concrete Cutting; Hand Operated Grouter & Grinder Machine Operator; Jackhammer; Pavement Breaker; Paving Joint Machine; Pipelayer; Plastic Pipe Fusion; Power Driven Georgia Buggy & Wheel Barrow; Power Post Hole Digger; Precast Manhole Setter; Walk-Behind Tamper; Walk-Behind Trencher; Sand Blaster; Concrete Chipper; Surface Grinder; Vibrator Operator; Wagon Driller

GROUP 3 - Asphalt Luteman & Raker; Gunnite Nozzleman; Gunnite Operator & Mixer; Grout Pump Operator; Blaster; Side Rail Setter; Rail Paved Ditches; Screw Operator; Tunnel (Free Air); Water Blaster

GROUP 4 - Caisson Worker (Free Air); Cement Finisher; Environmental - Nuclear, Radiation, Toxic & Hazardous Waste - Levels A & B; Miner & Driller (Free Air); Tunnel Blaster; & Tunnel Mucker (Free Air); Directional & Horizontal Boring; Air Track Drillers (All Types); Powdermen & Blasters; Troxler & Concrete Tester if Laborer is Utilized

 LAB00561-001 07/01/2021

CRITTENDEN, HENDERSON, UNION & WEBSTER COUNTIES

	Rates	Fringes
Laborers:		
GROUP 1.....	\$ 24.01	16.60
GROUP 2.....	\$ 24.26	16.60
GROUP 3.....	\$ 24.31	16.60
GROUP 4.....	\$ 24.91	16.60

LABORER CLASSIFICATIONS

GROUP 1 - Aging & Curing of Concrete; Asbestos Abatement Worker; Asphalt Plant; Asphalt; Batch Truck Dump; Carpenter

Tender; Cement Mason Tender; Cleaning of Machines;
 Concrete; Demolition; Dredging; Environmental - Nuclear,
 Radiation, Toxic & Hazardous Waste - Level D; Flagperson;
 Grade Checker; Hand Digging & Hand Back Filling; Highway
 Marker Placer; Landscaping, Mesh Handler & Placer; Puddler;
 Railroad; Rip-rap & Grouter; Right-of-Way; Sign, Guard Rail
 & Fence Installer; Signal Person; Sound Barrier Installer;
 Storm & Sanitary Sewer; Swamper; Truck Spotter & Dumper;
 Wrecking of Concrete Forms; General Cleanup

GROUP 2 - Batter Board Man (Sanitary & Storm Sewer);
 Brickmason Tender; Mortar Mixer Operator; Scaffold Builder;
 Burner & Welder; Bushhammer; Chain Saw Operator; Concrete
 Saw Operator; Deckhand Scow Man; Dry Cement Handler;
 Environmental - Nuclear, Radiation, Toxic & Hazardous Waste
 - Level C; Forklift Operator for Masonary; Form Setter;
 Green Concrete Cutting; Hand Operated Grouter & Grinder
 Machine Operator; Jackhammer; Pavement Breaker; Paving
 Joint Machine; Pipelayer; Plastic Pipe Fusion; Power Driven
 Georgia Buggy & Wheel Barrow; Power Post Hole Digger;
 Precast Manhole Setter; Walk-Behind Tamper; Walk-Behind
 Trencher; Sand Blaster; Concrete Chipper; Surface
 Grinder; Vibrator Operator; Wagon Driller

GROUP 3 - Asphalt Luteman & Raker; Gunnite Nozzleman; Gunnite
 Operator & Mixer; Grout Pump Operator; Blaster; Side Rail
 Setter; Rail Paved Ditches; Screw Operator; Tunnel (Free
 Air); Water Blaster

GROUP 4 - Caisson Worker (Free Air); Cement Finisher;
 Environmental - Nuclear, Radiation, Toxic & Hazardous Waste
 - Levels A & B; Miner & Driller (Free Air); Tunnel Blaster;
 & Tunnel Mucker (Free Air); Directional & Horizontal
 Boring; Air Track Drillers (All Types); Powdermen &
 Blasters; Troxler & Concrete Tester if Laborer is Utilized

 PAIN0032-002 09/01/2020

BALLARD COUNTY

	Rates	Fringes
Painters:		
Bridges.....	\$ 35.01	17.93
All Other Work.....	\$ 32.71	17.93

Spray, Blast, Steam, High & Hazardous (Including Lead
 Abatement) and All Epoxy - \$1.00 Premium

 PAIN0118-003 06/01/2014

EDMONSON COUNTY:

	Rates	Fringes
Painters:		
Brush & Roller.....	\$ 18.50	11.97
Spray, Sandblast, Power Tools, Waterblast & Steam Cleaning.....	\$ 19.50	11.97

 PAIN0156-006 04/01/2015

DAVISS, HANCOCK, HENDERSON, MCLEAN, OHIO, UNION & WEBSTER
 COUNTIES

	Rates	Fringes
Painters:		
BRIDGES		
GROUP 1.....	\$ 27.60	12.85
GROUP 3.....	\$ 28.60	12.85
GROUP 4.....	\$ 29.60	12.85
ALL OTHER WORK:		
GROUP 1.....	\$ 26.45	12.85
GROUP 2.....	\$ 26.70	12.85
GROUP 3.....	\$ 27.45	12.85
GROUP 4.....	\$ 28.45	12.85

PAINTER CLASSIFICATIONS

GROUP 1 - Brush & Roller

GROUP 2 - Plasterers

GROUP 3 - Spray; Sandblast; Power Tools; Waterblast;
 Steamcleaning; Brush & Roller of Mastics, Creosotes, Kwinch
 Koate & Coal Tar Epoxy

GROUP 4 - Spray of Mastics, Creosotes, Kwinch Koate & Coal
 Tar Epoxy

 PAIN0500-002 06/01/2020

CALDWELL, CALLOWAY, CARLISLE, CHRISTIAN, CRITTENDEN, FULTON,
 GRAVES, HICKMAN, HOPKINS, LIVINGSTON, LYON, MARSHALL, MCCRACKEN
 & TRIGG COUNTIES:

	Rates	Fringes
Painters:		
Bridges.....	\$ 27.75	15.10
All Other Work.....	\$ 21.50	15.10

Waterblasting units with 3500 PSI and above - \$.50 premium
 Spraypainting and all abrasive blasting - \$1.00 premium
 Work 40 ft. and above ground level - \$1.00 premium

 PLUM0184-002 07/01/2021

BALLARD, CALDWELL, CALLOWAY, CARLISLE, CHRISTIAN, CRITTENDEN,
 FULTON, GRAVES, HICKMAN, LIVINGSTON, LYON, MARSHALL, MCCRACKEN
 and TRIGG COUNTIES

	Rates	Fringes
Plumber; Steamfitter.....	\$ 37.16	19.03

 PLUM0502-004 08/01/2021

ALLEN, BUTLER, EDMONSON, SIMPSON & WARREN

	Rates	Fringes
--	-------	---------

Plumber; Steamfitter.....\$ 38.07 20.78

PLUM0633-002 07/01/2021

DAVISS, HANCOCK, HENDERSON, HOPKINS, LOGAN, MCLEAN,
MUHLENBERG, OHIO, TODD, UNION & WEBSTER COUNTIES:

 Rates Fringes

PLUMBER/PIPEFITTER.....\$ 33.17 19.30

TEAM0089-003 04/01/2020

ALLEN, BUTLER, EDMONSON, LOGAN, SIMPSON & WARREN COUNTIES

 Rates Fringes

Truck drivers:

 Zone 1:

 Group 1.....\$ 20.82 23.49
 Group 2.....\$ 21.00 23.49
 Group 3.....\$ 21.08 23.49
 Group 4.....\$ 21.10 23.49

GROUP 1 - Greaser; Tire Changer

 GROUP 2 - Truck Mechanic; Single Axle Dump; Flat Bed; All
 Terrain Vehicles when used to haul materials; Semi Trailer
 or Pole Trailer when used to pull building materials and
 equipment; Tandem Axle Dump; Driver of Distributors

GROUP 3 - Mixer All Types

 GROUP 4 - Winch and A-Frame when used in transporting
 materials; Ross Carrier; Fork Lift when used to transport
 building materials; Driver on Pavement Breaker; Euclid and
 Other Heavy Earth Moving Equipment; Low Boy; Articulator
 Cat; Five Axle Vehicle

TEAM0215-003 04/01/2020

DAVISS, HANCOCK, HENDERSON, HOPKINS, MCLEAN, MUHLENBERG, OHIO
& WEBSTER COUNTIES

 Rates Fringes

TRUCK DRIVER

 Group 1.....\$ 22.45 23.49
 Group 2.....\$ 22.68 23.49
 Group 3.....\$ 22.75 23.49
 Group 4.....\$ 22.76 23.49

GROUP 1: Greaser, Tire Changer

GROUP 2: Truck Mechanic

 GROUP 3: Single Axle Dump; Flat Bed; All Terrain Vehicle when
 used to haul materials; Semi Trailer or Pole Trailer when
 used to pull building materials and equipment; Tandem Axle
 Dump; Driver of Distributors; Mixer All Types

GROUP 4: Euclid and other heavy earth moving equipment; Low Boy; Articulator Cat; 5 Axle Vehicle; Winch and A- Frame when used in transporting materials; Ross Carrier; Fork Lift when used to transport building materials; Driver on Pavement Breaker

TEAM0236-001 04/01/2020

BALLARD, CALDWELL, CALLOWAY, CARLISLE, CHRISTIAN, CRITTENDEN, FULTON, GRAVES, HICKMAN, LIVINGSTON, LYON, MARSHALL, MCCRACKEN, TODD & TRIGG COUNTIES

	Rates	Fringes
TRUCK DRIVER		
Group 1.....	\$ 20.82	23.49
Group 2.....	\$ 21.00	23.49
Group 3.....	\$ 21.00	23.49
Group 4.....	\$ 21.00	23.49
Group 5.....	\$ 21.08	23.49

GROUP 1: Greaser, Tire Changer

GROUP 2: Truck Mechanic

GROUP 3: Single Axle Dump; Flat Bed; All Terrain Vehicle when used to haul materials; Semi Trailer or Pole Trailer when used to pull building materials and equipment; Tandem Axle Dump; Drivers of Distributors

GROUP 4: Euclid and other heavy earth moving equipment; Low Boy; Articulator Cat; Five Axle Vehicle; Winch and A-Frame when used in transporting materials; Ross Carrier

GROUP 5: Mixer All Types

WELDERS - Receive rate prescribed for craft performing operation to which welding is incidental.

=====
Note: Executive Order (EO) 13706, Establishing Paid Sick Leave for Federal Contractors applies to all contracts subject to the Davis-Bacon Act for which the contract is awarded (and any solicitation was issued) on or after January 1, 2017. If this contract is covered by the EO, the contractor must provide employees with 1 hour of paid sick leave for every 30 hours they work, up to 56 hours of paid sick leave each year. Employees must be permitted to use paid sick leave for their own illness, injury or other health-related needs, including preventive care; to assist a family member (or person who is like family to the employee) who is ill, injured, or has other health-related needs, including preventive care; or for reasons resulting from, or to assist a family member (or person who is like family to the employee) who is a victim of, domestic violence, sexual assault, or stalking. Additional information on contractor requirements and worker protections under the EO is available at <https://www.dol.gov/agencies/whd/government-contracts>.

Unlisted classifications needed for work not included within

the scope of the classifications listed may be added after award only as provided in the labor standards contract clauses (29CFR 5.5 (a) (1) (ii)).

The body of each wage determination lists the classification and wage rates that have been found to be prevailing for the cited type(s) of construction in the area covered by the wage determination. The classifications are listed in alphabetical order of ""identifiers"" that indicate whether the particular rate is a union rate (current union negotiated rate for local), a survey rate (weighted average rate) or a union average rate (weighted union average rate).

Union Rate Identifiers

A four letter classification abbreviation identifier enclosed in dotted lines beginning with characters other than ""SU"" or ""UAVG"" denotes that the union classification and rate were prevailing for that classification in the survey. Example: PLUM0198-005 07/01/2014. PLUM is an abbreviation identifier of the union which prevailed in the survey for this classification, which in this example would be Plumbers. 0198 indicates the local union number or district council number where applicable, i.e., Plumbers Local 0198. The next number, 005 in the example, is an internal number used in processing the wage determination. 07/01/2014 is the effective date of the most current negotiated rate, which in this example is July 1, 2014.

Union prevailing wage rates are updated to reflect all rate changes in the collective bargaining agreement (CBA) governing this classification and rate.

Survey Rate Identifiers

Classifications listed under the ""SU"" identifier indicate that no one rate prevailed for this classification in the survey and the published rate is derived by computing a weighted average rate based on all the rates reported in the survey for that classification. As this weighted average rate includes all rates reported in the survey, it may include both union and non-union rates. Example: SULA2012-007 5/13/2014. SU indicates the rates are survey rates based on a weighted average calculation of rates and are not majority rates. LA indicates the State of Louisiana. 2012 is the year of survey on which these classifications and rates are based. The next number, 007 in the example, is an internal number used in producing the wage determination. 5/13/2014 indicates the survey completion date for the classifications and rates under that identifier.

Survey wage rates are not updated and remain in effect until a new survey is conducted.

Union Average Rate Identifiers

Classification(s) listed under the UAVG identifier indicate that no single majority rate prevailed for those classifications; however, 100% of the data reported for the classifications was union data. EXAMPLE: UAVG-OH-0010 08/29/2014. UAVG indicates that the rate is a weighted union average rate. OH indicates the state. The next number, 0010 in

the example, is an internal number used in producing the wage determination. 08/29/2014 indicates the survey completion date for the classifications and rates under that identifier.

A UAVG rate will be updated once a year, usually in January of each year, to reflect a weighted average of the current negotiated/CBA rate of the union locals from which the rate is based.

WAGE DETERMINATION APPEALS PROCESS

1.) Has there been an initial decision in the matter? This can be:

- * an existing published wage determination
- * a survey underlying a wage determination
- * a Wage and Hour Division letter setting forth a position on a wage determination matter
- * a conformance (additional classification and rate) ruling

On survey related matters, initial contact, including requests for summaries of surveys, should be with the Wage and Hour National Office because National Office has responsibility for the Davis-Bacon survey program. If the response from this initial contact is not satisfactory, then the process described in 2.) and 3.) should be followed.

With regard to any other matter not yet ripe for the formal process described here, initial contact should be with the Branch of Construction Wage Determinations. Write to:

Branch of Construction Wage Determinations
Wage and Hour Division
U.S. Department of Labor
200 Constitution Avenue, N.W.
Washington, DC 20210

2.) If the answer to the question in 1.) is yes, then an interested party (those affected by the action) can request review and reconsideration from the Wage and Hour Administrator (See 29 CFR Part 1.8 and 29 CFR Part 7). Write to:

Wage and Hour Administrator
U.S. Department of Labor
200 Constitution Avenue, N.W.
Washington, DC 20210

The request should be accompanied by a full statement of the interested party's position and by any information (wage payment data, project description, area practice material, etc.) that the requestor considers relevant to the issue.

3.) If the decision of the Administrator is not favorable, an interested party may appeal directly to the Administrative Review Board (formerly the Wage Appeals Board). Write to:

Administrative Review Board
U.S. Department of Labor
200 Constitution Avenue, N.W.
Washington, DC 20210

4.) All decisions by the Administrative Review Board are final.

=====

END OF GENERAL DECISIO"

Fringe benefit amounts are applicable for all hours worked except when otherwise noted.

No laborer, workman or mechanic shall be paid at a rate less than that of a Journeyman except those classified as bona fide apprentices.

Apprentices or trainees shall be permitted to work as such subject to Administrative Regulations adopted by the Commissioner of Workplace Standards. Copies of these regulations will be furnished upon request from any interested person.

Before using apprentices on the job the contractor shall present to the Contracting Officer written evidence of registration of such employees in a program of a State apprenticeship and training agency approved and recognized by the U. S. Bureau of Apprenticeship and Training. In the absence of such a State agency, the contractor shall submit evidence of approval and registration by the U. S. Bureau of Apprenticeship and Training.

The contractor shall submit to the Contracting Officer, written evidence of the established apprenticeship-journeyman ratios and wage rates in the project area, which will be the basis for establishing such ratios and rates for the project under the applicable contract provisions.

TO: EMPLOYERS/EMPLOYEES

PREVAILING WAGE SCHEDULE:

The wages indicated on this wage schedule are the least permitted to be paid for the occupations indicated. When an employee works in more than one classification, the employer must record the number of hours worked in each classification at the prescribed hourly base rate.

OVERTIME:

Overtime is to be paid to an employee at a rate not less than one and one-half times the basic rate of pay for all hours worked in excess of forty (40) hours in such workweek. Wage violations or questions should be directed to the designated Engineer or the undersigned.

Director
Division of Construction Procurement
Frankfort, Kentucky 40622
502-564-3500

**NOTICE OF REQUIREMENT FOR AFFIRMATIVE ACTION
TO ENSURE EQUAL EMPLOYMENT OPPORTUNITY
(Executive Order 11246)**

1. The Offeror's or Bidder's attention is called to the "Equal Opportunity Clause" and the "Standard Federal Equal Employment Specifications" set forth herein.
2. The goals and timetables for minority and female participation, expressed in percentage terms for the Contractor's aggregate work force in each trade on all construction work in the covered area, are as follows:

GOALS FOR MINORITY PARTICIPATION IN EACH TRADE	GOALS FOR FEMALE PARTICIPATION IN EACH TRADE
12.0%	6.9%

These goals are applicable to all the Contractor's construction work (whether or not it is Federal or federally-assisted) performed in the covered area. If the contractor performs construction work in a geographical area located outside of the covered area, it shall apply the goals established for such geographical area where the work is actually performed. With regard to this second area, the contractor also is subject to the goals for both its federally involved and non-federally involved construction.

The Contractor's compliance with the Executive Order and the regulations in CFR Part 60-4 shall be based on its implementation of the Equal Opportunity Clause, specific affirmative action obligations required by the specifications set forth in 41 CFR 60-4, 3(a), and its efforts to meet the goals. The hours of minority and female employment and training must be substantially uniform throughout the length of the contract, and in each trade, and the contractor shall make a good faith effort to employ minorities and women evenly on each of its projects. The transfer of minority or female employees or trainees from Contractor to Contractor or from project to project for the sole purpose of meeting the Contractor's goals shall be a violation of the contract, the Executive Order and the regulations in 41 CFR Part 60-4. Compliance with the goals will be measured against the total work hours performed.

3. The Contractor shall provide written notification to the Director of the Office of Federal Contract Compliance Programs within ten (10) working days of award of any construction subcontract in excess of \$10,000.00 at any tier for construction work under the contract resulting from this solicitation. The notification shall list the name, address and telephone number of the subcontractor; employer identification number of the subcontractor; estimated dollar amount of the subcontract; estimated starting and completion dates of the subcontract; and the geographical area in which the subcontract is to be performed. The notification shall be mailed to:

**Evelyn Teague, Regional Director
Office of Federal Contract Compliance Programs
61 Forsyth Street, SW, Suite 7B75
Atlanta, Georgia 30303-8609**

4. As used in this Notice, and in the contract resulting from this solicitation, the "**covered area**" is Warren County.

PART IV
INSURANCE

Refer to
Kentucky Standard Specifications for Road and Bridge Construction,
current edition

PART V
BID ITEMS

PROPOSAL BID ITEMS

224430

Page 1 of 2

Report Date 4/27/22

Section: 0001 - ROADWAY

LINE	BID CODE	ALT	DESCRIPTION	QUANTITY	UNIT	UNIT PRIC	FP	AMOUNT
0010	00001		DGA BASE	20.50	TON		\$	
0020	01917		STANDARD BARRIER MEDIAN TYPE 2	48.00	SQYD		\$	
0030	02200		ROADWAY EXCAVATION	15.50	CUYD		\$	
0040	02562		TEMPORARY SIGNS	150.00	SQFT		\$	
0050	02650		MAINTAIN & CONTROL TRAFFIC (WARREN US 31W)	1.00	LS		\$	
0060	02671		PORTABLE CHANGEABLE MESSAGE SIGN	2.00	EACH		\$	
0070	02703		SILT TRAP TYPE A	1.00	EACH		\$	
0080	02704		SILT TRAP TYPE B	1.00	EACH		\$	
0090	02705		SILT TRAP TYPE C	1.00	EACH		\$	
0100	02706		CLEAN SILT TRAP TYPE A	1.00	EACH		\$	
0110	02707		CLEAN SILT TRAP TYPE B	1.00	EACH		\$	
0120	02708		CLEAN SILT TRAP TYPE C	1.00	EACH		\$	
0130	02726		STAKING (WARREN US 31W)	1.00	LS		\$	
0140	06546		PAVE STRIPING-THERMO-12 IN W	404.00	LF		\$	
0150	06568		PAVE MARKING-THERMO STOP BAR-24IN	70.00	LF		\$	
0160	20430ED		SAW CUT	85.00	LF		\$	
0170	22950NN		PAVE MARKING-THERMO STOP	2.00	EACH		\$	

Section: 0002 - SIGNING

LINE	BID CODE	ALT	DESCRIPTION	QUANTITY	UNIT	UNIT PRIC	FP	AMOUNT
0180	06406		SBM ALUM SHEET SIGNS .080 IN	6.00	SQFT		\$	
0190	06407		SBM ALUM SHEET SIGNS .125 IN	140.00	SQFT		\$	
0200	06410		STEEL POST TYPE 1	130.00	LF		\$	
0210	24631EC		BARCODE SIGN INVENTORY	10.00	EACH		\$	

Section: 0003 - SIGNALIZATION

LINE	BID CODE	ALT	DESCRIPTION	QUANTITY	UNIT	UNIT PRIC	FP	AMOUNT
0220	04792		CONDUIT-1 IN	40.00	LF		\$	
0230	04795		CONDUIT-2 IN	450.00	LF		\$	
0240	04811		ELECTRICAL JUNCTION BOX TYPE B	10.00	EACH		\$	
0250	04820		TRENCHING AND BACKFILLING	850.00	LF		\$	
0260	04821		OPEN CUT ROADWAY	450.00	LF		\$	
0270	04830		LOOP WIRE	825.00	LF		\$	
0280	04845		CABLE-NO. 14/7C	1,850.00	LF		\$	
0290	04850		CABLE-NO. 14/1 PAIR	1,700.00	LF		\$	
0300	04885		MESSENGER-10800 LB	175.00	LF		\$	
0310	04895		LOOP SAW SLOT AND FILL	325.00	LF		\$	
0320	04932		INSTALL STEEL STRAIN POLE	2.00	EACH		\$	
0330	20390NS835		INSTALL COORDINATING UNIT	1.00	EACH		\$	
0340	20408ES835		INSTALL LED BEACON-12 IN	8.00	EACH		\$	
0350	21543EN		BORE AND JACK CONDUIT	450.00	LF		\$	

PROPOSAL BID ITEMS

224430

Page 2 of 2

Report Date 4/27/22

LINE	BID CODE	ALT	DESCRIPTION	QUANTITY	UNIT	UNIT PRIC	FP	AMOUNT
0360	23157EN		TRAFFIC SIGNAL POLE BASE	7.00	CUYD		\$	
0370	24525EC		ADVANCE WARNING FLASHER	2.00	EACH		\$	
0380	24900EC		PVC CONDUIT-1 1/4 IN-SCHEDULE 80	810.00	LF		\$	
0390	24908EC		INSTALL SIGNAL CONTROLLER-TY ATC	1.00	EACH		\$	
0400	24955ED		REMOVE SIGNAL EQUIPMENT	1.00	EACH		\$	

Section: 0004 - DEMOBILIZATION

LINE	BID CODE	ALT	DESCRIPTION	QUANTITY	UNIT	UNIT PRIC	FP	AMOUNT
0410	02569		DEMOBILIZATION	1.00	LS		\$	