



**CALL NO. 105**

**CONTRACT ID. 211351**

**JEFFERSON COUNTY**

**FED/STATE PROJECT NUMBER HSIP 8744 (005)**

**DESCRIPTION FEGENBUSH LANE(KY-864)**

**WORK TYPE GRADE & DRAIN WITH ASPHALT SURFACE**

**PRIMARY COMPLETION DATE 7/31/2022**

**LETTING DATE: November 19,2021**

Sealed Bids will be received electronically through the Bid Express bidding service until 10:00 am EASTERN STANDARD TIME November 19,2021. Bids will be publicly announced at 10:00 am EASTERN STANDARD TIME.

**PLANS AVAILABLE FOR THIS PROJECT.**

**DBE CERTIFICATION REQUIRED - 0%**

**REQUIRED BID PROPOSAL GUARANTY: Not less than 5% of the total bid.**

## TABLE OF CONTENTS

|          |   |
|----------|---|
| PART I   | SCOPE OF WORK   |
|          | <ul style="list-style-type: none"><li>• PROJECT(S), COMPLETION DATE(S), &amp; LIQUIDATED DAMAGES</li><li>• CONTRACT NOTES</li><li>• FEDERAL CONTRACT NOTES</li><li>• ASPHALT MIXTURE</li><li>• DGA BASE</li><li>• DGA BASE FOR SHOULDERS</li><li>• INCIDENTAL SURFACING</li><li>• COMPACTION OPTION B</li><li>• SPECIAL NOTE(S) APPLICABLE TO PROJECT</li><li>• SPECIAL NOTE FOR NON-TRACKING TACK COAT</li><li>• RIGHT OF WAY CERTIFICATION</li><li>• UTILITY IMPACT &amp; RAIL CERTIFICATION NOTES</li><li>• GENERAL UTILITY NOTES</li><li>• WATER STANDARD UTILITY BID ITEMS</li><li>• WATERLINE SPECIFICATIONS</li><li>• KPDES STORM WATER PERMIT, BMP AND ENOI</li></ul> |
| PART II  | SPECIFICATIONS AND STANDARD DRAWINGS  |
|          | <ul style="list-style-type: none"><li>• SPECIFICATIONS REFERENCE</li><li>• SUPPLEMENTAL SPECIFICATION</li><li>• [SN-1I] PORTABLE CHANGEABLE SIGNS</li><li>• [SN-11N] LONGITUDINAL PAVEMENT JOINT ADHESIVE</li></ul>   |
| PART III | EMPLOYMENT, WAGE AND RECORD REQUIREMENTS  |
|          | <ul style="list-style-type: none"><li>• FEDERAL-AID CONSTRUCTION CONTRACTS - FHWA 1273</li><li>• NONDISCRIMINATION OF EMPLOYEES</li><li>• EXECUTIVE BRANCH CODE OF ETHICS</li><li>• PROJECT WAGE RATES LOCALITY 3 / FEDERAL</li><li>• NOTICE OF REQUIREMENT FOR AFFIRMATIVE ACTION TO ENSURE EEO JEFFERSON</li></ul>  |
| PART IV  | INSURANCE   |
| PART V   | BID ITEMS   |

**PART I**  
**SCOPE OF WORK**

## ADMINISTRATIVE DISTRICT - 05

**CONTRACT ID - 211351**

**HSIP 8744 (005)**

**COUNTY - JEFFERSON**

**PCN - DE05608642035**

**HSIP 8744 (005)**

FEGENBUSH LANE(KY-864) CONSTRUCT LEFT TURN LANE AT FENWICK DRIVE AND FEGENBUSH LANE, A  
DISTANCE OF 0.16 MILES.GRADE & DRAIN WITH ASPHALT SURFACE SYP NO. 05-09016.00.  
GEOGRAPHIC COORDINATES LATITUDE 38:09:18.00 LONGITUDE 85:38:11.00

**COMPLETION DATE(S):**

COMPLETED BY 07/31/2022

APPLIES TO ENTIRE CONTRACT

## **CONTRACT NOTES**

### **PROPOSAL ADDENDA**

All addenda to this proposal must be applied when calculating bid and certified in the bid packet submitted to the Kentucky Department of Highways. Failure to use the correct and most recent addenda may result in the bid being rejected.

### **BID SUBMITTAL**

Bidder must use the Department's electronic bidding software. The Bidder must download the bid file located on the Bid Express website ([www.bidx.com](http://www.bidx.com)) to prepare a bid packet for submission to the Department. The bidder must submit electronically using Bid Express.

### **JOINT VENTURE BIDDING**

Joint venture bidding is permissible. All companies in the joint venture must be prequalified in one of the work types in the Qualifications for Bidders for the project. The bidders must get a vendor ID for the joint venture from the Division of Construction Procurement and register the joint venture as a bidder on the project. Also, the joint venture must obtain a digital ID from Bid Express to submit a bid. A joint bid bond of 5% may be submitted for both companies or each company may submit a separate bond of 5%.

### **UNDERGROUND FACILITY DAMAGE PROTECTION**

The contractor shall make every effort to protect underground facilities from damage as prescribed in the Underground Facility Damage Protection Act of 1994, Kentucky Revised Statute KRS 367.4901 to 367.4917. It is the contractor's responsibility to determine and take steps necessary to be in compliance with federal and state damage prevention directives. When prescribed in said directives, the contractor shall submit Excavation Locate Requests to the Kentucky Contact Center (KY811) via web ticket entry. The submission of this request does not relieve the contractor from the responsibility of contacting non-member facility owners, whom shall be contacted through their individual Protection Notification Center. Non-compliance with these directives can result in the enforcement of penalties.

### **REGISTRATION WITH THE SECRETARY OF STATE BY A FOREIGN ENTITY**

Pursuant to KRS 176.085(1)(b), an agency, department, office, or political subdivision of the Commonwealth of Kentucky shall not award a state contract to a person that is a foreign entity required by [KRS 14A.9-010](#) to obtain a certificate of authority to transact business in the Commonwealth ("certificate") from the Secretary of State under [KRS 14A.9-030](#) unless the person produces the certificate within fourteen (14) days of the bid or proposal opening. If the foreign entity is not required to obtain a certificate as provided in [KRS 14A.9-010](#), the foreign entity should identify the applicable exception. Foreign entity is defined within [KRS 14A.1-070](#).

**For all foreign entities required to obtain a certificate of authority to transact business in the Commonwealth, if a copy of the certificate is not received by the contracting agency within the time frame identified above, the foreign entity's solicitation response shall be deemed non-responsive or the awarded contract shall be cancelled.**

Businesses can register with the Secretary of State at <https://secure.kentucky.gov/sos/ftbr/welcome.aspx>.

### **SPECIAL NOTE FOR PROJECT QUESTIONS DURING ADVERTISEMENT**

Questions about projects during the advertisement should be submitted in writing to the Division of Construction Procurement. This may be done by fax (502) 564-7299 or email to [kytc.projectquestions@ky.gov](mailto:kytc.projectquestions@ky.gov). The Department will attempt to answer all submitted questions. The Department reserves the right not to answer if the question is not pertinent or does not aid in clarifying the project intent.

The deadline for posting answers will be 3:00 pm Eastern Daylight Time, the day preceding the Letting. Questions may be submitted until this deadline with the understanding that the later a question is submitted, the less likely an answer will be able to be provided.

The questions and answers will be posted for each Letting under the heading "Questions & Answers" on the Construction Procurement website ([www.transportation.ky.gov/contract](http://www.transportation.ky.gov/contract)). The answers provided shall be considered part of this Special Note and, in case of a discrepancy, will govern over all other bidding documents.

### **HARDWOOD REMOVAL RESTRICTIONS**

The US Department of Agriculture has imposed a quarantine in Kentucky and several surrounding states, to prevent the spread of an invasive insect, the emerald ash borer. Hardwood cut in conjunction with the project may not be removed from the state. Chipping or burning on site is the preferred method of disposal.

### **INSTRUCTIONS FOR EXCESS MATERIAL SITES AND BORROW SITES**

Identification of excess material sites and borrow sites shall be the responsibility of the Contractor. The Contractor shall be responsible for compliance with all applicable state and federal laws and may wish to consult with the US Fish and Wildlife Service to seek protection under Section 10 of the Endangered Species Act for these activities.

### **ACCESS TO RECORDS**

The contractor, as defined in KRS 45A.030 (9) agrees that the contracting agency, the Finance and Administration Cabinet, the Auditor of Public Accounts, and the Legislative Research Commission, or their duly authorized representatives, shall have access to any books, documents, papers, records, or other evidence, which are directly pertinent to this contract for the purpose of financial audit or program review. Records and other prequalification information confidentially

disclosed as part of the bid process shall not be deemed as directly pertinent to the contract and shall be exempt from disclosure as provided in KRS 61.878(1)(c). The contractor also recognizes that any books, documents, papers, records, or other evidence, received during a financial audit or program review shall be subject to the Kentucky Open Records Act, KRS 61.870 to 61.884.

In the event of a dispute between the contractor and the contracting agency, Attorney General, or the Auditor of Public Accounts over documents that are eligible for production and review, the Finance and Administration Cabinet shall review the dispute and issue a determination, in accordance with Secretary's Order 11-004.

April 30, 2018

### **FEDERAL CONTRACT NOTES**

The Kentucky Department of Highways, in accordance with the Regulations of the United States Department of Transportation 23 CFR 635.112 (h), hereby notifies all bidders that failure by a bidder to comply with all applicable sections of the current Kentucky Standard Specifications, including, but not limited to the following, may result in a bid not being considered responsive and thus not eligible to be considered for award:

- |                                |  |
|--------------------------------|--|
| 102.02 Current Rating          | 102.08 Preparation and Delivery of Proposals |
| 102.13 Irregular Bid Proposals | 102.14 Disqualification of Bidders           |
| 102.09 Proposal Guaranty       |  |

### **CIVIL RIGHTS ACT OF 1964**

The Kentucky Department of Highways, in accordance with the provisions of Title VI of the Civil Rights Act of 1964 (78 Stat. 252) and the Regulations of the Federal Department of Transportation (49 C.F.R., Part 21), issued pursuant to such Act, hereby notifies all bidders that it will affirmatively insure that the contract entered into pursuant to this advertisement will be awarded to the lowest responsible bidder without discrimination on the ground of race, color, or national origin.

### **NOTICE TO ALL BIDDERS**

To report bid rigging activities call: 1-800-424-9071.

The U.S. Department of Transportation (DOT) operates the above toll-free “hotline” Monday through Friday, 8:00 a.m. to 5:00 p.m. eastern time. Anyone with knowledge of possible bid rigging, bidder collusion, or other fraudulent activities should use the “hotline” to report such activities.

The “hotline” is part of the DOT’s continuing effort to identify and investigate highway construction contract fraud and abuse and is operated under the direction of the DOT Inspector General. All information will be treated confidentially and caller anonymity will be respected.

### **SECOND TIER SUBCONTRACTS**

Second tier subcontracts are acceptable per Section 108.01 of the Standard Specifications for Road and Bridge Construction. There are special rules to DBE subcontractors satisfying DBE goals on federal-aid projects. 1<sup>st</sup>-Tier DBE Subcontractors may only enter into a 2<sup>nd</sup>-Tier subcontract with another DBE contractor.

### **DISADVANTAGED BUSINESS ENTERPRISE PROGRAM**

It is the policy of the Kentucky Transportation Cabinet (“the Cabinet”) that Disadvantaged Business Enterprises (“DBE”) shall have the opportunity to participate in the performance of highway construction projects financed in whole or in part by Federal Funds in order to create a level playing field for all businesses who wish to contract with the Cabinet. To that end, the Cabinet will comply with the regulations found in 49 CFR Part 26, and the definitions and requirements contained therein shall be adopted as if set out verbatim herein.

The Cabinet, contractors, subcontractors, and sub-recipients shall not discriminate on the basis of race, color, national origin, or sex in the performance of work performed pursuant to Cabinet contracts. The contractor shall carry out applicable requirements of 49 CFR 26 in the award and administration of federally assisted highway construction projects. The contractor will include this provision in all its subcontracts and supply agreements pertaining to contracts with the Cabinet.

Failure by the contractor to carry out these requirements is a material breach of its contract with the Cabinet, which may result in the termination of the contract or such other remedy as the Cabinet deems necessary.

### **DBE GOAL**

The Disadvantaged Business Enterprise (DBE) goal established for this contract, as listed on the front page of the proposal, is the percentage of the total value of the contract.

The contractor shall exercise all necessary and reasonable steps to ensure that Disadvantaged Business Enterprises participate in a least the percent of the contract as set forth above as goals for this contract.

### **OBLIGATION OF CONTRACTORS**

Each contractor prequalified to perform work on Cabinet projects shall designate and make known to the Cabinet a liaison officer who is assigned the responsibility of effectively administering and promoting an active program for utilization of DBEs.

If a formal goal has not been designated for the contract, all contractors are encouraged to consider DBEs for subcontract work as well as for the supply of material and services needed to perform this work.

Contractors are encouraged to use the services of banks owned and controlled by minorities and women.

### **CERTIFICATION OF CONTRACT GOAL**

Contractors shall include the following certification in bids for projects for which a DBE goal has been established. BIDS SUBMITTED WHICH DO NOT INCLUDE CERTIFICATION OF DBE PARTICIPATION WILL NOT BE ACCEPTED. These bids will not be considered for award by the Cabinet and they will be returned to the bidder.

“The bidder certifies that it has secured participation by Disadvantaged Business Enterprises (“DBE”) in the amount of \_\_\_\_\_ percent of the total value of this contract and that the DBE participation is in compliance with the requirements of 49 CFR 26 and the policies of the Kentucky Transportation Cabinet pertaining to the DBE Program.”

**The certification statement is located in the electronic bid file. All contractors must certify their DBE participation on that page. DBEs utilized in achieving the DBE goal must be certified and prequalified for the work items at the time the bid is submitted.**

### **DBE PARTICIPATION PLAN**

Lowest responsive bidders must submit the *DBE Plan/ Subcontractor Request*, form TC 14-35 DBE, within **5** days of the letting. This is necessary before the Awards Committee will review and make a recommendation. **The project will not be considered for award prior to submission and approval of the apparent low bidder’s DBE Plan/Subcontractor Request.**

The DBE Participation Plan shall include the following:

1. Name and address of DBE Subcontractor(s) and/or supplier(s) intended to be used in the proposed project;
2. Description of the work each is to perform including the work item, unit, quantity, unit price and total amount of the work to be performed by the individual DBE. The Proposal Line Number, Category Number, and the Project Line Number can be found in the “material listing” on the Construction Procurement website under the specific letting;
3. The dollar value of each proposed DBE subcontract and the percentage of total project contract value this represents. DBE participation may be counted as follows:
  - a. If DBE suppliers and manufactures assume actual and contractual responsibility, the dollar value of materials to be furnished will be counted toward the goal as follows:
    - The entire expenditure paid to a DBE manufacturer;
    - 60 percent of expenditures to DBE suppliers that are not manufacturers provided the supplier is a regular dealer in the product involved. A regular dealer must be engaged in, as its principal business and in its own name, the sale of products to the public, maintain an inventory and own and operate distribution equipment; and
    - The amount of fees or commissions charged by the DBE firms for a bona fide service, such as professional, technical, consultant, or managerial services and assistance in the procurement of essential personnel, facilities, equipment, materials, supplies, delivery of materials and supplies or for furnishing bonds, or insurance, providing such fees or commissions are determined to be reasonable and customary.

- b) The dollar value of services provided by DBEs such as quality control testing, equipment repair and maintenance, engineering, staking, etc.;
  - c) The dollar value of joint ventures. DBE credit for joint ventures will be limited to the dollar amount of the work actually performed by the DBE in the joint venture;
4. Written and signed documentation of the bidder's commitment to use a DBE contractor whose participation is being utilized to meet the DBE goal; and
  5. Written and signed confirmation from the DBE that it is participating in the contract as provided in the prime contractor's commitment.

#### **UPON AWARD AND BEFORE A WORK ORDER WILL BE ISSUED**

Contractors must submit the signed subcontract between the contractor and the DBE contractor, along with the DBE's certificate of insurance. If the DBE is a supplier of materials for the project, a signed purchase order must be submitted to the Division of Construction Procurement.

Changes to DBE Participation Plans must be approved by the Cabinet. The Cabinet may consider extenuating circumstances including, but not limited to, changes in the nature or scope of the project, the inability or unwillingness of a DBE to perform the work in accordance with the bid, and/or other circumstances beyond the control of the prime contractor.

#### **CONSIDERATION OF GOOD FAITH EFFORTS REQUESTS**

If the DBE participation submitted in the bid by the apparent lowest responsive bidder does not meet or exceed the DBE contract goal, the apparent lowest responsive bidder must submit a Good Faith Effort Package to satisfy the Cabinet that sufficient good faith efforts were made to meet the contract goals prior to submission of the bid. Efforts to increase the goal after bid submission will not be considered in justifying the good faith effort, unless the contractor can show that the proposed DBE was solicited prior to the letting date. DBEs utilized in achieving the DBE goal must be certified and prequalified for the work items at the time the bid is submitted. One complete set (hard copy along with an electronic copy) of this information must be received in the Division of Contract Procurement no later than 12:00 noon of the tenth calendar day after receipt of notification that they are the apparent low bidder.

Where the information submitted includes repetitious solicitation letters it will be acceptable to submit a sample representative letter along with a distribution list of the firms solicited. Documentation of DBE quotations shall be a part of the good faith effort submittal as necessary to demonstrate compliance with the factors listed below which the Cabinet considers in judging good faith efforts. This documentation may include written subcontractors' quotations, telephone log notations of verbal quotations, or other types of quotation documentation.

The Good Faith Effort Package shall include, but may not be limited to information showing evidence of the following:

1. Whether the bidder attended any pre-bid meetings that were scheduled by the Cabinet to inform DBEs of subcontracting opportunities;
2. Whether the bidder provided solicitations through all reasonable and available means;
3. Whether the bidder provided written notice to all DBEs listed in the DBE directory at the time of the letting who are prequalified in the areas of work that the bidder will be subcontracting;
4. Whether the bidder followed up initial solicitations of interest by contacting DBEs to determine with certainty whether they were interested. If a reasonable amount of DBEs within the targeted districts do not provide an intent to quote or no DBEs are prequalified in the subcontracted areas, the bidder must notify the Disadvantaged Enterprise Business Liaison Officer (DEBLO) in the Office of Civil Rights and Small Business Development to give notification of the bidder's inability to get DBE quotes;
5. Whether the bidder selected portions of the work to be performed by DBEs in order to increase the likelihood of meeting the contract goals. This includes, where appropriate, breaking out contract work items into economically feasible units to facilitate DBE participation, even when the prime contractor might otherwise perform these work items with its own forces;
6. Whether the bidder provided interested DBEs with adequate and timely information about the plans, specifications, and requirements of the contract;
7. Whether the bidder negotiated in good faith with interested DBEs not rejecting them as unqualified without sound reasons based on a thorough investigation of their capabilities. Any rejection should be so noted in writing with a description as to why an agreement could not be reached;
8. Whether quotations were received from interested DBE firms but were rejected as unacceptable without sound reasons why the quotations were considered unacceptable. The fact that the DBE firm's quotation for the work is not the lowest quotation received will not in itself be considered as a sound reason for rejecting the quotation as unacceptable. The fact that the bidder has the ability and/or desire to perform the contract work with its own forces will not be considered a sound reason for rejecting a DBE quote. Nothing in this provision shall be construed to require the bidder to accept unreasonable quotes in order to satisfy DBE goals;
9. Whether the bidder specifically negotiated with subcontractors to assume part of the responsibility to meet the contract DBE goal when the work to be subcontracted includes potential DBE participation;
10. Whether the bidder made any efforts and/or offered assistance to interested DBEs in obtaining the necessary equipment, supplies, materials, insurance and/or bonding to satisfy the work requirements of the bid proposal; and
11. Any other evidence that the bidder submits which may show that the bidder has made reasonable good faith efforts to include DBE participation.

### **FAILURE TO MEET GOOD FAITH REQUIREMENT**

Where the apparent lowest responsive bidder fails to submit sufficient participation by DBE firms to meet the contract goal and upon a determination by the Good Faith Committee based upon the information submitted that the apparent lowest responsive bidder failed to make sufficient reasonable efforts to meet the contract goal, the bidder will be offered the opportunity to meet in person for administrative reconsideration. The bidder will be notified of the Committee's decision within 24 hours of its decision. The bidder will have 24 hours to request reconsideration of the Committee's decision. The reconsideration meeting will be held within two days of the receipt of a request by the bidder for reconsideration.

The request for reconsideration will be heard by the Office of the Secretary. The bidder will have the opportunity to present written documentation or argument concerning the issue of whether it met the goal or made an adequate good faith effort. The bidder will receive a written decision on the reconsideration explaining the basis for the finding that the bidder did or did not meet the goal or made adequate Good Faith efforts to do so.

The result of the reconsideration process is not administratively appealable to the Cabinet or to the United States Department of Transportation.

The Cabinet reserves the right to award the contract to the next lowest responsive bidder or to rebid the contract in the event that the contract is not awarded to the low bidder as the result of a failure to meet the good faith requirement.

### **SANCTIONS FOR FAILURE TO MEET DBE REQUIREMENTS OF THE PROJECT**

Failure by the prime contractor to fulfill the DBE requirements of a project under contract or to demonstrate good faith efforts to meet the goal constitutes a breach of contract. When this occurs, the Cabinet will hold the prime contractor accountable, as would be the case with all other contract provisions. Therefore, the contractor's failure to carry out the DBE contract requirements shall constitute a breach of contract and as such the Cabinet reserves the right to exercise all administrative remedies at its disposal including, but not limited to the following:

- Suspension of Prequalification;
- Disallow credit toward the DBE goal;
- Withholding progress payments;
- Withholding payment to the prime in an amount equal to the unmet portion of the contract goal; and/or
- Termination of the contract.

### **PROMPT PAYMENT**

The prime contractor will be required to pay the DBE and Non-DBE Subcontractors within seven (7) working days after he or she has received payment from the Kentucky Transportation Cabinet for work performed or materials furnished.

### **CONTRACTOR REPORTING**

All contractors must keep detailed records and provide reports to the Cabinet on their progress in meeting the DBE requirement on any highway contract. These records may include, but shall not be limited to payroll, lease agreements, cancelled payroll checks, executed subcontracting agreements, etc. Prime contractors will be required to complete and submit a **signed and notarized** Affidavit of Subcontractor Payment (TC 18-7) and copies of checks for any monies paid to each DBE subcontractor or supplier utilized to meet a DBE goal. These documents must be completed and signed within 7 days of being paid by the Cabinet.

Payment information that needs to be reported includes date the payment is sent to the DBE, check number, Contract ID, amount of payment and the check date. Before Final Payment is made on this contract, the Prime Contractor will certify that all payments were made to the DBE subcontractor and/or DBE suppliers.

**\*\*\*\*\* IMPORTANT \*\*\*\*\***

**Please mail the original, signed and completed TC (18-7) Affidavit of Subcontractor Payment form and all copies of checks for payments listed above to the following address:**

Office of Civil Rights and Small Business Development  
6<sup>th</sup> Floor West 200 Mero Street  
Frankfort, KY 40622

The prime contractor should notify the KYTC Office of Civil Rights and Small Business Development seven (7) days prior to DBE contractors commencing work on the project. The contact in this office is Mr. Melvin Bynes. Mr. Bynes' current contact information is email address – [melvin.bynes2@ky.gov](mailto:melvin.bynes2@ky.gov) and the telephone number is (502) 564-3601.

### **DEFAULT OR DECERTIFICATION OF THE DBE**

If the DBE subcontractor or supplier is decertified or defaults in the performance of its work, and the overall goal cannot be credited for the uncompleted work, the prime contractor may utilize a substitute DBE or elect to fulfill the DBE goal with another DBE on a different work item. If after exerting good faith effort in accordance with the Cabinet's Good Faith Effort policies and procedures, the prime contractor is unable to replace the DBE, then the unmet portion of the goal may be waived at the discretion of the Cabinet.

### **PROHIBITION ON TELECOMMUNICATIONS EQUIPMENT OR SERVICES**

In accordance with the FY 2019 National Defense Authorization Act (NDAA), 2 CFR 200.216, and 2 CFR 200.471, Federal agencies are prohibited, after August 13, 2020, from obligating or expending financial assistance to obtain certain telecommunications and video surveillance services and equipment from specific producers. As a result of these regulations, contractors and subcontractors are prohibited, on projects with federal funding participation, from providing telecommunication or video surveillance equipment, services, or systems produced by:

- Huawei Technologies Company or ZTE Corporation (or any subsidiary or affiliate of such entities)
- Hytera Communications Corporation, Hangzhou Hikvision Digital Technology Company, or Dahua Technology Company (or any subsidiary or affiliate of such entities)

**LEGAL REQUIREMENTS AND RESPONSIBILITY TO THE PUBLIC – CARGO PREFERENCE ACT (CPA).**

**(REV 12-17-15) (1-16)**

SECTION 7 is expanded by the following new Article:

102.10 **Cargo Preference Act – Use of United States-flag vessels.**

Pursuant to Title 46CFR Part 381, the Contractor agrees

- To utilize privately owned United States-flag commercial vessels to ship at least 50 percent of the gross tonnage (computed separately for dry bulk carriers, dry cargo liners, and tankers) involved, whenever shipping any equipment, material, or commodities pursuant to this contract, to the extent such vessels are available at fair and reasonable rates for United States-flag commercial vessels.

- To furnish within 20 days following the date of loading for shipments originating within the United States or within 30 working days following the date of loading for shipments originating outside the United States, a legible copy of a rated, 'on-board' commercial ocean bill-of-lading in English for each shipment of cargo described in paragraph 1 of this section to both the Contracting Officer (through the prime contractor in the case of subcontractor bills-of-lading) and to the Division of National Cargo, Office of Market Development, Maritime Administration, Washington, DC 20590.

- To insert the substance of the provisions of this clause in all subcontracts issued pursuant to this contract.

### **ASPHALT MIXTURE**

Unless otherwise noted, the Department estimates the rate of application for all asphalt mixtures to be 110 lbs/sy per inch of depth.

### **DGA BASE**

Unless otherwise noted, the Department estimates the rate of application for DGA Base to be 115 lbs/sy per inch of depth.

### **DGA BASE FOR SHOULDERS**

Unless otherwise noted, the Department estimates the rate of application for DGA Base for Shoulders to be 115 lbs/sy per inch of depth. The Department will not measure necessary grading and/or shaping of existing shoulders prior to placing of DGA Base, but shall be incidental to the Contract unit price per ton for DGA Base.

Accept payment at the Contract unit price per ton as full compensation for all labor, materials, equipment, and incidentals for grading and/or shaping of existing shoulders and furnishing, placing, and compacting the DGA Base.

### **INCIDENTAL SURFACING**

The Department has included in the quantities of asphalt mixtures established in the proposal estimated quantities required for resurfacing or surfacing mailbox turnouts, farm field entrances, residential and commercial entrances, curve widening, ramp gores and tapers, and road and street approaches, as applicable. Pave these areas to the limits as shown on Standard Drawing RPM-110-06 or as directed by the Engineer. In the event signal detectors are present in the intersecting streets or roads, pave the crossroads to the right of way limit or back of the signal detector, whichever is the farthest back of the mainline. Surface or resurface these areas as directed by the Engineer. The Department will not measure placing and compacting for separate payment but shall be incidental to the Contract unit price for the asphalt mixtures.

### **OPTION B**

Be advised that the Department will control and accept compaction of asphalt mixtures furnished on this project under OPTION B in accordance with Sections 402 and 403.

# 5-9016.00 - PROJECT LOCATION MAP

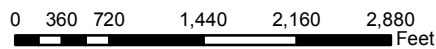
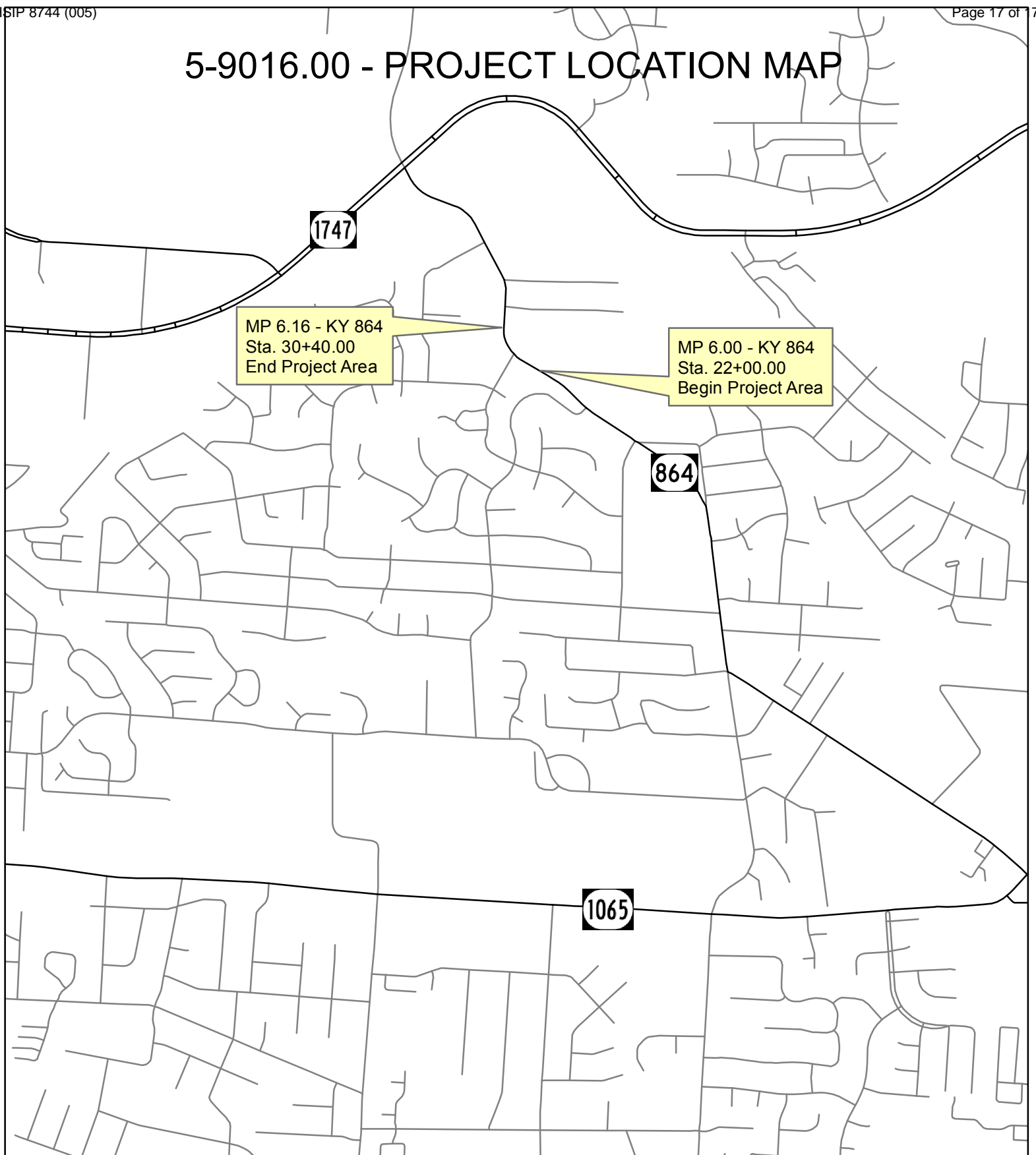

JEFFERSON COUNTY  
ITEM NO. 5-9016.00  
CONSTRUCT LEFT TURN LANE  
KY 864 (FEGENBUSH LANE)  
AT FENWICK DRIVE

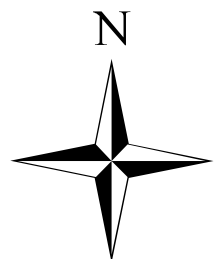

# KENTUCKY TRANSPORTATION CABINET DEPARTMENT OF HIGHWAYS TRAFFIC MANAGEMENT PLAN

County: Jefferson Item No.: 5-9016.00

Federal Project No.: HSIP 8744 005

**Project Description:**

Widen KY 864 to create a northbound left turn lane

Roadway Classification:  Urban  Rural  
 Local  Collector  Arterial  Interstate

ADT (current) 12,339\* AM Peak Current \_\_\_\_\_ PM Peak Current \_\_\_\_\_ % Trucks 4.0%

Project Designation:  Significant  Other: \_\_\_\_\_

**Traffic Control Plan Design:**

Taper and Diversion Design Speeds See Traffic Control Plan

Minimum Lane Width 10' Minimum Shoulder Width N/A

Minimum Bridge Width N/A

Minimum Radius N/A Maximum Grade N/A

Minimum Taper Length N/A Minimum Intersection Level of Service N/A

Existing Traffic Queue Lengths N/A Projected Traffic Queue Lengths N/A

**Comments:**

\*2015

**KENTUCKY TRANSPORTATION CABINET  
 DEPARTMENT OF HIGHWAYS  
 TRAFFIC MANAGEMENT PLAN**

Item No. 5-9016.00

**Discussion:**

|  |            |   |            |
|--|------------|---|------------|
| <b>1) Public Information Plan</b>  |            |   |            |
| a) Prepare with assistance from <input checked="" type="checkbox"/> KYTC or <input type="checkbox"/> _____ |            |   |            |
| b) Identify Trip Generators  | N/A        | f) Railroad Involvement   | N/A        |
| c) Identify Types of Road Users  | Referenced | g) Address Pedestrians, Bikes<br>Mass Transit                   | Referenced |
| d) Public Information Message  | Referenced | h) Address Timing, Frequency, Updates,<br>Effectiveness of Plan | Referenced |
| e) Public Information Strategies<br>to be used   | Referenced | i) Police & Other<br>Emergency Services                         | Referenced |

**KENTUCKY TRANSPORTATION CABINET  
 DEPARTMENT OF HIGHWAYS  
 TRAFFIC MANAGEMENT PLAN**

Item No. 5-9016.00

| <b>2) Temporary Traffic Control Plan (For Each Phase of Construction)<br/>Phase I</b>   |                                     |
|---|-------------------------------------|
| <b>Exposure Control Measures</b>  | <b>Positive Protection Measures</b> |
| a) Is Road Closure Allowed<br>Type: *   | Referenced                          |
| a) Address Drop Off<br>Protection Criteria  | Referenced                          |
| b) Detour Conditions  | N/A                                 |
| b) Temporary Barrier Requirements   | Referenced                          |
| c) Working Hour Restrictions  | Referenced                          |
| c) Evaluation of Existing Guardrail<br>Conditions   | N/A                                 |
| d) Holiday or Special Event<br>Work Restrictions  | Referenced                          |
| d) Address Temporary Drainage   | N/A                                 |
| e) Evaluation of<br>Intersection LOS  | N/A                                 |
| <b>Uniformed Law Enforcement<br/>Officers</b>   | N/A                                 |
| f) Evaluation of Queue Lengths  | N/A                                 |
| <b>Payment for Traffic Control*</b>   |                                     |
| g) Evaluation of User Costs and<br>Incentives/Disincentives   | Referenced                          |
| a) Method of Project Bidding  | N/A                                 |
| h) Address Pedestrians, Bikes,<br>Mass Transit  | N/A                                 |
| b) Special Notes  | Referenced                          |
| <b>Work Vehicles and<br/>Equipment</b>  | N/A                                 |
| *Payment for traffic control items shall be in accordance with the Kentucky Department of Highways Standard Specifications for Road and Bridge Construction                           |                                     |
| Comments:   |                                     |
| * See attached Traffic Control Plan: Single Lane Closures & Shoulder Closure. Single lane closure allowed during hours of low traffic volume. One lane will remain open at all times. |                                     |

**KENTUCKY TRANSPORTATION CABINET  
 DEPARTMENT OF HIGHWAYS  
 TRAFFIC MANAGEMENT PLAN**

Item No. 5-9016.00

| <b>2) Temporary Traffic Control Plan (For Each Phase of Construction)<br/>Phase</b> |   |
|---|---|
| <b>Exposure Control Measures</b>  | <b>Positive Protection Measures</b>   |
| a) Is Road Closure Allowed      N/A<br>Type: **                                     | a) Address Drop Off Protection Criteria      N/A  |
| b) Detour Conditions      N/A   | b) Temporary Barrier Requirements      N/A  |
| c) Working Hour Restrictions      N/A   | c) Evaluation of Existing Guardrail Conditions      N/A   |
| d) Holiday or Special Event Work Restrictions      N/A                              | d) Address Temporary Drainage      N/A  |
| e) Evaluation of Intersection LOS      N/A  | <b>Uniformed Law Enforcement Officers</b> N/A   |
| f) Evaluation of Queue Lengths      N/A   | <b>Payment for Traffic Control*</b>   |
| g) Evaluation of User Costs and Incentives/Disincentives      N/A                   | a) Method of Project Bidding      N/A   |
| h) Address Pedestrians, Bikes, Mass Transit      N/A                                | b) Special Notes      N/A   |
| <b>Work Vehicles and Equipment</b> N/A  | *Payment for traffic control items shall be in accordance with the Kentucky Department of Highways Standard Specifications for Road and Bridge Construction |
| Comments:   |   |
|   |   |

**KENTUCKY TRANSPORTATION CABINET  
 DEPARTMENT OF HIGHWAYS  
 TRAFFIC MANAGEMENT PLAN**

Item No. 5-9016.00

| <b>2) Temporary Traffic Control Plan (For Each Phase of Construction)<br/>Phase</b> |   |
|---|---|
| <b>Exposure Control Measures</b>  | <b>Positive Protection Measures</b>   |
| a) Is Road Closure Allowed      N/A<br>Type: **                                     | a) Address Drop Off Protection Criteria      N/A  |
| b) Detour Conditions      N/A   | b) Temporary Barrier Requirements      N/A  |
| c) Working Hour Restrictions      N/A   | c) Evaluation of Existing Guardrail Conditions      N/A   |
| d) Holiday or Special Event Work Restrictions      N/A                              | d) Address Temporary Drainage      N/A  |
| e) Evaluation of Intersection LOS      N/A  | <b>Uniformed Law Enforcement Officers</b> N/A   |
| f) Evaluation of Queue Lengths      N/A   | <b>Payment for Traffic Control*</b>   |
| g) Evaluation of User Costs and Incentives/Disincentives      N/A                   | a) Method of Project Bidding      N/A   |
| h) Address Pedestrians, Bikes, Mass Transit      N/A                                | b) Special Notes      N/A   |
| <b>Work Vehicles and Equipment</b> N/A  | *Payment for traffic control items shall be in accordance with the Kentucky Department of Highways Standard Specifications for Road and Bridge Construction |
| Comments:   |   |
|   |   |

DEPARTMENT OF HIGHWAYS  
**TRAFFIC MANAGEMENT PLAN**  
Item No. 5-9016.00

**APPROVAL:**

  
\_\_\_\_\_  
Project Manager 10/2/2020  
Date

  
\_\_\_\_\_  
Project Delivery and Preservation Manager 10-22-20  
Date

  
\_\_\_\_\_  
Engineering Support Manager 10/16/20  
Date

\_\_\_\_\_  
FHWA Representative Date

**Revisions to the TMP require review/approval by the signatories.**

## TRAFFIC CONTROL PLAN

One lane of traffic will remain open during construction at all times on KY 864 (Fegenbush Lane). A single lane closure is anticipated on this route during construction during hours of low traffic volume. No lane closures are allowed between the hours of 6AM-8:30AM and 3:30PM-6PM Monday-Friday unless permission is otherwise granted by the engineer. A single lane closure will be allowed on the weekends (Saturday-Sunday) from 8:00AM-8:00PM. Fenwick Drive, between Fegenbush Lane and Mandeville Road, may be closed to allow local traffic only during working hours with neighborhood traffic utilizing Sherlock Way and Woodrow Way. All lane closures shall be in conformance with the current MUTCD & KYTC Standard Drawings.

In addition, lane closures will not be allowed during the following days:

|   |                          |
|---|--------------------------|
| January 17 <sup>th</sup> , 2022                 | MLK Day                  |
| April 16 <sup>th</sup> -17 <sup>th</sup> , 2022 | Easter Weekend           |
| TBD   | Thunder over Louisville  |
| May 28 <sup>th</sup> -30 <sup>th</sup> , 2022   | Memorial Day Weekend     |
| July 2 <sup>nd</sup> -4 <sup>th</sup> , 2022    | Independence Day Weekend |

At the discretion of the Engineer, additional days and hours may be added when lane closures will not be allowed.

Night work is not allowed on this project.

### **TRAFFIC CONTROL GENERAL:**

Except as provided herein, maintain and control traffic in accordance with the current Standard Specifications and Standard Drawings, current editions. Except for the roadway and traffic control bid items listed, all items of work necessary to maintain and control traffic will be paid at the lump sum bid price to "Maintain and Control Traffic."

Contrary to Section 106.01, traffic control devices used on this project may be new or used in like-new condition, at the beginning of work and maintained in like new condition until completion of the work.

The speed limit in the work area may be reduced by 10 MPH from the posted speed. The extent of these areas within the project limits will be restricted to the proximity of actual work areas as determined by the engineer.

Traffic control devices should follow the MUTCD and the standard drawings and must be approved by the engineer before placement. The shoulder work and lane encroachment will include signing present in MUTCD TA-6. Lane closure will include signing present in MUTCD TA-10. Signing is not limited to these guidelines and should be placed only with the approval from the engineer so as not to block sight distance. All lane and shoulder closures shall be in conformance with the current MUTCD & KYTC Standard Drawings. The minimum clear lane width shall be **10 ft** (this may include a portion of the

adjacent shoulder.) If traffic should be stopped due to construction operations and a school bus or emergency vehicle on an official run arrives on the scene, make provisions for the passage of the bus as quickly as possible.

At the discretion of the engineer, additional days and hours may be specified when lane closures will not be allowed. A minimum of one lane of traffic on KY 864 is to be maintained at all times throughout construction.

Once work begins at a site, promptly complete all work at that site. Maintain at least one access point to each parcel at all times. Keep the traveled way and adjacent sidewalks clear of mud and debris at all times during construction. Do not allow non-construction equipment, vehicles, or office trailers at work sites. Leave the right of way clear of all equipment, materials, and vehicles during non-working hours.

Take these restrictions into account when preparing bid. The Department will not consider any claims or allow additional payment for any delays to the Contractor as a result of these restrictions.

#### **PROJECT PHASING AND CONSTRUCTION PROCEDURES:**

No lane closures will be allowed between the hours of **6AM – 8:30AM** and **3:30PM – 6PM (Monday through Friday)**.

#### **PROJECT DISCRETION:**

Refer to Section 108.09 of the current edition of the KENTUCKY STANDARD SPECIFICATIONS FOR ROAD CONSTRUCTION for the schedule of agreed liquidated damages should construction continue beyond the specified completion date.

#### **LANE CLOSURES:**

Do not leave lane closures in place during non-working hours.

#### **SIGNS:**

The engineer may require additional traffic control signs in addition to normal lane closure signing detailed on the Standard Drawings.

Replacements for damaged signs directed by the engineer to be replaced due to poor condition or reflectivity will not be measured for payment.

#### **TRAFFIC COORDINATOR:**

Designate an employee to be traffic coordinator during any work period when shoulder and/or lane closure is in place, the traffic coordinator shall arrange for personnel to be present on the project at all times to inspect the traffic control (at least once every two hours during active operations and at any time a lane closure is in effect) and to maintain the signing and devices. The personnel shall have access to on the project to a radio or telephone to be used in case of emergencies or accidents. The traffic coordinator shall report all incidents throughout the work zone to the engineer. Furnish the engineer with the name and telephone number where the traffic coordinator can be contacted at all

times.

**ARROW PANEL**

Use of arrow panels as shown on the Standard Drawings, current addition, or as directed by the Engineer. The Department will measure payment for arrow panels as incidental to the maintain and control traffic bid item. Replacements for damaged arrow panels as directed by the engineer will not be measured for payment.

October 2021

**SPECIAL NOTE FOR NON-TRACKING TACK COAT**

1. DESCRIPTION AND USEAGE. This specification covers the requirements and practices for applying a non-tracking tack asphalt coating. Place this material on the existing pavement course, prior to placement of a new asphalt pavement layer. Use when expedited paving is necessary or when asphalt tracking would negatively impact the surrounding area. This material is not suitable for other uses. Ensure material can “break” within 15 minutes under conditions listed in 3.2.

2. MATERIALS, EQUIPMENT, AND PERSONNEL.

2.1 Non-Tracking Tack. Provide material conforming to Subsection 2.1.1.

2.1.1 Provide a tack conforming to the following material requirements:

| Property                                  | Specification | Test Procedure |
|---|---------------|----------------|
| Viscosity, SFS, 77 ° F                    | 20 – 100      | AASHTO T 72    |
| Sieve, %                                  | 0.3 max.      | AASHTO T 59    |
| Asphalt Residue <sup>1</sup> , %          | 50 min.       | AASHTO T 59    |
| Oil Distillate, %                         | 1.0 max.      | AASHTO T 59    |
| Residue Penetration, 77 ° F               | 20 max.       | AASHTO T 49    |
| Original Dynamic Shear (G*/sin δ), 82 ° C | 1.0 min.      | AASHTO T 315   |
| Softening Point, ° F                      | 149 min.      | AASHTO T 53    |
| Solubility, %                             | 97.5 min.     | AASHTO T 44    |

<sup>1</sup> Bring sample to 212 °F over a 10-15 minute period. Maintain 212 °F for 15-20 minutes or until 30-40 mL of water has distilled. Continue distillation as specified in T59.

2.2. Equipment. Provide a distributor truck capable of heating, circulating, and spraying the tack between 170 °F and 180 °F. Do not exceed 180 °F. Circulate the material while heating. Provide the correct nozzles that is recommend by the producer to ensure proper coverage of tack is obtained. Ensure the bar can be raised to between 14” and 18” from the roadway.

2.3. Personnel. Ensure the tack supplier has provided training to the contractor on the installation procedures for this product. Make a technical representative from the supplier available at the request of the Engineer.

3. CONSTRUCTION.

3.1 Surface Preparation. Prior to the application of the non-tracking tack, ensure the pavement surface is thoroughly dry and free from dust or any other debris that would inhibit adhesion. Clean the surface by scraping, sweeping, and the use of compressed air. Ensure this preparation process occurs shortly before application to prevent the return of debris on to the pavement. If rain is expected within one hour after application, do not apply material. Apply material only when the surface is dry, and no precipitation is expected.

October 2021

- 3.2 Non-tracking Tack Application. Placement of non-tracking tack is not permitted from October 1<sup>st</sup> to May 15<sup>th</sup>. When applying material, ensure the roadway temperature is a minimum of 40°F and rising. Prior to application, demonstrate competence in applying the tack according to this note to the satisfaction of the Engineer. Heat the tack in the distributor to between 170 – 180 °F. After the initial heating, between 170 – 180 °F, the material may be sprayed between 165 °F and 180 °F. Do not apply outside this temperature range. Apply material at a minimum rate of 0.70 pounds (0.08 gallons) per square yard. Ensure full coverage of the material on the pavement surface. Full coverage of this material is critical. Increase material application rate if needed to achieve full coverage. Schedule the work so that, at the end of the day's production, all non-tracking tack is covered with the asphalt mixture. If for some reason the non-tracking tack cannot be covered by an asphalt mixture, ensure the non-tracking tack material is clean and reapply the non-tracking tack prior to placing the asphalt mixture. Do not heat material more than twice in one day.
- 3.3 Non-tracking Tack Certification. Furnish the tack certification to the Engineer stating the material conforms to all requirements herein prior to use.
- 3.4 Sampling and Testing. The Department will require a sample of non-tracking tack be taken from the distributor at a rate of one sample per 15,000 tons of mix. Take two 1 gallon samples of the heated material and forward the sample to the Division of Materials for testing within 7 days. Ensure the product temperature is between 170 and 180 °F at the time of sampling.
4. MEASUREMENT. The Department will measure the quantity of non-tracking tack in tons. The Department will not measure for payment any extra materials, labor, methods, equipment, or construction techniques used to satisfy the requirements of this note. The Department will not measure for payment any trial applications of non-tracking tack, the cleaning of the pavement surface, or furnishing and placing the non-tracking tack. The Department will consider all such items incidental to the non-tracking tack.
5. PAYMENT. The Department will pay for the non-tracking tack at the Contract unit bid price and apply an adjustment for each manufacturer's lot of material based on the degree of compliance as defined in the following schedule. Non-tracking tack will not be permitted for use from October 1<sup>st</sup> to May 15<sup>th</sup>. From September 1<sup>st</sup> to June 1<sup>st</sup>, the department will allow the use of an approved asphalt emulsion in lieu of a non-tracking tack product but will not adjust the unit bid price of the material. When a sample fails on two or more tests, the Department may add the deductions, but the total deduction will not exceed 100 percent.

October 2021

| Non-Tracking Tack Price Adjustment Schedule |               |          |             |             |             |        |
|---|---------------|----------|-------------|-------------|-------------|--------|
| Test  | Specification | 100% Pay | 90% Pay     | 80% Pay     | 50% Pay     | 0% Pay |
| Viscosity, SFS, 77 ° F                      | 20 – 100      | 19 - 102 | 17 - 18     | 15 - 16     | 14          | ≤13    |
|   |               |          | 103 - 105   | 106 - 107   | 108 - 109   | ≥ 110  |
| Sieve, %                                    | 0.30 max.     | ≤ 0.40   | 0.41 - 0.50 | 0.51 - 0.60 | 0.61 - 0.70 | ≥ 0.71 |
| Asphalt Residue, %                          | 50 min.       | ≥49.0    | 48.5 – 48.9 | 48.0 – 48.4 | 47.5-47.9   | ≤ 47.4 |
| Oil Distillate, %                           | 1.0 max.      | ≤1.0     | 1.1-1.5     | 1.6 - 1.7   | 1.8-1.9     | >2.0   |
| Residue Penetration, 77 ° F                 | 20 max.       | ≤ 21     | 22 - 23     | 24 - 25     | 26 - 27     | ≥ 28   |
| Original Dynamic Shear (G*/sin δ), 82 ° C   | 1.0 min.      | ≥0.95    | 0.92 – 0.94 | 0.90 – 0.91 | 0.85 - 0.89 | ≤ 0.84 |
| Softening Point, ° F                        | 149 min.      | ≥145     | 142 - 144   | 140 - 141   | 138 - 139   | ≤ 137  |
| Solubility, %                               | 97.5 min.     | ≥ 97.0   | 96.8 – 96.9 | 96.6 – 96.7 | 96.4 – 96.5 | ≤ 96.3 |

| <u>Code</u> | <u>Pay Item</u>                        | <u>Pay Unit</u> |
|-------------|--|-----------------|
| 24970EC     | Asphalt Material for Tack Non-Tracking | Ton             |

|   |   |  |
|---|---|--|
|  | KENTUCKY TRANSPORTATION CABINET<br>Department of Highways<br>DIVISION OF RIGHT OF WAY & UTILITIES | TC 62-226<br>Rev. 01/2016<br>Page 1 of 1 |
| <b>RIGHT OF WAY CERTIFICATION</b>   |   |  |

|   |  |                                   |                            |
|---|--|-----------------------------------|----------------------------|
| <input checked="" type="checkbox"/> <b>Original</b> | <input type="checkbox"/> <b>Re-Certification</b> | <b>RIGHT OF WAY CERTIFICATION</b> |                            |
| <b>ITEM #</b>                                       | <b>COUNTY</b>                                    | <b>PROJECT # (STATE)</b>          | <b>PROJECT # (FEDERAL)</b> |
| 5-9016.00   | Jefferson  | FD52 056 0864 005-007             | HSIP 8744 005              |

**PROJECT DESCRIPTION**

Widen KY 864 to create a northbound left turn lane between mile points 5.950 and 6.20

**No Additional Right of Way Required**

Construction will be within the limits of the existing right of way. The right of way was acquired in accordance to FHWA regulations under the Uniform Relocation Assistance and Real Property Acquisitions Policy Act of 1970, as amended. No additional right of way or relocation assistance were required for this project.

**Condition # 1 (Additional Right of Way Required and Cleared)**

All necessary right of way, including control of access rights when applicable, have been acquired including legal and physical possession. Trial or appeal of cases may be pending in court but legal possession has been obtained. There may be some improvements remaining on the right-of-way, but all occupants have vacated the lands and improvements, and KYTC has physical possession and the rights to remove, salvage, or demolish all improvements and enter on all land. Just Compensation has been paid or deposited with the court. All relocations have been relocated to decent, safe, and sanitary housing or that KYTC has made available to displaced persons adequate replacement housing in accordance with the provisions of the current FHWA directive.

**Condition # 2 (Additional Right of Way Required with Exception)**

The right of way has not been fully acquired, the right to occupy and to use all rights-of-way required for the proper execution of the project has been acquired. Some parcels may be pending in court and on other parcels full legal possession has not been obtained, but right of entry has been obtained, the occupants of all lands and improvements have vacated, and KYTC has physical possession and right to remove, salvage, or demolish all improvements. Just Compensation has been paid or deposited with the court for most parcels. Just Compensation for all pending parcels will be paid or deposited with the court prior to AWARD of construction contract

**Condition # 3 (Additional Right of Way Required with Exception)**

The acquisition or right of occupancy and use of a few remaining parcels are not complete and/or some parcels still have occupants. All remaining occupants have had replacement housing made available to them in accordance with 49 CFR 24.204. KYTC is hereby requesting authorization to advertise this project for bids and to proceed with bid letting even though the necessary right of way will not be fully acquired, and/or some occupants will not be relocated, and/or the just compensation will not be paid or deposited with the court for some parcels until after bid letting. KYTC will fully meet all the requirements outlined in 23 CFR 635.309(c)(3) and 49 CFR 24.102(j) and will expedite completion of all acquisitions, relocations, and full payments after bid letting and prior to AWARD of the construction contract or force account construction.

| Total Number of Parcels on Project               | EXCEPTION (S) Parcel # | ANTICIPATED DATE OF POSSESSION WITH EXPLANATION |
|--|------------------------|---|
| <b>Number of Parcels That Have Been Acquired</b> |                        |   |
| Signed Deed                                      |                        |   |
| Condemnation                                     |                        |   |
| Signed ROE                                       |                        |   |

**Notes/ Comments (Use Additional Sheet if necessary)**

|                               |  |                                |   |
|-------------------------------|--|--------------------------------|---|
| <b>LPA RW Project Manager</b> |  | <b>Right of Way Supervisor</b> |   |
| Printed Name                  |  | Printed Name                   | Tom Boykin  |
| Signature                     |  | Signature                      | Tom Boykin<br><small>Digitally signed by Tom Boykin<br/>Date: 2020.10.19 20:31:46 -0400</small> |
| Date                          |  | Date                           |   |
| <b>Right of Way Director</b>  |  | <b>FHWA</b>                    |   |
| Printed Name                  |  | Printed Name                   | <b>No Signature Required<br/>as per FHWA-KYTC</b>   |
| Signature                     |  2020.10.20 | Signature                      | <b>Current Stewardship Agreement</b>  |
| Date                          | 07:44:44 -05'00'   | Date                           |   |

## UTILITIES AND RAIL CERTIFICATION NOTE

**Jefferson County**  
**OHSIP8744005**  
**FD52 056 9470101U**  
**Mile point: 5.950 TO 6.200**  
**WIDEN KY 864 TO CREATE A NORTHBOUND LEFT TURN LANE. (2018BOP)**  
**ITEM NUMBER: 05-9016.00**

### PROJECT NOTES ON UTILITIES

Please Note: The information presented in this Utility Note is informational in nature and the information contained herein is not guaranteed.

The contractor will be responsible for contacting all utility facility owners on the subject project to coordinate his activities. The contractor will coordinate his activities to minimize and, where possible, avoid conflicts with utility facilities. Due to the nature of the work proposed, it is unlikely to conflict with the existing utilities beyond minor facility adjustments. Where conflicts with utility facilities are unavoidable, the contractor will coordinate any necessary relocation work with the facility owner and Resident Engineer. The Kentucky Transportation Cabinet maintains the right to remove or alter portions of this contract if a utility conflict occurs. The utility facilities as noted in the previous section(s) have been determined using data garnered by varied means and with varying degrees of accuracy: from the facility owners, a result of S.U.E., field inspections, and/or reviews of record drawings. The facilities defined may not be inclusive of all utilities in the project scope and are not Level A quality, unless specified as such. It is the contractor's responsibility to verify all utilities and their respective locations before excavating.

The contractor shall make every effort to protect underground facilities from damage as prescribed in the Underground Facility Damage Protection Act of 1994, Kentucky Revised Statute KRS 367.4901 to 367.4917. It is the contractor's responsibility to determine and take steps necessary to be in compliance with federal and state damage prevention directives. The contractor is instructed to contact KY 811 for the location of existing underground utilities. Contact shall be made a minimum of two (2) and no more than ten (10) business days prior to excavation.

The contractor shall submit Excavation Locate Requests to the Kentucky Contact Center (KY 811) via web ticket entry. The submission of this request does not relieve the contractor from the responsibility of contacting non-member facility owners, whom are to be contacted through their individual Protection Notification Center. It may be necessary for the contractor to contact the County Court Clerk to determine what utility companies have facilities in the area. Non-compliance with these directives can result in the enforcement of penalties.

## UTILITIES AND RAIL CERTIFICATION NOTE

Jefferson County  
 OHSIP8744005  
 FD52 056 9470101U  
 Mile point: 5.950 TO 6.200  
**WIDEN KY 864 TO CREATE A NORTHBOUND LEFT TURN LANE. (2018BOP)**  
 ITEM NUMBER: 05-9016.00

**NOTE: DO NOT DISTURB THE FOLLOWING FACILITIES LOCATED WITHIN THE PROJECT DISTURB LIMITS**

AT&T Kentucky - Communications– The Company has aerial communication lines on the LG&E owned pole route better described below. The Company has an underground communication line located south/west of and running parallel to Fegenbush Lane (KY 864) on the opposite side of the roadside ditch and crosses Fenwick Drive before exiting the Project limits at ~STA. 27+10 50' LT.

Charter Communications (Insight/Spectrum/Time Warner) - Communications The Company has aerial communication lines on the LG&E owned pole route better described below. The Company also has underground communication lines feeding Shallow Creek from the existing pole at the entrance to Fenwick Drive.

Louisville Gas and Electric Company – Electric - The Company has an existing aerial distribution pole route on the north/east side of KY 864 from the beginning of the project until STA. 26+50 where it crosses KY 864 and continues on the west side of the roadway. Also located at STA. 26+50 is a crossing serving Shallow Creek neighborhood.

Louisville Gas and Electric Company – Gas - See below for gas.

Louisville Water Company – Water – See below.

Verizon – Communications - The Company has aerial communication lines on the LG&E owned pole route better described above.

**\*The Contractor is fully responsible for protection of all utilities listed above\***

**THE FOLLOWING FACILITY OWNERS ARE RELOCATING/ADJUSTING THEIR FACILITIES WITHIN THE PROJECT LIMITS AND WILL BE COMPLETE PRIOR TO CONSTRUCTION**

LG&E – Gas – The Company has 4” M.P. PL gas main that is located south/west of and running parallel to Fegenbush Lane (KY 864). The Company has relocated the existing gas main from approximately STA. 22+35 to STA. 27+30 and is located 25’-35’ LT of KY 864 centerline. There are 5 property service connections within the project limits including a 2” M.P. crossing at STA. 23+65. The Company has 500 LF of an abandoned 4” M.P. under the proposed pavement widening.

**THE FOLLOWING FACILITY OWNERS HAVE FACILITIES TO BE RELOCATED/ADJUSTED BY THE OWNER OR THEIR SUBCONTRACTOR AND IS TO BE COORDINATED WITH THE ROAD CONTRACT**

Not Applicable

## UTILITIES AND RAIL CERTIFICATION NOTE

Jefferson County  
 OHSIP8744005  
 FD52 056 9470101U  
 Mile point: 5.950 TO 6.200  
**WIDEN KY 864 TO CREATE A NORTHBOUND LEFT TURN LANE. (2018BOP)**  
 ITEM NUMBER: 05-9016.00

**THE FOLLOWING FACILITY OWNERS HAVE FACILITIES TO BE RELOCATED/ADJUSTED BY THE ROAD CONTRACTOR AS INCLUDED IN THIS CONTRACT**

Louisville Water Company – Water – The Company has an existing 12” CLD water main (WM) that is located south/west of and running parallel to Fegenbush Lane (KY 864). The existing 12” CLD WM is to be relocated by the roadway contractor from ~STA. 22+24 to ~STA. 27+80. The Roadway Contractor will tie-in the 12” DPW WM to an existing 8” DI WM located under the east lane of Fenwick Drive at ~STA. 26+60.

**RAIL COMPANIES HAVE FACILITIES IN CONJUNCTION WITH THIS PROJECT AS NOTED**

No Rail Involvement     Rail Involved     Rail Adjacent

### AREA FACILITY OWNER CONTACT LIST

- |  |   |
|--|---|
| <p>1. AT&amp;T KY<br/>       1340 E. John Rowan Blvd<br/>       Bardstown, KY 40004</p>  | <p>Scott Roche<br/>       Office (502) 348-4528<br/>       Cell (502) 827-4703<br/> <a href="mailto:SR8832@att.com">SR8832@att.com</a></p>  |
| <p>2. Charter Communications<br/>       10168 Linn Station Road, Suite 120<br/>       Louisville, KY 40223</p>   | <p>Nathen L Howerton<br/>       Office (502) 357-4318<br/>       Cell (502) 639-6838<br/> <a href="mailto:Nathen.Howerton@charter.com">Nathen.Howerton@charter.com</a><br/>       James Whitehouse<br/>       (502) 643-0863<br/> <a href="mailto:James.Whitehouse@charter.com">James.Whitehouse@charter.com</a><br/>       Kevin Mercer<br/>       Office (502) 357-4724<br/>       Cell (502) 817-5055<br/> <a href="mailto:Kevin.Mercer@charter.com">Kevin.Mercer@charter.com</a><br/>       Michael York<br/>       Cell (502) 548-1632<br/> <a href="mailto:Michael.York@charter.com">Michael.York@charter.com</a><br/>       Richard Bast<br/>       Office (502) 357-4118<br/>       Cell (502) 817-0734</p> |
| <p>3. LG&amp;E KU (Electric)<br/>       820 West Broadway<br/>       Louisville, KY 40202<br/>       LG&amp;E Emergency Number (502) 589-1444<br/>       LG&amp;E and KU Emergency Number 1-800-331-7370</p> | <p>Caroline Justice<br/>       Office: (502) 627-3708<br/> <a href="mailto:Caroline.Justice@LGE-KU.com">Caroline.Justice@LGE-KU.com</a></p>   |

## UTILITIES AND RAIL CERTIFICATION NOTE

Jefferson County  
OHSIP8744005  
FD52 056 9470101U  
Mile point: 5.950 TO 6.200  
**WIDEN KY 864 TO CREATE A NORTHBOUND LEFT TURN LANE. (2018BOP)**  
ITEM NUMBER: 05-9016.00

- |  |   |
|--|---|
| 4. LG&E (Gas)<br>820 West Broadway<br>Louisville, KY 40202<br>Gas Emergency Number (502) 589-5511<br>LG&E and KU Emergency Number 1-800-331-7370 | Caroline Justice<br>Office: (502) 627-3708<br><a href="mailto:Caroline.Justice@LGE-KU.com">Caroline.Justice@LGE-KU.com</a>  |
| 5. Louisville Water Company<br>550 South Third Street<br>Louisville, KY 40202  | Daniel Tegene, PE<br>(502) 569-3649<br><a href="mailto:DTegene@LWCky.com">DTegene@LWCky.com</a>   |
| 6. Metropolitan Sewer District<br>700 West Liberty Street<br>Louisville, KY 40203-1911   | Brandon Flaherty<br>Office (502) 540-6632<br>Cell (502) 381-0804<br><a href="mailto:Brandon.Flaherty@LouisvilleMSD.org">Brandon.Flaherty@LouisvilleMSD.org</a><br>Greg Powell<br><a href="mailto:Greg.Powell@LouisvilleMSD.org">Greg.Powell@LouisvilleMSD.org</a>   |
| 7. Verizon<br>730 West Henry Street<br>Indianapolis, IN 46225<br><br>Verizon<br>2421 Holloway Road<br>Louisville, KY 40299                       | Dean Boyers<br>Office (615) 777-7855<br>Cell (615) 507-5287<br><a href="mailto:Dean.Boyers@verizon.com">Dean.Boyers@verizon.com</a><br>Jeffrey Tucker, Engr III Spec-Ntwk Eng & Ops<br>Office (502) 830-1827<br>Cell (502) 593-5585<br><a href="mailto:Jeffrey.Tucker@verizon.com">Jeffrey.Tucker@verizon.com</a><br>Ronnie Kuerzi, Eng IV Spec-Ntwk Eng & Ops<br>Cell (502) 780-2748<br><a href="mailto:Ronald.Kuerzi@verizon.com">Ronald.Kuerzi@verizon.com</a><br>Dave Wiley (Field)<br>(502) 439-8783<br><a href="mailto:Dave.Wiley@verizon.com">Dave.Wiley@verizon.com</a><br>John Binkley, <a href="mailto:John.Binkley@tcscomm.com">John.Binkley@tcscomm.com</a><br>Mike Escollies, <a href="mailto:MEscollies@tcscomm.com">MEscollies@tcscomm.com</a> |

# **GENERAL UTILITY NOTES AND INSTRUCTIONS APPLICABLE TO ALL UTILITY WORK MADE A PART OF THE ROAD CONSTRUCTION CONTRACT**

**The contractor should be aware the following utility notes and KYTC Utility Bid Item Descriptions shall supersede, replace and take precedence over any and all conflicting information that may be contained in utility owner supplied specifications contained in the contract, on plans supplied by the utility owner, or any utility owner specifications or information externally referenced in this contract.**

**Where information may have been omitted from these notes, bid item descriptions, utility owner supplied specifications or plans; the KYTC Standard Specifications for Road and Bridge Construction shall be referenced.**

## **PROTECTION OF EXISTING UTILITIES**

The existing utilities shown on the plans are shown as best known at the time the plans were developed and are to be used as a guide only by the Contractor. The Contractor shall use all means at his disposal to accurately locate all existing utilities, whether shown on the plans or not, prior to excavation. The contractor shall protect these utilities during construction. Any damage to existing utilities during construction that are shown or not shown on the plans shall be repaired at the Contractor's expense.

## **PREQUALIFIED UTILITY CONTRACTORS**

Some utility owners may require contractors that perform relocation work on their respective facilities as a part of the road contract be prequalified or preapproved by the utility owner. Those utility owners with a prequalification or preapproval requirement are as follows:

Louisville Water Company

The bidding contractor needs to choose a subcontractor who is a Louisville Water Company prequalified contractor in the category of 4-16 inch ductile iron water main.

The bidding contractor needs to review the above list and choose from the list of approved subcontractors at the end of these general notes as identified above before bidding. When the list of approved subcontractors is provided, only subcontractors shown on the following list(s) will be allowed to work on that utility as a part of this contract.

When the list of approved subcontractors for the utility work is not provided in these general notes, the utility work can be completed by the prime contractor. If the prime contractor chooses to subcontract the work, the subcontractor shall be prequalified with the KYTC Division of Construction Procurement in the work type of "Utilities" (I33). Those who would like to become prequalified may contact the Division of Construction Procurement at (502) 564-3500. Please note: it could take up to 30 calendar days for prequalification to be approved. The prequalification does not have to be approved prior to the bid, but must be approved before the subcontract will be approved by KYTC and the work can be performed.

#### CONTRACT ADMINISTRATION RELATIVE TO UTILITY WORK

All utility work is being performed as a part of a contract administered by KYTC; there is not a direct contract between the utility contractor and utility owner. The KYTC Section Engineer is ultimately responsible for the administration of the road contract and any utility work included in the contract.

#### SUBMITTALS AND CORRESPONDENCE

All submittals and correspondence of any kind relative to utility work included in the road contract shall be directed to the KYTC Section Engineer, a copy of which may also be supplied to the utility owner by the contractor to expedite handling of items like material approvals and shop drawings. All approvals and correspondence generated by the utility owner shall be directed to the KYTC Section Engineer. The KYTC Section Engineer will relay any approvals or correspondence to the utility contractor as appropriate. At no time shall any direct communication between the utility owner and utility contractor without the communication flowing through the KYTC Section Engineer be considered official and binding under the contract.

#### ENGINEER

Where the word "Engineer" appears in any utility owner specifications included in this proposal, utility owner specifications included as a part of this contract by reference or on the utility relocation plans, it shall be understood the "Engineer" is the Kentucky Transportation Cabinet (KYTC) Section Engineer or designated representative and the utility owner engineer or designated representative jointly. Both engineers must mutually agree upon all decisions made with regard to the utility construction. The Transportation Cabinet, Section Engineer shall make all final decisions in all disputes.

#### STANDARD SPECIFICATIONS

The Contractor shall follow the Louisville Water Company *TECHNICAL SPECIFICATIONS AND STANDARD DRAWINGS FOR PIPELINE CONSTRUCTION 2008*. All work shall be performed in accordance with accepted workmanship practices and the Technical Specifications and Standard Drawings.

[https://www.louisvillewater.com/sites/louisvillewater.com/files/user\\_uploads/Procurement%20Other/2008%20TECHNICAL%20SPECIFICATIONS%20FOR%20PIPELINE%20CONSTRUCTION%20%28Final%20Complete%203-10-2008%20Print%20PDF%29.pdf](https://www.louisvillewater.com/sites/louisvillewater.com/files/user_uploads/Procurement%20Other/2008%20TECHNICAL%20SPECIFICATIONS%20FOR%20PIPELINE%20CONSTRUCTION%20%28Final%20Complete%203-10-2008%20Print%20PDF%29.pdf)

### INSPECTOR OR RESIDENT PROJECT REPRESENTATIVE

Where the word “Inspector” or “Resident Project Representative” appears in the utility specifications included in this proposal, utility owner specifications included as a part of this contract by reference or on the utility relocation plans, it shall be understood the “Inspector” or “Resident Project Representative” is the utility owner inspector and KYTC inspector jointly. The Transportation Cabinet, Section Engineer shall make all final decisions in all disputes.

### NOTICE TO UTILITY OWNERS OF THE START OF WORK

One month before construction is to start on a utility, the utility contractor shall make notice to the KYTC Section Engineer and the utility owner of when work on a utility is anticipated to start. The utility contractor shall again make confirmation notice to the KYTC Section Engineer and the utility owner one week before utility work is to actually start.

### UTILITY SHUTDOWNS

The Contractor shall not shut down any active and in-service mains, utility lines or services for any reason unless specifically given permission to do so by the utility owner. The opening and closing of valves and operating of other active utility facilities for main, utility line or utility service shut downs are to be performed by the utility owner unless specific permission is given to the contractor by the owner to make shutdowns. If and when the utility owner gives the contractor permission to shutdown mains, utility lines or utility services, the contractor shall do so following the rules, procedures and regulations of the utility owner. Any permission given by the utility owner to the contractor to shutdown active and in-service mains, utility lines or services shall be communicated to the KYTC Section Engineer by the utility owner that such permission has been given.

Notice to customers of utility shut downs is sometimes required to be performed by the utility contractor. The contractor may be required; but, is not limited to, making notice to utility customers in a certain minimum amount of time in advance of the shut down and by whatever means of communication specified by the utility owner. The means of communication to the customer may be; but is not limited to, a door hanger, notice by newspaper ad, telephone contact, or any combination of communication methods deemed necessary, customary and appropriate by the utility owner. The contractor should refer to the utility owner specifications for requirements on customer notice.

Any procedure the utility owner may require the contractor to perform by specification or plan note and any expense the contractor may incur to comply with the utility owner’s shut down procedure and notice to customers shall be considered an incidental expense to the utility construction.

CUSTOMER SERVICE AND LATERAL ABANDONMENTS When temporary or permanent abandonment of customer water, gas, or sewer services or laterals are necessary during relocation of utilities included in the contract, the utility contractor shall perform these abandonments as part of the contract as incidental work. No separate payment will be made for service line and lateral abandonments. The contractor shall provide all labor, equipment and materials to accomplish the temporary or permanent abandonment in accordance with the plans, specifications and/or as directed by the engineer. Abandonment may include, but is not limited to, digging down on a water or gas main at the tap to turn off the tap valve

or corporation stop and/or capping or plugging the tap, digging down on a sewer tap at the main and plugging or capping the tap, digging down on a service line or lateral at a location shown on the plans or agreeable to the engineer and capping or plugging, or performing any other work necessary to abandon the service or lateral to satisfactorily accomplish the final utility relocation.

### STATIONS AND DISTANCES

All stations and distances, when indicated for utility placement in utility relocation plans or specifications, are approximate; therefore, some minor adjustment may have to be made during construction to fit actual field conditions. Any changes in excess of 6 inches of plan location shall be reviewed and approved jointly by the KYTC Section Engineer or designated representative and utility owner engineer or designated representative. Changes in location without prior approval shall be remedied by the contractor at his own expense if the unauthorized change creates an unacceptable conflict or condition.

### RESTORATION

Temporary and permanent restoration of paved or stone areas due to utility construction shall be considered incidental to the utility work. No separate payment will be made for this work. Temporary restoration shall be as directed by the KYTC Section Engineer. Permanent restoration shall be "in-kind" as existing.

Restoration of seed and sod areas will be measured and paid under the appropriate seeding and sodding bid items established in the contract for roadway work.

---

BELOW ARE NOTES FOR WHEN "INST" ITEMS ARE IN THE CONTRACT MEANING THE UTILITY COMPANY IS PROVIDING CERTAIN MATERIALS FOR UTILITY RELOCATION

### MATERIAL

Contrary to Utility Bid Item Descriptions, those bid items that have the text "**Inst**" at the end of the bid item will have the major components of the bid item provided by the utility owner. No direct payment will be made for the major material component(s) supplied by the utility company. All remaining materials required to construct the bid item as detailed in utility bid item descriptions, in utility specifications and utility plans that are made a part of this contract will be supplied by the contractor. The contractor's bid price should reflect the difference in cost due to the provided materials.

The following utility owners have elected to provide the following materials for work under this contract:

***"No materials are being supplied by the utility owner(s). All materials are to be supplied by the contractor per bid item descriptions, utility specifications and utility plans."***

### SECURITY OF SUPPLIED MATERIALS

If any utility materials are to be supplied by the utility owner, it will be the responsibility of the utility contractor to secure all utility owner supplied materials after delivery to the project site. The utility

contractor shall coordinate directly with the utility owner and their suppliers for delivery and security of the supplied materials. Any materials supplied by the utility owner and delivered to the construction site that are subsequently stolen, damaged or vandalized and deemed unusable shall be replaced with like materials at the contractor's expense.

# Standard Water Bid Item Descriptions

**W AIR RELEASE VALVE** This bid item description shall apply to all air release valve installations of every size except those defined as “Special”. This item shall include the air release valve, main to valve connecting line or piping, manhole, vault, structure, access casting or doors, tapping the main, labor, equipment, excavation, proper backfill and restoration required to install the air release valve at the location shown on the plans or as directed in accordance with the specifications and standard drawings complete and ready for use. All air release/vacuum valves on a project shall be paid under one bid item regardless of size. No separate pay items will be established for size variations. Only in the case of the uniqueness of a particular air release valve would a separate bid item be established. Please refer to the Utility Company’s Specifications. If the Company does not have specifications, KYTC’s Specifications shall be referenced. This item shall be paid EACH (EA) when complete.

**BOLLARDS** This item is for payment for furnishing and installing protective guard posts at above ground utility installations. A bollard may consist of, but not limited to, a steel post set in concrete or any other substantial post material. This item shall include all labor, equipment, and materials needed for complete installation of the bollard as specified by the utility owner specifications and plans. If the Company does not have specifications, KYTC’s Specifications shall be referenced. This item shall be paid EACH (EA) when complete.

*NOTE: A bid code for this item has been established in standard roadway bid items and shall be used for payment of this item. The bid code is 21341ND*

**W CAP EXISTING MAIN** This item shall include the specified cap, concrete blocking and/or mechanical anchoring, labor, equipment, excavation, backfill, and restoration required to install the cap at the location shown on the plans or as directed in accordance with the specifications. This item is not to be paid on new main installations. This pay item is only to be paid to cap existing mains. Caps on new mains are incidental to the new main. Any and all caps on existing mains shall be paid under one bid item included in the contract regardless of size. No separate bid items will be established for size variations. Please refer to the Utility Company’s Specifications. If the Company does not have specifications, KYTC’s Specifications shall be referenced. This item shall be paid EACH (EA) when complete.

**W DIRECTIONAL BORE** Payment under this item is made whenever the plans or specifications specifically show directional boring is to be utilized in order to minimize the impact of open cut for the installation of water main under streets, creeks, and etc. Payment under this item shall include the specified bore pipe, labor, and equipment. No separate payment shall be made for bore pipe installed in the bore whether used as a carrier pipe or an encasement of a separate carrier pipe. This item shall also include pipe anchors at each end of the bore when specified to prevent the creep or contraction of the bore pipe. Carrier pipe installed within a bore pipe shall be paid separately under pipe items. Payment under this item shall not be size specific and no separate bid items will be established for size variations. The bore pipe sizes to be included under this item shall be as shown on the plans and/or in the specifications. Any and all directional bores in each contract shall be paid under one directional bore bid item included in the contract regardless of size. Please refer to the Utility Company’s Specifications. If the Company does not have specifications, KYTC’s Specifications shall be referenced. This item shall be paid LINEAR FEET (LF) when complete.

**W ENCASUREMENT CONCRETE** Includes all labor, equipment, excavation, concrete, reinforcing steel, backfill, restoration, and etc., to construct the concrete encasement of the water main as shown on the plans, and in accordance with the specifications and standard drawings. Payment under this item shall be in addition to the carrier pipe as paid under separate bid items. Carrier pipe is not included in this bid item. Any and all concrete encasement shall be paid under one bid item included in the contract regardless of the size of the carrier pipe or the volume of concrete or steel reinforcement as specified in the plans and specifications. No separate bid items will be established for size variations. Measurement of pay quantity shall be from end of concrete to end of concrete. Please refer to the Utility Company's Specifications. If the Company does not have specifications, KYTC's Specifications shall be referenced. This item shall be paid LINEAR FEET (LF) when complete.

**W ENCASUREMENT STEEL BORED** This item shall include the steel encasement pipe size as specified on the plans and in the specifications, casing spacers, end seals, labor, and equipment to bore and install the encasement in accordance with the plans and specifications, complete and ready for use. The size shall be the measured internal diameter of the encasement pipe. The sizes of encasement to be paid under the size ranges specified in the bid items shall be as follows:

- Range 1 = All encasement sizes greater than 2 inches to and including 6 inches
- Range 2 = All encasement sizes greater than 6 inches to and including 10 inches
- Range 3 = All encasement sizes greater than 10 inches to and including 14 inches
- Range 4 = All encasement sizes greater than 14 inches to and including 18 inches
- Range 5 = All encasement sizes greater than 18 inches to and including 24 inches
- Range 6 = All encasement sizes greater than 24 inches

*(Encasement sizes of 2 inches internal diameter or less shall not be paid separately; but, shall be considered incidental to the carrier pipe.)* Payment under this bid item shall not include the carrier pipe. Carrier pipe shall be paid under a separate bid item. Please refer to the Utility Company's Specifications. If the Company does not have specifications, KYTC's Specifications shall be referenced. This item shall be paid LINEAR FEET (LF) when complete.

**W ENCASUREMENT STEEL OPEN CUT** This item shall include the steel encasement pipe size as specified on the plans and in the specifications, casing spacers, end seals, labor, and equipment to open cut and install the encasement in accordance with the plans and specifications, complete and ready for use. The size shall be the measured internal diameter of the encasement pipe. The size encasement to be paid under the size ranges specified in the bid items shall be as follows:

- Range 1 = All encasement sizes greater than 2 inches to and including 6 inches
- Range 2 = All encasement sizes greater than 6 inches to and including 10 inches
- Range 3 = All encasement sizes greater than 10 inches to and including 14 inches
- Range 4 = All encasement sizes greater than 14 inches to and including 18 inches
- Range 5 = All encasement sizes greater than 18 inches to and including 24 inches
- Range 6 = All encasement sizes greater than 24 inches

*(Encasement sizes of 2 inches internal diameter or less shall not be paid separately; but, shall be considered incidental to the carrier pipe.)* Payment under this bid item shall not include the carrier pipe. Carrier pipe shall be paid under a separate bid item. Please refer to the Utility Company's Specifications. If the Company does not have specifications, KYTC's Specifications shall be referenced. This item shall be paid LINEAR FEET (LF) when complete.

**W FIRE HYDRANT ADJUST** Includes all labor, equipment, excavation, materials, and backfill to adjust the existing fire hydrant using the fire hydrant manufacturer's extension kit for adjustments of 18" or less. Adjustments greater than 18" require anchoring couplings and vertical bends to adjust to grade. The Contractor will supply and install all anchor couplings, bends, fire hydrant extension, concrete blocking, restoration, granular drainage material, etc, needed to adjust the fire hydrant complete and ready for use as shown on the plans, and in accordance with the specifications and standard drawings. This also includes allowing for the utility owner inspector to inspect the existing fire hydrant prior to adjusting, contractor returning unusable fire hydrants to the utility owner warehouse and picking up a replacement hydrant. No additional payment will be made for rock excavation. Please refer to the Utility Company's Specifications. If the Company does not have specifications, KYTC's Specifications shall be referenced. This item shall be paid EACH (EA) when complete and ready for use.

**W FIRE HYDRANT ASSEMBLY** Includes all labor, equipment, new fire hydrant, isolating valve and valve box, concrete pad around valve box (when specified in specifications or plans), piping, anchoring tee, anchoring couplings, fire hydrant extension, excavation, concrete blocking, granular drainage material, backfill, and restoration, to install a new fire hydrant assembly as indicated on plans and on standard drawings complete and ready for use. No additional payment will be made for rock excavation. Please refer to the Utility Company's Specifications. If the Company does not have specifications, KYTC's Specifications shall be referenced. This item shall be paid EACH (EA) when complete.

**W FIRE HYDRANT RELOCATE** This item includes all labor and equipment to remove the existing fire hydrant from its existing location and reinstalling at a new location. This item shall include a new isolating valve and valve box, concrete pad around valve box (when required in specifications or plans), new piping, new anchoring tee, anchoring couplings, fire hydrant extensions, concrete blocking, restoration, granular drainage material, excavation, and backfill as indicated on plans, specifications, and on standard drawings complete and ready for use. This item shall also include allowing for utility owner inspector to inspect the existing fire hydrant prior to reuse, contractor returning unusable fire hydrants to the utility owner warehouse and picking up a replacement hydrant for use, if the existing fire hydrant is determined unfit for reuse. No additional payment will be made for rock excavation. Please refer to the Utility Company's Specifications. If the Company does not have specifications, KYTC's Specifications shall be referenced. This item shall be paid EACH (EA) when complete.

**W FIRE HYDRANT REMOVE** This bid item includes removal of an abandoned fire hydrant, isolating valve, and valve box to the satisfaction of the engineer. The removed fire hydrant, isolating valve and valve box shall become the property of the contractor for his disposal as salvage or scrap. Please refer to the Utility Company's Specifications. If the Company does not have specifications, KYTC's Specifications shall be referenced. This item shall be paid EACH (EA) when complete.

**W FLUSH HYDRANT ASSEMBLY** This item shall include the flushing hydrant assembly, service line, tapping the main, labor, equipment, excavation, backfill, and restoration required to install the flush hydrant at the location shown on the plans and in accordance with the specifications and standard drawings, complete and ready for use. Please refer to the Utility Company's Specifications. If the Company does not have specifications, KYTC's Specifications shall be referenced. This item shall be paid EACH (EA) when complete.

**W FLUSHING ASSEMBLY** This item shall include the flushing device assembly, service line, meter box and lid, tapping the main, labor, equipment, excavation, backfill, and restoration required to install the

flushing device at the location shown on the plans and in accordance with the specifications and standard drawings, complete and ready for use. Please refer to the Utility Company's Specifications. If the Company does not have specifications, KYTC's Specifications shall be referenced. This item shall be paid EACH (EA) when complete.

**W LEAK DETECTION METER** This item is for payment for installation of a water meter at main valve locations where shown on the plans for detection of water main leaks. The meter shall be of the size and type specified in the plans or specifications. This item shall include all labor, equipment, meter, meter box or vault, connecting pipes between main and meter, main taps, tapping saddles, casting, yoke, and any other associated material needed for installation of a functioning water meter in accordance with the plans and specifications, complete and ready for use. No separate payment will be made under any other contract item for connecting pipe or main taps. Any and all leak detection meters shall be paid under one bid item included in the contract regardless of size. No separate bid items will be established for size variations. Please refer to the Utility Company's Specifications. If the Company does not have specifications, KYTC's Specifications shall be referenced. This item shall be paid EACH (EA) when complete and ready for use.

**W LINE MARKER** This item is for payment for furnishing and installing a water utility line marker as specified by the utility owner specifications and plans. A line marker may consist of a post or monument of whatever materials specified and shall include markings and/or signage on same as specified by plans or specifications. This item shall include all labor, equipment, and materials needed for complete installation of the marker. This item shall be paid EACH (EA) when complete.

**W MAIN POINT RELOCATE** This item is intended for payment for horizontal and/or vertical relocation of a short length of an existing main at the locations shown on the plans. This bid item is to be used to relocate an existing water main at point locations such as to clear a conflict at a proposed drainage structure, pipe or any other similar short relocation situation, and where the existing pipe material is to be reused. The contractor shall provide any additional pipe or fitting material needed to complete the work as shown on the plans and specifications. The materials provided shall be of the same type and specification as those that exist. Substitution of alternative materials shall be approved by the engineer in advance on a case by case basis. New polyethylene wrap is to be provided (if wrap exists or is specified in the specifications to be used). If it is necessary that the pipe be disassembled for relay, payment under this item shall also include replacement of joint gaskets as needed. Bedding and backfill shall be provided and performed the same as with any other pipe installation as detailed in the plans and specifications. Payment under this item shall be for each location requiring an existing main to be relocated horizontally or vertically regardless of pipe size or relocation length. No separate pay items will be established for pipe size variations or relocation segment length variations. Water Main Relocate shall not be paid on a linear feet basis; but, shall be Paid EACH (EA) at each location when complete and placed in service. Please refer to the Utility Company's Specifications. If the Company does not have specifications, KYTC's Specifications shall be referenced.

**W METER** This item is for payment for installation of all standard water meters of all sizes 2 inches ID or less as specified on the plans. This item shall include all labor, equipment, meter, meter box, casting, yoke, and any other associated material needed for installation of a functioning water meter in accordance with the plans and specifications, complete and ready for use. This item shall include connections to the new or existing water service line. Please refer to the Utility Company's Specifications. If the Company does not have specifications, KYTC's Specifications shall be referenced. This item shall be paid EACH (EA) when complete.

**W METER ADJUST** This item includes all labor, equipment, excavation, materials, backfill, restoration, and etc., to adjust the meter casting to finished grade (whatever size exists) at the location shown on the plans or as directed in accordance with the specifications and standard drawings complete and ready for use. Please refer to the Utility Company's Specifications. If the Company does not have specifications, KYTC's Specifications shall be referenced. This item shall be paid EACH (EA) when complete.

**W METER RELOCATE** This item includes all labor, equipment, excavation, additional fittings, disinfection, testing, restoration, and etc., to relocate the existing water meter (whatever size exists), meter yoke, meter box, casting, and etc., from its old location to the location shown on the plans or as directed, in accordance with the specifications and standard drawings complete and ready for use. The new service pipe (if required) will be paid under short side or long side service bid items. Any and all meter relocations of 2 inches or less shall be paid under one bid item included in the contract regardless of size. Each individual relocation shall be paid individually under this item; however, no separate bid items will be established for meter size variations of 2 inches ID or less. Please refer to the Utility Company's Specifications. If the Company does not have specifications, KYTC's Specifications shall be referenced. This item shall be paid EACH (EA) when complete.

**W METER VAULT SIZE RANGE 1 OR 2** This item is for payment for installation of an underground structure for housing of a larger water meter, fittings, and valves as required by the plans and specifications. This item shall include all labor, equipment, excavation, concrete, manhole castings or access doors, the specified meter(s) valve(s), all piping, and fitting materials associated with installing a functioning meter and vault in accordance with the plans, standard drawings, and specifications, complete and ready for use. The size shall be the measured internal diameter of the meter and piping to be installed. The size meter vault to be paid under size 1 or 2 shall be as follows:

- Size Range 1 = All meter and piping sizes greater than 2 inches up to and including 6 inches
- Size Range 2 = All meter and piping sizes greater than 6 inches

This item shall be paid EACH (EA) when complete. Please refer to the Utility Company's Specifications. If the Company does not have specifications, KYTC's Specifications shall be referenced.

**W METER/FIRE SERVICE COMBO VAULT** This item is for payment for installation of an underground structure for housing of a water meter and fire service piping, fittings, and valves as required by the plans and specifications. This item shall include all labor, equipment, excavation, concrete, manhole castings or access doors, the specified meter(s), valve(s), all piping, and fitting materials associated with installing a functioning meter and fire service vault in accordance with the plans and specifications, complete and ready for use. Please refer to the Utility Company's Specifications. If the Company does not have specifications, KYTC's Specifications shall be referenced. This item shall be paid EACH (EA) when complete.

**W METER WITH PRESSURE REDUCING VALVE (PRV)** This item is for payment for installation of all standard water meters with pressure reducing valves (PRV) of all sizes 2 inches ID or less as specified on the plans. This item shall include all labor, equipment, meter, PRV, meter box, casting, yoke, and any other associated material needed for installation of a functioning water meter with PRV in accordance with the plans and specifications, complete and ready for use. This item shall include connections to the new or existing water service line. Please refer to the Utility Company's Specifications. If the Company does not have specifications, KYTC's Specifications shall be referenced.

This item shall be paid EACH (EA) when complete.

**W PIPE** This description shall apply to all PVC, ductile iron, and polyethylene/plastic pipe bid items of every size and type to be used as water main, except those bid items defined as “Special”. This item includes the pipe specified by the plans and specifications, all fittings (including, but not limited to, bends, tees, reducers, plugs, and caps), tracing wire with test boxes (if required by specification), polyethylene wrap (when specified), labor, equipment, excavation, bedding, restoration, testing, sanitizing, backfill, and etc., required to install the specified new pipe and new fittings at the locations shown on the plans, or as directed, in accordance with the specifications and standard drawings complete and ready for use. No additional payment will be made for rock excavation. This bid item includes material and placement of flowable fill under existing and proposed pavement, and wherever else specified on the plans or in the specifications. **This item shall include all temporary and permanent materials and equipment required to pressure test and sanitize mains including, but not limited to, pressurization pumps, hoses, tubing, gauges, main taps, saddles, temporary main end caps or plugs and blocking, main end taps for flushing, chlorine liquids or tablets for sanitizing, water for testing/sanitizing and flushing (when not supplied by the utility), chlorine neutralization equipment and materials, and any other items needed to accomplish pressure testing and sanitizing the main installation.** This item shall also include pipe anchors, at each end of polyethylene pipe runs when specified to prevent the creep or contraction of the pipe. Measurement of quantities under this item shall be through fittings, encasements, and directional bores (only when a separate carrier pipe is specified within the directional bore pipe). Measurements shall be further defined to be to the center of tie-in where new pipe contacts existing pipe at the center of connecting fittings, to the outside face of vault or structure walls, or to the point of main termination at dead ends. No separate payment will be made under pipe items when the directional bore pipe is the carrier pipe. Please refer to the Utility Company’s Specifications. If the Company does not have specifications, KYTC’s Specifications shall be referenced. This item shall be paid LINEAR FEET (LF) when complete.

**W PLUG EXISTING MAIN** This item shall include the specified plug, concrete blocking and/or anchoring, labor, equipment, excavation, backfill, and restoration required to install the plug in an existing in-service main that is to remain at the location shown on the plans or as directed in accordance with the specifications. Any and all plugs on all existing in-service mains shall be paid under one bid item included in the contract regardless of size. No separate bid items will be established for size variations. Please refer to the Utility Company’s Specifications. If the Company does not have specifications, KYTC’s Specifications shall be referenced. This item shall be paid EACH (EA) when complete.

*NOTE: This utility bid item is not to be paid on new main installations or abandoned mains. This pay item is to plug existing in-service mains only. Plugs on new mains are incidental to the new main just like all other fittings.*

*NOTE: Plugging of existing abandon mains shall be performed and paid in accordance with Section 708.03.05 of KYTC Standard Specifications For Road And Bridge Construction and paid using Bid Code 01314 Plug Pipe.*

**W PRESSURE REDUCING VALVE** This description shall apply to all pressure reducing valves (PRV) of every size required in the plans and specifications except those bid items defined as “Special”. Payment under this description is to be for PRVs being installed with new main. This item includes the PRV as specified in the plans and specifications, polyethylene wrap (if required by specification), labor, equipment, excavation, anchoring (if any), pit or vault, backfill, restoration, testing, disinfection, and etc., required to install the specified PRV at the location shown on the plans in accordance with the specifications and standard drawings complete and ready for use. If required on plans and/or proposed adjoining DIP is restrained, PRVs shall be restrained. PRV restraint shall be considered incidental to the

PRV and adjoining pipe. Please refer to the Utility Company's Specifications. If the Company does not have specifications, KYTC's Specifications shall be referenced. This item shall be paid EACH (EA) when complete.

**W PUMP STATION** This item is for payment for installation of pumps and an above or below ground structure for housing of the pumps. This item shall include all pumps, piping, fittings, valves, electrical components, building materials, concrete, any other appurtenances, labor, equipment, excavation, and backfill, to complete the pump station installation as required by the plans, standard drawings, and specifications, complete and ready for use. Please refer to the Utility Company's Specifications. If the Company does not have specifications, KYTC's Specifications shall be referenced. This item shall be paid LUMP SUM (LS) when complete.

**W REMOVE TRANSITE (AC) PIPE** This item shall include all labor, equipment, and materials needed for removal and disposal of the pipe as hazardous material. All work shall be performed by trained and certified personnel in accordance with all environmental laws and regulations. Any and all transite AC pipe removed shall be paid under one bid item included in the contract regardless of size. No separate bid items will be established for size variations. Please refer to the Utility Company's Specifications. If the Company does not have specifications, KYTC's Specifications shall be referenced. This item shall be paid LINEAR FEET (LF) when complete.

**W SERVICE LONG SIDE** This bid item description shall apply to all service line installations of every size bid up to and including 2 inch inside diameter, except those service bid items defined as "Special". This item includes the specified piping material, main tap, tapping saddle (if required), and corporation stop materials, coupling for connecting the new piping to the surviving existing piping, encasement of 2 inches or less internal diameter (if required by plan or specification), labor, equipment, excavation, backfill, testing, disinfection, and restoration, at the locations shown on the plans or as directed, in accordance with the specifications and standard drawings, complete and ready for use. This bid item is to pay for service installations where the ends of the service connection are on opposite sides of the public roadway and the service line crosses the centerline of the public roadway as shown on the plans. The length of the service line is not to be specified. Payment under this item shall not be restricted by a minimum or maximum length. The contractor shall draw his own conclusions as to the length of piping that may be needed. Payment under this item shall include boring, jacking, or excavating across the public roadway for placement. Placement of a service across a private residential or commercial entrance alone shall not be reason to make payment under this item. Private or commercial entrances shall not be considered a public roadway in defining payment under this item. This pay item does not include installation or relocation of meters. Meters will be paid separately. No additional payment will be made for rock excavation or for special bedding required in rock excavation. Please refer to the Utility Company's Specifications. If the Company does not have specifications, KYTC's Specifications shall be referenced. This item shall be paid EACH (EA) when complete.

**W SERVICE SHORT SIDE** This bid item description shall apply to all service line installations of every size up to and including 2 inch internal diameter, except those service bid items defined as "Special". This item includes installation of the specified piping material of the size specified on plans, encasement of 2 inches or less internal diameter (if required by plan or specification), main tap, tapping saddle (if required), corporation stop, coupling for connecting the new piping to the surviving existing piping, labor, equipment, excavation, backfill, testing, disinfection, and restoration, at the locations shown on the plans or as directed, in accordance with the specifications and standard drawings, complete and

ready for use. This bid item is to pay for service installations where both ends of the service connection are on the same side of the public roadway, or when an existing service crossing a public roadway will remain and is being extended, reconnected, or relocated with all work on one side of the public roadway centerline as shown on the plans. The length of the service line is not to be specified and shall not be restricted to any minimum or maximum length. Payment shall be made under this item even if the service crosses a private residential or commercial entrance; but, not a public roadway. Private or commercial entrances shall not be considered a public roadway in defining payment under this item. The contractor shall draw his own conclusions as to the length of piping that may be needed. This pay item does not include installation or relocation of meters. Meters will be paid separately. No additional payment will be made for rock excavation or for bedding required in rock excavation. Please refer to the Utility Company's Specifications. If the Company does not have specifications, KYTC's Specifications shall be referenced. This item shall be paid EACH (EA) when complete.

**W SERVICE RELOCATE** This item is for the relocation of an existing water service line where a meter is not involved, and where an existing service line can easily be adjusted by excavating alongside and moving the line horizontally and/or vertically a short distance without cutting the service line to avoid conflicts with road construction. This item shall include excavation, labor, equipment, bedding, and backfill to relocate the line in accordance with the plans and specifications complete and ready for use. Payment under this item shall be for each location requiring relocation. Payment shall be made under this item regardless of service size or relocation length. No separate pay items will be established for size or length variation. Please refer to the Utility Company's Specifications. If the Company does not have specifications, KYTC's Specifications shall be referenced. This item shall be paid EACH (EA) when complete.

**W STRUCTURE ABANDONMENT** This item is to be used to pay for abandonment of larger above or below ground water structures such as meter vaults, fire pits, pump stations, tanks, and etc. Payment under this item shall not be limited to size or scope; however structures with connecting pipes of 2 inches or less shall not be paid under this item; but, shall be considered incidental to water construction, (i.e., abandonment of standard water meters up to and including 2 inches would not be paid under this item). Payment under this item shall include all labor, equipment, and compacted fill or flowable fill for abandonment of the structure in place and restoration complete. No separate bid items will be established for size or structure variations. Please refer to the Utility Company's Specifications. If the Company does not have specifications, KYTC's Specifications shall be referenced. This item shall be paid EACH (EA) when complete.

**W STRUCTURE REMOVAL** This item is to be used to pay for removal of larger above or below ground water structures such as meter vaults, fire pits, pump stations, tanks, and etc. Payment under this item shall not be limited to size or scope; however structures with connecting pipes of 2 inches or less shall not be paid under this item; but, shall be considered incidental to water construction, (i.e., removal of standard water meters up to and including 2 inches would not be paid under this item). Payment under this item shall include all labor, equipment, and compacted backfill for removal of the structure and restoration complete. No separate bid items will be established for size or structure variations. Please refer to the Utility Company's Specifications. If the Company does not have specifications, KYTC's Specifications shall be referenced. This item shall be paid EACH (EA) when complete.

**W TAPPING SLEVE AND VALVE SIZE 1 OR 2** This item shall include the specified tapping sleeve, valve, valve box, concrete pad around valve box (when required in specifications or plans), labor, and equipment to install the specified tapping sleeve and valve, complete and ready for use in accordance with

the plans and specifications. The size shall be the measured internal diameter of the live pipe to be tapped. The size tapping sleeve and valve to be paid under sizes 1 or 2 shall be as follows:

Size 1 = All live tapped main sizes up to and including 8 inches

Size 2 = All live tapped main sizes greater than 8 inches

Please refer to the Utility Company's Specifications. If the Company does not have specifications, KYTC's Specifications shall be referenced. This item shall be paid EACH (EA) when complete.

**W TIE-IN** This bid description shall be used for all main tie-in bid items of every size except those defined as "Special". This item includes all labor, equipment, excavation, fittings, sleeves, reducers, couplings, blocking, anchoring, restoration, disinfection, testing and backfill required to make the water main tie-in as shown on the plans, and in accordance with the specifications complete and ready for use. Pipe for tie-ins shall be paid under separate bid items. This item shall be paid EACH (EA) when complete.

**W VALVE** This description shall apply to all valves of every size required in the plans and specifications except those bid items defined as "Special". Payment under this description is to be for gate or butterfly valves being installed with new main. This item includes the valve as specified in the plans and specifications, polyethylene wrap (if required by specification), labor, equipment, excavation, anchoring (if any), valve box and valve stem extensions, backfill, concrete pad around valve box (if required by specification), restoration, testing, disinfection, and etc., required to install the specified valve at the location shown on the plans in accordance with the specifications and standard drawings complete and ready for use. If required on plans and/or proposed adjoining DIP is restrained, valves shall be restrained. Valve restraint shall be considered incidental to the valve and adjoining pipe. This description does not apply to cut-in valves. Please refer to the Utility Company's Specifications. If the Company does not have specifications, KYTC's Specifications shall be referenced. This item shall be paid EACH (EA) when complete.

**W VALVE ANCHOR EXISTING** This bid item is intended to pay for installation of restraint hardware on an existing valve where no restraint exists to hold the valve in place to facilitate tie-ins and other procedures where restraint is prudent. This work shall be performed in accordance with water specifications and plans. This bid item shall include all labor equipment, excavation, materials and backfill to complete restraint of the designated valve, regardless of size, at the location shown on the plans, complete and ready for use. Materials to be provided may include, but is not limited to, retainer glands, lugs, threaded rod, concrete, reinforcing steel or any other material needed to complete the restraint. Should the associated valve box require removal to complete the restraint, the contractor shall reinstall the existing valve box, the cost of which shall be considered incidental to this bid item. No separate bid items are being provided for size variations. All sizes shall be paid under one bid item. Please refer to the Utility Company's Specifications. If the Company does not have specifications, KYTC's Specifications shall be referenced. This item shall be paid EACH (EA) when complete.

**W VALVE BOX ADJUST** Includes all labor, equipment, valve box and valve stem extensions (if required), excavation, backfill, concrete pad around valve box (when specified in specifications or plans), restoration, and etc., to adjust the top of the box to finished grade complete and ready for use. Please refer to the Utility Company's Specifications. If the Company does not have specifications, KYTC's Specifications shall be referenced. This item shall be paid EACH (EA) when complete.

**W VALVE CUT-IN** This bid description is for new cut-in valve installations of all sizes where installation is accomplished by cutting out a section of existing main. This item shall include cutting the existing pipe, supplying the specified valve, couplings or sleeves, valve box, concrete pad around valve box (when required in specifications or plans), labor, equipment, and materials to install the valve at the locations shown on the plans, or as directed by the engineer, complete and ready for use. Any pipe required for installation shall be cut from that pipe removed or supplied new by the contractor. No separate payment will be made for pipe required for cut-in valve installation. Please refer to the Utility Company's Specifications. If the Company does not have specifications, KYTC's Specifications shall be referenced. This item shall be paid EACH (EA) when complete.

**W VALVE VAULT** This item is for payment for installation of an underground structure for housing of specific valve(s) as required by the plans and specifications. This item shall include all labor, equipment, excavation, concrete, manhole castings or doors, the specified valve(s), all piping, and fitting materials associated with installing a functioning valve vault in accordance with the plans, standard drawing, and specifications, complete and ready for use. Please refer to the Utility Company's Specifications. If the Company does not have specifications, KYTC's Specifications shall be referenced. This item shall be paid EACH (EA) when complete.

## **SUPPLEMENTARY SPECIFICATIONS**

### **KY 864-Fegenbush Lane @ Fenwick WATER MAIN RELOCATION PROJECT KYTC Item No. 5-9016.00**

#### **PROJECT LIMITS**

Limits of the referenced project include **Fegenbush Lane** between **Woodrow Way** to **Fenwick Drive**. See plans for location.

#### **PROJECT SUMMARY**

The referenced project consists of the supply and installation of approximately **570 +/-** linear feet of 12-inch Pressure Class 350 ductile iron water main (using traditional trench installation techniques). Also included with the project is the transfer, renewal, relocation or discontinue of **5 +/-** customer services.

#### **SCOPE OF WORK**

1. Supply and Install **570 +/-** linear feet of 12-inch Pressure Class 350 ductile iron water main along Fegenbush Lane.
2. Complete all tie-ins as shown on the plans.
3. Transfer, renew, relocate and/or discontinue **5** customer services.

#### **GENERAL INFORMATION**

4. **The contractor is bound by and shall comply with the provisions of the "Louisville Water Company Technical Specifications and Standard Drawings for Pipeline Construction" (2008 Edition) which shall govern work on this project with the following additions/exceptions:** All materials shall be supplied and installed by the Contractor. Louisville Water Company will not supply any material. Contractor shall disregard any reference in the Louisville Water Company Technical Specification where it says Louisville Water Company shall/will supply materials.

#### **GENERAL REQUIREMENTS**

5. All work performed for the installation and relocation of the water main and related construction must be performed by an LWC pre-qualified contractor in the following category:
  - Category 1: 4" – 16" Ductile Iron Water Main

### **PIPELINE MATERIALS**

6. Unless otherwise approved by the LWC Project Manager, all pipe replacement work in this project scope shall be constructed with Contractor-supplied Pressure Class 350 ductile iron pipe in accordance with the plans using traditional trenching techniques. The contractor shall provide LWC with material submittals for all materials that the contractor plans to use for LWC work including but not limited to pipe, valves, fittings, casing pipe, etc. The submittals shall be reviewed and approved by the LWC Project Manager prior to installation of any material. The contractor shall provide alternate materials for any materials that the LWC Project Manager rejects until an acceptable material is selected by the contractor as approved by the LWC Project Manager. Material submittal review takes approximately two weeks for each submittal.

### **TRAFFIC CONTROL**

7. This project will be bid and constructed in conjunction with the Kentucky Transportation Cabinet's (KYTC) KY 864-Fegenbush Lane @ Fenwick project; therefore, no KYTC permits will be required. Contractor shall obtain all permits through KYTC and follow the procedures as specified.

### **VIDEO RECORDING**

8. A preconstruction Video Recording of the water relocation limits shall be completed by the contractor and provided to the LWC Project Manager prior to construction.
9. Video Recording shall be provided in DVD format

### **SITE WORK**

10. Field modifications to the proposed pipeline alignment may be necessary to avoid or minimize the effects of potential conflicts. To avoid potential conflicts with existing utilities located perpendicular and/or parallel to the proposed main, the Contractor should anticipate the need to use offsets, bends and fittings when installing the new main, and for large service connections at no additional cost to LWC or KYTC.
11. Utility locations are shown on the plans from available information and are approximate. The contractor is responsible for locating all existing utilities including water line facilities prior to start of construction. The contractor is responsible for relocating any existing utility that is in conflict with the proposed construction at no additional cost to LWC or KYTC.

### **RETURN OF USED HYDRANTS**

12. Fire hydrants that are discontinued, abandoned or replaced shall be removed and returned with caps to the LWC Allmond Avenue Warehouse. The contractor shall also complete the "RETURN OF USED FIRE HYDRANTS" form, sign and submit the form to the inspector for record keeping and proper accounting. Any removed hydrant that is not returned to the LWC warehouse will be invoiced to the contractor in the amount of \$75 per hydrant.
13. Fire Hydrant Extension Kits shall not be used for any fire hydrant installation on this project. Contractor shall adjust the depth of the water main at the location where a hydrant will be installed to accommodate the height of a standard fire hydrant.

### **EXCAVATION**

14. Excavation on this project shall be unclassified.
15. Rock shall be removed using mechanical methods (backhoe, hoe ram, or rock trenching machine). Blasting shall not be permitted.

### **INSTALLATION, HANDLING AND STORAGE**

16. Forklifts' forks or other material handling equipment shall not be inserted into the barrels of pipe, valves or other fittings to lift or move them or for any other construction activity.
17. Pipe lengths should be stored and placed on level ground. Pipe should be stored at the job site in the unit packaging provided by the manufacturer. Caution should be exercised to avoid compression, damage, or deformation to the pipe. The interior of the pipe, as well as all end surfaces, should be kept free from dirt and foreign matter.
18. Pipe shall be handled and supported with the use of woven fiber pipe slings or approved equal. Care shall be exercised when handling the pipe to not cut, gouge, scratch or otherwise abrade the piping in any way.
19. Pipe shall not be stored on-site for periods greater than 3 months or as approved by the LWC Inspector and Project Manager.
20. Pipe shall be stored and stacked per the pipe supplier's guidelines and as approved by the LWC Inspector and Project Manager.

### **BACKFILLING PROCEDURES AND TAMPING**

21. When under the *pavement in state right-of-way*, the final backfill material shall be selected, placed and compacted in accordance with section 7 of the LWC Technical Specifications and Standard Drawing No. 4000 – State of Kentucky Backfill and Paving Restoration.
22. When under *pavement other than state right-of-way*, (side streets, driveways, and entrances), the final backfill material shall be selected, placed and compacted in accordance with section 7 of the LWC Technical Specifications and Standard Drawing No. 4100 – Louisville and Jefferson County Metro Backfill and Paving Restoration.
23. If septic system / lateral field is encountered, contractor shall put 6 inches of compacted DGA on all sides of pipe for a distance of 5 feet on each side of line encountered.

### **PLACING WATER MAIN IN SERVICE**

24. All new ductile iron and PVC pipe installations longer than 50 feet shall be pig cleaned. Ductile iron and PVC pipe sections shorter than 50 feet in length may require pig cleaning at the direction of the LWC Construction Inspector. Pigs shall be used one time and discarded.
25. A chlorine injection system shall be used to fill the new main. The LWC Construction Inspector will provide the equipment needed to inject the chlorine-based solution into the main. The Contractor shall assist the LWC Construction Inspector with the connection of hoses and the operation of valves.

### **CUSTOMER SERVICES**

26. The renewal of 5/8" services shall include the upsizing of the service to 3/4".
27. The contractor shall review the proposed private/public service lines as shown on the plans prior to bidding. The contractor is responsible for relocating the customer's service line (the line from the main to the meter and the line from the meter to the right of way or property line. The contractor shall coordinate each relocated service with the property owner and obtain property owners approval prior to any construction outside of the right-of-way. The property shall be restored to the satisfaction of the property owner.
28. Prior to beginning any work that requires a shut-down of the main or individual services, the Contractor shall make a thorough evaluation of each service connection and meter vault within the limits of the shut-down. Discrepancies between the field conditions and the Project Plans shall be discussed with the LWC Construction Inspector.

29. The use of copper couplings under paved areas shall be avoided. In situations where the new main is located on the opposite side of the roadway from the existing main or where the new main is located in the roadway and more than two feet from the existing main, "long" service transfers shall be completed by advancing a new service line from the new main to the meter vault.
30. The type, size and condition of the existing customer service at the property line shall be verified before completing the service reconnection. Where lead is encountered at the property line and an existing property connection is not found, the Contractor shall extend the service excavation up to three (3) feet behind the property line to remove additional lead and to search for an existing property connection. The service reconnection shall then be completed at the three-foot distance, or less, if an existing property connection is encountered.
31. During lead service renewals, meter vault frames and covers that have the old style "1/4-Turn" or "J-Hook" locking mechanisms shall be replaced with new frames and covers. Additionally, where covers are broken or inoperable the covers and frames shall be replaced. The removed frame and cover shall be returned to LWC for proper disposal.

### **WORK SCHEDULE**

32. A 'Staging 'Plan' for how the work is to proceed is to be presented by the contractor at the Preconstruction meeting. Staging of the work should try to minimize the time between installing the new main and working on or removing the existing water main so that the time between the restorations of the two events is minimized.
33. Normal work hours shall be limited to work hours approved by KYTC. All other work hour requests must be submitted by the contractor to the approving agency for approval after standard applications have been made and approved.
34. The Contractor shall anticipate the need to work after-hours and on weekends to accommodate all critical customer needs as directed by the LWC Project Manager. In addition, after-hour or weekend work may be needed to shut down transmission mains or to connect to a tank. All such work will be considered incidental to the project and no additional compensation will be provided. This after-hour work must be pre-approved by the LWC Project Manager.
35. In the case of an emergency, the Contractor shall immediately notify the LWC Construction Inspector. If the contractor can not reach the inspector, then they shall immediately notify the Radio Room or Project Manager. Prior to the actual shut-off, an attempt shall also be made to contact each customer (door-to-door) to alert customers of the emergency situation and the need to shut-off the main.

### **EROSION CONTROL MEASURES**

36. An erosion control plan is required for this project. An erosion control plan shall be prepared by the contractor and submitted to LWC for review. The erosion control plan shall be submitted by the contractor to the respective agencies upon request of LWC. The contractor is responsible for maintaining all erosion control measures within the project limits in accordance with the latest MSD, Louisville Metro and LWC specifications. The contractor is responsible for making all erosion control modifications within the project limits required by MSD, Louisville Metro, LWC, or any other permitting authority at no additional cost to LWC. The contractor is responsible to rectify any disputes that may arise due to inadequate erosion control measures as determined by MSD, Louisville Metro, LWC, or any other permitting authority.
37. As a minimum, erosion control features shall be provided at catch basins, headwalls and in small ditches where associated construction procedures may cause the transport of sediment into the storm drainage system. When soil is disturbed within grassy areas, erosion control protection shall also be provided at yard drains. Care will be required to minimize stockpiling or placing backfill or excavated materials on roadways.

### **PIPELINE CONSTRUCTION**

38. Prior to the start of any work at the site (including saw-cutting), the Contractor and LWC Construction Inspector shall review the proposed pipeline alignment with respect to the utility locations marked by the local utility locate company, trees, and other existing site improvements.
39. Standard burial depth for new water mains is 42 inches, as measured from the top of ground to the top of the newly installed pipe. While the Contractor is expected to adhere to this standard burial depth requirement at all times, it is understood that revisions to the burial depth will be necessary when the installation of mains and large services conflict with existing utilities and other site improvements. Prior approval from the LWC Project Manager is required for these deviations.
40. The type, size and condition of the existing pipe shall be verified prior to completing tie-ins. When the existing pipe is other than indicated on the Project Plans, the LWC Construction Inspector or LWC Project Manager shall be contacted immediately to assess the need for revising the tie-in location. The Contractor shall be compensated in accordance with the supplementary unit prices for any additional pipeline installed to revise the tie-in location.

41. All tree root systems that require boring shall be bored a minimum of 30 feet; 15 feet either side of the tree trunk. The bore shall be located a minimum of 4 feet below the ground surface and a minimum of 5 feet from the center of the tree.

### **RESTORATION**

42. Unless otherwise noted on the Project Plans, surface restoration of grassy areas shall consist of seed and straw. The seed type used shall match the existing grass. Reseeded areas that are located within ditches or on other sloped ground shall be covered with erosion control netting secured with pins or stakes. As an alternative, the Contractor may utilize prefabricated matting containing mulch, seed, and fertilizer.
43. All driveways requiring replacement shall be restored in the following manner: (1) concrete driveways shall be replaced in their entirety to the nearest construction joint and (2) asphalt driveways shall be restored via a utility cut, as approved by the inspector and property owner.

### **POST CONSTRUCTION**

44. All in-line and service valves installed and/or operated during the completion of this project shall be inspected after construction to verify that all valves used by the Contractor are left in the proper operating position. Unless otherwise noted, or directed, all gates shall be left open.

### **WARRANTY**

45. The Contractor warrants to the Company that materials and equipment furnished by the Contractor under the Contract will be new and of good quality unless otherwise required or permitted by the Contract Documents, that the Work will be free from defects not inherent in the quality required or permitted, and that the Work will conform to the requirements of the Contract Documents. Work not conforming to these requirements, including substitutions not properly approved and authorized, may be considered defective. If required by the Company, the Contractor shall furnish satisfactory evidence as to the kind and quality of materials and equipment.
46. Contractor's obligation to perform and complete the Work in accordance with the Contract Documents shall be absolute. None of the following will constitute an acceptance of Work that is not in accordance with the Contract Documents or a release of the Contractor's obligation to perform the work in accordance with the Contract Documents:
  1. Observations by the Project Manager;
  2. Payment by the Company;

3. Issuance of a certificate of Substantial Completion;
  4. Use or occupancy of any part of the Work by the Company;
  5. Review of Shop Drawings or other Submittals;
  6. Any inspection, test, or approval by others; or
  7. Any correction of defective Work by the Company.
47. Failure on the part of the Company to insist on strict performance by the Contractor of any provision of this Contract is not a waiver of any of the Company's rights and/or remedies, nor shall it relieve the Contractor from performing any subsequent obligations strictly in accordance with the terms of this Contract.
48. The Company may, at its option, waive compliance with any particular Contract requirement. No waiver shall be effective unless in writing and signed by both the Company and the Contractor. Written waivers shall be limited to the specified provisions of this Contract specifically referred to herein, and shall not be deemed a waiver of any other provision. The written waiver shall not constitute a continuing waiver unless it states otherwise.
49. All work shall be warranted for two (2) years from the date of Final Completion unless specified otherwise. Paved surfaces and restoration of structures will be warranted for five (5) years. Contractor-furnished iron pipe materials shall be warranted for five (5) years after the iron pipeline is placed in service. Satisfactory performance of the iron water main and appurtenances, as they relate to installation, shall be warranted for two (2) years after the iron pipeline is placed in service. The Company reserves the right to require Contractor's presence at scheduled Warranty inspections held within the 12-month period following acceptance of the Project.
50. Contractor shall assign to the Company all manufacturers' warranties. All such warranties shall be directly enforceable by the Company. Such assignment shall in no way affect the Contractor's responsibilities and duties during the warranty period.



# **Louisville Water**

## **4” -20” Pipeline**

# **Material Specification**

**March 2020**

## Contents

|   |           |
|---|-----------|
| <b>03 21 00 - REINFORCEMENT BARS.....</b>                                 | <b>1</b>  |
| SECTION 03 21 16 EPOXY-COATED REBAR ANCHORS .....                         | 1         |
| <b>SECTION 04 22 00 CONCRETE UNIT MASONRY .....</b>                       | <b>2</b>  |
| <b>22 11 00 FACILITY WATER DISTRIBUTION .....</b>                         | <b>3</b>  |
| SECTION 22 11 16.02 BRASS FITTINGS AND VALVES .....                       | 3         |
| <b>26 05 00 – COMMON WORK RESULTS FOR ELECTRICAL.....</b>                 | <b>4</b>  |
| SECTION 26 05 19 LOW-VOLTAGE ELECTRICAL POWER CONDUCTORS AND CABLES ..... | 4         |
| <b>31 25 00 – EROSION &amp; SEDIMENTATION CONTROLS.....</b>               | <b>5</b>  |
| SECTION 31 25 14.16 ROLLED EROSION CONTROL MATS AND BLANKETS .....        | 5         |
| <b>33 01 00 - OPERATION &amp; MAINTENANCE OF UTILITIES .....</b>          | <b>6</b>  |
| SECTION 33 01 10.54 CLEANING OF WATER UTILITY PIPING (POLY PIGS).....     | 6         |
| <b>33 05 00 – COMMON WORK RESULTS FOR UTILITIES.....</b>                  | <b>7</b>  |
| SECTION 33 05 07.24 STEEL CASING PIPE.....                                | 7         |
| SECTION 33 05 07.24.01 CASING SPACERS .....                               | 8         |
| SECTION 33 05 09.43 TAPPING SADDLES .....                                 | 9         |
| SECTION 33 05 09.44 TAPPING SLEEVE & GATE VALVE.....                      | 10        |
| SECTION 33 05 19 DUCTILE IRON PIPE.....                                   | 12        |
| SECTION 33 05 19.01 POLYWRAP FOR WRAPPING DUCTILE IRON .....              | 14        |
| SECTION 33 05 19.02 POLYTAPE FOR WRAPPING DUCTILE IRON.....               | 15        |
| SECTION 33 05 31.16 PVC PIPE.....   | 16        |
| SECTION 33 05 31.26 SERVICE SLEEVES .....                                 | 18        |
| SECTION 33 05 73 VALVE BOXES, LIDS, & RISERS.....                         | 19        |
| SECTION 33 05 73.01 PLASTIC METER VAULTS & EXTENSION RINGS.....           | 20        |
| SECTION 33 05 73.02 METER SETTERS .....                                   | 21        |
| SECTION 33 05 73.03 PIPE REPAIR SLEEVES .....                             | 23        |
| SECTION 33 05 73.04 FRAMES, RISERS, AND MONITOR CASTINGS .....            | 24        |
| SECTION 33 05 81 ALUMINUM HATCHES .....                                   | 25        |
| <b>40 05 00 - COMMON WORK RESULTS FOR PROCESS INTERCONNECTIONS .....</b>  | <b>26</b> |
| SECTION 40 05 17 COPPER TUBING .....                                      | 26        |
| SECTION 40 05 61.23 SWING CHECK VALVES .....                              | 27        |
| SECTION 40 05 61.24 FLAT FACED FLANGED SPOOL PIECES .....                 | 29        |
| SECTION 40 05 61.25 MJ RESTRAINED JOINT ADAPTERS .....                    | 32        |

SECTION 40 05 61.26 BELL JOINT CLAMPS.....33  
 SECTION 40 05 61.27 DUCTILE IRON PIPE RESTRAINED JOINT GASKETS.....34  
 SECTION 40 05 61.28 RESTRAINT JOINT CLAMPS.....35  
 SECTION 40 05 61.29 DUCTILE IRON FITTINGS .....36  
 SECTION 40 05 61.30 REPAIR COUPLING AND GASKETS.....39  
 SECTION 40 05 65.23 VALVES AND APPURTENANCES.....40  
 SECTION 40 05 67.36 WATER PRESSURE REGULATORS FOR PRV .....42  
 SECTION 40 05 78.11 AIR RELEASE VACUUM VALVE .....43  
 SECTION 40 05 81.13 FIRE HYDRANTS .....45  
 SECTION 40 05 89 KEYTUBE .....47

**Appendix - List of Drawings**

SECTION 03 21 00 REINFORCING STEEL FOR ANCHORING GATE VALVES 5006  
 SECTION 33 05 73 VALVE BOX & LID 5000  
 SECTION 33 05 73.02 1-1/2" METER SETTER WITH 1" BYPASS 3204  
 SECTION 33 05 73.02 2" METER SETTER WITH 1" BYPASS 3205  
 SECTION 34 05 73.04 3" ELEVATOR RISER RING (J-HOOK STYLE) FOR SMALL  
 METER VAULT FRAMES AND LIDS 5102  
 SECTION 34 05 73.04 1-1/2" ELEVATOR RISER RING (J-HOOK) FOR SMALL METER  
 VAULT FRAMES AND LIDS 5103  
 SECTION 34 05 73.04 3" RISER (HEX HEAD BOLT) FOR SMALL METER VAULT  
 COVERS 5103B  
 SECTION 34 05 73.04 LIGHT & HEAVY VAULT FRAME 5104  
 SECTION 34 05 73.04 MONITOR LID RISER RING 5105  
 SECTION 34 05 73.04 MONITOR FLANGE & RING 5106  
 SECTION 40 05 61.24 WELDOLET FITTING 9004

**03 21 00 - REINFORCEMENT BARS**  
**SECTION 03 21 16**  
**EPOXY-COATED REBAR ANCHORS**

1. GENERAL

- A. Steel Reinforcing Bar Anchors shall conform to the requirements of ASTM A615 – Specification for Deformed and Plain Billet –Steel Bars for Concrete Reinforcement for Grade 60 reinforcing steel.
- B. Steel Reinforcing Bar Anchors shall be fusion bonded epoxy coated in accordance with ASTM A775 –Specification for Epoxy-Coated Reinforcing Steel Bars and the Concrete Reinforcing Steel Institute's Fusion Bonded Epoxy Coating Applicator Plant Certification Program. The fusion bonded epoxy coating shall show no evidence of separation from the bar and be free from holes, voids, contamination, cracks or other damaged areas.

2. PRODUCTS

- A. Fabrication: Reinforcing steel shall be accurately formed to the dimensions and shapes shown on Louisville Water Company Standard Drawing #5006. Standard Hooks (180° degrees) shall be bent around a pin having a diameter of 3 inches (3") for No.4 bars; 4.5 inches (4.5") for No.6 bars; 6 inches (6") for No. 8 bars; and 10.75 inches (10.75") for No. 10 bars. Bars shall be bent cold.
- B. Fabrication Tolerances:
  - 1. Sheared Length: +/- One inch (1")
  - 2. Bend Dimensions:
  - 3. +/-One Half inch (1/2") for #4 Bar Size.
  - 4. +/-One inch (1") for Larger than #4 Bar Size.
- C. Reinforcing Steel shall be rejected if the extent of the epoxy coating damage exceeds 1% of the surface area in any one-foot length.
- D. The proposed contractor(s) shall provide certification stating that the reinforcing steel and epoxy coating conform to the requirements of ASTM A615 and/or ASTM A775 Standards (latest editions) upon request by LWC.

**SECTION 04 22 00  
CONCRETE UNIT MASONRY**

1. GENERAL

- A. Provision of concrete blocks for supporting fire hydrants and temporary support of gate valves.
- B. Related work:
  - a. Fire hydrants and gate valves
- C. Submittals:
  - a. Submit manufacture's information showing the concrete block type, dimensions and compliance with ASTM C90.

2. PRODUCTS

- A. The concrete blocks shall be new, 4" x 8" x 16" solid concrete block, with actual dimensions of 3.625" x 7.625" x 15.625".
- B. The solid concrete block shall comply with ASTM C90 for normal weight load bearing concrete masonry units. The solid concrete block shall have a minimum weight of 31.25 lbs. and have a minimum compressive strength of 1,900 psi.

3. MANUFACTURERS

- A. The concrete block shall be as supplied by Lowes Home Improvement or approved equal.

**22 11 00 FACILITY WATER DISTRIBUTION**  
**SECTION 22 11 16.02**  
**BRASS FITTINGS AND VALVES**

1. GENERAL

- A. All items shall comply with applicable provisions of the AWWA C800 section 4 "material shall comply with the requirements of the Safe Drinking Water Act standards currently in effect for no lead brass". Louisville Water Company reserves the right to require the contractor to supply an affidavit from the manufacturer stating that the products provided comply.

2. PRODUCTS

- A. Contractor shall provide installation instructions with all couplings and valves and will be required to provide to the Inspectors.
- B. All items that the Louisville Water Company rejects as not conforming to standards shall be returned to the Contractor at the expense of the Contractor. If the items are found to be defective, they shall be replaced with like items at the Contractor's expense.
- C. Valves and fittings shall be complete and ready to install when shipped. The Contractor shall use care in preparing them for shipment to avoid damage during handling or transit. Damaged items will be returned at contractor's expense.
- D. Corporation stops shall be suitable for both dry and wet tapped connections on PVC and ductile iron water mains.
- E. All fittings in the Bidders Proposal Sheet described as "compression" style, shall be manufactured with a stainless steel gripper ring. The gripper ring shall be molded into the gasket and is drawn down when the nut is tightened, providing a mechanical restraint and hydraulic seal. In addition, the interior portion of the nut must have a transparent fluorocarbon coating that provides smooth torque transfer.
- F. Items 2050006 & 2050007 height must not exceed 7 *W'* from bottom of inlet to the top of the stop.

3. MANUFACTURERS

- A. Prequalified manufacturers of brass fittings and valves are (or approved equal):

|                 |              |
|-----------------|--------------|
| Mueller         | Trenton Pipe |
| Ford Meter Box  | Merit Brass  |
| A Y McDonald    | Lee Brass    |
| Cambridge Brass | Milwaukee    |
| Watts           | Kitz         |

**26 05 00 – COMMON WORK RESULTS FOR ELECTRICAL  
SECTION 26 05 19  
LOW-VOLTAGE ELECTRICAL POWER CONDUCTORS AND CABLES**

1. GENERAL

- A. Provision of tracing wire for locating buried PVC pipe.
- B. Related work:
  - a. PVC pipe, Asbestos Cement (AC) pipe, gate valves and key tubes
- C. Submittals:
  - a. Submit manufacture's information showing the tracer wire type, AWG size, insulation color and materials composition and wire materials of construction.

2. PRODUCTS

- A. Tracer wire shall be new, 12 AWG solid THHN copper conductor.
- B. The wire shall be covered with PVC insulation over which a nylon (polyamide) jacket is applied and rated for 600 volts. The insulation and jacket shall be RoHS compliant and utilize virgin grade material.
- C. The insulation color shall be blue for water service to match the APWA color code standard for identification of buried utilities.

3. MANUFACTURERS

- A. The tracer wire shall be Pro-Line Safety Products or approved equal.

**31 25 00 – EROSION & SEDIMENTATION CONTROLS**  
**SECTION 31 25 14.16**  
**ROLLED EROSION CONTROL MATS AND BLANKETS**

1. GENERAL

- A. Provision of geotextile filter fabric for lining of fire hydrant drainage pits.
- B. Related work:
  - 1. Fire Hydrants
- C. Submittals
  - 2. Submit manufacture’s information showing the geotextile fabric type, weight, color and materials of construction.

2. PRODUCTS

- A. The geotextile fabric shall be #200 spun bond polypropylene (i.e., 2 ounces per square yard or 67.7 grams per square meter) with the following characteristics:

| Test            |    | ASTM Method | Unit            | Average | Minimum |
|-----------------|----|-------------|-----------------|---------|---------|
| Material weight |    |             | $\frac{g}{m^2}$ | 68      | 65.5    |
| Tensile Grab    | MD | D5034-09    | lbs.            | 38.5    | 34.6    |
| Grab Elongation | MD | D5034-09    | %               | 118     | 106     |
| Tensile Grab    | CD | D5034-09    | lbs.            | 34.4    | 31      |
| Grab Elongation | CD | D5034-09    | %               | 128     | 115.5   |

- B. The geotextile fabric shall be supplied in 48-inch x 48-inch sheets.

3. MANUFACTURERS

- A. Geotextile filter fabric shall be #200 polypropylene as manufactured by Ovasco Industries or approved equal.

**33 01 00 - OPERATION & MAINTENANCE OF UTILITIES  
 SECTION 33 01 10.54  
 CLEANING OF WATER UTILITY PIPING (POLY PIGS)**

1. GENERAL

- A. Provision of polyurethane foam pipeline cleaners for pigging of the water main prior to placing the main in-service.
- B. Related Work:
  - a. Ductile Iron Pipe and PVC Pipe, Ductile Iron Fittings, Gate Valves
- C. Submittals:
  - a. Submit manufacture’s information showing the pipeline cleaner type, diameter, density, length of nose and length of body, color and materials of construction.

2. PRODUCTS:

- A. Pipeline cleaners shall be new, of medium density (5-8 lbs./c.f.), flexible, and composed of an open cell urethane foam body with high resilience.
- B. The outer coating shall be composed of a tough urethane elastomer coating applied in crisscross bands to enhance cleaning and yield strong resistance to wear yet remain flexible to allow the cleaner to pass through fittings, bends, gate valves and other diameter reductions of up to 65% of the cross-section area of the nominal main.
- C. Pipeline cleaner shall be bullet shaped and have a nose on one end and be blunt on the other end and have crisscross bands and sized for the type of water main being cleaned.
- D. Pipeline cleaners shall be color coded for the type of service intended and for easy identification, e.g., blue for PVC pipeline cleaners and red for ductile iron pipeline cleaners.
- E. The materials that compose the pipeline cleaner shall be food grade compatible.
- F. Pipeline cleaners must have an outside diameter based on the type and size of main to be pigged, in accordance with Table 1 for DR 18 PVC pipe and Table 2 for Pressure Class 350 Ductile Iron pipe.

**Table 1- Poly Pig Sizes for DR 18 PVC Pipe**

| Nominal Pipe Size, in. | AWWA C900 DR 18 PVC I.D, in. | Poly Pig Size, in. |
|------------------------|------------------------------|--------------------|
| 4                      | 4.27                         | 4.55               |
| 6                      | 6.13                         | 6.35               |
| 8                      | 8.04                         | 8.3                |
| 12                     | 11.73                        | 12.05              |

**Table 2- Poly Pig Sizes for PC 350 Ductile Iron Pipe**

| Nominal Pipe Size, in. | Pressure Class 350 Ductile Iron Pipe I.D, in. | Poly Pig Size, in. |
|------------------------|---|--------------------|
| 4                      | 4.3   | 4.55               |
| 6                      | 6.4   | 6.65               |
| 8                      | 8.55  | 8.85               |
| 12                     | 12.64   | 13.05              |
| 16                     | 16.72   | 17.10              |
| 20                     | 20.84   | 21.35              |

3. MANUFACTURERS

- A. Pipeline cleaners shall be Municipal Series Model B4 for DR 18 PVC pipe and Model RX-4 for Ductile Iron pipe as manufactured by Pipeline Pigging Products, Incorporated or approved equal.

**33 05 00 – COMMON WORK RESULTS FOR UTILITIES**  
**SECTION 33 05 07.24**  
**STEEL CASING PIPE**

1. GENERAL

- A. The Casing Pipe shall be shipped on flatbed trucks with end bulkheads on the truck and shall be banded together in a maximum of one layer. Each bundle shall not exceed six lengths of pipe. A non-construction grade 4 x 4 timber shall be placed between each layer and/or bundle. Each 4 x 4 timber shall contain a wood chock at the end of the 4 x 4 placed firmly against the pipe. The wood chock shall be 3 ½ x 3 ½ x 3 ½ triangular in shape.

2. PRODUCTS

- A. The material shall conform to the chemical and mechanical requirements of the latest revision of ASTM A 139 “Electric-Fusion (ARC) Welded Steel Pipe” (NPS 4 and over), unless otherwise stated herein.
- B. The pipe furnished shall be grade B. The steel shall be new and previously unused.
- C. Hydrostatic testing shall not be necessary.
- D. All pipe lengths shall be 20 feet, + or – ½ inch, and shall be beveled at one end (for field welding of circumferential joints) and shall be plain right angle cut at the other end. All burrs at the end of the pipe shall be removed.
- E. The wall thickness at any point shall be within 12.5% of the thickness specified in the “Louisville Water Company Technical Specifications and Standard Drawings for Pipeline Construction 2008”.
- F. Circumference- The outside circumference of the pipe shall not vary more than + or – 1% but not exceeding + or – 3/4” from the nominal outside circumference.
- G. Ovality (Out-of-Roundness) - The pipe diameter within 4.0 in. of ends, shall not vary more than 1% from the specified diameter.
- H. Straightness- All pipe lengths shall be 20-foot in length unless approved by the Project Manager.
- I. All ID obstructions (bead welds, slags, etc.) shall not extend more than 3.32” from the ID face.

## SECTION 33 05 07.24.01 CASING SPACERS

### 1. GENERAL

- A. Casing Spacers shall be utilized to protect pipe from damage caused by being pulled through metal casing pipe and to prevent the bells from sliding and resting on the casing pipe. Refer to "Louisville Water Company Technical Specifications and Standard Drawings for Pipeline Construction 2008" Drawing 1500, Steel Casing Pipe and Casing Runners.

### 2. PRODUCTS

- A. Casing spacers shall provide projections around the entire circumference of the carrier pipe.
- B. Casing spacers shall be in segments for field assembly, without the need for special tools.
- C. Spacer segments shall be secured around the carrier pipe by means other than adhesives.
- D. If Casing spacers contain polymers, the polymer shall contain ultraviolet inhibitors.
- E. Casing spacers shall have a minimum compressive strength of 3000 psi.
- F. Casing spacers shall have impact strength of 1.5 ft-lbs./inch.
- G. Casing spacers shall have a dielectric strength of 800 volts/mil.
- H. Each casing spacer shall have full length, integral skids with a minimum bandwidth of 5" and a runner height of 1.95" – 2.2" for a carrier pipe diameter of 4" through 14".
- I. Each casing spacer shall have full length, integral skids, with a minimum bandwidth of 8" and a runner height of 1.95" – 2.2" for a carrier pipe diameter of 16" through 30".
- J. Casing spacers may utilize varying numbers of same size segments to comprise a wrap, around the entire circumference of the carrier pipe.

### 3. MANUFACTURERS

- A. Prequalified manufacturer are APS, GPT Ranger II, or approved equal.

**SECTION 33 05 09.43  
TAPPING SADDLES**

1. GENERAL

- A. The Louisville Water Company has both PVC and Ductile Iron Pipe installed in the system. The Louisville Water Company has DR14 and DR18 PVC pipe that meets AWWA C900, "Standard for Polyvinyl Chloride (PVC) Pressure Pipe – 4" through 12" for Water." Louisville Water Company infrastructure contains thickness class 54 and Pressure Class 350 Ductile Iron Pipe that meets AWWA C151. Water temperature inside the pipe will vary from 34° Fahrenheit to 90° Fahrenheit. Water pressure rating for pipe shall be: 305 PSI for DR14 PVC Pipe; 350 PSI for Ductile Iron Pipe and 235 PSI for DR18 PVC Pipe. Saddles must withstand the aforementioned service conditions.

2. PRODUCTS

- A. Materials received damaged will be returned at contractor's expense.
- B. The straps for PVC Pipe shall be constructed of type #304 stainless steel or better and flattened to provide a wide bearing surface against the pipe. All saddles shall provide a minimum of two inches total width along the pipe's axis for taps up to one inch in size. Taps 1 ¼" through 2" shall have a minimum of three inches total band width with full circumferential support.
- C. Service Saddles for Ductile Iron Pipe must be constructed with dual bronze straps and having 4 bolts attached with brass unitized nuts and washers in accordance with AWWA C800 & M23. Nuts shall be brass alloy per ASTM B62 and AWWA C800.
- D. The body shall be cast from certified 85-5-5-5 water works brass conforming to the latest edition of ASTM B-62 and AWWA C800.
- E. The rubber gasket shall be EPDM rubber or better and shall conform to the pipe surface and bonded in place for easy installation.

3. MANUFACTURERS

- A. Provided below is a list of prequalified manufacturers for PVC Pipe and Ductile Iron Pipe (or approved equal):

| Pre-qualified Manufacturers | PVC Pipe | Ductile Iron Pipe |
|-----------------------------|----------|-------------------|
| A.Y. McDonald               | 3845     | 3825              |
| Ford Style                  | 202BS    | 202B              |
| Mueller                     | BR2S     | BR2B              |
| SmithBlair                  | 325'S    | 325'S             |

**SECTION 33 05 09.44**  
**TAPPING SLEEVE & GATE VALVE**

1. PRODUCTS

A. TAPPING SLEEVE

1. Tapping Sleeve shall meet the requirements of AWWA C223 and AWWA C500/C509 as applicable to the type of valve specified.
2. Tapping sleeve shall be a high-pressure full circumference band with a flanged (FLG) outlet. Sleeves shall have a rated minimum working pressure of 200 PSI up to and including 10-inch outlets.
3. Sleeve bodies and branches shall be 18-8 stainless steel type 304 per ASTM A240 and fully passivated for maximum corrosion protection. FLG outlets shall be the same stainless steel or ductile iron and joined to the body as one unit.
4. The branch shall contain a 3/4-inch NPT bronze or stainless steel test plug located at the 12 o'clock position, based on length of sleeve (top of sleeve) for release of air during installation and to allow for hydrostatic testing.
5. Gaskets shall provide a full circumferential seal around the body and a hydro-mechanical seal at the outlet seal and be compounded for use with potable water and shall meet or exceed the most recent edition of ASTM D2000.
6. Bolts, heavy hex nuts and washers shall be 18-8 stainless steel type 304 and treated to prevent galling.
7. Sleeves shall be delivered complete with gaskets & accessories. Sleeves must be tagged and marked indicating the size & O.D. ranges.

B. GATE VALVE

1. General Requirements:
  - i. Unless otherwise specified below, these requirements shall apply to all gate valves.
  - ii. Gate valves shall meet the requirements of AWWA C500 and AWWA C509 as applicable to the type of valve specified.
  - iii. Buried and submerged valves shall be furnished with mechanical joints and stainless steel hardware, non-rising stem design.
  - iv. Exposed valves shall be furnished with Class 250 flanged ends; provide valves outside screw and yoke. Exposed valves 16-inch and larger shall be furnished with a valve bypass.
  - v. The valve body, bonnet, and gate castings shall be constructed of ductile iron, and shall have full shell thickness according to AWWA C509, Table 2, Section 4.4.
  - vi. Rising stem valves shall be sealed with adjustable and replaceable packing; valve design must permit packing replacement under operating system pressures with only moderate leakage.
  - vii. Non-rising stem valves shall use double O-ring stem seal, except that packing shall be used where gear operators are required.

- viii. Except as otherwise specified, valves shall be rated for the following working water pressures:

| Valve Size        | Pressure (psig) |
|-------------------|-----------------|
| 3-inch to 20-inch | 250             |

- ix. All valve bodies shall be hydrostatically tested to at least twice the rated working water pressure. In addition, valves shall be seat-tested, bi-directional at the rated working pressure, with a bubble tight seal. Provide certification of testing.
- x. Flanged valves to have face-to-face dimensions per ANSI C115.
- xi. All bonnet and packing gland bolts shall be zinc or cadmium electroplated steel; packing gland bolts shall have bronze nuts.
- xii. All valves shall be marked per AWWA Standards, including name of manufacturer, valve size and working pressure, and year of manufacture.
- xiii. Valve operation shall be open right (turning clockwise). Provide permanent label showing “OPEN” and arrows.
- xiv. Valves shall be suitable for potable water service.
- xv. Gate Valves shall be Type V134 resilient seated ductile iron gate valves manufactured by Mueller, American Flow Control, or equal.
- xvi. Internal and external epoxy of valve body, including bonnet, per AWWA C550.
- xvii. Gate shall be encapsulated with synthetic rubber. It shall be bonded and vulcanized in accordance with ASTM D429 Method B.
- xviii. No recesses in valve body.
- xix. Valves shall be installed as shown on the PROJECT DRAWINGS.

**2. Buried Valve Requirements**

- i. Buried valves shall conform to the requirements above, except mechanical joint bell ends per AWWA C111. All exposed valve hardware (nuts, bolts, washers, etc.) including bonnet, bonnet cover, stuffing box, gear adapter, and joints shall be Type 304 stainless steel.
- ii. Stem shall be non-rising design, double O-ring seals for non-gear valves and shall incorporate packing for geared valves.
- iii. Valve shall be provided with valve box, 2-inch operating nut and extension stem and stem cover, and tee handled valve wrenches.
- iv. All valves that have mechanical joint ends shall have MJ coupled restraint joints.

**SECTION 33 05 19  
 DUCTILE IRON PIPE**

1. GENERAL

- A. Pipe shall be ductile iron and shall be manufactured in accordance with the latest edition of AWWA C150 and C151 and AWWA/ANSI C104/A21.4-Standard for Ductile Iron Pipe, Centrifugally Cast in Metal Molds or Sand-lined Molds, for the water distribution system of the Louisville Water Company. Water temperature inside the pipe will vary from approximately 34° F to 84° F. All pipe shall be furnished with push-on joints as per the latest edition of AWWA/ANSI C151/A21.51, Sec. 51.2.6.

2. PRODUCTS

A. METAL THICKNESS REQUIRED FOR DUCTILE IRON PIPE

| Size | Rated Working Pressure (Meet or Exceed) | Nominal Metal Thickness |
|------|---|-------------------------|
| 4"   | 350                                     | 0.25"                   |
| 6"   | 350                                     | 0.25"                   |
| 8"   | 350                                     | 0.25"                   |
| 10"  | 350                                     | 0.26"                   |
| 12"  | 350                                     | 0.28"                   |
| 14"  | 350                                     | 0.31"                   |
| 16"  | 350                                     | 0.34"                   |
| 20"  | 250                                     | 0.38"                   |
| 24"  | 250                                     | 0.43"                   |
| 30"  | 250                                     | 0.49"                   |
| 36"  | 250                                     | 0.56"                   |
| 48"  | 250                                     | 0.70"                   |

B. SPECIFIC REQUIREMENTS

- 1. Certificate of Compliance: A certificate stating compliance with the latest edition of AWWA/ANSI C104/A21.4 shall be submitted with this bid. Records supporting compliance with the testing procedures and acceptance values established in the standard shall be made available upon request.
- 2. Louisville Water Company reserves the right to have either independent testing or its own employee evaluation present during production to verify compliance to applicable AWWA standards.
- 3. Coating: Pipe shall have an outside asphaltic coating approximately 1 mil thick. The finished coating shall be continuous, smooth, neither brittle when cold nor sticky when exposed to the sun and strongly adherent of the pipe. The inside shall be lined with cement mortar lining and seal coated in accordance with the latest edition of AWWA/ANSI C104/A21.4 – Standard for Cement-Mortar Linings for Ductile Iron Pipe and fittings for Water. Thickness of the cement lining shall not be less than 1/6 inch for 3 to 12 inch pipe, 3/32 inch for 14 to 24 inch pipe and 1/8 inch for 30 to 48 inch pipe. Special attention is directed to strict observance of the requirements in AWWA Standard C104, 4.11, relating to characteristic of asphaltic seal as to

deleterious effects upon quality, color, taste or odor imparted to potable water, leaching resistance and limit of toxic substances.

4. Joints:
  - A. Mechanical and Push-On: Mechanical and push-on joints including accessories shall conform to ANSI/AWWA C111/A21.11.
  - B. Restrained: When restrained joints are required, they shall be boltless push-on type. Boltless restrained joints shall be either U.S. Pipe and Foundry “TR Flex”, American Ductile Iron Pipe “Flex-Ring”, or equal. Restrained joint pipe shall be furnished with a factory welded retaining ring. The use of field installed retaining rings such as “Gripper Rings” and “Field Lock Gaskets” will be permitted for 12” and smaller ductile iron water main only.
5. Marking Pipe: Each length of pipe shall be clearly marked by the manufacturer identifying the name of the manufacturer, year of manufacture, identified as being ductile iron, new weight without lining, pressure rating, metal thickness or nominal thickness, casting period and nominal length of pipe.
6. Type and Class: Pipe shall be of nominal 18 ft. or 20 ft. laying lengths as per the latest edition of AWWA/ANSI C151/A21.51, free of surface defects, especially pitting, with push-on type joints and shall be furnished complete with standard rubber o-ring gaskets meeting the latest edition of AWWA/ANSI C111/A21.11- Standard for Rubber Gasket Joints for Ductile Iron Pressure Pipe and Fittings.

### 3. MANUFACTURERS

- A. Past accepted or used Manufacturers (or Approved Equal):

|                       |        |
|-----------------------|--------|
| US Pipe               | McWane |
| Griffin Pipe          | Clow   |
| American Ductile Iron |        |
7. All others shall submit technical specifications and affidavit of compliance that the pipe meets AWWA specifications as listed and all other Louisville Water Company specifications listed herein.

**SECTION 33 05 19.01  
POLYWRAP FOR WRAPPING DUCTILE IRON**

1. GENERAL

A. POLYETHYLENE WRAP

1. All material supplied shall be free from defects in material and workmanship and shall meet standards as stated in this specification.
2. All polyethylene wrap shall be linear low density, 8 mil thick, Tube-Type.
3. Wrap shall be furnished in rolls appropriate to the project (no scrap pieces), non-perforated.
4. Wrap shall be tinted PMS color 299-C or LWC approved tinted blue color.
5. Product shall be in conformance with the latest edition of AWWA Standard C105/A21.5.
6. Film shall be manufactured of virgin polyethylene materials.
7. A certificate of compliance to all AWWA C105/A21.5 requirements shall be provided by the manufacturer.
8. Approved manufacturers are Hamilton Plastics, Christy's, Champion Plastics, and AA Thread.

**SECTION 33 05 19.02  
POLYTAPE FOR WRAPPING DUCTILE IRON**

1. GENERAL

A. POLYETHYLENE TAPE

1. All material supplied shall be free from defects in material and workmanship and shall meet standards as stated in this specification.
2. The material shall have a polyethylene film backing with the following performance characteristics.
  - (1) Minimum thickness shall be 7 mils.
  - (2) Minimum tensile strength shall be 20 lbs/inch per ASTM D-1000.
  - (3) Adhesion to steel shall be a minimum of 25 oz/inch per PSTC-101.
  - (4) Adhesion to backing shall be a minimum of 25 oz/inch per PSTC-101.
  - (5) Minimum operating temperature shall be no greater than 40 degrees Fahrenheit.
  - (6) Maximum operating temperature shall be no less than 180 degrees Fahrenheit.
3. Tape shall be minimum 1.89 inches in width and yellow in color.
4. Tape shall be Polyken 809 as manufactured by Berry Global Inc. or equal.

## SECTION 33 05 31.16 PVC PIPE

### 1. GENERAL

- A. The pipe supplied shall be Polyvinyl Chloride Pipe, cast iron O.D. base design, blue in color and manufactured in accordance with the latest edition of ANSI/AWWA C900, "AWWA standard for underground installation of Polyvinyl Chloride (PVC) Pressure Pipe and fabricated fittings, 4" through 12" for water distribution." This pipe is intended for use as municipal water pipe in the potable water distribution system of Louisville Water Company.

### 2. PRODUCTS

#### A. Certifications:

1. The manufacturer of the pipe furnished under these specifications must be listed by the Underwriters Laboratory, be approved by the Factory Mutual System and in compliance with the National Sanitation Foundation (NSF) standard number 61.
2. Certification of compliance with the latest edition of AWWA C900 with the testing procedures and acceptance values established in the standard shall be made available upon request. Each length of pipe, including the integral bell, shall be pressure tested to two times the AWWA rated pressure for a minimum of five (5) seconds.
3. Louisville Water Company reserves the right to have independent testing or an its own representative evaluation present during production to verify compliance to referenced AWWA standards.

#### B. Type and Class:

1. Pipe shall be of nominal 20' laying lengths. Exclusions are taken to the AWWA allowance of random lengths, length variance shall be  $\pm 1$  inch. Pipe shall have gasket bell end type joints and shall be furnished complete with gaskets in place, meeting the latest revision to ASTM F477, "Elastomeric Seals for Joining Plastic Pipe".

#### C. Markings:

1. Pipe shall bear identification markings that will remain legible during normal handling, storage, and installation. The markings shall be prescribed by AWWA Standards applied in a manner that will not reduce the strength of the pipe or otherwise damage it. The tapered end of the pipe shall have a fully-seated line encircling its circumference. Additional markings on the pipe shall include the following and shall be applied at intervals of not more than five feet:
  - a. Nominal size (for example, 4 in.)
  - b. PVC
  - c. Dimension Ratio (DR)
  - d. AWWA pressure class
  - e. AWWA designation number for this standard
  - f. Manufacture's name or trademark and production record code, including year of manufacture
  - g. Seal (mark) of the testing agency that verified the suitability of the pipe material for potable water service.

D. Bevel Requirements:

1. Factory-finished spigot ends must have a minimum level of 15 degrees to a maximum bevel of 22.5 degrees. The vertical face of the spigot end may not exceed 75% of pipe wall thickness and the horizontal length of the bevel shall not exceed 1.25".

3. MANUFACTURERS

A. PVC water main shall be manufactured by (or approved equal):

|                |                        |
|----------------|------------------------|
| North American | Certainteed            |
| Sanderson      | Diamond Plastics Royal |
| Vulcan         | National Pipe          |
| Vinylplex      |                        |

**SECTION 33 05 31.26**  
**SERVICE SLEEVES**

1. GENERAL

- A. Provision of SERVICE SLEEVE for installing water service line 2-inch and smaller.  
Service sleeve shall be used as a casing pipe installed prior to the installation of paved roads for the future service line (carrier pipe).

2. PRODUCTS

- A. Service sleeve shall be new Schedule 40 PVC pipe with a minimum 2-inch inside diameter.
- B. Schedule 40 PVC pipe shall be made in accordance to ASTM 1785 and ASTM 2466.
- C. Schedule 40 PVC pipe shall be gray in color.
- D. Schedule 40 PVC pipe shall be IPS.
- E. Schedule 40 PVC pipe shall be supplied in 20-ft length

**SECTION 33 05 73**  
**VALVE BOXES, LIDS, & RISERS**

1. PRODUCTS

A. LWC Valve Boxes

- i. LWC Valve boxes are a unit and shall be delivered as a valve box set.
- ii. The units must conform to the enclosed drawings.
- iii. Contractor will be required to create molds for the valve boxes.
- iv. The casting shall be cast iron conforming to the latest editions of ANSI/AWWA A21.10/C110; ASTM 126, Class B; or ASTM A48, Class 30.
- v. The casting shall be uniform, smooth and free of burrs, spurs and cracks.
- vi. The thickness and dimensions shall conform to the attached drawings.
- vii. The coating for general use under normal conditions shall be a petroleum-asphaltic coating approximately 1 mil thick. The coating shall be applied to the entire external portions of the unit.
- viii. The finished coating shall be continuous, smooth, neither brittle when cold nor sticky when exposed to the sun and strongly adherent to the casting.
- ix. The weight of each complete unit shall be a minimum of seventy (70) pounds.
- x. Drawings are included in the bid package for clarification and measurement purposes. All units must conform to the enclosed drawings.

B. County 5 ¼-inch Valve Box Lids & Risers

- i. The Lids and Risers furnished under this bid must be interchangeable with the Tyler Union
- ii. Two Piece 5 ¼" shaft valve boxes marked "Water".
- iii. The casting shall be cast iron conforming to the latest editions of ANSI/AWWA A21.10/C110; ASTM 126, Class B; or ASTM A48, Class 30.
- iv. The casting shall be uniform, smooth and free of burrs, spurs and cracks.
- v. The coating for general use under normal conditions shall be a petroleum-asphaltic coating approximately 1 mil thick. The coating shall be applied to the entire external portions of the unit.
- vi. The finished coating shall be continuous, smooth, neither brittle when cold nor sticky when exposed to the sun and strongly adherent to the casting.

2. MANUFACTURERS

- A. Preapproved manufacturers for LWC Valve Boxes are Sigma Corporation, Russell Pipe or General Foundries.
- B. Preapproved manufacturers for County 5 ¼" Valve Box Lids & Risers are Sigma Corporation, Russell Pipe, Star Pipe, Tyler Union or General Foundries.

**SECTION 33 05 73.01  
PLASTIC METER VAULTS & EXTENSION RINGS**

1. PRODUCTS

- A. Meter vaults and elevator rings shall be designed to support a vertical 20,000 pound axial load equally distributed around the rim while freestanding (without horizontal support) on a flat surface with a maximum deflection of less than or equal to 0.5 inches.
- B. The vaults shall be designed to a minimum pipe stiffness of four (4) PSI. The pipe stiffness shall be tested in accordance with ASTM D2412.
- C. Meter vaults shall not develop environmental stress cracking or be subject to deformation, sagging, or degradation in any manner while in storage or in underground applications.
- D. Meter vaults shall be resistant to moisture and both acid and alkaline conditions.
- E. Meter vaults shall be suitable to be stored outside and withstand ultra violet (U.V.) radiation and all weather conditions with temperatures ranging from -30° (degrees) to 140° (degrees) Fahrenheit.
- F. The small meter vault weight shall not exceed 50 lbs. and the large meter vault weight shall not exceed 80 lbs. Meter vaults shall not be corrugated.
- G. The small meter vault shall have an inside diameter range of 19.50" to 20.30" at the top of the vault and shall be 19.0" on the bottom of the vault.
- H. The large meter vault shall have an inside diameter range of 35.50" to 36.25".
- I. Manufacturer's data showing inside diameter, outside diameter, length, pipe stiffness (testing according to ASTM D2412), section modules, vertical load carried at 0.25 inch deflection of pipe shall be provided upon request. Certified test data showing compliance with the strength requirements of this specification shall be provided upon request.
- J. The interior surface area shall be of white color for reflective purposes.
- K. There shall be 2 mouse holes measuring 3" wide X 4" tall 180 degrees opposite each other at bottom of vault.
- L. Elevator rings must be compatible with the manufacturer's own vault and with pre-qualified manufacturer's vaults listed.
- M. Sizes of elevator rings for the 20 x 36 vault shall be 4", 6", 8". A 22-degree sloped model shall also be provided. The size provided for the 36 x 36 vault shall be 3".
- N. Average Thermal Resistance "R" per specimen thickness shall be no less than 0.150 (Hr.ft<sup>2</sup>.degF)/BTU.

2. MANUFACTURERS

- A. The following are Pre-qualified:
  - i. Oldcastle Precast: Item #00202032, body HW0020-36 Blk/Wht, 2MH, SW, LVILLE
  - ii. Oldcastle Precast: Item #00362003 0036-36 B Body B-W 2 MsHI
  - iii. Bingham & Taylor: Item # MMP2036 – Diameter 20-inch, Depth 36-inch
  - iv. Bingham & Taylor: Item # PMP3636 – Diameter 36-inch, Depth 36-inch

## SECTION 33 05 73.02 METER SETTERS

### 1. GENERAL

- A. The 1 1/2-inch and 2-inch Meter Setters with 1-inch bypass to be furnished shall be manufactured in accordance with these specifications and the standards of the water service industry for potable water service installation.
- B. The setter assemblies shall have dimensions in compliance with the attached drawings.
- C. These setters shall be utilized in the potable water distribution system of Louisville Water Company; water temperature will vary from 34 · F to 90 · F, with a maximum working water pressure of 125 psi.

### 2. PRODUCTS

#### A. General Assembly and Shipment

- 1. Copper Tubing: The copper tubing shall be soft copper, Type K in all sizes and shall conform to the latest edition of AWWA C800 A.2, ASTM B88 and B88M.
- 2. Fittings: The fittings shall be in accordance with the latest edition of AWWA C800 and ASTM B88 with joints as described in the attached drawing (see pages DR-1 and DR-2).
- 3. Solder connections shall be lead-free and suitable for standard copper tubing.
- 4. Threaded connections shall be standard iron pipe threads.
- 5. Meter flanges shall be standard 1 ½ and 2-inch with support brackets and contain either EPDM or better rubber gaskets with 5/8-inch holes in wings for meter bolts.
- 6. Meter assembly bottom support spreaders shall be copper.
- 7. Each setter shall be packaged complete with all components and gaskets and shall be partially assembled into the following components:

#### (1) 1½-INCH METER SETTER

- (a) Two (2) 90° ell with yoke bar and eye (1 1/2 -inch solder x 1 1/2 -inch male thread with female compression coupling)
- (b) Four (4) adapters (1 1/2 -inch solder x 1 1/2 -inch male thread or compression)
- (c) Two (2) tees (1 1/2—inch x 1 1/2-inch x 1-inch thread)
- (d) One (1) 1 1/2 -inch angle meter valve with padlock wings on inverted key and support brackets on meter flange (1 ½ female thread on 1 ½ meter flange).
- (e) One (1) 1 1/2 -inch angle check valve with support brackets on meter flange (1 1/2 -inch female thread on 1 1/2-inch meter flange).
- (f) Two (2) 1-inch angle meter valves on bypass with padlock wings on inverted key and a 1-inch meter coupling nut (1 -inch female thread x 1 -inch female thread).
- (g) Four (4) adapters on bypass (1-inch male thread x 1-inch solder).

#### (2) 2-INCH METER SETTER

- (a) Two (2) 90° ell with yoke bar and eye (2-inch solder x 2-inch male thread with female compression coupling).
- (b) Four (4) adapters (2-inch solder x 2-inch male thread or compression).
- (c) Two (2) tees (2-inch x 2-inch x 1-inch thread)
- (d) One (1) 2-inch angle meter valve with padlock wings on inverted key and support brackets on meter flange (female thread on meter flange).
- (e) One (1) 2-inch angle check valve with support brackets on meter flange (female thread on meter flange).

- (f) Two (2) 1-inch angle meter valves on bypass with padlock wings on inverted key and a 1-inch meter coupling nut (1-inch female thread x 1-inch female thread).
- (g) Four (4) adapters on bypass (1-inch male thread x 1-inch solder).

### 3. MANUFACTURERS

A. The following are pre-qualified models. All other models must be pre-approved by the Project Manager.

- 1. 1-1/2-inch Meter Setter
  - (1) Ford VFH 66
  - (2) A.Y. McDonald 20R621WDFE 664
  - (3) Mueller
  
- 2. 2-inch Meter Setter
  - (1) Ford VFH 77
  - (2) A.Y. McDonald 20R721WDFE 774
  - (3) Mueller

### SECTION 33 05 73.03 PIPE REPAIR SLEEVES

#### 1. GENERAL

- A. Stainless Steel Bands - Shall be of flexible stainless steel. Consist of one or more sections. Made of #304 stainless steel per ASTM A240, minimum 20 gauge. Bands shall have applicable outside diameter (O.D.) ranges adhered to the band in the form of a stamp or label, for easy identification.

#### 2. PRODUCTS

- A. Lugs - Shall be made of high-strength ductile iron. Designed so there is no interference between lug fingers and wrench room used to tighten the nuts.
- B. Bolts and Nuts - Shall be #304 stainless steel with rolled NC threads and treated to prevent galling. Nuts shall be #304 stainless steel, heavy hexagon head.
- C. Bolt Length - On the 4, 6 and 8 inch sleeves, the center bolt shall be 1 ½ inch longer than the standard 6 7/8 inches (shall be minimum of 8 3/8 inch). On the larger sleeves, the center bolt shall be 2 inches longer than the standard 7 inches (shall be a minimum of 9 inches).
- D. Gaskets - Shall be engineered of a rubber compound suitable for potable water. Must be gridded and overlapping to ensure adequate seal. Must meet or exceed ASTM D2000. Must be free of excessive adhesive, which could interfere with the seal.
- E. Band Lengths - Sleeves 12 inch and smaller shall be single band not less than 12 inches in length, with a five (5) bolt lug pattern. Sleeves 16 inch shall be double band and not be less than fifteen (15) inches in length with a six (6) bolt lug pattern. Sleeves 20 inch and larger shall be double band not less than 24 inches in length, with a ten (10) bolt lug pattern.

**SECTION 33 05 73.04**  
**FRAMES, RISERS, AND MONITOR CASTINGS**

1. GENERAL

- A. All castings for water meter vaults shall be iron-cast gray iron per ASTM A48, Class 25 or ductile iron with a minimum tensile strength of 25,000 pounds.
- B. All castings shall be painted with one coat of black asphaltic material, or electrostatically applied epoxy paint. The finished coating shall be continuous, smooth, neither brittle when cold nor sticky when exposed to the sun and shall be strongly adherent to the casting.
- C. Monitor castings shall consist of a flange and ring.
- D. Hooks, bolts, and nuts for elevator/ riser rings for J-hook style shall be brass or bronze and installed in the frames prior to delivery. Hooks must be capable of bending to a minimum deflection of 90 degrees in any direction without breaking or cracking.
- E. Hex-head bolts and nuts for risers shall be carbon steel and meet ASTM 325 Type 1.

2. PRODUCTS

A. Workmanship

- 1. Inside lip of the frame must be void free with a clean, uniform, smooth, machined like finish.
- 2. The surface of the casting shall be free of adhering sand, scale, cracks, and hot tears as determined by visual inspections.
- 3. No repairing by plugging and welding will be accepted.
- 4. All frames shall be smooth and free of burrs and sharp edges.

B. Dimensions

- 1. Dimensions shall be in accordance with the attached drawings 5102, 5103, 5103B, 5104, 5105, and 5106. A tolerance of 1/16" will be allowable on all physical dimensions except brass hook anchor hole with a 1/32" + only (not less) on risers.

C. Performance Standards

- 1. Small frames (light) must be interchangeable with Ford Meter Box Co., model C3.
- 2. Small frames (heavy) must be interchangeable with Ford Meter Box model C3H.
- 3. Risers furnished under this bid shall work with Ford Meter Box Co. small frames model C3, C3H, Meter Box Covers MC-36, and Bingham and Taylor's BTC-3 and BTC-3H.
- 4. Risers for monitor castings shall work with Ford Meter Box model RR-11.
- 5. Monitor rings must be interchangeable with Ford Meter Box model RR-11.
- 6. A minimum weight load capacity certification shall be provided from an independent engineering testing company (written in English). Materials shall be capable of withstanding a minimum weight load capacity in accordance with AASHTO M306 testing standards. The proof loads shall be 20,000 pounds for heavy frames, monitor castings, and elevator/riser rings and 7,500 pounds for light frames.
- 7. Failure to meet minimum proof loads listed will be cause for immediate rejection.

3. MANUFACTURES

A. The castings shall be from the following manufacturers or approved equal:

- Ford Meter Box
- General Foundries
- Bingham and Taylor
- Vestal Industries

## SECTION 33 05 81 ALUMINUM HATCHES

### 1. PRODUCTS

- A. Hatch shall have an H-20 load capacity to handle vehicular traffic.
- B. Hatch channel frame and door panel must be made of 1/4" aluminum diamond plate.
- C. Hatch channel frame must be 6" in depth to mount flush, top and bottom, when installing a 6" concrete slab top.
- D. Hatch must be equipped with a #304 stainless steel hold open arm and release mechanism to secure the door once it is opened.
- E. Top of hatch door must close flush with the top of the frame.
- F. Hatch door must open at 90° (degrees).
- G. All hinges and fastening hardware shall be #304 stainless steel.
- H. Unit shall lock using a #304 stainless steel slam lock with removable key wrench that will be provided with each hatch.
- I. Hatch shall have a 1 1/2" drain hole located inside the channel frame. Any re-enforcement shall not protrude outside of the exterior rectangular frame.
- J. Hatch shall come equipped with a #304 stainless steel compression spring to counter balance the door weight and resist downward pressure while being closed.
- K. Hatch shall come equipped with a recessed #304 stainless steel or better handle to assist in opening and closing the door. The top of the handle shall be recessed a minimum of 1/2" below the top surface of the hatch.
- L. Louisville Water Company standard frame opening size will be 30" x 36".
- M. Hatch Lid shall have four (4) spaces with 4" diameter clearance from any re-enforcement to allow four (4) holes to be drilled by others, of 4" in diameter at locations determined by the manufacturer. Locations shall not interfere with the loading design capacity.

### 2. MANUFACTURES

- A. The hatches shall be from the following manufacturers or approved equal:
  - USF Fabrication
  - EJ USA
  - Cierra/Babcock-Davis
  - Halliday

**40 05 00 - COMMON WORK RESULTS FOR PROCESS INTERCONNECTIONS**  
**SECTION 40 05 17**  
**COPPER TUBING**

1. PRODUCTS

- A. A Purchase Order number must appear on all bills of lading and invoices.
- B. Copper shall be Type K soft, free from defects, pinholes, kinks, and shall be rounded.
- C. The material supplied shall be in conformance with the latest edition of the AWWA C800 Standard, ASTM B88 and B88M.

2. MANUFACTURERS

- A. The prequalified manufactures are as follows or approved equal:
  - 1. Cerro
  - 2. Mueller
  - 3. Weiland
  - 4. Howell
  - 5. Great Lakes

## SECTION 40 05 61.23 SWING CHECK VALVES

### 1. GENERAL

- A. The swing check valves shall have a cast iron or ductile iron body and cover. The cast iron shall equal or exceed the requirements of ASTM A-126, Class B with a tensile strength greater than 31,000 PSI. Ductile iron shall conform to ASTM A-395 or ASTM A-536.

### 2. PRODUCTS

- A. Swing check valves must be certified for use in drinking water in accordance with NSF/ANSI 61 and are Certified Lead-Free per NSF/ANSI 372. Every valve is to be tested in accordance with and is certified to AWWA C508.
- B. The valve shall have a ductile iron or stainless steel clapper disc certified for use in drinking water in accordance with NSF/ANSI 61 and are Certified Lead-Free per NSF/ANSI 372. The clapper shall open fully to provide a net flow not less than the nominal pipe area. The disc shall bear against a stop in the full open position located to withstand impact or flow pressure which might damage the disc and related parts.
- C. The clapper disc shall have a composition disc seating surface of EPDM rubber or better, conforming to the requirements of AWWA C508.
- D. The hinge pin shall be of stainless steel and provide free rotation of the clapper disc.
- E. The machined seat ring shall screw into the valve body and provide a uniform seating surface for the clapper.
- F. All internal parts shall be readily accessible through the valve cover.
- G. Cover and flange nuts and bolts shall be type #304 stainless steel.
- H. Cover and flange gaskets shall be EPDM or BUNA-N rubber, 1/8 inch thick and of uniform dimensions, conforming to the requirements of AWWA C508.
- I. The ends shall be flanged and shall conform in dimensions and drilling to ANSI B16.1, Class 125.
- J. The valves shall conform to all applicable requirements of AWWA C508, "Standard for Swing Check Valves for Waterworks Service, 2 inch through 24 inch NPS and NSF/ANSI 61 and are Certified Lead-Free per NSF/ANSI 372."
- K. The coating furnished shall be suitable for potable water service and shall conform to AWWA C550, "Protective Internal Coatings for Valves and Hydrants."
- L. All internal and external surfaces except finished or bearing surfaces shall be shop cleaned and coated in accordance with this specification and applicable Steel Structures Painting Council specifications (SSPC).
- M. The surface shall be free of irregularities, burrs and sharp or rough edges prior to the application of the coating.
- N. Surface preparations for fusion bonded epoxy coating system shall conform with SSPC SP10, "White Metal Blast Cleaning." The fusion bonded epoxy coating shall be suitable for ferrous and non-ferrous metals subject to chemical corrosion and/or physical abrasion. Preheat and cure requirements of the manufacturer shall be observed. Dry powder shall be spray applied uniformly to achieve a minimum final dry film thickness of 8 mils.
- O. The selected coating system specifications shall be submitted for approval. A light clear color shall be used to enhance inspection.
- P. All swing check valves shall be guaranteed against defects in materials and workmanship for a period of one (1) year from date of shipment. Parts to replace those in which a defect has developed within such period will be supplied without charge, piece for piece, upon proper proof of defect.
- Q. Swing check valves shall be guaranteed to operate under a working pressure of 150 PSI, without leakage or damage to any parts. Valves shall be factory tested at 350 PSI.

- R. The valve body and cover shall be hydrostatically tested to withstand 350 PSI. No leakage through the body joints shall occur for one (1) minute.
- S. Seat and disc closure shall be hydrostatically tested to withstand 175 PSI differential pressure against the outlet end. Maximum permissible leakage shall be one (1) fluid ounce per hour per inch of nominal valve size.
- T. The valve casting shall have cast markings or a permanently affixed nameplate identifying the manufacturer, valve size, working pressure, flow directions (arrow) and year of manufacture.

**SECTION 40 05 61.24  
 FLAT FACED FLANGED SPOOL PIECES**

1. GENERAL

- A. All steel pipe and fittings listed in Section 2 Paragraph A1 and Section 3 Paragraph A, below shall conform to the requirements of the latest editions of the following AWWA specifications:

|             |  |
|-------------|--|
| C-800- C200 | Steel water pipe 6” and larger   |
| C-207       | Steel pipe flanges   |
| C-210       | Liquid epoxy coating systems for interior and exterior of steel water pipelines. |

2. PRODUCTS

- A. All Spool pieces must have flat faced flanges.
- B. Description – Large Meter By-Pass and Test Spools  
 Steel flanged spool with one (1) 2” female Standard Iron Pipe (FIP)) threaded steel outlet. (Weldolets) Outlets will be installed between flanged eyelets to allow suitable clearance so that nuts and bolts may be inserted through the flanges.

Nominal Lengths

| Nominal Size | Length   |
|--------------|----------|
| 3 Inch       | 7 Inch   |
| 4 Inch       | 7 Inch   |
| 6 Inch       | 7 ½ Inch |
| 8 Inch       | 8 Inch   |

- C. Description- Large Meter By-Pass Spools  
 Steel flanged spool with two (2) 2” female Standard Iron Pipe (FIP) threaded Steel outlet. (Weldolets) Outlets will be installed between flanged eyelets to allow suitable clearance so that nuts and bolts may be inserted through the flanges. Outlets shall be spaced 180<sup>0</sup> apart.

Nominal Lengths

| D. Nominal<br>E. Size | Length   |
|-----------------------|----------|
| F. 3 Inch             | 7 Inch   |
| G. 4 Inch             | 7 Inch   |
| H. 6 Inch             | 7 ½ Inch |
| I. 8 Inch             | 8 Inch   |

D. Pipe

Pipe shall be Schedule 40 black and shall meet or exceed the latest edition of AWWA standards as follows:

|      |       |               |
|------|-------|---------------|
| AWWA | C-200 | Steel Pipe    |
| ASTM | A120  | Welded Steel  |
| AWWA | C-800 | Service Lines |

E. Preparations of the Ends

The ends shall be plain end and fitted with flat faced flanges and shall conform to and tested with the latest edition of AWWA Standard C-200 “Steel Water Pipe”.

Steel Weldolet With Female Standard Iron Pipe Thread (FIP)

|                              |  |
|------------------------------|--|
| <b>Schedule</b>              | 40   |
| <b>End Preparations</b>      | Threaded Female Outlets                                      |
| <b>Strength Requirements</b> | Conform to latest editions of ANSI B16.9, B16.11, ASTM A-105 |

F. Flanges

1. Flanges shall be flat faced AWWA Standard steel hub slip-on conforming with the latest edition of AWWA Standard C-207 – “Steel Pipe Flanges For Water Works Service – Sizes 4 inch through 144 inch”.
2. Materials shall conform to the latest edition of AWWA Standard C-207, Section 4.
3. The dimensions and drilling shall conform with the latest edition of AWWA Standard C-207, Table 3, Class D.

G. Coating

1. The coating shall be high solid epoxy coating/Porter coating #7536 or equal and must conform to the latest edition of AWWA C-210 “Liquid Epoxy Coating Systems for the Interior and Exterior of Steel Water Pipelines” and must be EPA approved for potable water linings.
2. The application instructions shall be in strict adherence with manufacturer’s instructions and the latest edition of AWWA Standard C-210.
3. Surface preparations shall be performed and all mill scale shall be removed prior to the application of the coating.
4. Two (2) coats shall be applied and the finished coating shall be free of holidays and pinholes and have a minimal dry film thickness of 10 to 12 mils.
5. Threaded flanges shall be cleaned and with no obstruction to the threads.

H. Attachment of Weldolet

1. The pipe of depth and tap drill size shall be in compliance with the attached sheet Standard Drawing #9004 Weldolet Fitting.
2. The weld fillet shall conform to the latest edition of AWWA Standard C-200, "Steel Water Pipe".

I. Welded Joints

1. The manufacturer shall be responsible for the quality of all work performed by his organization and meet the latest edition of the standard qualification procedure of the American Welding Society and the latest edition of AWWA C-207.

J. Handling

1. Handling and shipping shall be in compliance with the latest edition of AWWA C-200, "Steel Water Pipe".
2. Finished spools shall be stacked on pallets with sufficient spacers or pads to prevent damage to the spool pieces and/or the coatings.
3. Spool pieces showing chips or abrasions will be rejected. The contractor at his expense shall replace or recondition each rejected section.

**SECTION 40 05 61.25**  
**MJ RESTRAINED JOINT ADAPTERS**

1. GENERAL

- A. A compact, bolt through, Mechanical Joint (MJ) Restrained Adapter designed to connect MJ valves to MJ fittings, or MJ fittings to other MJ fittings at a linear distance not to exceed one and one-half inches shall be provided. The design of the restraint shall be such that it can replace the piece of pipe commonly needed to join an MJ fitting to another MJ fitting or valve. The restraint shall be designed to eliminate the need for MJ glands and rubbers.

2. PRODUCTS

- A. Restrained Adapter shall be an integral casting, i.e. no welds and made of ductile iron conforming to ASTM A80-55-06 and rated at 350 psi
- B. Restrained Adapter shall be supplied with NSF 61, 5-mil fusion bonded epoxy coating conforming to AWWA C116/A21.16-09 as well as the coating, surface preparation and application requirements of ANSI/ AWWA C550.
- C. The same design of Restrained Adapter shall be available in sizes 4" to 20". Restrained Adapter and accessories (MJ gaskets, nuts and bolts) shall be packaged in one (1) box.
- D. Mechanical Joint gasket shall be Styrene Butadine Rubber (SBR) or approved equal.
- E. Bolts shall be weathering steel (Corten). Nuts shall be SAE Grade 2 steel with black oxide coating. For restraint sizes 4" to 8", bolt length shall be 5". For restraint size 12" to 20", bolt length shall be 6".

3. MANUFACTURERS

- A. Restrained Joint Adapters shall be Star Pipe Series 100 MJ, Foster Adapter by In Fact, or approved equal.

**SECTION 40 05 61.26  
BELL JOINT CLAMPS**

1. PRODUCTS

- A. The joint clamp must be designed to fit pipe and fittings with a spigot end OD range of 50.3 to 51.98 inches and with a bell face height up to 5.00 inches.
- B. The joint clamp design must fit and function properly on all classes of both the Dennis Long Company and AWWA standard PIT cast iron pipe, as well as American Standard specifications (ASA) for lead joint cast iron pipe and fittings.
- C. Joint clamps shall have a working pressure rating of 150 psi minimum.
- D. Clamps must be ductile iron and shall have asphaltic coating of approximately 1 mil thick. All bolts must be low alloy Cor-ten and all thread.
- E. Rubber gaskets must not require additional fasteners or restraints to remain securely attached to clamps during assembly. Gaskets shall be made from NBR or EPDM.
- F. Each Bell Joint Clamp provided by the manufacturer shall be packaged and contain all the necessary parts and materials required to install the bell joint clamp on the pipe.
- G. Hex head bolts shall be 1 3/4" - 2" wrench size and be able to accommodate standard air/impact tools and sockets for these sizes. Hex head nuts shall be 1 3/4" wrench size and be able to accommodate standard air/impact tools and sockets for this size. In no case shall the head thickness of a bolt or nut compromise LWC's ability to fasten and tighten bolts for the clamps using impact sockets tools.
- H. The joint clamp shall allow reasonable room for impact socket thickness to ensure standard air impact tools can easily access bolts and nuts on clamps, in a manner that allows standard air/impact tools to assemble, disassemble, tighten or loosen bell joints clamps.
- I. The joint clamp shall be NSF 61 certified.
- J. Clamp shall include the following standard items:
  - a. Standard Hook Assembly
  - b. Body Segment
  - c. Shoe
  - d. Gasket

2. MANUFACTURERS

- A. Clamp shall be proportionally designed for 48" pipe and supplied as Romac bell joint leak clamp 416 BJLC or approved equal.

**SECTION 40 05 61.27**  
**DUCTILE IRON PIPE RESTRAINED JOINT GASKETS**

1. GENERAL

- A. The restrained joint gaskets shall be designed for use on Louisville Water Company ductile iron pipe meeting the specifications herein "33 05 19 Ductile Iron Pipe".

2. PRODUCTS

- A. The gaskets shall be used in pressurized ductile iron to prevent the joints from separating due to thrust forces.
- B. The gaskets shall be pressure rated to the pressure class of the pipe and fittings. Restrained joint gaskets for pipe 4" to 24" shall have a minimum pressure rating of 250 PSI.
- C. The gaskets shall conform to the latest edition of the AWWA/ANSI C111/A21.11.
- D. The rubber shall be made of EPDM or SBR.

**SECTION 40 05 61.28**  
**RESTRAINT JOINT CLAMPS**

1. GENERAL

- A. Mechanical joint restraint shall include a restraining mechanism which, when actuated, imparts wedging against the entire circumference of the pipe, increasing its resistance as the pressure increases. Mechanical joint restraints utilizing set screws are not approved for sizes 4" to 12".

2. PRODUCTS

- A. Glands shall be manufactured of ductile iron conforming to the latest edition of ASTM A536.
- B. Restraining devices shall be of ductile iron heat treated to a minimum hardness of 370 BHN. They shall have a working pressure of at least 250 PSI with a minimum safety factor of 2:1.
- C. Dimensions of the gland shall be such that it can be used with the standardized mechanical joint bell and tee-head bolts, conforming to the latest editions of ANSI/AWWA A21.11 and C153/A21.53.
- D. Restraint joint clamps from 4" to 12" shall fit both PVC and Ductile Iron Pipe.
- E. Restraint joint clamps from 16" or larger shall fit only Ductile Iron pipe.
- F. Mechanical joint restraint shall include a restraining mechanism which, when actuated, imparts wedging against the pipe, increasing its resistance as the pressure increases.

3. MANUFACTURERS

- A. Prequalified manufactures for Restraint Joint Clamps (or approved equal) are:
  - (1) Romac
  - (2) Star
  - (3) Ford grip rings (for Ductile Iron Pipe 4"-24")
  - (4) Ebba Iron
  - (5) Sigma

## SECTION 40 05 61.29 DUCTILE IRON FITTINGS

### 1. GENERAL

#### A. Submit shop drawings

1. Include all fittings, bends, outlets, restrained joints, tees, special deflection bells, adapters, solid sleeves and specials.
2. Include manufacturer's drawings and specifications providing complete details of all items.
3. All other pertinent information for all items to be furnished; product data to show compliance of all couplings, supports, fittings, coatings and related items.

#### B. Submit the name of the fitting suppliers.

#### C. Submit Catalog cuts and installation instructions for boltless restrained joint pipe, and mechanically restrained and flanged connections to valves and fittings.

#### D. If mechanical coupling system is used, submit piping, fittings, and appurtenant items which will be utilized to meet system requirements.

#### E. Submit Certification that all bolts to be furnished conform to referenced standards.

#### F. Submit information on all warranties.

### 2. PRODUCTS

#### A. Fittings

##### 1. General

(1) Pipe fittings shall be ductile iron and meet the requirements of ANSI/AWWA C110/A21.10 or AWWA C153/A21.53.

(2) Fittings shall have the same pressure rating, as a minimum, of the connecting pipe. Minimum pressure rating is 350psi for 20-inch diameter and smaller.

(3) Fittings shall be provided with the same joints and couplings that match the pipe restraining method.

##### (a) Push On Joints

(i) Mechanical Joint Fittings (and Valves)

(ii) 4"-12" Utilize Romac Gripper Glands or Bolt-Through Restraint (e.g. Foster Adapters)

(iii) 16"-20" Utilize EBAA Iron MegaLug

##### (b) Boltless Restrained Joints

(i) 20" and Smaller: Mechanical Joint Fittings, or Boltless Restrained Fittings (same manufacturer as pipe), or Friction type restrained glands such as Megalug, or Mechanical Joint Coupled End Joint

(ii) For >20": Boltless Restrained Fittings (same manufacturer as pipe). The use of friction type restrained joints such as Megalugs shall not be allowed for piping greater than 20-inch diameter. Valves may be either Boltless Restrained or Mechanical Joint Coupled End Joint with 316 stainless steel bolts.

##### (c) Flanged Joints = AWWA Flanged Joint Fittings

(4) Closures shall be made with restrained mechanical joint ductile iron solid sleeves.

#### B. Couplings

##### 1. General

(1) Couplings shall meet and be similar to pipeline restraining system.

(2) Couplings shall be manufactured for potable water use using standard materials meeting NSF 61 and 372 and AWWA standards.

(3) Provide restraining tabs, eyelets or the like where necessary.

(4) Couplings shall be from reputable potable water manufactures such as EBAA Iron, Romac, Smith-Blair, Krausz, Dresser, and Ford Meter Box.

##### 2. Restrained Flange Adapters

(1) Ductile Iron – ASTM A536, Grade 65-45-12

(2) Flanged – ASME/ANSI B16.1, Class 125; match pipe system

- (3) Allowable joint deflection of 5-degrees
  - (4) Fully restrained with tie-rods/gussets to limit movement after installation
  - (5) Minimum of six (6) restraining T-bolts and nuts made of high strength low alloy steel, coarse thread meeting AWWA C111.
  - (6) Wedges acceptable; No set-screws allowed
  - (7) Fusion-bonded NSF 61 epoxy coating, interior and exterior
  - (8) Romac Restrained Flanged Coupling Adapter (RFCA), Smith Blair Style 911/912 Flange-Lock Restrained FCA, Dresser Style 127 (restrained), or approved equal
3. Restrained Dismantling Joint
    - (1) Compatible with flanged fittings
    - (2) Adjustable length of at least 2.5 inches
    - (3) Allowable deflection of a minimum of 1.5 degrees
    - (4) Ductile Iron – ASTM A536, Grade 65-45-12
    - (5) Flanged – ASME/ANSI B16.1, Class 125; match pipe system
    - (6) Restrained with tie-rods to limit movement after installation
    - (7) Minimum of four (4) restraining T-bolts and nuts made of high strength low alloy steel, coarse thread meeting AWWA C111.
    - (8) Fusion-bonded NSF 61 epoxy coating, interior and exterior
    - (9) Romac DJ400 or approved equal
  4. Dresser Style Couplings
    - (1) Shall consist of two steel follower rings, two resilient gaskets, one steel middle ring, EPDM rubber wedge, and a set of steel follower trackhead bolts.
    - (2) Steel to Steel – prepare ends per manufacturer’s recommendations
    - (3) Externally restrained / rodded (stainless steel)
    - (4) Romac 501 or approved equivalent
  5. MegaLug
    - (1) MegaLug by EBAA Iron or approved equal
    - (2) Fusion bonded epoxy
    - (3) Domestic Iron
  6. Restrained Transition Couplings – (steel vault to ductile iron water main)
    - (1) Restrained couplings Typically used to join steel pipe (e.g. from vault) to ductile iron pipe water main.
    - (2) Insulating Coupling with separate insulated restraining rods system including rod sleeves, isolation washer/hardware kit.
    - (3) Style shall be from steel pipe size to ductile iron pipe size.
    - (4) Coupling shall have factory fusion-bonded epoxy coating or approved equal.
    - (5) The restraints or double end rods and nuts shall be manufactured of stainless steel nuts and bolts or have a factory-applied corrosion-resistant coating.
    - (6) Coupling shall incorporate dissimilar metals insulating boot and gasket kit including isolation sleeves for tie-rods.
    - (7) The couplings shall be insulating couplings with insulated restraining rods from vault to pipe.

## C. CORROSION PROTECTION

1. Interior Coatings
  - (1) Ductile iron fittings shall have a cement mortar lining and seal coat in accordance with AWWA C104/A21.4.
  - (2) Fittings
    - (a) Buried fittings may be either factory fusion-bonded epoxy coated per AWWA C550, or cement mortar lined seal coat in accordance with AWWA C104/A21.4. Lining shall be NSF 61 certified.

## D. GASKETS

1. General Materials
  - (1) All gasket materials shall comply with Table 5-1 of AWWA M-41 and per AWWA C110, C111, and C115
  - (2) Rubber-gasket joints shall conform to AWWA C111
  - (3) Gaskets shall have proven performance in the potable water industry for resistance to chlorinated and chloraminated water systems.
  - (4) Generally EPDM material shall be used for all pipes, fittings and valves.
  - (5) Gaskets shall be supplied by the pipe or fitting manufacturer.
  - (6) Comply with applicable joint type and pressure rating of the pipe system.
2. Push-On Joints:
  - (1) EPDM material
  - (2) Nitrile (NBR) shall be used within 200 feet of any buried underground petroleum storage tank
  - (3) "Joint Restraint"
    - (a) Shall be used minimum within 200 feet of any facility such as a tank, pump station or control valve vault (e.g. PRV) or as shown on plans for pipe sizes <16-inches.
    - (b) US Pipe Field-Lok, or American Fast-Grip, or approved equal.
3. Flanged Joints
  - (1) Gaskets shall be full face
  - (2) Pre-punched holes
  - (3) Minimum 1/8" thick
  - (4) EPDM or Viton material
  - (5) Special pressure rated for 350psi such as US Pipe "Flange-Tyte" or American "Toruseal" or approved equal.
4. Flange Isolation Kits
  - (1) Isolating and Sealing Gasket
    - (a) One full faced isolating and sealing gasket, LineBacker Type "E", 1/8" thick, G-10 retainer containing a precision tapered groove to accommodate the controlled compression of a Teflon (or Viton) quad-ring sealing element. Sealing element placement shall accommodate either flat, raised face or RTJ flanges. The quad-ring seal shall be pressure energized. The G-10 retainer shall have a 550 volts/mil dielectric strength and a minimum 50,000 psi compressive strength. The full faced flange isolating gasket shall be 1/8" less in I.D. than the I.D. of the flange in which it is installed.
  - (2) Full Length Bolt Isolating Sleeves
    - (a) One full length G-10 sleeve (extending half way into both steel washers) for each flange bolt. The G-10 shall be a 1/32 inch thick tube with a 400 volts/mil dielectric strength and water absorption of 0.10% or less.
  - (3) Washers
    - (a) Two, 1/8 inch thick, G-10 isolating washers for each bolt. Their compressive strength shall be 50,000 psi, dielectric strength 550 volts/mil and water absorption of 0.10% or less. Two, 1/8 inch thick zinc plated, hot rolled steel washers for each bolt. The I.D. of all washers shall fit over the isolating sleeve and both the steel and isolating washers shall have a same I.D. and O.D.

**SECTION 40 05 61.30  
REPAIR COUPLING AND GASKETS**

1. GENERAL

A. Center Ring, End Ring and Gaskets

1. Standard couplings shall have the ability to be used as a straight coupling as well as a transition coupling.

2. PRODUCT

- A. Couplings shall be ductile iron per ASTM A536 or greater and shall be shop coated for protection during shipment and storage. Ends must have a smooth inside taper for uniform gasket seal. The 4, 6 and 8 inch couplings shall have a center ring length of a minimum of five (5) inches. The 10-12 inch couplings shall have a center ring length of minimum of six (6) inches. The 14-16 inch and larger couplings shall have a center ring length of a minimum of seven (7) inches.
- B. Center rings shall have applicable outside diameter (O.D.) ranges posted on the barrel for easy identification. This may be in the form of stamp or adhered label.
- C. Gaskets shall be sized to fit standard cast and ductile iron pipe and shall be engineered of rubber compound suitable for potable water lines per ASTM D2000. Gaskets must have the size embossed for easy identification.
- D. Transition Rings and Gaskets
  - (a) Transition rings and gaskets must be sized to be used with repair couplings to provide transition in outside diameter (O.D.) ranges from standard pipe to oversized pipe as indicated by outside diameter (O.D.) ranges.
- E. Bolts and Nuts
  - (a) Bolts and Nuts shall be trackhead with a heavy hexagon nut. Bolts and nuts shall be #304 stainless steel with rolled threads and treated to prevent galling.

3. MANUFACTURERS

A. Acceptable Manufacturers (or approved equal):

|                |            |
|----------------|------------|
| Ford Meter Box | Powerseal  |
| JCM            | Romac      |
| Mueller        | SmithBlair |

## SECTION 40 05 65.23 VALVES AND APPURTENANCES

### 1. GENERAL

- A. All valves furnished under this specification shall conform to the latest edition of AWWA C509 “Standard for Resilient Seat Gate Valves for Water Systems” or AWWA C515 Standard, “Reduced- Wall, Resilient-Seated Gate Valves for Water Supply”. Protective interior shall be provided meeting all requirements of the latest edition AWWA C550 Standard, “Protective Interior Coating for Valves and Fire Hydrants” (latest edition). Only ductile iron bodies will be accepted.
- B. Catalog data, net weight and certified drawings as per the latest edition of Section 4.1, 4.2, and 4.3 of AWWA C509 and/or AWWA C515 Standards (latest editions) shall be furnished with submittal.

### 2. PRODUCTS

- A. Resilient-seated gate valves shall conform in all respects to ANSI/AWWA C515-09 with non-rising stems, fully bronze mounted with O-ring seals. Stems shall be made of one piece as per the requirements of AWWA C509 and/or AWWA C515 Standards (Section 4, latest editions). Valves shall be of standard manufacture and of the highest quality both as to materials and workmanship and shall conform to the latest revisions of AWWA Specification C-500. Valves shall have a rated working pressure of 250 psi, and test pressure of 500 psi and shall be opened by turning clockwise only.
- B. All internal components shall be able to withstand without damage or distortion an input torque of 50 ft-lbs. above that listed in the torque test in Section 5 of the AWWA C509 and/or AWWA C515 Standards (latest edition). All test results pertaining to Section 5 of AWWA C509 and/or AWWA C515 Standards (latest edition) shall be furnished upon request.
- C. All bonnet and packing gland nuts and bolts, and operator retainer nuts or pins shall not be less than #304 stainless steel. All bolts and fasteners shall be non-metric. Bonnets for 4” diameter gate valves shall have four (4) bolts. Bonnets for 6” – 12” diameter shall have at least six (6) bolts. Bonnets for 16” diameter and larger shall have bolts per manufacturer recommendation.
- D. All bonnet and packing gland bolts shall be zinc or cadmium electroplated steel; packing gland bolts shall have bronze nuts.
- E. Gate Valves shall be designed for buried service where groundwater may completely submerge the valve and actuator. Gate valves shall be furnished with mechanical joint end connections with stainless steel hardware T-316. The end connections shall be suitable to receive ductile iron pipe. All gate valves 24-inch and larger shall be equipped with mechanical restraint mechanisms to pipe utilizing a positive mechanical restraint such as American’s Coupling Gland Ends, or approved equal, employing stainless steel 316 bolts and nuts. No friction type restraint such as Mega lugs will be acceptable for 24-inch and larger gate valves.
- F. Wheel valves shall have flanged ends rated at 125 lbs. in accordance with AWWA C509 and/or AWWA C515 Standards (latest editions). It shall also conform to the dimensions and drillings of ANSI B16.1, class 125 or ANSI/AWWA C110/A21.10 Standards (latest editions). Wheel valves shall be handwheel operated, left hand open with an arrow symbol (← *LHO*)(left hand open) indicating direction of open. Handwheels shall be ductile iron.
- G. All gate valves supplied shall be MJ x MJ, or Flange x MJ type. The operating nut shall be ductile iron. Gate and tapping valves shall have operating nuts that are right hand open (clockwise) type and labeled for the direction of open with an arrow symbol (→

- RHO)(right hand open). The operating nut locking mechanism shall be visibly centered on the stem.
- H. All valves and appurtenances shall have the name of the manufacturer, year manufactured, valve size, flow-directional arrows, and the working pressure for which they are designed cast in raised letters on some appropriate part of the body.
  - I. The epoxy coating shall be fusion-bonded and shall comply with ANSI/AWWA C550 Standards (latest editions) on all internal and external surfaces of the valve body and bonnet to a minimum thickness of 10 mils.
  - J. The disk shall seat in wedging fashion utilizing two guides, either integral with the body or the wedge. The disk shall be fully encapsulated with EPDM or equivalent rubber.
  - K. Gate valves and tapping valves shall be supplied with a means to lift and handle each valve (i.e. cast-in-place lifting lugs or locking steel collars that attach to the stem directly under the operating nut).
  - L. All valves shall packages shall include MJ Gate accessory packs, bolts and gaskets for tapping and flanged gates as required for installation. The valves shall be protected with end caps, cardboard or plastic, over each outlet to protect the coating on the interior of the valve.
  - M. Contractor shall provide a certificate stating that the valve and all materials used in its construction conform to the requirements of AWWA C509 and/or AWWA C515 Standards (latest editions)..
  - N. Format and location: The gate valves shall be Iron body, Resilient Seat Gate Valve as manufactured by Mueller Co., American Flow Control Series 2500, or an approved equal.
  - O. The valve manufacturer shall supply and integrally mount all valve operators at the factory. The valve and operators shall be shipped as a unit.

**SECTION 40 05 67.36  
WATER PRESSURE REGULATORS FOR PRV**

1. PRODUCT

- A. Regulators must meet requirements of ASSE Standard 1003 – “performance requirements for water pressure reducing valves”.
- B. Regulators must have an integral by-pass check valve.
- C. Regulators must have a built in strainer on regulators 1” and smaller.
- D. Regulators must have bronze bodies with sealed spring cage. Sealed spring cage shall be bronze or corrosion resistant 304 stainless steel or epoxy coated, cast iron with adjusting screw.
- E. Regulators must cover the range of 75-150 PSI and be factory set at 85 - 90 PSI. Bidders must include instructions for adjusting pressure with each regulator.
- F. ¾” Regulators shall be furnished with ¾” male meter thread ends and must meet or exceed a minimum flow capacity of 22 GPM at a 50 PSI drop below set pressure.
- G. 1” Regulators shall be furnished with 1” male meter thread ends and must meet or exceed a minimum flow capacity of 32 GPM at a 50 PSI drop below set pressure.
- H. 1 1/2” Regulators shall be furnished with 1 1/2” NPT threaded female union inlet x NPT female outlet and must meet or exceed a minimum flow capacity of 70 GPM at a 50 PSI drop below set pressure.
- I. 2” Regulators shall be furnished with 2” NPT threaded female union inlet x NPT female outlet and must meet or exceed a minimum flow capacity of 100 GPM at a 50 PSI drop below set pressure.
- J. All nuts and bolts shall be #304 stainless steel.
- K. Elastomers must be EPDM Rubber.

2. MANUFACTURERS

- G. Prequalified models are the following:
  - 1. Watts                   L25AUB-Z3-HR-Z6
  - 2. Wilkins                600 XL HR-SC-DM

## SECTION 40 05 78.11 AIR RELEASE VACUUM VALVE

### 1. GENERAL

- A. Air release and vacuum valves shall be designed to control the flow of large air volumes both into and out of the pipelines to which they are connected. Valves shall be tight against leakage under a working pressure of 250 psi and shop tested at a pressure of 300 psi.

### 2. PRODUCTS

- A. The air release vacuum valve shall be comprised of a small orifice assembly and large orifice assembly housed in a single body. The large orifice assembly shall exhaust air from a pipeline during the initial filling of the pipeline. The large orifice assembly shall not blow shut while exhausting air, even while venting air at sonic velocity. When all air has been exhausted from the pipeline, the large orifice float ball shall be buoyed up to seat tightly against a resilient seat ring. The large orifice float ball shall remain tightly closed while the pipeline is under positive pressure. Should the pipeline pressure fall below atmospheric pressure, the large orifice float ball shall fall away from the seat ring and permit air to enter the pipeline.
- B. The small orifice assembly shall automatically release air accumulations from the pipeline while under positive pressure. When the valve body fills with air, the small orifice float ball falls to open the small orifice and exhaust the air to atmosphere. When the air has been exhausted, the small orifice float shall be buoyed up and tightly close the small orifice. There shall be no baffles, deflectors, or stems.
- C. Each valve shall be furnished with a flanged gate valve for isolation purposes.
- D. Referenced Standards:
  - 1. American Society of Mechanical Engineers (ASME): B16.1, Gray Iron Pipe Flanges and Flanged Fittings: Classes 25, 125, and 250.
  - 2. American Water Works Association (AWWA): C512, Standard for Air-Release, Air Vacuum, and Combination Air Valves for Waterworks Service. C550, Standard for Protective Interior Coatings for Valves and Hydrants.
- E. Air release vacuum valve shall conform to AWWA C512. The exterior of air valves shall be coated in accordance with AWWA C550. The interior of air valves shall be coated in accordance with AWWA C550. Air release vacuum valves shall be factory tested in accordance with AWWA C512. They shall be suitable for operating pressures between 3 and 250 psi for water service. They shall combine operating features of air and vacuum valve, and air release valve. The air and vacuum portion shall automatically exhaust air during filling of system and allow air to re-enter during draining or when vacuum occurs. The air release portion shall automatically exhaust entrained air that accumulates in system. The valve shall be single body or dual body with air/water inlet: NPT and Air Outlet: NPT.

### 3. MANUFACTURERS

- A. Acceptable manufacturers (or Approved Equal):
  - 1. A.R.I. Flow Control Accessories Ltd.; Model D-040-C, D-040-STST.
  - 2. A.R.I. Flow Control Accessories Ltd.; Models S-050-C, S-050-C-V, S-052
- B. Materials:
  - 1. Body and cover: Reinforced nylon body and stainless steel base or stainless steel body and stainless steel base.
  - 2. Base Reinforced nylon or stainless steel.
  - 3. Clamping stem, plug – Reinforced nylon
  - 4. Float – Foamed polypropylene
  - 5. Flange made of reinforced nylon/cast ductile/ ST 37

6. 2-Inch threaded male connection NPT
  7. Discharge outlet – polypropylene
- C. Design requirements:
1. Size: 2 IN.
  2. Working Pressure: 250 psi
  3. Release 10 cfm at 10 psi differential at 150 psi line pressure.
- D. Contractor shall furnish any accessories required to provide a completely operable valve.
- E. Air release vacuum valve shall be complete shop assemble unit including any interconnecting piping, speed control valves, control isolation valves and electrical components.
- F. Air release vacuum valve shall have internal epoxy coating suitable for potable water for all iron body valves in accordance with AWWA C550.
- G. Air release vacuum valve shall be shop hydrostatically tested to piping system test pressure.
- H. Contractor shall provide one (1) set of any special tools or wrenches required for operation or maintenance for each type valve.

**SECTION 40 05 81.13  
FIRE HYDRANTS**

1. PRODUCTS

- A. Fire Hydrants furnished under this bid shall meet or exceed the American Water Works Association (AWWA) latest edition of Standard C502 – “Standard for Dry Barrel Fire Hydrants,” except as otherwise noted in these specifications.
- B. Hydrant inlet shall be 6” DIPS mechanical joint with accessory packs unattached to joint.
- C. Hydrants shall be supplied with black caps and gaskets having 1 ½” pentagon nut and supplied without chains.
- D. All below ground external bolts, studs and nuts (excluding MJ Bolts) shall be 304 stainless steel or approved equal.
- E. Gaskets and other materials shall not contain asbestos.
- F. Manufacturer will provide full detail or chemical composition of all lubrication oil and or grease.
- G. Hydrants shall be furnished in varying depths of bury. Bury depth shall be stenciled on the lower part of the hydrant barrel in a minimum of 3” lettering.

***CASTING AND APPEARANCE***

- A. Hydrants shall be furnished with (2) two – 4” I.D. outlets at 120°. The hydrants operating nut shall be 1 ½” pentagon and 1” minimum in height.
- B. Hydrants furnished shall have all bronze on bronze moving parts. Hydrants shall be coated with a primer and a second coat of the color “traffic orange” or “chrome yellow” as specified by the Project Manager.
- C. Hydrant stem threads shall be Acme Profile. Hydrant nozzle threads shall be copper alloy National Standard Threads.
- D. Distance from the bury line to center of the breakaway flange shall be between 2 & 4 inches. Distance from the bury line to the center of the nozzle shall be between 18 & 24 inches.
- E. Approved bury depths: 3’6”, 4’, 4’6”, 5’, 5’6”, 6’ and 6’6”

***HYDRANTS – OPERATION***

- A. Hydrants shall be designed for a minimum working pressure of 200 psi.
- B. Hydrants shall have a minimum main valve openings of 5 ¼”.
- C. All hydrants shall have breakaway stem and barrel. Breakaway stem coupling shall be attached to stem with a coupling pin that protrudes a minimum of 1/2” to facilitate removal. Stem coupling pin must protrude one (1) side only and be secured with a cotter pin. Stem coupling pin material to be 304 stainless steel or approved equal.
- D. The frangible parts (stem coupling and flange) shall break in a manner that prevents damage to other parts of the hydrant.

- E. All hydrants shall have removable valve stem and seat.
- F. Hydrants shall be self-draining.
- G. Hydrant internal drain holes shall comply with the following requirements:
  - i. Minimum of two (2) drain holes per hydrant in the seat ring
  - ii. Minimum drain hole diameter shall be 0.25"
- H. Hydrant external drain ports shall comply with the following requirements:
  - i. Minimum of two (2) drain ports per hydrant
  - ii. Drain ports shall be tapped with NPT
  - iii. Minimum tap size shall be 0.125" NPT
  - iv. Hydrants shall be shipped with drain ports unplugged.
- I. Hydrant valve seat threads shall be copper alloy to copper alloy.
- J. Hydrants shall not exceed a maximum allowable head loss of 13.0 PSI at 1,500gpm.
- K. Hydrant main valve shall close with pressure.
- L. Hydrant lubrication shall be by oil or grease.

2. MANUFACTURERS

- A. Approved manufacturers for fire hydrants are as follows (or approved equal):

|                       |            |
|-----------------------|------------|
| American Flow Control | 6" B84B    |
| The Mueller Centurion | A 425 5/14 |
| US Pipe Metropolitan  | 250 M94    |

**SECTION 40 05 89**  
**KEYTUBE**

1. PRODUCTS

- A. Keytube shall be new corrugated polyethylene pipe with appropriate inside diameter, non-perforated and flexible.
- B. Corrugated polyethylene pipe shall be double wall.
- C. Corrugated polyethylene pipe inner wall thickness shall be a minimum 0.5 mm.
- D. Corrugated polyethylene pipe shall be made in accordance to ASTM 2648, ASTM 477, ASTM 3212 and AASHTO M 252
- E. Corrugated polyethylene pipe shall be black in color.
- F. Corrugated polyethylene pipe shall be suited for heavy construction.

2. MANUFACTURERS

- A. Corrugated polyethylene shall be Maxflo AE Pipe as manufactured by Timewell Drainage Products, Incorporated or approved equal.

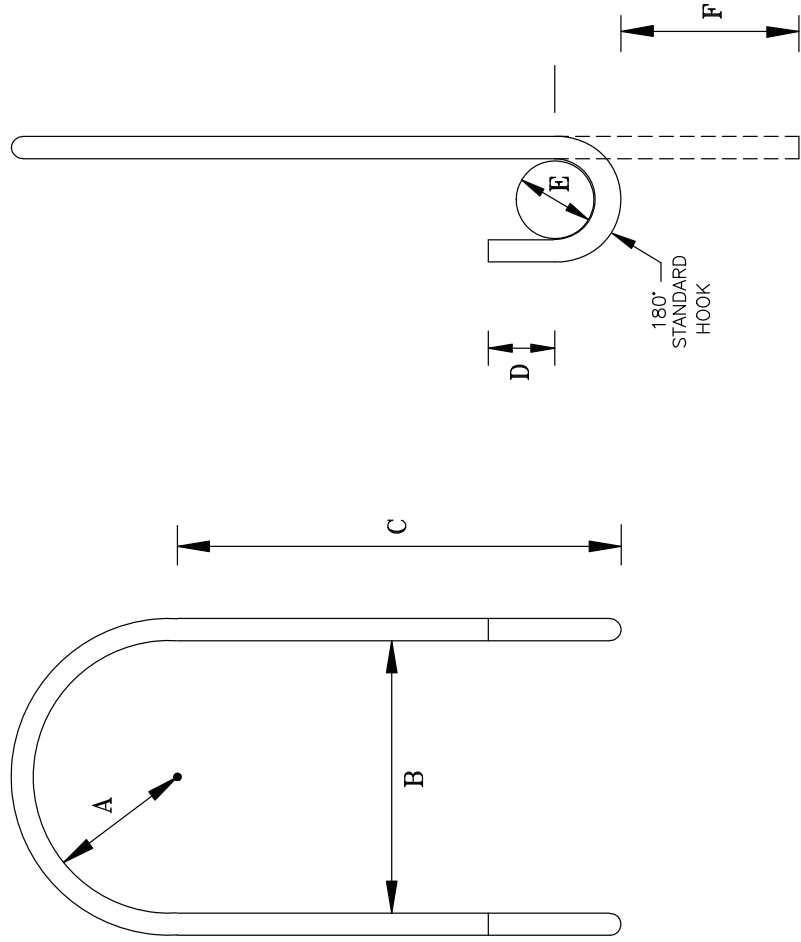

NOTES:

1. REINFORCING STEEL SHALL BE DEFORMED GRADE 60 AND EPOXY COATED.
2. REINFORCING STEEL SHALL BE INSTALLED WITH A MINIMUM DISTANCE OF 3" TO SURROUNDING TRENCH WALLS AND BOTTOM.

REINFORCING SCHEDULE

| GATE VALVE SIZE | BAR SIZE | TOTAL LENGTH (+/-) | A     | B   | C   | D    | E      | F   |
|-----------------|----------|--------------------|-------|-----|-----|------|--------|-----|
| 4" DIA.         | #4       | 62"                | 5"    | 10" | 17" | 2.5" | 3"     | 6"  |
| 6" DIA.         | #4       | 68"                | 6"    | 12" | 18" | 2.5" | 3"     | 6"  |
| 8" DIA.         | #4       | 76"                | 7.5"  | 15" | 20" | 2.5" | 3"     | 6"  |
| 12" DIA.        | #6       | 103"               | 9.5"  | 19" | 28" | 3"   | 4.5"   | 8"  |
| 16" DIA.        | #8       | 155"               | 12"   | 24" | 47" | 4"   | 6"     | 11" |
| 20" DIA.        | #10      | 218"               | 13.5" | 27" | 70" | 5"   | 10.75" | 17" |

**LOUISVILLE WATER COMPANY**  
509 S. 3RD STREET, SUITE 200  
 LOUISVILLE, KY 40202-1000  
 (502) 584-3600  
**REGISTRY C. HEITZMAN, PRESIDENT**  
**JAMES H. BRAMMILL - VICE PRESIDENT/CHIEF ENGINEER**

STANDARD DRAWING  
 REINFORCING STEEL FOR  
 ANCHORING GATE VALVES

|             |           |       |        |
|-------------|-----------|-------|--------|
| DATE        | JUNE 2009 | SCALE | NONE   |
| DRAWING NO. | 5006      | SHEET | 1 OF 1 |

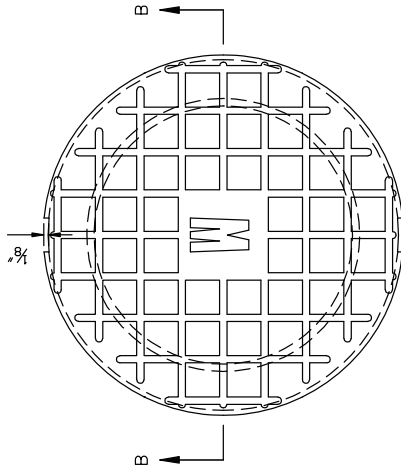

PLAN

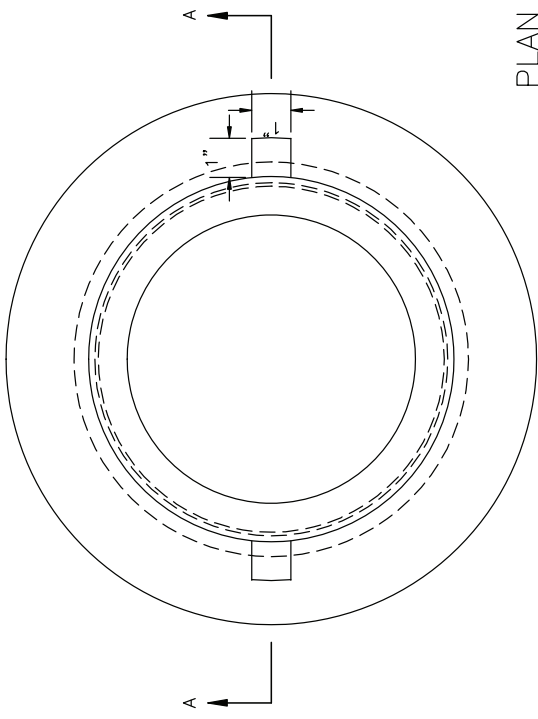

PLAN

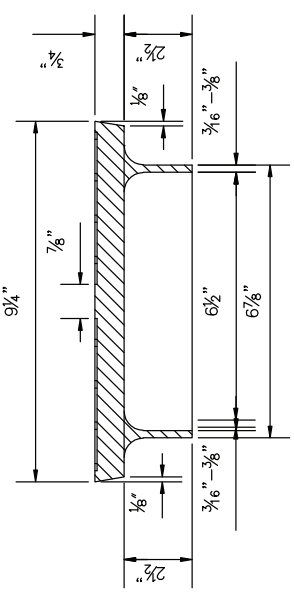

SECTION B-B  
LID

NOTE  
LID HAS WAFFLE DESIGN OF 7/8" SQUARES WITH 1/6" DEEP x 3/16" WIDE VALLEYS BETWEEN SQUARES WITH A BLOCK TYPE LETTER "W" IN CENTER 1 1/2" TALL x 1 1/2" WIDE WITH 1/4" WIDE BARS AROUND WHICH A SQUARE BACKGROUND 2 1/2" x 2 1/2" x 1/6" DEEP HAS BEEN CAST THE WAFFLE DESIGN IS OPTIONAL CASTING DIMENSIONS SHOWN ARE MINIMAL THICKNESSES  
CASTING TOLERANCES ARE + 1/6" FOR VALVE BOX FRAME AND - 1/6" FOR LID  
SHOP DRAWINGS MUST BE SUBMITTED TO THE ENGINEER FOR APPROVAL.

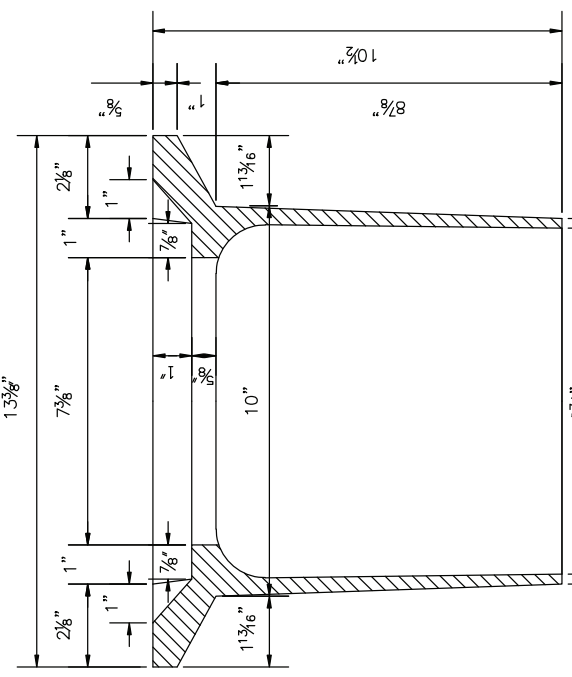

SECTION A-A  
FRAME

|  |            |       |        |
|--|------------|-------|--------|
| <b>LOUISVILLE WATER COMPANY</b><br>500 S. 3RD STREET • LOUISVILLE, KENTUCKY 40202 • (502) 560-3000<br>GREGORY C. HEITZMAN - PRESIDENT<br>JAMES H. BRAMMELL - VICE PRESIDENT/CHIEF ENGINEER |            |       |        |
| STANDARD DRAWING<br>VALVE BOX & LID  |            |       |        |
| DATE   | MARCH 2008 | SCALE | NONE   |
| DRAWING NO.  | 5000       | SHEET | 1 OF 1 |

MEASUREMENT FROM ANGLE METER VALVE  
FLANGE TO ANGLE CHECK VALVE FLANGE  
MUST BE  
13 3/8"

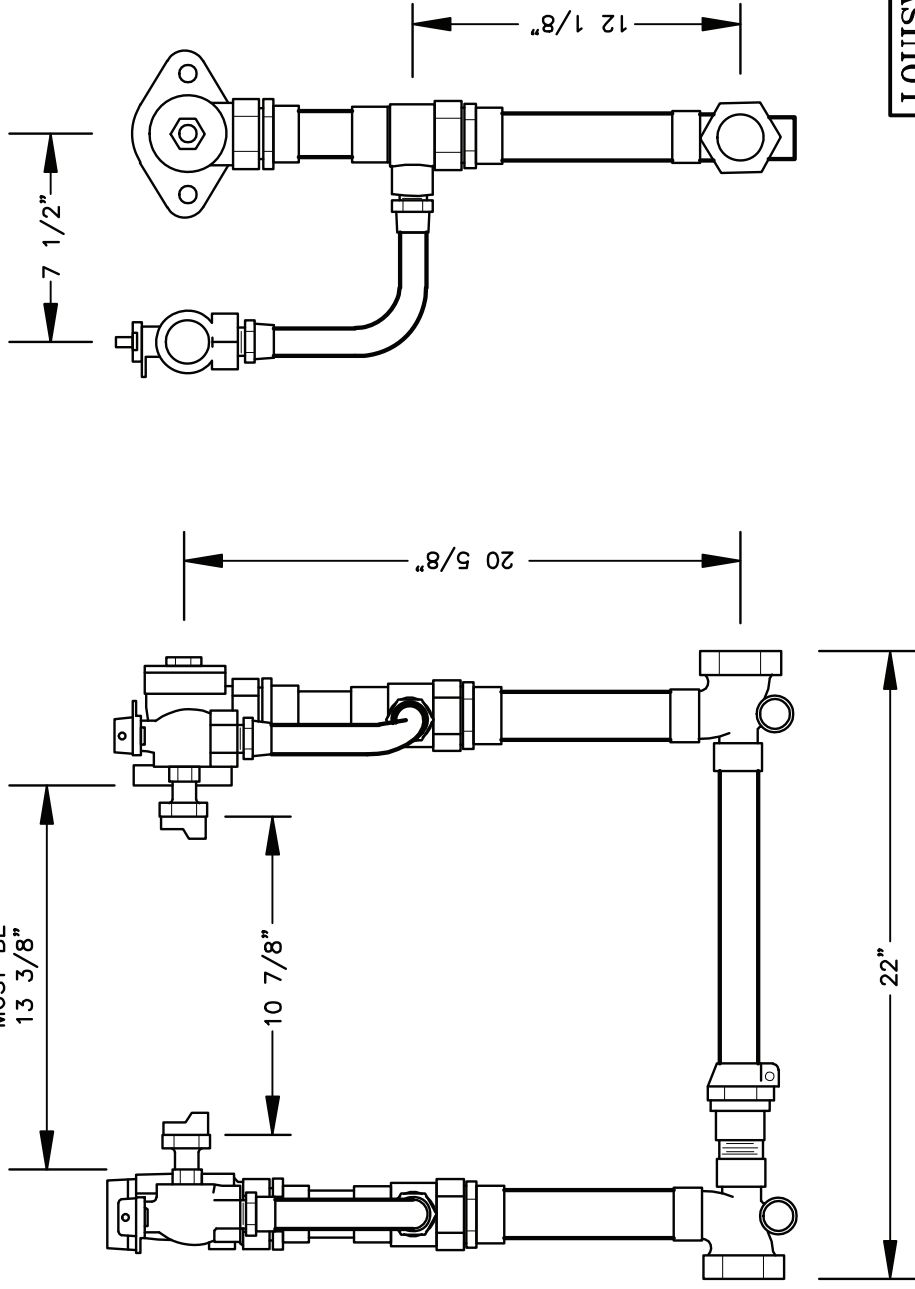

**LOUISVILLE WATER COMPANY**  
550 S. 3RD STREET • LOUISVILLE, KENTUCKY 40202 • (502) 569-3600  
GREGORY C. HEITZMAN - PRESIDENT  
JAMES H. BRAMMELL - VICE PRESIDENT/CHIEF ENGINEER

STANDARD DRAWING

1 1/2" METER SETTER  
WITH 1" BY-PASS

|             |           |       |        |
|-------------|-----------|-------|--------|
| DATE        | JUNE 2008 | SCALE | NONE   |
| DRAWING NO. | 3204      | SHEET | 1 OF 1 |

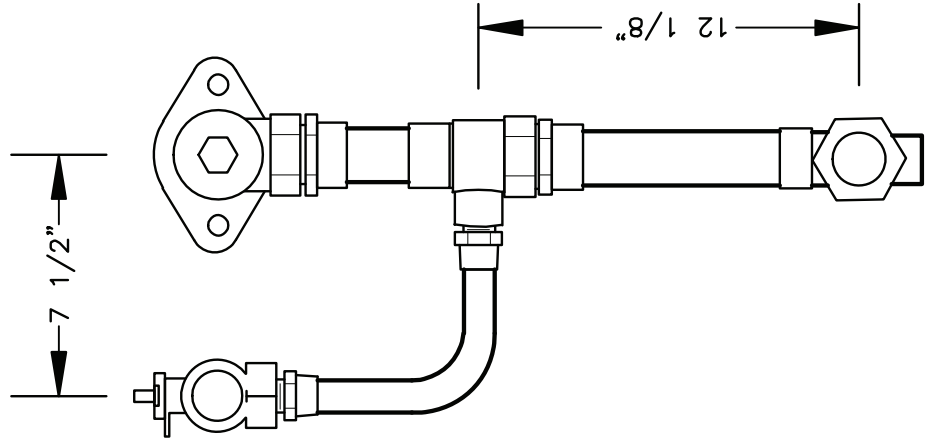

MEASUREMENT FROM ANGLE METER VALVE  
 FLANGE TO ANGLE CHECK VALVE FLANGE  
 MUST BE  
 17 3/8"

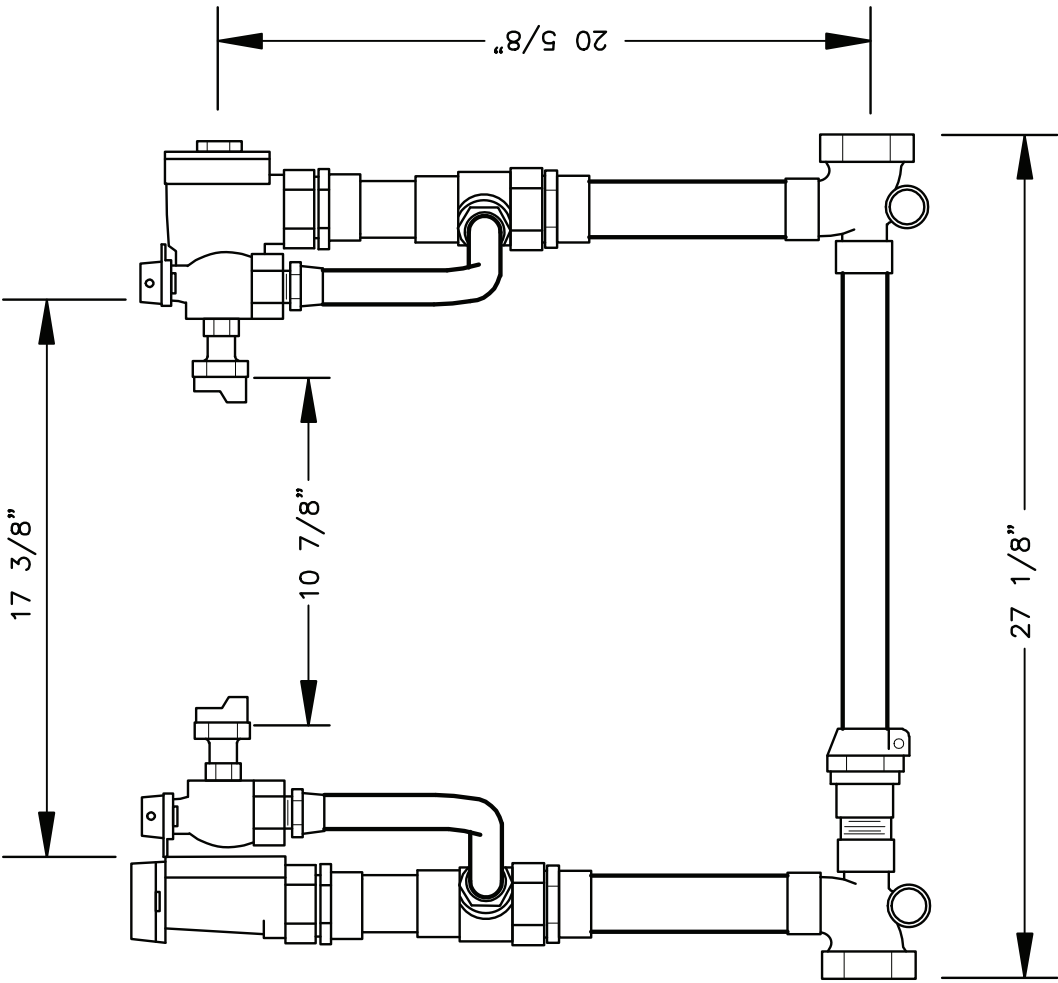

**LOUISVILLE WATER COMPANY**  
 550 S. 3RD STREET • LOUISVILLE, KENTUCKY 40202 • (502) 569-3600  
**GREGORY C. HEITZMAN - PRESIDENT**  
**JAMES H. BRAMMELL - VICE PRESIDENT/CHIEF ENGINEER**

STANDARD DRAWING  
 2" METER SETTER  
 WITH 1" BY-PASS

|             |           |       |        |
|-------------|-----------|-------|--------|
| DATE        | JUNE 2008 | SCALE | NONE   |
| DRAWING NO. | 3205      | SHEET | 1 OF 1 |

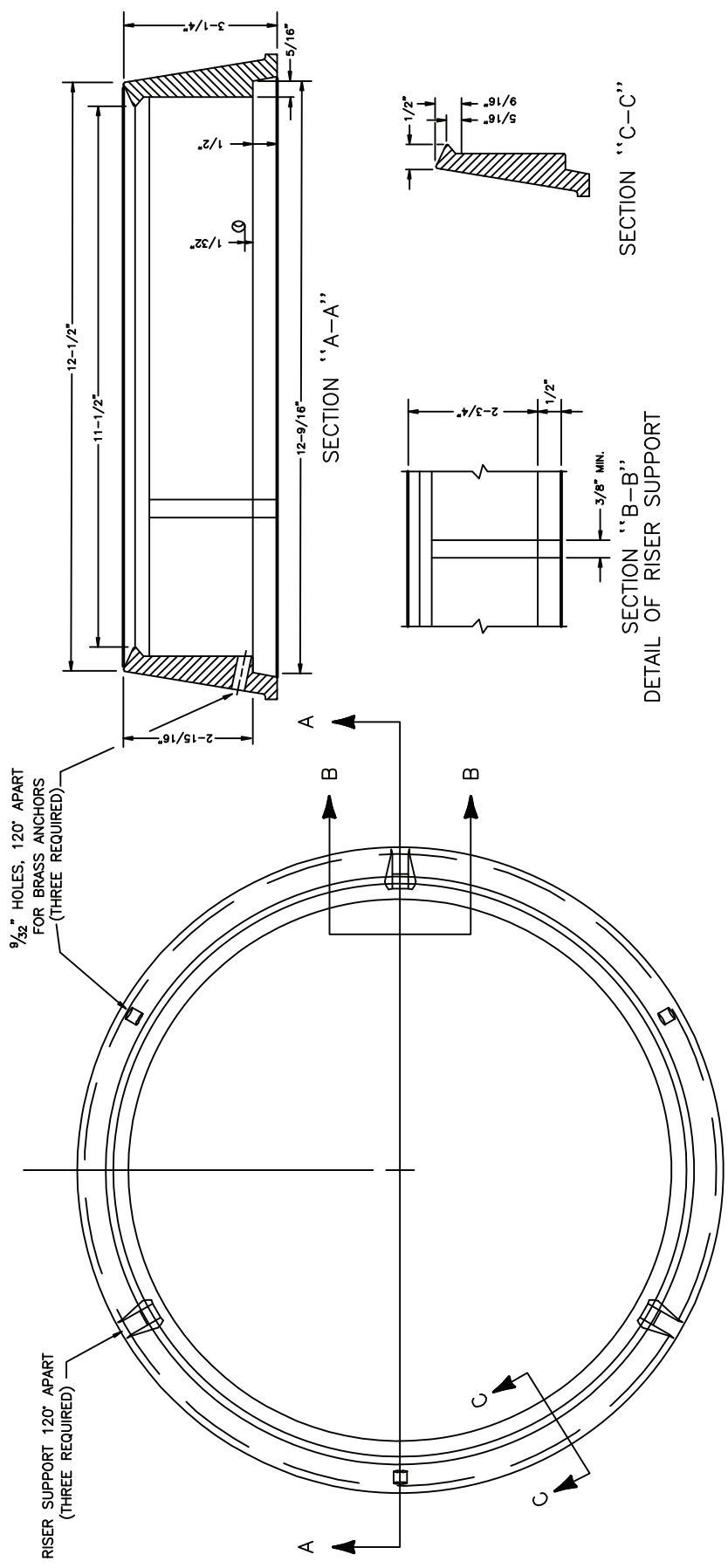

9/32" HOLES, 120° APART  
 FOR BRASS ANCHORS  
 (THREE REQUIRED)

RISER SUPPORT 120° APART  
 (THREE REQUIRED)

SECTION "A-A"

SECTION "C-C"

SECTION "B-B"  
 DETAIL OF RISER SUPPORT

TOP VIEW

1/4" THREADED HOOK WITH NUT  
 (THREE REQUIRED)  
 MUST BE INSTALLED ON RISER  
 FRAME PRIOR TO DELIVERY  
 AT LOUISVILLE WATER CO.

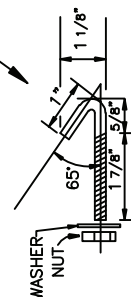

BRASS OR BRONZE  
 HOOK ANCHOR  
 NO SCALE

|   |           |
|---|-----------|
| <b>LOUISVILLE WATER COMPANY</b>   |           |
| 550 S. 3RD STREET • LOUISVILLE, KENTUCKY 40202 • (502) 569-3000                   |           |
| GREGORY C. HEITZMAN - PRESIDENT   |           |
| JAMES H. BRAMWELL - VICE PRESIDENT/CHIEF ENGINEER                                 |           |
| <b>STANDARD DRAWING</b>   |           |
| 3" ELEVATOR RISER RING<br>(J-HOOK STYLE) FOR SMALL<br>METER VAULT FRAMES AND LIDS |           |
| DATE  | JULY 2009 |
| SCALE   | NONE      |
| DRAWING NO.   | 5102      |
| SHEET   | 1 OF 1    |

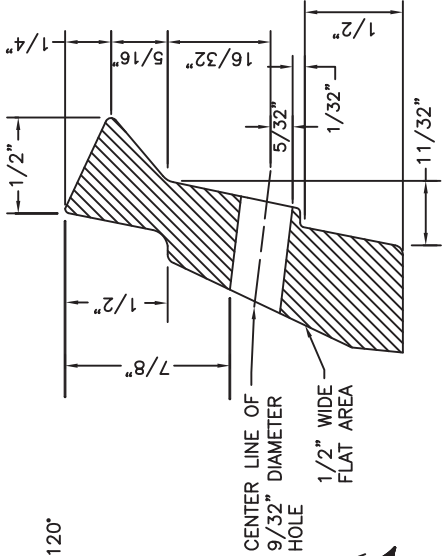
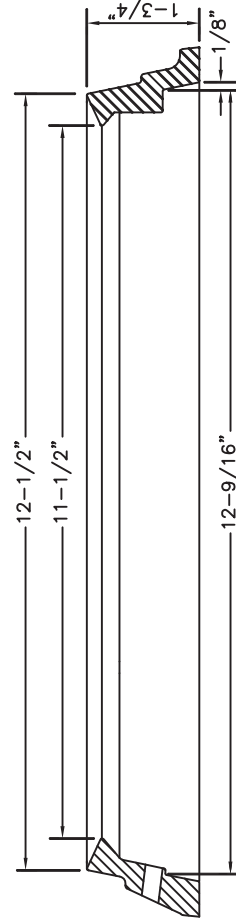
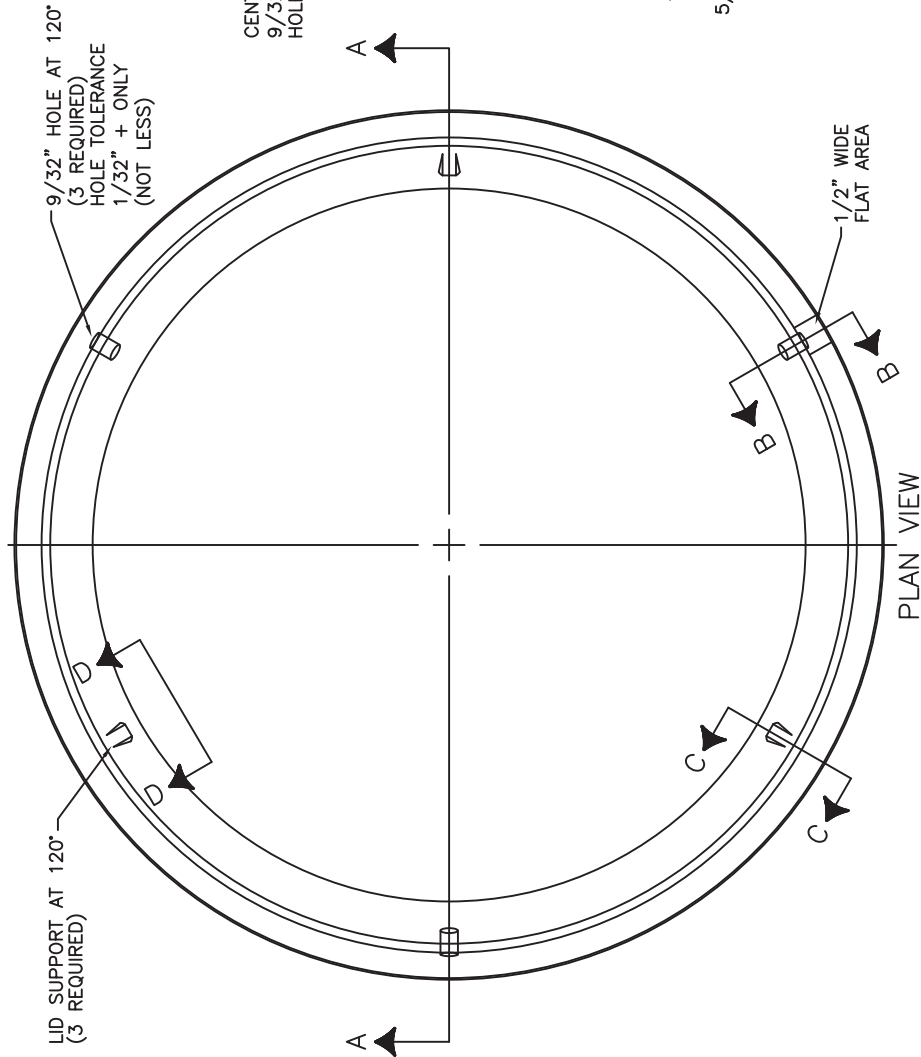

SECTION "B-B"

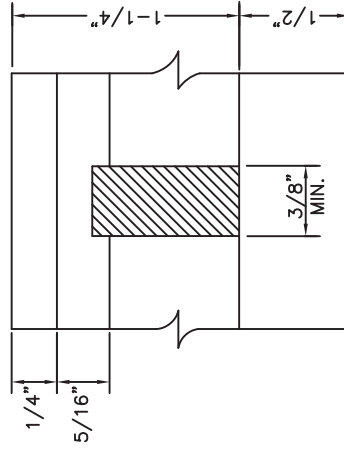

SECTION "D-D"  
DETAIL OF RISER SUPPORT

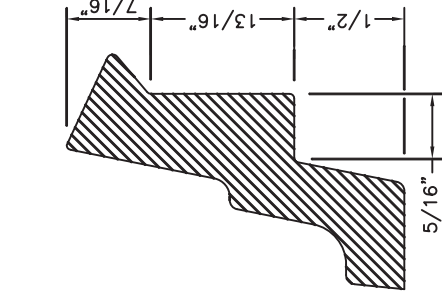

SECTION "C-C"

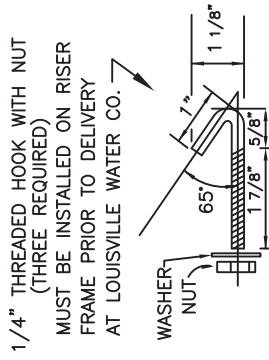

BRASS OR BRONZE  
HOOK ANCHOR  
NO SCALE

**LOUISVILLE WATER COMPANY**  
550 S. 3RD STREET - LOUISVILLE, KENTUCKY 40202 - (502) 566-3600  
GREGORY C. HEITZMAN - PRESIDENT  
JAMES H. BRAMMELL - VICE PRESIDENT/CHIEF ENGINEER

STANDARD DRAWING  
1-1/2" ELEVATOR RISER RING (J-HOOK) FOR SMALL METER VAULT FRAMES AND LIDS

|             |          |       |        |
|-------------|----------|-------|--------|
| DATE        | MAY 2010 | SCALE | NONE   |
| DRAWING NO. | 5103     | SHEET | 1 OF 1 |

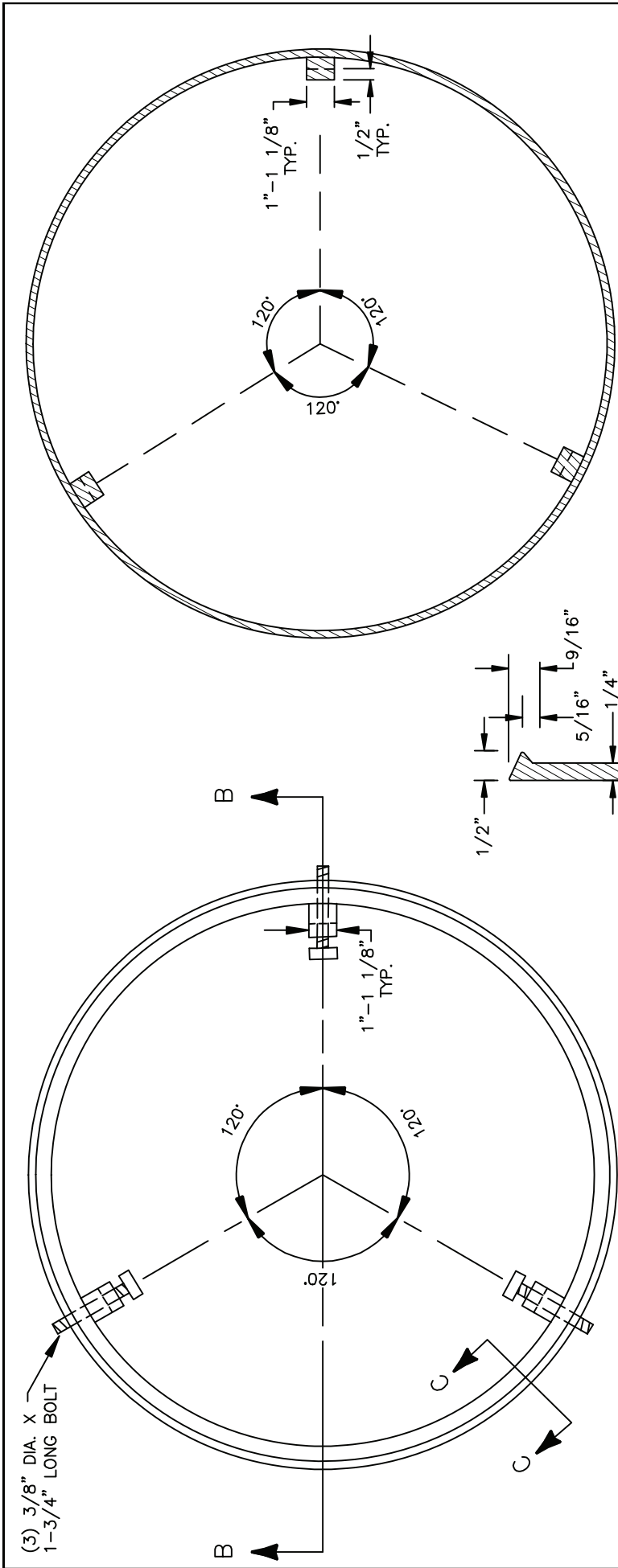

SECTION "A-A"

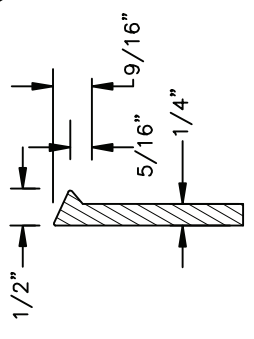

PLAN

SECTION "C-C"

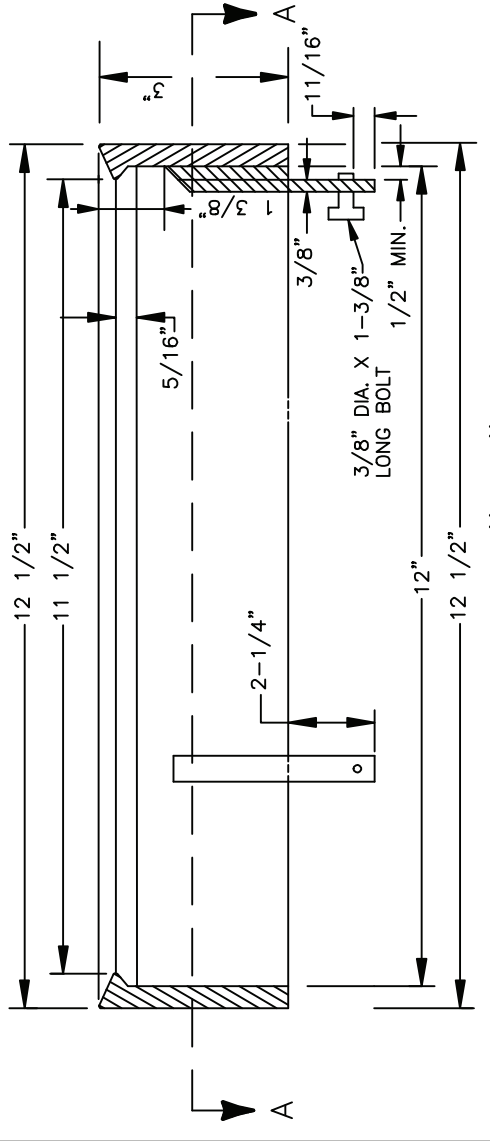

SECTION "B-B"

|  |          |       |        |
|--|----------|-------|--------|
| <b>LOUISVILLE WATER COMPANY</b><br>560 S. 3RD STREET • LOUISVILLE, KENTUCKY 40202 • (502) 566-3600<br>GREGORY C. HEITZMAN - PRESIDENT<br>JAMES H. BRAMMELL - VICE PRESIDENT/CHIEF ENGINEER |          |       |        |
| STANDARD DRAWING<br>3" RISER (HEX HEAD BOLT)<br>FOR SMALL METER VAULT COVERS   |          |       |        |
| DATE   | DEC 2010 | SCALE | NONE   |
| DRAWING NO.  | 5103B    | SHEET | 1 OF 1 |

SHADED AREA FOR  
 MANUFACTURER'S NAME/LOGO,  
 LETTERING TO .7" IN HEIGHT.

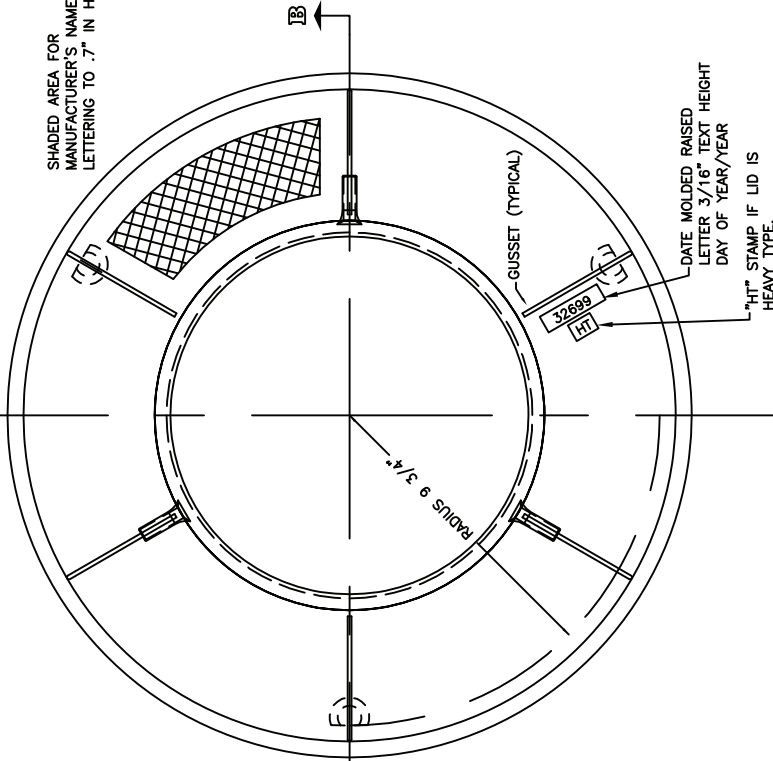

**HEAVY METER VAULT FRAME**

SHADED AREA FOR  
 MANUFACTURER'S NAME/LOGO,  
 LETTERING TO .7" IN HEIGHT.

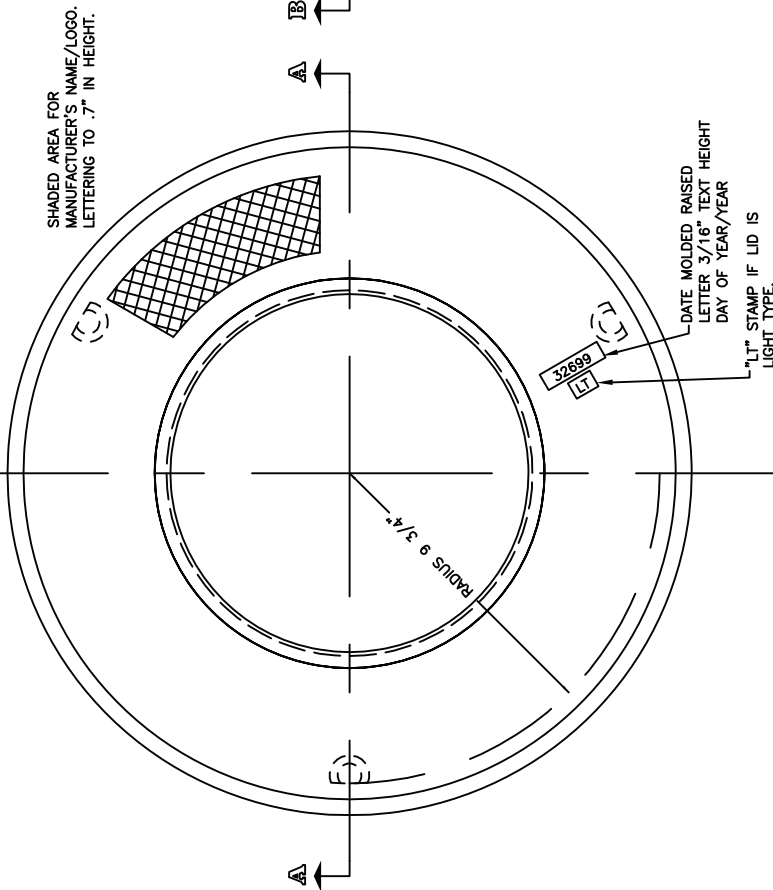

**LIGHT METER VAULT FRAME**

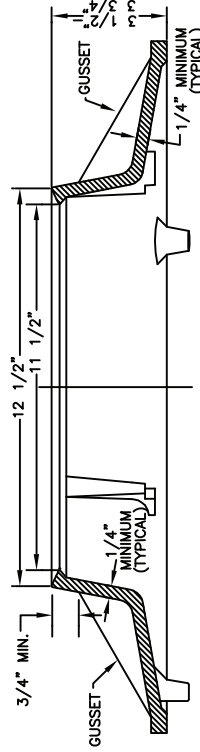

**SECTION B-B  
 HEAVY METER VAULT FRAME**

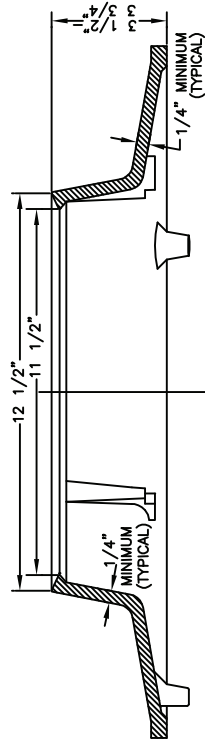

**SECTION A-A  
 LIGHT METER VAULT FRAME**

**LOUISVILLE WATER COMPANY**  
 550 S. 3RD STREET • LOUISVILLE, KENTUCKY 40202 • (502) 568-3600  
 SPENCER W. BRUCE, P.E. - PRESIDENT  
 TIMOTHY KRAUS, P.E. - VICE PRESIDENT / CHIEF ENGINEER

|                                    |                |       |        |
|------------------------------------|----------------|-------|--------|
| <b>STANDARD DRAWING</b>            |                |       |        |
| <b>LIGHT AND HEAVY VAULT FRAME</b> |                |       |        |
| DATE                               | SEPTEMBER 2019 | SCALE | NONE   |
| DRAWING NO.                        | 5104           | SHEET | 1 of 1 |

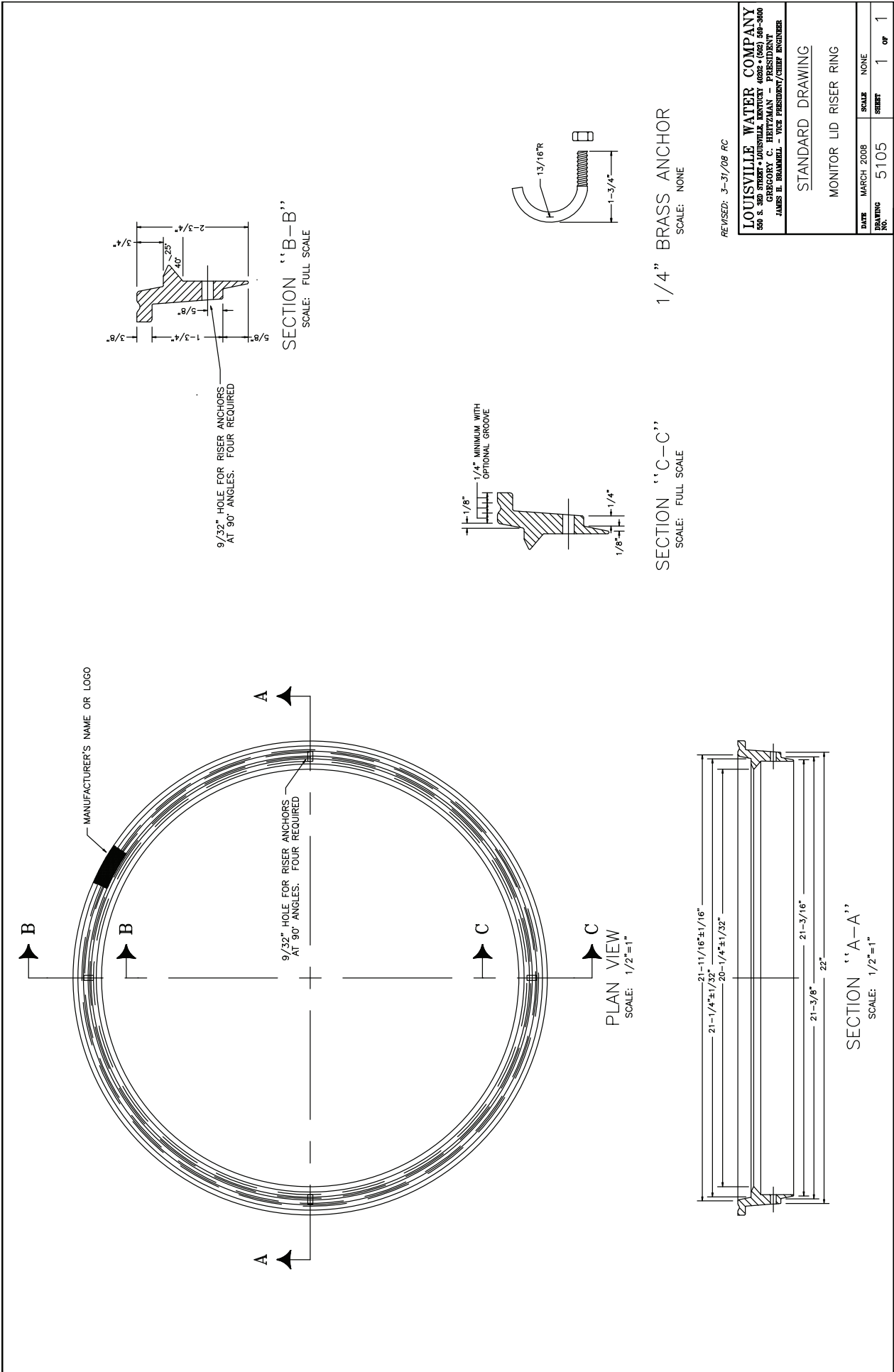

SECTION "B-B"  
SCALE: FULL SCALE

SECTION "C-C"  
SCALE: FULL SCALE

1/4" BRASS ANCHOR  
SCALE: NONE

REVISED: 3-31/08 RC

|   |            |
|---|------------|
| <b>LOUISVILLE WATER COMPANY</b><br>500 S. 3RD STREET • LOUISVILLE, KENTUCKY 40202 • (502) 569-3000<br>GREGORY C. HEITZMAN - PRESIDENT<br>JAMES H. BRAMMEL - VICE PRESIDENT/CHIEF ENGINEER |            |
| STANDARD DRAWING  |            |
| MONITOR LID RISER RING  |            |
| DATE  | MARCH 2008 |
| DRAWING NO.   | 5105       |
| SCALE   | NONE       |
| SHEET   | 1 OF 1     |

SECTION "A-A"  
SCALE: 1/2"=1"

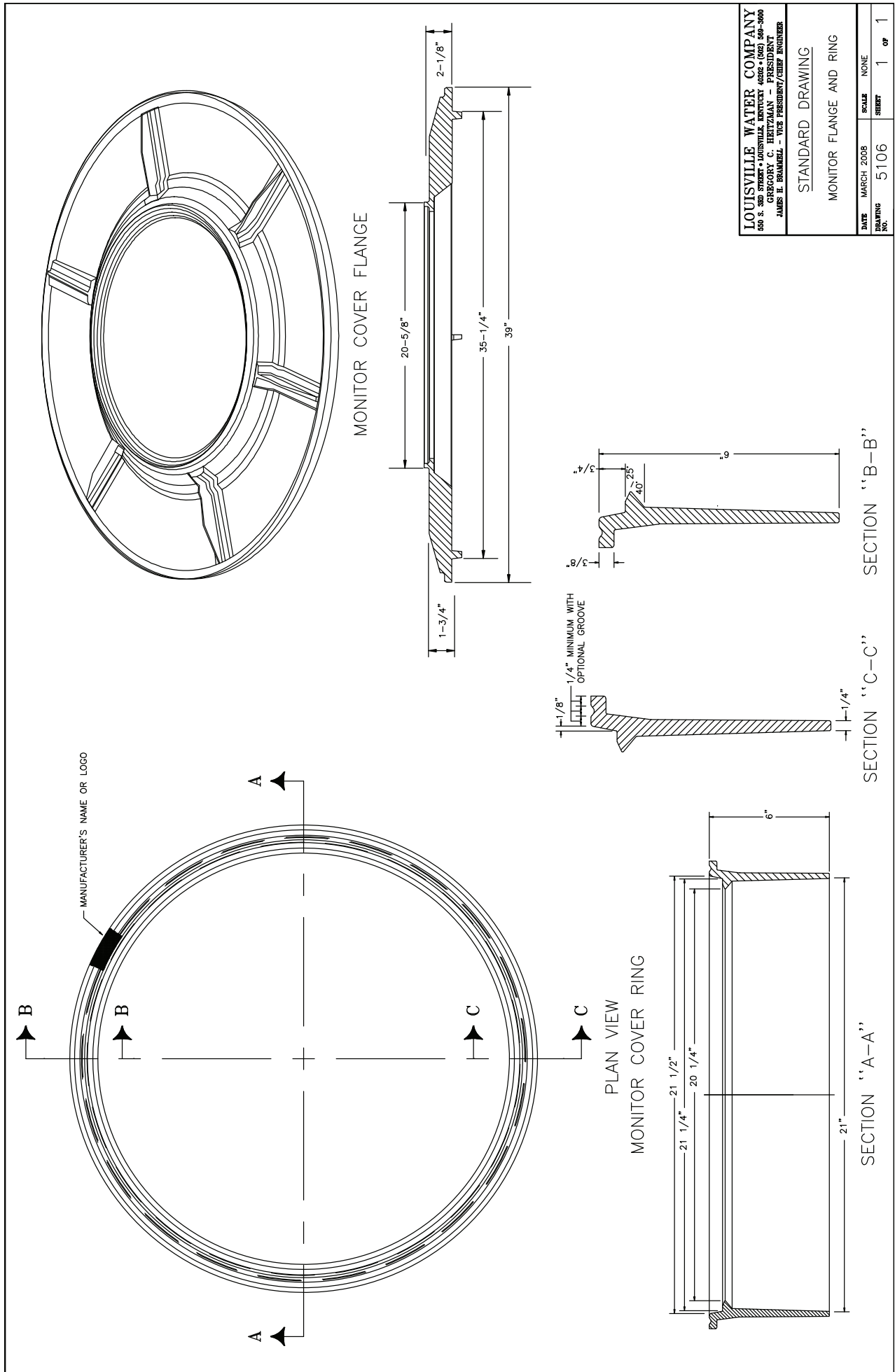

**LOUISVILLE WATER COMPANY**  
550 S. 3RD STREET • LOUISVILLE, KENTUCKY 40202 • (502) 588-3800  
GREGORY C. HETZELMAN - PRESIDENT  
JAMES H. BRAMMELL - VICE PRESIDENT/SENIOR ENGINEER

STANDARD DRAWING

MONITOR FLANGE AND RING

|             |            |       |        |
|-------------|------------|-------|--------|
| DATE        | MARCH 2008 | SCALE | NONE   |
| DRAWING NO. | 5106       | SHEET | 1 OF 1 |

X-NPT TAP DRILL SIZE  
Y-PIPE DEPTH MIN.

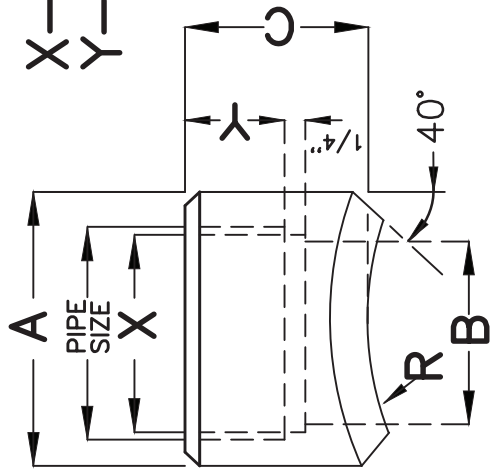

**NOTE:**  
FOR TAKE OFF DIM'S  
ADD "C" DIM, PLUS  
HALF THE HEADER SIZE.

| PIPE SIZE | A     | B     | C     | Y     | R     |
|-----------|-------|-------|-------|-------|-------|
| 1/2       | 1.125 | .687  | 1.000 | .781  | 0.420 |
| 3/4       | 1.375 | .875  | 1.125 | .793  | 0.525 |
| 1         | 1.625 | 1.125 | 1.375 | .984  | 0.657 |
| 1 1/4     | 2.062 | 1.437 | 1.500 | 1.008 | 0.830 |
| 1 1/2     | 2.250 | 1.687 | 1.500 | 1.025 | 0.950 |
| 2         | 2.875 | 2.218 | 1.750 | 1.058 | 1.187 |
| 2 1/2     | 3.375 | 2.500 | 2.000 | 1.571 | 1.437 |
| 3         | 4.000 | 3.125 | 2.500 | 1.633 | 1.750 |

ALL DIMENSIONS ARE INCHES.  
(ENGLISH UNITS)

**LOUISVILLE WATER COMPANY**  
550 S. 3RD STREET • LOUISVILLE, KENTUCKY 40202 • (502) 560-3000  
GREGORY C. HEITZMAN - PRESIDENT  
JAMES H. BRAMMELL - VICE PRESIDENT/CHIEF ENGINEER

STANDARD DRAWING  
WELDOLET  
FITTING

|             |               |       |        |
|-------------|---------------|-------|--------|
| DATE        | FEBRUARY 2012 | SCALE | NONE   |
| DRAWING NO. | 9004          | SHEET | 1 OF 1 |

X-NPT TAP DRILL SIZE  
Y-PIPE DEPTH MIN.

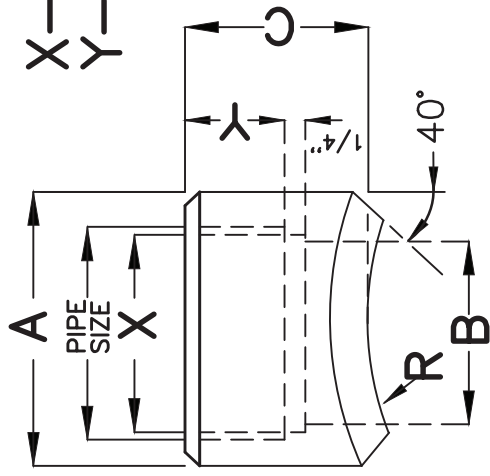

**NOTE:**  
FOR TAKE OFF DIM'S  
ADD "C" DIM, PLUS  
HALF THE HEADER SIZE.

| PIPE SIZE | A     | B     | C     | Y     | R     |
|-----------|-------|-------|-------|-------|-------|
| 1/2       | 1.125 | .687  | 1.000 | .781  | 0.420 |
| 3/4       | 1.375 | .875  | 1.125 | .793  | 0.525 |
| 1         | 1.625 | 1.125 | 1.375 | .984  | 0.657 |
| 1 1/4     | 2.062 | 1.437 | 1.500 | 1.008 | 0.830 |
| 1 1/2     | 2.250 | 1.687 | 1.500 | 1.025 | 0.950 |
| 2         | 2.875 | 2.218 | 1.750 | 1.058 | 1.187 |
| 2 1/2     | 3.375 | 2.500 | 2.000 | 1.571 | 1.437 |
| 3         | 4.000 | 3.125 | 2.500 | 1.633 | 1.750 |

ALL DIMENSIONS ARE INCHES.  
(ENGLISH UNITS)

**LOUISVILLE WATER COMPANY**  
550 S. 3RD STREET • LOUISVILLE, KENTUCKY 40202 • (502) 560-3000  
GREGORY C. HEITZMAN - PRESIDENT  
JAMES H. BRAMMELL - VICE PRESIDENT/CHIEF ENGINEER

STANDARD DRAWING  
WELDOLET  
FITTING

|             |               |       |        |
|-------------|---------------|-------|--------|
| DATE        | FEBRUARY 2012 | SCALE | NONE   |
| DRAWING NO. | 9004          | SHEET | 1 OF 1 |

KyTC BMP Plan for Project PCN 5–9016.00



**Kentucky Transportation Cabinet**

**Highway District 5**

**And**

\_\_\_\_\_ (2), Construction

**Kentucky Pollutant Discharge Elimination System  
Permit KYR10**

**Best Management Practices (BMP) plan**

**Groundwater protection plan**

**For Highway Construction Activities**

**For**

**Fegenbush Lane at Fenwick Drive Left Turn Lane**

**Project: PCN 5–9016.00**

## KyTC BMP Plan for Project PCN 5–9016.00

### Project information

Note – (1) = Design (2) = Construction (3) = Contractor

1. Owner – Kentucky Transportation Cabinet, District 5
2. Resident Engineer: (2)
3. Contractor name: (2)  
Address: (2)  
  
Phone number: (2)  
Contact: (2)  
Contractors agent responsible for compliance with the KPDES permit requirements (3):
4. Project Control Number (2)
5. Route (Address): Fegenbush Lane, Louisville, KY 40228
6. Latitude/Longitude (project mid-point): 38/9/18, 85/38/11
7. County (project mid-point): Jefferson
8. Project start date (date work will begin): (2)
9. Projected completion date: (2)

## KyTC BMP Plan for Project PCN 5–9016.00

### A. Site description:

1. Nature of Construction Activity (from letting project description): Grade, Drain & Asphalt Resurfacing
2. Order of major soil disturbing activities (2) and (3)
3. Projected volume of material to be moved: 258 CY
4. Estimate of total project area (acres): 1.35 Ac
5. Estimate of area to be disturbed (acres): 0.92 Ac
6. Post construction runoff coefficient will be included in the project drainage folder. Persons needing information pertaining to the runoff coefficient will contact the resident engineer to request this information.
7. Data describing existing soil condition: No Data Reported & (2)
8. Data describing existing discharge water quality (if any): None & (2)
9. Receiving water name: Tributary to Fern Creek
10. TMDLs and Pollutants of Concern in Receiving Waters: None (DEA)
11. Site map – Project layout sheet plus the erosion control sheets in the project plans that depict Disturbed Drainage Areas (DDAs) and related information. These sheets depict the existing project conditions with areas delineated by DDA (drainage area bounded by watershed breaks and right of way limits), the storm water discharge locations (either as a point discharge or as overland flow) and the areas that drain to each discharge point. These plans define the limits of areas to be disturbed and the location of control measures. Controls will be either site specific as designated by the designer or will be annotated by the contractor and resident engineer before disturbance commences. The project layout sheet shows the surface waters and wetlands.
12. Potential sources of pollutants:  
  
The primary source of pollutants is solids that are mobilized during storm events. Other sources of pollutants include oil/fuel/grease from servicing and operating construction equipment, concrete washout water, sanitary wastes and trash/debris. (3)

## KyTC BMP Plan for Project PCN 5–9016.00

### **B. Sediment and Erosion Control Measures:**

1. Plans for highway construction projects will include erosion control sheets that depict Disturbed Drainage Areas (DDAs) and related information. These plan sheets will show the existing project conditions with areas delineated by DDA within the right of way limits, the discharge points and the areas that drain to each discharge point. Project managers and designers will analyze the DDAs and identify Best Management Practices (BMPs) that are site specific. The balance of the BMPs for the project will be listed in the bid documents for selection and use by the contractor on the project with approval by the resident engineer.

Projects that do not have DDAs annotated on the erosion control sheets will employ the same concepts for development and managing BMP plans.

2. Following award of the contract, the contractor and resident engineer will annotate the erosion control sheets showing location and type of BMPs for each of the DDAs that will be disturbed at the outset of the project. This annotation will be accompanied by an order of work that reflects the order or sequence of major soil moving activities. The remaining DDAs are to be designated as “Do Not Disturb” until the contractor and resident engineer prepare the plan for BMPs to be employed. The initial BMP’s shall be for the first phase (generally Clearing and Grubbing) and shall be modified as needed as the project changes phases. The BMP Plan will be modified to reflect disturbance in additional DDA’s as the work progresses. All DDA’s will have adequate BMP’s in place before being disturbed.
3. As DDAs are prepared for construction, the following will be addressed for the project as a whole or for each DDA as appropriate:
  - Construction Access – This is the first land-disturbing activity. As soon as construction begins, bare areas will be stabilized with gravel and temporary mulch and/or vegetation.
  - At the beginning of the project, all DDAs for the project will be inspected for areas that are a source of storm water pollutants. Areas that are a source of pollutants will receive appropriate cover or BMPs to arrest the introduction of pollutants into storm water. Areas that have not been opened by the contractor will be inspected periodically (once per month) to determine if there is a need to employ BMPs to keep pollutants from entering storm water.

## KyTC BMP Plan for Project PCN 5–9016.00

- Clearing and Grubbing – The following BMP's will be considered and used where appropriate.
  - Leaving areas undisturbed when possible.
  - Silt basins to provide silt volume for large areas.
  - Silt Traps Type A for small areas.
  - Silt Traps Type C in front of existing and drop inlets which are to be saved
  - Diversion ditches to catch sheet runoff and carry it to basins or traps or to divert it around areas to be disturbed.
  - Brush and/or other barriers to slow and/or divert runoff.
  - Silt fences to catch sheet runoff on short slopes. For longer slopes, multiple rows of silt fence may be considered.
  - Temporary Mulch for areas which are not feasible for the fore mentioned types of protections.
  - Non-standard or innovative methods.
- Cut & Fill and placement of drainage structures - The BMP Plan will be modified to show additional BMP's such as:
  - Silt Traps Type B in ditches and/or drainways as they are completed
  - Silt Traps Type C in front of pipes after they are placed
  - Channel Lining
  - Erosion Control Blanket
  - Temporary mulch and/or seeding for areas where construction activities will be ceased for 21 days or more.
  - Non-standard or innovative methods
- Profile and X-Section in place – The BMP Plan will be modified to show elimination of BMP's which had to be removed and the addition of new BMP's as the roadway was shaped. Probably changes include:
  - Silt Trap Type A, Brush and/or other barriers, Temporary Mulch, and any other BMP which had to be removed for final grading to take place.
  - Additional Silt Traps Type B and Type C to be placed as final drainage patterns are put in place.
  - Additional Channel Lining and/or Erosion Control Blanket.
  - Temporary Mulch for areas where Permanent Seeding and Protection cannot be done within 21 days.
  - Special BMP's such as Karst Policy
- Finish Work (Paving, Seeding, Protect, etc.) – A final BMP Plan will result from modifications during this phase of construction. Probably changes include:
  - Removal of Silt Traps Type B from ditches and drainways if they are protected with other BMP's which are sufficient to control erosion, i.e. Erosion Control Blanket or Permanent Seeding and Protection on moderate grades.

## KyTC BMP Plan for Project PCN 5–9016.00

- Permanent Seeding and Protection
  - Placing Sod
  - Planting trees and/or shrubs where they are included in the project
- BMP's including Storm Water Management Devices such as velocity dissipation devices and Karst policy BMP's to be installed during construction to control the pollutants in storm water discharges that will occur after construction has been completed are : *This project does not include storm water BMPs or flow controls for post-construction use.*

### C. Other Control Measures

1. No solid materials, including building materials, shall be discharged to waters of the commonwealth, except as authorized by a Section 404 permit.
2. Waste Materials

All waste materials that may leach pollutants (paint and paint containers, caulk tubes, oil/grease containers, liquids of any kind, soluble materials, etc.) will be collected and stored in appropriate covered waste containers. Waste containers shall be removed from the project site on a sufficiently frequent basis as to not allow wastes to become a source of pollution. All personnel will be instructed regarding the correct procedure for waste disposal. Wastes will be disposed in accordance with appropriate regulations. Notices stating these practices will be posted in the office.

3. Hazardous Waste

All hazardous waste materials will be managed and disposed of in the manner specified by local or state regulation. The contractor shall notify the Resident Engineer if there any hazardous wastes being generated at the project site and how these wastes are being managed. Site personnel will be instructed with regard to proper storage and handling of hazardous wastes when required. The Transportation Cabinet will file for generator, registration when appropriate, with the Division of Waste Management and advise the contractor regarding waste management requirements.

4. Spill Prevention

The following material management practices will be used to reduce the risk of spills or other exposure of materials and substances to the weather and/or runoff.

- **Good Housekeeping:**

## KyTC BMP Plan for Project PCN 5-9016.00

The following good housekeeping practices will be followed onsite during the construction project.

- An effort will be made to store only enough product required to do the job
- All materials stored onsite will be stored in a neat, orderly manner in their appropriate containers and, if possible, under a roof or other enclosure
- Products will be kept in their original containers with the original manufacturer's label
- Substances will not be mixed with one another unless recommended by the manufacturer
- Whenever possible, all of the product will be used up before disposing of the container
- Manufacturers' recommendations for proper use and disposal will be followed
- The site contractor will inspect daily to ensure proper use and disposal of materials onsite

### ➤ **Hazardous Products:**

These practices will be used to reduce the risks associated with any and all hazardous materials.

- Products will be kept in original containers unless they are not resealable
- Original labels and material safety data sheets (MSDS) will be reviewed and retained
- Contractor will follow procedures recommended by the manufacturer when handling hazardous materials
- If surplus product must be disposed of, manufacturers' or state/local recommended methods for proper disposal will be followed

### **The following product-specific practices will be followed onsite:**

#### ➤ **Petroleum Products:**

Vehicles and equipment that are fueled and maintained on site will be monitored for leaks, and receive regular preventative maintenance to reduce the chance of leakage. Petroleum products onsite will be stored in tightly sealed containers, which are clearly labeled and will be protected from exposure to weather.

The contractor shall prepare an Oil Pollution Spill Prevention Control and Countermeasure plan when the project that involves the storage of petroleum products in 55 gallon or larger containers with a total combined storage capacity of 1,320 gallons. This is a requirement of 40 CFR 112.

## KyTC BMP Plan for Project PCN 5–9016.00

This project (will / will not) (3) have over 1,320 gallons of petroleum products with a total capacity, sum of all containers 55 gallon capacity and larger.

### ➤ **Fertilizers:**

Fertilizers will be applied at rates prescribed by the contract, standard specifications or as directed by the resident engineer. Once applied, fertilizer will be covered with mulch or blankets or worked into the soil to limit exposure to storm water. Storage will be in a covered shed. The contents of any partially used bags of fertilizer will be transferred to a sealable plastic bin to avoid spills.

### ➤ **Paints:**

All containers will be tightly sealed and stored indoors or under roof when not being used. Excess paint or paint wash water will not be discharged to the drainage or storm sewer system but will be properly disposed of according to manufacturers' instructions or state and local regulations.

### ➤ **Concrete Truck Washout:**

Concrete truck mixers and chutes will not be washed on pavement, near storm drain inlets, or within 75 feet of any ditch, stream, wetland, lake, or sinkhole. Where possible, excess concrete and wash water will be discharged to areas prepared for pouring new concrete, flat areas to be paved that are away from ditches or drainage system features, or other locations that will not drain off site. Where this approach is not possible, a shallow earthen wash basin will be excavated away from ditches to receive the wash water

### ➤ **Spill Control Practices**

In addition to the good housekeeping and material management practices discussed in the previous sections of this plan, the following practices will be followed for spill prevention and cleanup:

- Manufacturers' recommended methods for spill cleanup will be clearly posted. All personnel will be made aware of procedures and the location of the information and cleanup supplies.
- Materials and equipment necessary for spill cleanup will be kept in the material storage area. Equipment and materials will include as appropriate, brooms, dust pans, mops, rags, gloves, oil absorbents, sand, sawdust, and plastic and metal trash containers.
- All spills will be cleaned up immediately after discovery.
- The spill area will be kept well ventilated and personnel will wear appropriate protective clothing to prevent injury from contact with a hazardous substance.

## KyTC BMP Plan for Project PCN 5–9016.00

- Spills of toxic or hazardous material will be reported to the appropriate state/local agency as required by KRS 224 and applicable federal law.
- The spill prevention plan will be adjusted as needed to prevent spills from reoccurring and improve spill response and cleanup.
- Spills of products will be cleaned up promptly. Wastes from spill clean up will be disposed in accordance with appropriate regulations.

### **D. Other State and Local Plans**

This BMP plan shall include any requirements specified in sediment and erosion control plans, storm water management plans or permits that have been approved by other state or local officials. Upon submittal of the NOI, other requirements for surface water protection are incorporated by reference into and are enforceable under this permit (even if they are not specifically included in this BMP plan). This provision does not apply to master or comprehensive plans, non-enforceable guidelines or technical guidance documents that are not identified in a specific plan or permit issued for the construction site by state or local officials. *There are other local (MS4) requirements that are being added to this project.*

### **E. Maintenance**

1. The BMP plan shall include a clear description of the maintenance procedures necessary to keep the control measures in good and effective operating condition.
- Maintenance of BMPs during construction shall be a result of weekly and post rain event inspections with action being taken by the contractor to correct deficiencies.
  - Post Construction maintenance will be a function of normal highway maintenance operations. Following final project acceptance by the cabinet, district highway crews will be responsible for identification and correction of deficiencies regarding ground cover and cleaning of storm water BMPs. The project manager shall identify any BMPs that will be for the purpose of post construction storm water management with specific guidance for any non-routine maintenance. *There are no such BMP's.*

### **F. Inspections**

Inspection and maintenance practices that will be used to maintain erosion and sediment controls:

## KyTC BMP Plan for Project PCN 5–9016.00

- All erosion prevention and sediment control measures will be inspected at least once each week and following any rain of one-half inch or more.
- Inspections will be conducted by individuals that have received KyTC Grade Level II training or other qualification as prescribed by the cabinet that includes instruction concerning sediment and erosion control.
- Inspection reports will be written, signed, dated, and kept on file.
- Areas at final grade will be seeded and mulched within 14 days.
- Areas that are not at final grade where construction has ceased for a period of 21 days or longer and soil stock piles shall receive temporary mulch no later than 14 days from the last construction activity in that area.
- All measures will be maintained in good working order; if a repair is necessary, it will be initiated within 24 hours of being reported.
- Built-up sediment will be removed from behind the silt fence before it has reached halfway up the height of the fence.
- Silt fences will be inspected for bypassing, overtopping, undercutting, depth of sediment, tears, and to ensure attachment to secure posts.
- Sediment basins will be inspected for depth of sediment, and built-up sediment will be removed when it reaches 70 percent of the design capacity and at the end of the job.
- Diversion dikes and berms will be inspected and any breaches promptly repaired. Areas that are eroding or scouring will be repaired and re-seeded / mulched as needed.
- Temporary and permanent seeding and mulching will be inspected for bare spots, washouts, and healthy growth. Bare or eroded areas will be repaired as needed.
- All material storage and equipment servicing areas that involve the management of bulk liquids, fuels, and bulk solids will be inspected weekly for conditions that represent a release or possible release of pollutants to the environment.

### **G. Non – Storm Water discharges**

It is expected that non-storm water discharges may occur from the site during the construction period. Examples of non-storm water discharges include:

- Water from water line flushings.
- Water from cleaning concrete trucks and equipment.

## KyTC BMP Plan for Project PCN 5–9016.00

- Pavement wash waters (where no spills or leaks of toxic or hazardous materials have occurred).
- Uncontaminated groundwater and rain water (from dewatering during excavation).

All non-storm water discharges will be directed to the sediment basin or to a filter fence enclosure in a flat vegetated infiltration area or be filtered via another approved commercial product.

### **H. Groundwater Protection Plan (3)**

This plan serves as the groundwater protection plan as required by 401 KAR 5:037.

- Contractors statement: (3)

The following activities, as enumerated by 401 KAR 5:037 Section 2 that require the preparation and implementation of a groundwater protection plan, will or may be may be conducted as part of this construction project:

\_\_\_\_\_ 2. (e) land treatment or land disposal of a pollutant;

\_\_\_\_\_ 2. (f) Storing, ..., or related handling of hazardous waste, solid waste or special waste, ..., in tanks, drums, or other containers, or in piles, (This does not include wastes managed in a container placed for collection and removal of municipal solid waste for disposal off site);

\_\_\_\_\_ 2. (g) .... Handling of materials in bulk quantities (equal or greater than 55 gallons or 100 pounds net dry weight transported held in an individual container) that, if released to the environment, would be a pollutant;

\_\_\_\_\_ 2. (j) Storing or related handling of road oils, dust suppressants, ....., at a central location;

\_\_\_\_\_ 2. (k) Application or related handling of road oils, dust suppressants or deicing materials, (does not include use of chloride-based deicing materials applied to roads or parking lots);

\_\_\_\_\_ 2. (m) Installation, construction, operation, or abandonment of wells, bore holes, or core holes, (this does not include bore holes for the purpose of explosive demolition);

Or, check the following only if there are no qualifying activities

## KyTC BMP Plan for Project PCN 5-9016.00

\_\_\_\_\_ There are no activities for this project as listed in 401 KAR 5:037 Section 2 that require the preparation and implementation of a groundwater protection plan.

The contractor is responsible for the preparation of a plan that addresses the

401 KAR 5:037 Section 3. (3) Elements of site specific groundwater protection plan:

- (a) General information about this project is covered in the Project information;
- (b) Activities that require a groundwater protection plan have been identified above;
- (c) Practices that will protect groundwater from pollution are addressed in section C. Other control measures.
- (d) Implementation schedule – all practices required to prevent pollution of groundwater are to be in place prior to conducting the activity;
- (e) Training is required as a part of the ground water protection plan. All employees of the contractor, sub-contractor and resident engineer personnel will be trained to understand the nature and requirements of this plan as they pertain to their job function(s). Training will be accomplished within one week of employment and annually thereafter. A record of training will be maintained by the contractor with a copy provide to the resident engineer.
- (f) Areas of the project and groundwater plan activities will be inspected as part of the weekly sediment and erosion control inspections
- (g) Certification (see signature page.)



KyTC BMP Plan for Project PCN 5-9016.00

### Sub-Contractor Certification

The following sub-contractor shall be made aware of the BMP plan and responsible for implementation of BMPs identified in this plan as follows:

Subcontractor

Name:  
Address:  
Address:

Phone:

The part of BMP plan this subcontractor is responsible to implement is:

I certify under penalty of law that I understand the terms and conditions of the general Kentucky Pollutant Discharge Elimination System permit that authorizes the storm water discharges, the BMP plan that has been developed to manage the quality of water to be discharged as a result of storm events associated with the construction site activity and management of non-storm water pollutant sources identified as part of this certification.

Signed \_\_\_\_\_ title \_\_\_\_\_, \_\_\_\_\_  
Typed or printed name<sup>1</sup> signature

1. Sub Contractor Note: to be signed by a person who is the owner, a responsible corporate officer, a general partner or the proprietor or a person designated to have the authority to sign reports by such a person in accordance with 401 KAR 5:060 Section 9. This delegation shall be in writing to: Manager, KPDES Branch, Division of Water, 14 Reilly Road, Frankfort Kentucky 40601. Reference the Project Control Number (PCN) and KPDES number when one has been issued.

**PART II**  
**SPECIFICATIONS AND STANDARD DRAWINGS**

### **SPECIFICATIONS REFERENCE**

Any reference in the plans or proposal to previous editions of the *Standard Specifications for Road and Bridge Construction* and *Standard Drawings* are superseded by *Standard Specifications for Road and Bridge Construction, Edition of 2019* and *Standard Drawings, Edition of 2020*.

## **SUPPLEMENTAL SPECIFICATIONS**

The contractor shall use the Supplemental Specifications that are effective at the time of letting.  
The Supplemental Specifications can be found at the following link:

<http://transportation.ky.gov/Construction/Pages/Kentucky-Standard-Specifications.aspx>

## **SPECIAL NOTE FOR PORTABLE CHANGEABLE MESSAGE SIGNS**

This Special Note will apply when indicated on the plans or in the proposal.

**1.0 DESCRIPTION.** Furnish, install, operate, and maintain variable message signs at the locations shown on the plans or designated by the Engineer. Remove and retain possession of variable message signs when they are no longer needed on the project.

### **2.0 MATERIALS.**

**2.1 General.** Use LED Variable Message Signs Class I, II, or III, as appropriate, from the Department's List of Approved Materials.

Unclassified signs may be submitted for approval by the Engineer. The Engineer may require a daytime and nighttime demonstration. The Engineer will make a final decision within 30 days after all required information is received.

#### **2.2 Sign and Controls.** All signs must:

- 1) Provide 3-line messages with each line being 8 characters long and at least 18 inches tall. Each character comprises 35 pixels.
- 2) Provide at least 40 preprogrammed messages available for use at any time. Provide for quick and easy change of the displayed message; editing of the message; and additions of new messages.
- 3) Provide a controller consisting of:
  - a) Keyboard or keypad.
  - b) Readout that mimics the actual sign display. (When LCD or LCD type readout is used, include backlighting and heating or otherwise arrange for viewing in cold temperatures.)
  - c) Non-volatile memory or suitable memory with battery backup for storing pre-programmed messages.
  - d) Logic circuitry to control the sequence of messages and flash rate.
- 4) Provide a serial interface that is capable of supporting complete remote control ability through land line and cellular telephone operation. Include communication software capable of immediately updating the message, providing complete sign status, and allowing message library queries and updates.
- 5) Allow a single person easily to raise the sign to a satisfactory height above the pavement during use, and lower the sign during travel.
- 6) Be Highway Orange on all exterior surfaces of the trailer, supports, and controller cabinet.
- 7) Provide operation in ambient temperatures from -30 to + 120 degrees Fahrenheit during snow, rain and other inclement weather.
- 8) Provide the driver board as part of a module. All modules are interchangeable, and have plug and socket arrangements for disconnection and reconnection. Printed circuit boards associated with driver boards have a conformable coating to protect against moisture.
- 9) Provide a sign case sealed against rain, snow, dust, insects, etc. The lens is UV stabilized clear plastic (polycarbonate, acrylic, or other approved material) angled to prevent glare.
- 10) Provide a flat black UV protected coating on the sign hardware, character PCB, and appropriate lens areas.
- 11) Provide a photocell control to provide automatic dimming.

- 12) Allow an on-off flashing sequence at an adjustable rate.
- 13) Provide a sight to aim the message.
- 14) Provide a LED display color of approximately 590 nm amber.
- 15) Provide a controller that is password protected.
- 16) Provide a security device that prevents unauthorized individuals from accessing the controller.
- 17) Provide the following 3-line messages preprogrammed and available for use when the sign unit begins operation:

|                         |                         |
|-------------------------|-------------------------|
| /KEEP/RIGHT/=>=>=>/     | /MIN/SPEED/**MPH/       |
| /KEEP/LEFT/<<<</        | /ICY/BRIDGE/AHEAD/ /ONE |
| /LOOSE/GRAVEL/AHEAD/    | LANE/BRIDGE/AHEAD/      |
| /RD WORK/NEXT/**MILES/  | /ROUGH/ROAD/AHEAD/      |
| /TWO WAY/TRAFFIC/AHEAD/ | /MERGING/TRAFFIC/AHEAD/ |
| /PAINT/CREW/AHEAD/      | /NEXT/***/MILES/        |
| /REDUCE/SPEED/**MPH/    | /HEAVY/TRAFFIC/AHEAD/   |
| /BRIDGE/WORK/***0 FT/   | /SPEED/LIMIT/**MPH/     |
| /MAX/SPEED/**MPH/       | /BUMP/AHEAD/            |
| /SURVEY/PARTY/AHEAD/    | /TWO/WAY/TRAFFIC/       |

\*Insert numerals as directed by the Engineer.  
Add other messages during the project when required by the Engineer.

**2.3 Power.**

- 1) Design solar panels to yield 10 percent or greater additional charge than sign consumption. Provide direct wiring for operation of the sign or arrow board from an external power source to provide energy backup for 21 days without sunlight and an on-board system charger with the ability to recharge completely discharged batteries in 24 hours.

**3.0 CONSTRUCTION.** Furnish and operate the variable message signs as designated on the plans or by the Engineer. Ensure the bottom of the message panel is a minimum of 7 feet above the roadway in urban areas and 5 feet above in rural areas when operating. Use Class I, II, or III signs on roads with a speed limit less than 55 mph. Use Class I or II signs on roads with speed limits 55 mph or greater.

Maintain the sign in proper working order, including repair of any damage done by others, until completion of the project. When the sign becomes inoperative, immediately repair or replace the sign. Repetitive problems with the same unit will be cause for rejection and replacement.

Use only project related messages and messages directed by the Engineer, unnecessary messages lessen the impact of the sign. Ensure the message is displayed in either one or 2 phases with each phase having no more than 3 lines of text. When no message is needed, but it is necessary to know if the sign is operable, flash only a pixel.

When the sign is not needed, move it outside the clear zone or where the Engineer directs. Variable Message Signs are the property of the Contractor and shall be removed from the project when no longer needed. The Department will not assume ownership of these signs.

**4.0 MEASUREMENT.** The final quantity of Variable Message Sign will be

11

the actual number of individual signs acceptably furnished and operated during the project. The Department will not measure signs replaced due to damage or rejection.

**5.0 PAYMENT.** The Department will pay for the Variable Message Signs at the unit price each. The Department will not pay for signs replaced due to damage or rejection. Payment is full compensation for furnishing all materials, labor, equipment, and service necessary to, operate, move, repair, and maintain or replace the variable message signs. The Department will make payment for the completed and accepted quantities under the following:

| <u>Code</u> | <u>Pay Item</u>                  | <u>Pay Unit</u> |
|-------------|----------------------------------|-----------------|
| 02671       | Portable Changeable Message Sign | Each            |

Effective June 15, 2012

**SPECIAL NOTE FOR LONGITUDINAL PAVEMENT JOINT ADHESIVE**

1. DESCRIPTION. This specification covers the requirements and practices for applying an asphalt adhesive material to the longitudinal joint of the surface course of an asphalt pavement. Apply the adhesive to the face of longitudinal joint between driving lanes for the first lane paved. Then, place and compact the adjacent lane against the treated face to produce a strong, durable, waterproof longitudinal joint.
2. MATERIALS, EQUIPMENT, AND PERSONNEL.

2.1 Joint Adhesive. Provide material conforming to Subsection 2.1.1.

2.1.1 Provide an adhesive conforming to the following requirements:

| Property                     | Specification | Test Procedure       |
|------------------------------|---------------|----------------------|
| Viscosity, 400 ° F (Pa·s)    | 4.0 – 10.0    | ASTM D 4402          |
| Cone Penetration, 77 ° F     | 60 – 100      | ASTM D 5329          |
| Flow, 140 ° F (mm)           | 5.0 max.      | ASTM D 5329          |
| Resilience, 77 ° F (%)       | 30 min.       | ASTM D 5329          |
| Ductility, 77 ° F (cm)       | 30.0 min.     | ASTM D 113           |
| Ductility, 39 ° F (cm)       | 30.0 min.     | ASTM D 113           |
| Tensile Adhesion, 77 ° F (%) | 500 min.      | ASTM D 5329, Type II |
| Softening Point, ° F         | 171 min.      | AASHTO T 53          |
| Asphalt Compatibility        | Pass          | ASTM D 5329          |

Ensure the temperature of the pavement joint adhesive is between 380 and 410 °F when the material is extruded in a 0.125-inch-thick band over the entire face of the longitudinal joint.

2.2. Equipment.

2.2.1 Melter Kettle. Provide an oil-jacketed, double-boiler, melter kettle equipped with any needed agitation and recirculating systems.

2.2.2 Applicator System. Provide a pressure-feed-wand applicator system with an applicator shoe attached.

2.3 Personnel. Ensure a technical representative from the manufacturer of the pavement joint adhesive is present during the initial construction activities and available upon the request of the Engineer.

3. CONSTRUCTION.

3.1 Surface Preparation. Prior to the application of the pavement joint adhesive, ensure the face of the longitudinal joint is thoroughly dry and free from dust or any other debris that would inhibit adhesion. Clean the joint face by the use of compressed air.

Ensure this preparation process occurs shortly before application to prevent the return of debris on the joint face.

3.2 Pavement Joint Adhesive Application. Ensure the ambient temperature is a minimum of 40 ° F during the application of the pavement joint adhesive. Prior to applying the adhesive, demonstrate competence in applying the adhesive according to this note to the satisfaction of the Engineer. Heat the adhesive in the melter kettle to the specified temperature range. Pump the adhesive from the melter kettle through the wand onto the vertical face of the cold joint. Apply the adhesive in a continuous band over the entire face of the longitudinal joint. Do not use excessive material in either thickness or location. Ensure the edge of the extruded adhesive material is flush with the surface of the pavement. Then, place and compact the adjacent lane against the joint face. Remove any excessive material extruded from the joint after compaction (a small line of material may remain).

3.3 Pavement Joint Adhesive Certification. Furnish the joint adhesive's certification to the Engineer stating the material conforms to all requirements herein prior to use.

3.4 Sampling and Testing. The Department will require a random sample of pavement joint adhesive from each manufacturer's lot of material. Extrude two 5 lb. samples of the heated material and forward the sample to the Division of Materials for testing. Reynolds oven bags, turkey size, placed inside small cardboard boxes or cement cylinder molds have been found suitable. Ensure the product temperature is 400°F or below at the time of sampling.

4. MEASUREMENT. The Department will measure the quantity of Pavement Joint Adhesive in linear feet. The Department will not measure for payment any extra materials, labor, methods, equipment, or construction techniques used to satisfy the requirements of this note. The Department will not measure for payment any trial applications of Pavement Joint Adhesive, the cleaning of the joint face, or furnishing and placing the adhesive. The Department will consider all such items incidental to the Pavement Joint Adhesive.
5. PAYMENT. The Department will pay for the Pavement Joint Adhesive at the Contract unit bid price and apply an adjustment for each manufacturer's lot of material based on the degree of compliance as defined in the following schedule. When a sample fails on two or more tests, the Department may add the deductions, but the total deduction will not exceed 100 percent.

11N

| Pavement Joint Adhesive Price Adjustment Schedule |               |          |                      |                      |                      |                |
|---|---------------|----------|----------------------|----------------------|----------------------|----------------|
| Test  | Specification | 100% Pay | 90% Pay              | 80% Pay              | 50% Pay              | 0% Pay         |
| Joint Adhesive Referenced in Subsection 2.1.1     |               |          |                      |                      |                      |                |
| Viscosity, 400 ° F (Pa•s)<br>ASTM D 3236          | 4.0-10.0      | 3.5-10.5 | 3.0-3.4<br>10.6-11.0 | 2.5-2.9<br>11.1-11.5 | 2.0-2.4<br>11.6-12.0 | ≤1.9<br>≥ 12.1 |
| Cone Penetration, 77 ° F<br>ASTM D 5329           | 60-100        | 57-103   | 54-56<br>104-106     | 51-53<br>107-109     | 48-50<br>110-112     | ≤ 47<br>≥ 113  |
| Flow, 140 ° F (mm) ASTM D 5329                    | ≤ 5.0         | ≤ 5.5    | 5.6-6.0              | 6.1-6.5              | 6.6-7.0              | ≥ 7.1          |
| Resilience, 77 ° F (%) ASTM D 5329                | ≥ 30          | ≥ 28     | 26-27                | 24-25                | 22-23                | ≤ 21           |
| Tensile Adhesion, 77 ° F (%) ASTM D 5329          | ≥ 500         | ≥ 490    | 480-489              | 470-479              | 460-469              | ≤ 459          |
| Softening Point, ° F AASHTO T 53                  | ≥ 171         | ≥ 169    | 166-168              | 163-165              | 160-162              | ≤ 159          |
| Ductility, 77 ° F (cm) ASTM D 113                 | ≥ 30.0        | ≥ 29.0   | 28.0-28.9            | 27.0-27.9            | 26.0-26.9            | ≤ 25.9         |
| Ductility, 39 ° F (cm) ASTM D 113                 | ≥ 30.0        | ≥ 29.0   | 28.0-28.9            | 27.0-27.9            | 26.0-26.9            | ≤ 25.9         |

Code  
20071EC

Pay Item  
Joint Adhesive

Pay Unit  
Linear Foot

May 7, 2014

## **PART III**

### **EMPLOYMENT, WAGE AND RECORD REQUIREMENTS**

FHWA-1273 -- Revised May 1, 2012

**REQUIRED CONTRACT PROVISIONS  
FEDERAL-AID CONSTRUCTION CONTRACTS**

- I. General
- II. Nondiscrimination
- III. Nonsegregated Facilities
- IV. Davis-Bacon and Related Act Provisions
- V. Contract Work Hours and Safety Standards Act Provisions
- VI. Subletting or Assigning the Contract
- VII. Safety: Accident Prevention
- VIII. False Statements Concerning Highway Projects
- IX. Implementation of Clean Air Act and Federal Water Pollution Control Act
- X. Compliance with Governmentwide Suspension and Debarment Requirements
- XI. Certification Regarding Use of Contract Funds for Lobbying

3. A breach of any of the stipulations contained in these Required Contract Provisions may be sufficient grounds for withholding of progress payments, withholding of final payment, termination of the contract, suspension / debarment or any other action determined to be appropriate by the contracting agency and FHWA.

4. Selection of Labor: During the performance of this contract, the contractor shall not use convict labor for any purpose within the limits of a construction project on a Federal-aid highway unless it is labor performed by convicts who are on parole, supervised release, or probation. The term Federal-aid highway does not include roadways functionally classified as local roads or rural minor collectors.

**ATTACHMENTS**

A. Employment and Materials Preference for Appalachian Development Highway System or Appalachian Local Access Road Contracts (included in Appalachian contracts only)

**II. NONDISCRIMINATION**

The provisions of this section related to 23 CFR Part 230 are applicable to all Federal-aid construction contracts and to all related construction subcontracts of \$10,000 or more. The provisions of 23 CFR Part 230 are not applicable to material supply, engineering, or architectural service contracts.

**I. GENERAL**

1. Form FHWA-1273 must be physically incorporated in each construction contract funded under Title 23 (excluding emergency contracts solely intended for debris removal). The contractor (or subcontractor) must insert this form in each subcontract and further require its inclusion in all lower tier subcontracts (excluding purchase orders, rental agreements and other agreements for supplies or services).

In addition, the contractor and all subcontractors must comply with the following policies: Executive Order 11246, 41 CFR 60, 29 CFR 1625-1627, Title 23 USC Section 140, the Rehabilitation Act of 1973, as amended (29 USC 794), Title VI of the Civil Rights Act of 1964, as amended, and related regulations including 49 CFR Parts 21, 26 and 27; and 23 CFR Parts 200, 230, and 633.

The applicable requirements of Form FHWA-1273 are incorporated by reference for work done under any purchase order, rental agreement or agreement for other services. The prime contractor shall be responsible for compliance by any subcontractor, lower-tier subcontractor or service provider.

The contractor and all subcontractors must comply with: the requirements of the Equal Opportunity Clause in 41 CFR 60-1.4(b) and, for all construction contracts exceeding \$10,000, the Standard Federal Equal Employment Opportunity Construction Contract Specifications in 41 CFR 60-4.3.

Form FHWA-1273 must be included in all Federal-aid design-build contracts, in all subcontracts and in lower tier subcontracts (excluding subcontracts for design services, purchase orders, rental agreements and other agreements for supplies or services). The design-builder shall be responsible for compliance by any subcontractor, lower-tier subcontractor or service provider.

Note: The U.S. Department of Labor has exclusive authority to determine compliance with Executive Order 11246 and the policies of the Secretary of Labor including 41 CFR 60, and 29 CFR 1625-1627. The contracting agency and the FHWA have the authority and the responsibility to ensure compliance with Title 23 USC Section 140, the Rehabilitation Act of 1973, as amended (29 USC 794), and Title VI of the Civil Rights Act of 1964, as amended, and related regulations including 49 CFR Parts 21, 26 and 27; and 23 CFR Parts 200, 230, and 633.

Contracting agencies may reference Form FHWA-1273 in bid proposal or request for proposal documents, however, the Form FHWA-1273 must be physically incorporated (not referenced) in all contracts, subcontracts and lower-tier subcontracts (excluding purchase orders, rental agreements and other agreements for supplies or services related to a construction contract).

The following provision is adopted from 23 CFR 230, Appendix A, with appropriate revisions to conform to the U.S. Department of Labor (US DOL) and FHWA requirements.

2. Subject to the applicability criteria noted in the following sections, these contract provisions shall apply to all work performed on the contract by the contractor's own organization and with the assistance of workers under the contractor's immediate superintendence and to all work performed on the contract by piecework, station work, or by subcontract.

**1. Equal Employment Opportunity:** Equal employment opportunity (EEO) requirements not to discriminate and to take affirmative action to assure equal opportunity as set forth under laws, executive orders, rules, regulations (28 CFR 35, 29 CFR 1630, 29 CFR 1625-1627, 41 CFR 60 and 49 CFR 27) and orders of the Secretary of Labor as modified by the provisions prescribed herein, and imposed pursuant to 23 U.S.C. 140 shall constitute the EEO and specific affirmative action standards for the contractor's project activities under

this contract. The provisions of the Americans with Disabilities Act of 1990 (42 U.S.C. 12101 et seq.) set forth under 28 CFR 35 and 29 CFR 1630 are incorporated by reference in this contract. In the execution of this contract, the contractor agrees to comply with the following minimum specific requirement activities of EEO:

a. The contractor will work with the contracting agency and the Federal Government to ensure that it has made every good faith effort to provide equal opportunity with respect to all of its terms and conditions of employment and in their review of activities under the contract.

b. The contractor will accept as its operating policy the following statement:

"It is the policy of this Company to assure that applicants are employed, and that employees are treated during employment, without regard to their race, religion, sex, color, national origin, age or disability. Such action shall include: employment, upgrading, demotion, or transfer; recruitment or recruitment advertising; layoff or termination; rates of pay or other forms of compensation; and selection for training, including apprenticeship, pre-apprenticeship, and/or on-the-job training."

**2. EEO Officer:** The contractor will designate and make known to the contracting officers an EEO Officer who will have the responsibility for and must be capable of effectively administering and promoting an active EEO program and who must be assigned adequate authority and responsibility to do so.

**3. Dissemination of Policy:** All members of the contractor's staff who are authorized to hire, supervise, promote, and discharge employees, or who recommend such action, or who are substantially involved in such action, will be made fully cognizant of, and will implement, the contractor's EEO policy and contractual responsibilities to provide EEO in each grade and classification of employment. To ensure that the above agreement will be met, the following actions will be taken as a minimum:

a. Periodic meetings of supervisory and personnel office employees will be conducted before the start of work and then not less often than once every six months, at which time the contractor's EEO policy and its implementation will be reviewed and explained. The meetings will be conducted by the EEO Officer.

b. All new supervisory or personnel office employees will be given a thorough indoctrination by the EEO Officer, covering all major aspects of the contractor's EEO obligations within thirty days following their reporting for duty with the contractor.

c. All personnel who are engaged in direct recruitment for the project will be instructed by the EEO Officer in the contractor's procedures for locating and hiring minorities and women.

d. Notices and posters setting forth the contractor's EEO policy will be placed in areas readily accessible to employees, applicants for employment and potential employees.

e. The contractor's EEO policy and the procedures to implement such policy will be brought to the attention of employees by means of meetings, employee handbooks, or other appropriate means.

**4. Recruitment:** When advertising for employees, the contractor will include in all advertisements for employees the notation: "An Equal Opportunity Employer." All such advertisements will be placed in publications having a large circulation among minorities and women in the area from which the project work force would normally be derived.

a. The contractor will, unless precluded by a valid bargaining agreement, conduct systematic and direct recruitment through public and private employee referral sources likely to yield qualified minorities and women. To meet this requirement, the contractor will identify sources of potential minority group employees, and establish with such identified sources procedures whereby minority and women applicants may be referred to the contractor for employment consideration.

b. In the event the contractor has a valid bargaining agreement providing for exclusive hiring hall referrals, the contractor is expected to observe the provisions of that agreement to the extent that the system meets the contractor's compliance with EEO contract provisions. Where implementation of such an agreement has the effect of discriminating against minorities or women, or obligates the contractor to do the same, such implementation violates Federal nondiscrimination provisions.

c. The contractor will encourage its present employees to refer minorities and women as applicants for employment. Information and procedures with regard to referring such applicants will be discussed with employees.

**5. Personnel Actions:** Wages, working conditions, and employee benefits shall be established and administered, and personnel actions of every type, including hiring, upgrading, promotion, transfer, demotion, layoff, and termination, shall be taken without regard to race, color, religion, sex, national origin, age or disability. The following procedures shall be followed:

a. The contractor will conduct periodic inspections of project sites to insure that working conditions and employee facilities do not indicate discriminatory treatment of project site personnel.

b. The contractor will periodically evaluate the spread of wages paid within each classification to determine any evidence of discriminatory wage practices.

c. The contractor will periodically review selected personnel actions in depth to determine whether there is evidence of discrimination. Where evidence is found, the contractor will promptly take corrective action. If the review indicates that the discrimination may extend beyond the actions reviewed, such corrective action shall include all affected persons.

d. The contractor will promptly investigate all complaints of alleged discrimination made to the contractor in connection with its obligations under this contract, will attempt to resolve such complaints, and will take appropriate corrective action within a reasonable time. If the investigation indicates that the discrimination may affect persons other than the complainant, such corrective action shall include such other persons. Upon completion of each investigation, the contractor will inform every complainant of all of their avenues of appeal.

**6. Training and Promotion:**

a. The contractor will assist in locating, qualifying, and increasing the skills of minorities and women who are

applicants for employment or current employees. Such efforts should be aimed at developing full journey level status employees in the type of trade or job classification involved.

b. Consistent with the contractor's work force requirements and as permissible under Federal and State regulations, the contractor shall make full use of training programs, i.e., apprenticeship, and on-the-job training programs for the geographical area of contract performance. In the event a special provision for training is provided under this contract, this subparagraph will be superseded as indicated in the special provision. The contracting agency may reserve training positions for persons who receive welfare assistance in accordance with 23 U.S.C. 140(a).

c. The contractor will advise employees and applicants for employment of available training programs and entrance requirements for each.

d. The contractor will periodically review the training and promotion potential of employees who are minorities and women and will encourage eligible employees to apply for such training and promotion.

**7. Unions:** If the contractor relies in whole or in part upon unions as a source of employees, the contractor will use good faith efforts to obtain the cooperation of such unions to increase opportunities for minorities and women. Actions by the contractor, either directly or through a contractor's association acting as agent, will include the procedures set forth below:

a. The contractor will use good faith efforts to develop, in cooperation with the unions, joint training programs aimed toward qualifying more minorities and women for membership in the unions and increasing the skills of minorities and women so that they may qualify for higher paying employment.

b. The contractor will use good faith efforts to incorporate an EEO clause into each union agreement to the end that such union will be contractually bound to refer applicants without regard to their race, color, religion, sex, national origin, age or disability.

c. The contractor is to obtain information as to the referral practices and policies of the labor union except that to the extent such information is within the exclusive possession of the labor union and such labor union refuses to furnish such information to the contractor, the contractor shall so certify to the contracting agency and shall set forth what efforts have been made to obtain such information.

d. In the event the union is unable to provide the contractor with a reasonable flow of referrals within the time limit set forth in the collective bargaining agreement, the contractor will, through independent recruitment efforts, fill the employment vacancies without regard to race, color, religion, sex, national origin, age or disability; making full efforts to obtain qualified and/or qualifiable minorities and women. The failure of a union to provide sufficient referrals (even though it is obligated to provide exclusive referrals under the terms of a collective bargaining agreement) does not relieve the contractor from the requirements of this paragraph. In the event the union referral practice prevents the contractor from meeting the obligations pursuant to Executive Order 11246, as amended, and these special provisions, such contractor shall immediately notify the contracting agency.

**8. Reasonable Accommodation for Applicants / Employees with Disabilities:** The contractor must be familiar

with the requirements for and comply with the Americans with Disabilities Act and all rules and regulations established there under. Employers must provide reasonable accommodation in all employment activities unless to do so would cause an undue hardship.

**9. Selection of Subcontractors, Procurement of Materials and Leasing of Equipment:** The contractor shall not discriminate on the grounds of race, color, religion, sex, national origin, age or disability in the selection and retention of subcontractors, including procurement of materials and leases of equipment. The contractor shall take all necessary and reasonable steps to ensure nondiscrimination in the administration of this contract.

a. The contractor shall notify all potential subcontractors and suppliers and lessors of their EEO obligations under this contract.

b. The contractor will use good faith efforts to ensure subcontractor compliance with their EEO obligations.

**10. Assurance Required by 49 CFR 26.13(b):**

a. The requirements of 49 CFR Part 26 and the State DOT's U.S. DOT-approved DBE program are incorporated by reference.

b. The contractor or subcontractor shall not discriminate on the basis of race, color, national origin, or sex in the performance of this contract. The contractor shall carry out applicable requirements of 49 CFR Part 26 in the award and administration of DOT-assisted contracts. Failure by the contractor to carry out these requirements is a material breach of this contract, which may result in the termination of this contract or such other remedy as the contracting agency deems appropriate.

**11. Records and Reports:** The contractor shall keep such records as necessary to document compliance with the EEO requirements. Such records shall be retained for a period of three years following the date of the final payment to the contractor for all contract work and shall be available at reasonable times and places for inspection by authorized representatives of the contracting agency and the FHWA.

a. The records kept by the contractor shall document the following:

(1) The number and work hours of minority and non-minority group members and women employed in each work classification on the project;

(2) The progress and efforts being made in cooperation with unions, when applicable, to increase employment opportunities for minorities and women; and

(3) The progress and efforts being made in locating, hiring, training, qualifying, and upgrading minorities and women;

b. The contractors and subcontractors will submit an annual report to the contracting agency each July for the duration of the project, indicating the number of minority, women, and non-minority group employees currently engaged in each work classification required by the contract work. This information is to be reported on [Form FHWA-1391](#). The staffing data should represent the project work force on board in all or any part of the last payroll period preceding the end of July. If on-the-job training is being required by special provision, the contractor

will be required to collect and report training data. The employment data should reflect the work force on board during all or any part of the last payroll period preceding the end of July.

**III. NONSEGREGATED FACILITIES**

This provision is applicable to all Federal-aid construction contracts and to all related construction subcontracts of \$10,000 or more.

The contractor must ensure that facilities provided for employees are provided in such a manner that segregation on the basis of race, color, religion, sex, or national origin cannot result. The contractor may neither require such segregated use by written or oral policies nor tolerate such use by employee custom. The contractor's obligation extends further to ensure that its employees are not assigned to perform their services at any location, under the contractor's control, where the facilities are segregated. The term "facilities" includes waiting rooms, work areas, restaurants and other eating areas, time clocks, restrooms, washrooms, locker rooms, and other storage or dressing areas, parking lots, drinking fountains, recreation or entertainment areas, transportation, and housing provided for employees. The contractor shall provide separate or single-user restrooms and necessary dressing or sleeping areas to assure privacy between sexes.

**IV. DAVIS-BACON AND RELATED ACT PROVISIONS**

This section is applicable to all Federal-aid construction projects exceeding \$2,000 and to all related subcontracts and lower-tier subcontracts (regardless of subcontract size). The requirements apply to all projects located within the right-of-way of a roadway that is functionally classified as Federal-aid highway. This excludes roadways functionally classified as local roads or rural minor collectors, which are exempt. Contracting agencies may elect to apply these requirements to other projects.

The following provisions are from the U.S. Department of Labor regulations in 29 CFR 5.5 "Contract provisions and related matters" with minor revisions to conform to the FHWA-1273 format and FHWA program requirements.

**1. Minimum wages**

a. All laborers and mechanics employed or working upon the site of the work, will be paid unconditionally and not less often than once a week, and without subsequent deduction or rebate on any account (except such payroll deductions as are permitted by regulations issued by the Secretary of Labor under the Copeland Act (29 CFR part 3)), the full amount of wages and bona fide fringe benefits (or cash equivalents thereof) due at time of payment computed at rates not less than those contained in the wage determination of the Secretary of Labor which is attached hereto and made a part hereof, regardless of any contractual relationship which may be alleged to exist between the contractor and such laborers and mechanics.

Contributions made or costs reasonably anticipated for bona fide fringe benefits under section 1(b)(2) of the Davis-Bacon Act on behalf of laborers or mechanics are considered wages paid to such laborers or mechanics, subject to the provisions

of paragraph 1.d. of this section; also, regular contributions made or costs incurred for more than a weekly period (but not less often than quarterly) under plans, funds, or programs which cover the particular weekly period, are deemed to be constructively made or incurred during such weekly period. Such laborers and mechanics shall be paid the appropriate wage rate and fringe benefits on the wage determination for the classification of work actually performed, without regard to skill, except as provided in 29 CFR 5.5(a)(4). Laborers or mechanics performing work in more than one classification may be compensated at the rate specified for each classification for the time actually worked therein: Provided, That the employer's payroll records accurately set forth the time spent in each classification in which work is performed. The wage determination (including any additional classification and wage rates conformed under paragraph 1.b. of this section) and the Davis-Bacon poster (WH-1321) shall be posted at all times by the contractor and its subcontractors at the site of the work in a prominent and accessible place where it can be easily seen by the workers.

b.(1) The contracting officer shall require that any class of laborers or mechanics, including helpers, which is not listed in the wage determination and which is to be employed under the contract shall be classified in conformance with the wage determination. The contracting officer shall approve an additional classification and wage rate and fringe benefits therefore only when the following criteria have been met:

- (i) The work to be performed by the classification requested is not performed by a classification in the wage determination; and
- (ii) The classification is utilized in the area by the construction industry; and
- (iii) The proposed wage rate, including any bona fide fringe benefits, bears a reasonable relationship to the wage rates contained in the wage determination.

(2) If the contractor and the laborers and mechanics to be employed in the classification (if known), or their representatives, and the contracting officer agree on the classification and wage rate (including the amount designated for fringe benefits where appropriate), a report of the action taken shall be sent by the contracting officer to the Administrator of the Wage and Hour Division, Employment Standards Administration, U.S. Department of Labor, Washington, DC 20210. The Administrator, or an authorized representative, will approve, modify, or disapprove every additional classification action within 30 days of receipt and so advise the contracting officer or will notify the contracting officer within the 30-day period that additional time is necessary.

(3) In the event the contractor, the laborers or mechanics to be employed in the classification or their representatives, and the contracting officer do not agree on the proposed classification and wage rate (including the amount designated for fringe benefits, where appropriate), the contracting officer shall refer the questions, including the views of all interested parties and the recommendation of the contracting officer, to the Wage and Hour Administrator for determination. The Wage and Hour Administrator, or an authorized representative, will issue a determination within 30 days of receipt and so advise the contracting officer or

will notify the contracting officer within the 30-day period that additional time is necessary.

(4) The wage rate (including fringe benefits where appropriate) determined pursuant to paragraphs 1.b.(2) or 1.b.(3) of this section, shall be paid to all workers performing work in the classification under this contract from the first day on which work is performed in the classification.

c. Whenever the minimum wage rate prescribed in the contract for a class of laborers or mechanics includes a fringe benefit which is not expressed as an hourly rate, the contractor shall either pay the benefit as stated in the wage determination or shall pay another bona fide fringe benefit or an hourly cash equivalent thereof.

d. If the contractor does not make payments to a trustee or other third person, the contractor may consider as part of the wages of any laborer or mechanic the amount of any costs reasonably anticipated in providing bona fide fringe benefits under a plan or program. Provided, That the Secretary of Labor has found, upon the written request of the contractor, that the applicable standards of the Davis-Bacon Act have been met. The Secretary of Labor may require the contractor to set aside in a separate account assets for the meeting of obligations under the plan or program.

## 2. Withholding

The contracting agency shall upon its own action or upon written request of an authorized representative of the Department of Labor, withhold or cause to be withheld from the contractor under this contract, or any other Federal contract with the same prime contractor, or any other federally-assisted contract subject to Davis-Bacon prevailing wage requirements, which is held by the same prime contractor, so much of the accrued payments or advances as may be considered necessary to pay laborers and mechanics, including apprentices, trainees, and helpers, employed by the contractor or any subcontractor the full amount of wages required by the contract. In the event of failure to pay any laborer or mechanic, including any apprentice, trainee, or helper, employed or working on the site of the work, all or part of the wages required by the contract, the contracting agency may, after written notice to the contractor, take such action as may be necessary to cause the suspension of any further payment, advance, or guarantee of funds until such violations have ceased.

## 3. Payrolls and basic records

a. Payrolls and basic records relating thereto shall be maintained by the contractor during the course of the work and preserved for a period of three years thereafter for all laborers and mechanics working at the site of the work. Such records shall contain the name, address, and social security number of each such worker, his or her correct classification, hourly rates of wages paid (including rates of contributions or costs anticipated for bona fide fringe benefits or cash equivalents thereof of the types described in section 1(b)(2)(B) of the Davis-Bacon Act), daily and weekly number of hours worked, deductions made and actual wages paid. Whenever the Secretary of Labor has found under 29 CFR 5.5(a)(1)(iv) that the wages of any laborer or mechanic include the amount of any costs reasonably anticipated in providing benefits under a plan or program described in section 1(b)(2)(B) of the Davis-

Bacon Act, the contractor shall maintain records which show that the commitment to provide such benefits is enforceable, that the plan or program is financially responsible, and that the plan or program has been communicated in writing to the laborers or mechanics affected, and records which show the costs anticipated or the actual cost incurred in providing such benefits. Contractors employing apprentices or trainees under approved programs shall maintain written evidence of the registration of apprenticeship programs and certification of trainee programs, the registration of the apprentices and trainees, and the ratios and wage rates prescribed in the applicable programs.

b.(1) The contractor shall submit weekly for each week in which any contract work is performed a copy of all payrolls to the contracting agency. The payrolls submitted shall set out accurately and completely all of the information required to be maintained under 29 CFR 5.5(a)(3)(i), except that full social security numbers and home addresses shall not be included on weekly transmittals. Instead the payrolls shall only need to include an individually identifying number for each employee (e.g., the last four digits of the employee's social security number). The required weekly payroll information may be submitted in any form desired. Optional Form WH-347 is available for this purpose from the Wage and Hour Division Web site at <http://www.dol.gov/esa/whd/forms/wh347instr.htm> or its successor site. The prime contractor is responsible for the submission of copies of payrolls by all subcontractors. Contractors and subcontractors shall maintain the full social security number and current address of each covered worker, and shall provide them upon request to the contracting agency for transmission to the State DOT, the FHWA or the Wage and Hour Division of the Department of Labor for purposes of an investigation or audit of compliance with prevailing wage requirements. It is not a violation of this section for a prime contractor to require a subcontractor to provide addresses and social security numbers to the prime contractor for its own records, without weekly submission to the contracting agency..

(2) Each payroll submitted shall be accompanied by a "Statement of Compliance," signed by the contractor or subcontractor or his or her agent who pays or supervises the payment of the persons employed under the contract and shall certify the following:

(i) That the payroll for the payroll period contains the information required to be provided under §5.5 (a)(3)(ii) of Regulations, 29 CFR part 5, the appropriate information is being maintained under §5.5 (a)(3)(i) of Regulations, 29 CFR part 5, and that such information is correct and complete;

(ii) That each laborer or mechanic (including each helper, apprentice, and trainee) employed on the contract during the payroll period has been paid the full weekly wages earned, without rebate, either directly or indirectly, and that no deductions have been made either directly or indirectly from the full wages earned, other than permissible deductions as set forth in Regulations, 29 CFR part 3;

(iii) That each laborer or mechanic has been paid not less than the applicable wage rates and fringe benefits or cash equivalents for the classification of work performed, as specified in the applicable wage determination incorporated into the contract.

(3) The weekly submission of a properly executed certification set forth on the reverse side of Optional Form WH-347 shall satisfy the requirement for submission of the "Statement of Compliance" required by paragraph 3.b.(2) of this section.

(4) The falsification of any of the above certifications may subject the contractor or subcontractor to civil or criminal prosecution under section 1001 of title 18 and section 231 of title 31 of the United States Code.

c. The contractor or subcontractor shall make the records required under paragraph 3.a. of this section available for inspection, copying, or transcription by authorized representatives of the contracting agency, the State DOT, the FHWA, or the Department of Labor, and shall permit such representatives to interview employees during working hours on the job. If the contractor or subcontractor fails to submit the required records or to make them available, the FHWA may, after written notice to the contractor, the contracting agency or the State DOT, take such action as may be necessary to cause the suspension of any further payment, advance, or guarantee of funds. Furthermore, failure to submit the required records upon request or to make such records available may be grounds for debarment action pursuant to 29 CFR 5.12.

**4. Apprentices and trainees**

a. Apprentices (programs of the USDOL).

Apprentices will be permitted to work at less than the predetermined rate for the work they performed when they are employed pursuant to and individually registered in a bona fide apprenticeship program registered with the U.S. Department of Labor, Employment and Training Administration, Office of Apprenticeship Training, Employer and Labor Services, or with a State Apprenticeship Agency recognized by the Office, or if a person is employed in his or her first 90 days of probationary employment as an apprentice in such an apprenticeship program, who is not individually registered in the program, but who has been certified by the Office of Apprenticeship Training, Employer and Labor Services or a State Apprenticeship Agency (where appropriate) to be eligible for probationary employment as an apprentice.

The allowable ratio of apprentices to journeymen on the job site in any craft classification shall not be greater than the ratio permitted to the contractor as to the entire work force under the registered program. Any worker listed on a payroll at an apprentice wage rate, who is not registered or otherwise employed as stated above, shall be paid not less than the applicable wage rate on the wage determination for the classification of work actually performed. In addition, any apprentice performing work on the job site in excess of the ratio permitted under the registered program shall be paid not less than the applicable wage rate on the wage determination for the work actually performed. Where a contractor is performing construction on a project in a locality other than that in which its program is registered, the ratios and wage rates (expressed in percentages of the journeyman's hourly rate) specified in the contractor's or subcontractor's registered program shall be observed.

Every apprentice must be paid at not less than the rate specified in the registered program for the apprentice's level of progress, expressed as a percentage of the journeymen hourly

rate specified in the applicable wage determination. Apprentices shall be paid fringe benefits in accordance with the provisions of the apprenticeship program. If the apprenticeship program does not specify fringe benefits, apprentices must be paid the full amount of fringe benefits listed on the wage determination for the applicable classification. If the Administrator determines that a different practice prevails for the applicable apprentice classification, fringes shall be paid in accordance with that determination.

In the event the Office of Apprenticeship Training, Employer and Labor Services, or a State Apprenticeship Agency recognized by the Office, withdraws approval of an apprenticeship program, the contractor will no longer be permitted to utilize apprentices at less than the applicable predetermined rate for the work performed until an acceptable program is approved.

b. Trainees (programs of the USDOL).

Except as provided in 29 CFR 5.16, trainees will not be permitted to work at less than the predetermined rate for the work performed unless they are employed pursuant to and individually registered in a program which has received prior approval, evidenced by formal certification by the U.S. Department of Labor, Employment and Training Administration.

The ratio of trainees to journeymen on the job site shall not be greater than permitted under the plan approved by the Employment and Training Administration.

Every trainee must be paid at not less than the rate specified in the approved program for the trainee's level of progress, expressed as a percentage of the journeyman hourly rate specified in the applicable wage determination. Trainees shall be paid fringe benefits in accordance with the provisions of the trainee program. If the trainee program does not mention fringe benefits, trainees shall be paid the full amount of fringe benefits listed on the wage determination unless the Administrator of the Wage and Hour Division determines that there is an apprenticeship program associated with the corresponding journeyman wage rate on the wage determination which provides for less than full fringe benefits for apprentices. Any employee listed on the payroll at a trainee rate who is not registered and participating in a training plan approved by the Employment and Training Administration shall be paid not less than the applicable wage rate on the wage determination for the classification of work actually performed. In addition, any trainee performing work on the job site in excess of the ratio permitted under the registered program shall be paid not less than the applicable wage rate on the wage determination for the work actually performed.

In the event the Employment and Training Administration withdraws approval of a training program, the contractor will no longer be permitted to utilize trainees at less than the applicable predetermined rate for the work performed until an acceptable program is approved.

c. Equal employment opportunity. The utilization of apprentices, trainees and journeymen under this part shall be in conformity with the equal employment opportunity requirements of Executive Order 11246, as amended, and 29 CFR part 30.

d. Apprentices and Trainees (programs of the U.S. DOT).

Apprentices and trainees working under apprenticeship and skill training programs which have been certified by the Secretary of Transportation as promoting EEO in connection with Federal-aid highway construction programs are not subject to the requirements of paragraph 4 of this Section IV. The straight time hourly wage rates for apprentices and trainees under such programs will be established by the particular programs. The ratio of apprentices and trainees to journeymen shall not be greater than permitted by the terms of the particular program.

**5. Compliance with Copeland Act requirements.** The contractor shall comply with the requirements of 29 CFR part 3, which are incorporated by reference in this contract.

**6. Subcontracts.** The contractor or subcontractor shall insert Form FHWA-1273 in any subcontracts and also require the subcontractors to include Form FHWA-1273 in any lower tier subcontracts. The prime contractor shall be responsible for the compliance by any subcontractor or lower tier subcontractor with all the contract clauses in 29 CFR 5.5.

**7. Contract termination: debarment.** A breach of the contract clauses in 29 CFR 5.5 may be grounds for termination of the contract, and for debarment as a contractor and a subcontractor as provided in 29 CFR 5.12.

**8. Compliance with Davis-Bacon and Related Act requirements.** All rulings and interpretations of the Davis-Bacon and Related Acts contained in 29 CFR parts 1, 3, and 5 are herein incorporated by reference in this contract.

**9. Disputes concerning labor standards.** Disputes arising out of the labor standards provisions of this contract shall not be subject to the general disputes clause of this contract. Such disputes shall be resolved in accordance with the procedures of the Department of Labor set forth in 29 CFR parts 5, 6, and 7. Disputes within the meaning of this clause include disputes between the contractor (or any of its subcontractors) and the contracting agency, the U.S. Department of Labor, or the employees or their representatives.

**10. Certification of eligibility.**

a. By entering into this contract, the contractor certifies that neither it (nor he or she) nor any person or firm who has an interest in the contractor's firm is a person or firm ineligible to be awarded Government contracts by virtue of section 3(a) of the Davis-Bacon Act or 29 CFR 5.12(a)(1).

b. No part of this contract shall be subcontracted to any person or firm ineligible for award of a Government contract by virtue of section 3(a) of the Davis-Bacon Act or 29 CFR 5.12(a)(1).

c. The penalty for making false statements is prescribed in the U.S. Criminal Code, 18 U.S.C. 1001.

**V. CONTRACT WORK HOURS AND SAFETY STANDARDS ACT**

The following clauses apply to any Federal-aid construction contract in an amount in excess of \$100,000 and subject to the overtime provisions of the Contract Work Hours and Safety Standards Act. These clauses shall be inserted in addition to the clauses required by 29 CFR 5.5(a) or 29 CFR 4.6. As used in this paragraph, the terms laborers and mechanics include watchmen and guards.

**1. Overtime requirements.** No contractor or subcontractor contracting for any part of the contract work which may require or involve the employment of laborers or mechanics shall require or permit any such laborer or mechanic in any workweek in which he or she is employed on such work to work in excess of forty hours in such workweek unless such laborer or mechanic receives compensation at a rate not less than one and one-half times the basic rate of pay for all hours worked in excess of forty hours in such workweek.

**2. Violation; liability for unpaid wages; liquidated damages.** In the event of any violation of the clause set forth in paragraph (1.) of this section, the contractor and any subcontractor responsible therefor shall be liable for the unpaid wages. In addition, such contractor and subcontractor shall be liable to the United States (in the case of work done under contract for the District of Columbia or a territory, to such District or to such territory), for liquidated damages. Such liquidated damages shall be computed with respect to each individual laborer or mechanic, including watchmen and guards, employed in violation of the clause set forth in paragraph (1.) of this section, in the sum of \$10 for each calendar day on which such individual was required or permitted to work in excess of the standard workweek of forty hours without payment of the overtime wages required by the clause set forth in paragraph (1.) of this section.

**3. Withholding for unpaid wages and liquidated damages.** The FHWA or the contracting agency shall upon its own action or upon written request of an authorized representative of the Department of Labor withhold or cause to be withheld, from any moneys payable on account of work performed by the contractor or subcontractor under any such contract or any other Federal contract with the same prime contractor, or any other federally-assisted contract subject to the Contract Work Hours and Safety Standards Act, which is held by the same prime contractor, such sums as may be determined to be necessary to satisfy any liabilities of such contractor or subcontractor for unpaid wages and liquidated damages as provided in the clause set forth in paragraph (2.) of this section.

**4. Subcontracts.** The contractor or subcontractor shall insert in any subcontracts the clauses set forth in paragraph (1.) through (4.) of this section and also a clause requiring the subcontractors to include these clauses in any lower tier subcontracts. The prime contractor shall be responsible for compliance by any subcontractor or lower tier subcontractor with the clauses set forth in paragraphs (1.) through (4.) of this section.

**VI. SUBLETTING OR ASSIGNING THE CONTRACT**

This provision is applicable to all Federal-aid construction contracts on the National Highway System.

1. The contractor shall perform with its own organization contract work amounting to not less than 30 percent (or a greater percentage if specified elsewhere in the contract) of the total original contract price, excluding any specialty items designated by the contracting agency. Specialty items may be performed by subcontract and the amount of any such specialty items performed may be deducted from the total original contract price before computing the amount of work required to be performed by the contractor's own organization (23 CFR 635.116).

a. The term "perform work with its own organization" refers to workers employed or leased by the prime contractor, and equipment owned or rented by the prime contractor, with or without operators. Such term does not include employees or equipment of a subcontractor or lower tier subcontractor, agents of the prime contractor, or any other assignees. The term may include payments for the costs of hiring leased employees from an employee leasing firm meeting all relevant Federal and State regulatory requirements. Leased employees may only be included in this term if the prime contractor meets all of the following conditions:

- (1) the prime contractor maintains control over the supervision of the day-to-day activities of the leased employees;
- (2) the prime contractor remains responsible for the quality of the work of the leased employees;
- (3) the prime contractor retains all power to accept or exclude individual employees from work on the project; and
- (4) the prime contractor remains ultimately responsible for the payment of predetermined minimum wages, the submission of payrolls, statements of compliance and all other Federal regulatory requirements.

b. "Specialty Items" shall be construed to be limited to work that requires highly specialized knowledge, abilities, or equipment not ordinarily available in the type of contracting organizations qualified and expected to bid or propose on the contract as a whole and in general are to be limited to minor components of the overall contract.

2. The contract amount upon which the requirements set forth in paragraph (1) of Section VI is computed includes the cost of material and manufactured products which are to be purchased or produced by the contractor under the contract provisions.

3. The contractor shall furnish (a) a competent superintendent or supervisor who is employed by the firm, has full authority to direct performance of the work in accordance with the contract requirements, and is in charge of all construction operations (regardless of who performs the work) and (b) such other of its own organizational resources (supervision, management, and engineering services) as the contracting officer determines is necessary to assure the performance of the contract.

4. No portion of the contract shall be sublet, assigned or otherwise disposed of except with the written consent of the contracting officer, or authorized representative, and such consent when given shall not be construed to relieve the contractor of any responsibility for the fulfillment of the contract. Written consent will be given only after the contracting agency has assured that each subcontract is

evidenced in writing and that it contains all pertinent provisions and requirements of the prime contract.

5. The 30% self-performance requirement of paragraph (1) is not applicable to design-build contracts; however, contracting agencies may establish their own self-performance requirements.

**VII. SAFETY: ACCIDENT PREVENTION**

This provision is applicable to all Federal-aid construction contracts and to all related subcontracts.

1. In the performance of this contract the contractor shall comply with all applicable Federal, State, and local laws governing safety, health, and sanitation (23 CFR 635). The contractor shall provide all safeguards, safety devices and protective equipment and take any other needed actions as it determines, or as the contracting officer may determine, to be reasonably necessary to protect the life and health of employees on the job and the safety of the public and to protect property in connection with the performance of the work covered by the contract.

2. It is a condition of this contract, and shall be made a condition of each subcontract, which the contractor enters into pursuant to this contract, that the contractor and any subcontractor shall not permit any employee, in performance of the contract, to work in surroundings or under conditions which are unsanitary, hazardous or dangerous to his/her health or safety, as determined under construction safety and health standards (29 CFR 1926) promulgated by the Secretary of Labor, in accordance with Section 107 of the Contract Work Hours and Safety Standards Act (40 U.S.C. 3704).

3. Pursuant to 29 CFR 1926.3, it is a condition of this contract that the Secretary of Labor or authorized representative thereof, shall have right of entry to any site of contract performance to inspect or investigate the matter of compliance with the construction safety and health standards and to carry out the duties of the Secretary under Section 107 of the Contract Work Hours and Safety Standards Act (40 U.S.C.3704).

**VIII. FALSE STATEMENTS CONCERNING HIGHWAY PROJECTS**

This provision is applicable to all Federal-aid construction contracts and to all related subcontracts.

In order to assure high quality and durable construction in conformity with approved plans and specifications and a high degree of reliability on statements and representations made by engineers, contractors, suppliers, and workers on Federal-aid highway projects, it is essential that all persons concerned with the project perform their functions as carefully, thoroughly, and honestly as possible. Willful falsification, distortion, or misrepresentation with respect to any facts related to the project is a violation of Federal law. To prevent any misunderstanding regarding the seriousness of these and similar acts, Form FHWA-1022 shall be posted on each Federal-aid highway project (23 CFR 635) in one or more places where it is readily available to all persons concerned with the project:

18 U.S.C. 1020 reads as follows:

"Whoever, being an officer, agent, or employee of the United States, or of any State or Territory, or whoever, whether a person, association, firm, or corporation, knowingly makes any false statement, false representation, or false report as to the character, quality, quantity, or cost of the material used or to be used, or the quantity or quality of the work performed or to be performed, or the cost thereof in connection with the submission of plans, maps, specifications, contracts, or costs of construction on any highway or related project submitted for approval to the Secretary of Transportation; or

Whoever knowingly makes any false statement, false representation, false report or false claim with respect to the character, quality, quantity, or cost of any work performed or to be performed, or materials furnished or to be furnished, in connection with the construction of any highway or related project approved by the Secretary of Transportation; or

Whoever knowingly makes any false statement or false representation as to material fact in any statement, certificate, or report submitted pursuant to provisions of the Federal-aid Roads Act approved July 1, 1916, (39 Stat. 355), as amended and supplemented;

Shall be fined under this title or imprisoned not more than 5 years or both."

**IX. IMPLEMENTATION OF CLEAN AIR ACT AND FEDERAL WATER POLLUTION CONTROL ACT**

This provision is applicable to all Federal-aid construction contracts and to all related subcontracts.

By submission of this bid/proposal or the execution of this contract, or subcontract, as appropriate, the bidder, proposer, Federal-aid construction contractor, or subcontractor, as appropriate, will be deemed to have stipulated as follows:

1. That any person who is or will be utilized in the performance of this contract is not prohibited from receiving an award due to a violation of Section 508 of the Clean Water Act or Section 306 of the Clean Air Act.
2. That the contractor agrees to include or cause to be included the requirements of paragraph (1) of this Section X in every subcontract, and further agrees to take such action as the contracting agency may direct as a means of enforcing such requirements.

**X. CERTIFICATION REGARDING DEBARMENT, SUSPENSION, INELIGIBILITY AND VOLUNTARY EXCLUSION**

This provision is applicable to all Federal-aid construction contracts, design-build contracts, subcontracts, lower-tier subcontracts, purchase orders, lease agreements, consultant contracts or any other covered transaction requiring FHWA approval or that is estimated to cost \$25,000 or more – as defined in 2 CFR Parts 180 and 1200.

**1. Instructions for Certification – First Tier Participants:**

- a. By signing and submitting this proposal, the prospective first tier participant is providing the certification set out below.
- b. The inability of a person to provide the certification set out below will not necessarily result in denial of participation in this

covered transaction. The prospective first tier participant shall submit an explanation of why it cannot provide the certification set out below. The certification or explanation will be considered in connection with the department or agency's determination whether to enter into this transaction. However, failure of the prospective first tier participant to furnish a certification or an explanation shall disqualify such a person from participation in this transaction.

c. The certification in this clause is a material representation of fact upon which reliance was placed when the contracting agency determined to enter into this transaction. If it is later determined that the prospective participant knowingly rendered an erroneous certification, in addition to other remedies available to the Federal Government, the contracting agency may terminate this transaction for cause of default.

d. The prospective first tier participant shall provide immediate written notice to the contracting agency to whom this proposal is submitted if any time the prospective first tier participant learns that its certification was erroneous when submitted or has become erroneous by reason of changed circumstances.

e. The terms "covered transaction," "debarred," "suspended," "ineligible," "participant," "person," "principal," and "voluntarily excluded," as used in this clause, are defined in 2 CFR Parts 180 and 1200. "First Tier Covered Transactions" refers to any covered transaction between a grantee or subgrantee of Federal funds and a participant (such as the prime or general contract). "Lower Tier Covered Transactions" refers to any covered transaction under a First Tier Covered Transaction (such as subcontracts). "First Tier Participant" refers to the participant who has entered into a covered transaction with a grantee or subgrantee of Federal funds (such as the prime or general contractor). "Lower Tier Participant" refers any participant who has entered into a covered transaction with a First Tier Participant or other Lower Tier Participants (such as subcontractors and suppliers).

f. The prospective first tier participant agrees by submitting this proposal that, should the proposed covered transaction be entered into, it shall not knowingly enter into any lower tier covered transaction with a person who is debarred, suspended, declared ineligible, or voluntarily excluded from participation in this covered transaction, unless authorized by the department or agency entering into this transaction.

g. The prospective first tier participant further agrees by submitting this proposal that it will include the clause titled "Certification Regarding Debarment, Suspension, Ineligibility and Voluntary Exclusion-Lower Tier Covered Transactions," provided by the department or contracting agency, entering into this covered transaction, without modification, in all lower tier covered transactions and in all solicitations for lower tier covered transactions exceeding the \$25,000 threshold.

h. A participant in a covered transaction may rely upon a certification of a prospective participant in a lower tier covered transaction that is not debarred, suspended, ineligible, or voluntarily excluded from the covered transaction, unless it knows that the certification is erroneous. A participant is responsible for ensuring that its principals are not suspended, debarred, or otherwise ineligible to participate in covered transactions. To verify the eligibility of its principals, as well as the eligibility of any lower tier prospective participants, each participant may, but is not required to, check the Excluded Parties List System website (<https://www.epls.gov/>), which is compiled by the General Services Administration.

i. Nothing contained in the foregoing shall be construed to require the establishment of a system of records in order to render in good faith the certification required by this clause. The knowledge and information of the prospective participant is not required to exceed that which is normally possessed by a prudent person in the ordinary course of business dealings.

j. Except for transactions authorized under paragraph (f) of these instructions, if a participant in a covered transaction knowingly enters into a lower tier covered transaction with a person who is suspended, debarred, ineligible, or voluntarily excluded from participation in this transaction, in addition to other remedies available to the Federal Government, the department or agency may terminate this transaction for cause or default.

\*\*\*\*\*

**2. Certification Regarding Debarment, Suspension, Ineligibility and Voluntary Exclusion – First Tier Participants:**

a. The prospective first tier participant certifies to the best of its knowledge and belief, that it and its principals:

(1) Are not presently debarred, suspended, proposed for debarment, declared ineligible, or voluntarily excluded from participating in covered transactions by any Federal department or agency;

(2) Have not within a three-year period preceding this proposal been convicted of or had a civil judgment rendered against them for commission of fraud or a criminal offense in connection with obtaining, attempting to obtain, or performing a public (Federal, State or local) transaction or contract under a public transaction; violation of Federal or State antitrust statutes or commission of embezzlement, theft, forgery, bribery, falsification or destruction of records, making false statements, or receiving stolen property;

(3) Are not presently indicted for or otherwise criminally or civilly charged by a governmental entity (Federal, State or local) with commission of any of the offenses enumerated in paragraph (a)(2) of this certification; and

(4) Have not within a three-year period preceding this application/proposal had one or more public transactions (Federal, State or local) terminated for cause or default.

b. Where the prospective participant is unable to certify to any of the statements in this certification, such prospective participant shall attach an explanation to this proposal.

**2. Instructions for Certification - Lower Tier Participants:**

(Applicable to all subcontracts, purchase orders and other lower tier transactions requiring prior FHWA approval or estimated to cost \$25,000 or more - 2 CFR Parts 180 and 1200)

a. By signing and submitting this proposal, the prospective lower tier is providing the certification set out below.

b. The certification in this clause is a material representation of fact upon which reliance was placed when this transaction was entered into. If it is later determined that the prospective lower tier participant knowingly rendered an erroneous certification, in addition to other remedies available to the Federal Government, the department, or agency with which

this transaction originated may pursue available remedies, including suspension and/or debarment.

c. The prospective lower tier participant shall provide immediate written notice to the person to which this proposal is submitted if at any time the prospective lower tier participant learns that its certification was erroneous by reason of changed circumstances.

d. The terms "covered transaction," "debarred," "suspended," "ineligible," "participant," "person," "principal," and "voluntarily excluded," as used in this clause, are defined in 2 CFR Parts 180 and 1200. You may contact the person to which this proposal is submitted for assistance in obtaining a copy of those regulations. "First Tier Covered Transactions" refers to any covered transaction between a grantee or subgrantee of Federal funds and a participant (such as the prime or general contract). "Lower Tier Covered Transactions" refers to any covered transaction under a First Tier Covered Transaction (such as subcontracts). "First Tier Participant" refers to the participant who has entered into a covered transaction with a grantee or subgrantee of Federal funds (such as the prime or general contractor). "Lower Tier Participant" refers any participant who has entered into a covered transaction with a First Tier Participant or other Lower Tier Participants (such as subcontractors and suppliers).

e. The prospective lower tier participant agrees by submitting this proposal that, should the proposed covered transaction be entered into, it shall not knowingly enter into any lower tier covered transaction with a person who is debarred, suspended, declared ineligible, or voluntarily excluded from participation in this covered transaction, unless authorized by the department or agency with which this transaction originated.

f. The prospective lower tier participant further agrees by submitting this proposal that it will include this clause titled "Certification Regarding Debarment, Suspension, Ineligibility and Voluntary Exclusion-Lower Tier Covered Transaction," without modification, in all lower tier covered transactions and in all solicitations for lower tier covered transactions exceeding the \$25,000 threshold.

g. A participant in a covered transaction may rely upon a certification of a prospective participant in a lower tier covered transaction that is not debarred, suspended, ineligible, or voluntarily excluded from the covered transaction, unless it knows that the certification is erroneous. A participant is responsible for ensuring that its principals are not suspended, debarred, or otherwise ineligible to participate in covered transactions. To verify the eligibility of its principals, as well as the eligibility of any lower tier prospective participants, each participant may, but is not required to, check the Excluded Parties List System website (<https://www.epls.gov/>), which is compiled by the General Services Administration.

h. Nothing contained in the foregoing shall be construed to require establishment of a system of records in order to render in good faith the certification required by this clause. The knowledge and information of participant is not required to exceed that which is normally possessed by a prudent person in the ordinary course of business dealings.

i. Except for transactions authorized under paragraph e of these instructions, if a participant in a covered transaction knowingly enters into a lower tier covered transaction with a person who is suspended, debarred, ineligible, or voluntarily excluded from participation in this transaction, in addition to other remedies available to the Federal Government, the

department or agency with which this transaction originated may pursue available remedies, including suspension and/or debarment.

\* \* \* \* \*

**Certification Regarding Debarment, Suspension, Ineligibility and Voluntary Exclusion--Lower Tier Participants:**

1. The prospective lower tier participant certifies, by submission of this proposal, that neither it nor its principals is presently debarred, suspended, proposed for debarment, declared ineligible, or voluntarily excluded from participating in covered transactions by any Federal department or agency.

2. Where the prospective lower tier participant is unable to certify to any of the statements in this certification, such prospective participant shall attach an explanation to this proposal.

\* \* \* \* \*

**XI. CERTIFICATION REGARDING USE OF CONTRACT FUNDS FOR LOBBYING**

This provision is applicable to all Federal-aid construction contracts and to all related subcontracts which exceed \$100,000 (49 CFR 20).

1. The prospective participant certifies, by signing and submitting this bid or proposal, to the best of his or her knowledge and belief, that:

a. No Federal appropriated funds have been paid or will be paid, by or on behalf of the undersigned, to any person for influencing or attempting to influence an officer or employee of any Federal agency, a Member of Congress, an officer or employee of Congress, or an employee of a Member of Congress in connection with the awarding of any Federal contract, the making of any Federal grant, the making of any Federal loan, the entering into of any cooperative agreement, and the extension, continuation, renewal, amendment, or modification of any Federal contract, grant, loan, or cooperative agreement.

b. If any funds other than Federal appropriated funds have been paid or will be paid to any person for influencing or attempting to influence an officer or employee of any Federal agency, a Member of Congress, an officer or employee of Congress, or an employee of a Member of Congress in connection with this Federal contract, grant, loan, or cooperative agreement, the undersigned shall complete and submit Standard Form-LLL, "Disclosure Form to Report Lobbying," in accordance with its instructions.

2. This certification is a material representation of fact upon which reliance was placed when this transaction was made or entered into. Submission of this certification is a prerequisite for making or entering into this transaction imposed by 31 U.S.C. 1352. Any person who fails to file the required certification shall be subject to a civil penalty of not less than \$10,000 and not more than \$100,000 for each such failure.

3. The prospective participant also agrees by submitting its bid or proposal that the participant shall require that the language of this certification be included in all lower tier subcontracts, which exceed \$100,000 and that all such recipients shall certify and disclose accordingly.

**ATTACHMENT A - EMPLOYMENT AND MATERIALS  
PREFERENCE FOR APPALACHIAN DEVELOPMENT  
HIGHWAY SYSTEM OR APPALACHIAN LOCAL ACCESS  
ROAD CONTRACTS**

This provision is applicable to all Federal-aid projects funded under the Appalachian Regional Development Act of 1965.

1. During the performance of this contract, the contractor undertaking to do work which is, or reasonably may be, done as on-site work, shall give preference to qualified persons who regularly reside in the labor area as designated by the DOL wherein the contract work is situated, or the subregion, or the Appalachian counties of the State wherein the contract work is situated, except:

a. To the extent that qualified persons regularly residing in the area are not available.

b. For the reasonable needs of the contractor to employ supervisory or specially experienced personnel necessary to assure an efficient execution of the contract work.

c. For the obligation of the contractor to offer employment to present or former employees as the result of a lawful collective bargaining contract, provided that the number of nonresident persons employed under this subparagraph (1c) shall not exceed 20 percent of the total number of employees employed by the contractor on the contract work, except as provided in subparagraph (4) below.

2. The contractor shall place a job order with the State Employment Service indicating (a) the classifications of the laborers, mechanics and other employees required to perform the contract work, (b) the number of employees required in each classification, (c) the date on which the participant estimates such employees will be required, and (d) any other pertinent information required by the State Employment Service to complete the job order form. The job order may be placed with the State Employment Service in writing or by telephone. If during the course of the contract work, the information submitted by the contractor in the original job order is substantially modified, the participant shall promptly notify the State Employment Service.

3. The contractor shall give full consideration to all qualified job applicants referred to him by the State Employment Service. The contractor is not required to grant employment to any job applicants who, in his opinion, are not qualified to perform the classification of work required.

4. If, within one week following the placing of a job order by the contractor with the State Employment Service, the State Employment Service is unable to refer any qualified job applicants to the contractor, or less than the number requested, the State Employment Service will forward a certificate to the contractor indicating the unavailability of applicants. Such certificate shall be made a part of the contractor's permanent project records. Upon receipt of this certificate, the contractor may employ persons who do not normally reside in the labor area to fill positions covered by the certificate, notwithstanding the provisions of subparagraph (1c) above.

5. The provisions of 23 CFR 633.207(e) allow the contracting agency to provide a contractual preference for the use of mineral resource materials native to the Appalachian region.

6. The contractor shall include the provisions of Sections 1 through 4 of this Attachment A in every subcontract for work which is, or reasonably may be, done as on-site work.

**KENTUCKY TRANSPORTATION CABINET  
DEPARTMENT OF HIGHWAYS**

**EMPLOYMENT REQUIREMENTS  
RELATING TO  
NONDISCRIMINATION OF EMPLOYEES  
(APPLICABLE TO FEDERAL-AID SYSTEM CONTRACTS)**

**AN ACT OF THE KENTUCKY GENERAL ASSEMBLY  
TO PREVENT DISCRIMINATION IN EMPLOYMENT**

**KRS CHAPTER 344  
EFFECTIVE JUNE 16, 1972**

The contract on this project, in accordance with KRS Chapter 344, provides that during the performance of this contract, the contractor agrees as follows:

1. The contractor shall not fail or refuse to hire, or shall not discharge any individual, or otherwise discriminate against an individual with respect to his compensation, terms, conditions, or privileges of employment, because of such individual's race, color, religion, national origin, sex, disability or age (forty and above); or limit, segregate, or classify his employees in any way which would deprive or tend to deprive an individual of employment opportunities or otherwise adversely affect his status as an employee, because of such individual's race, color, religion, national origin, sex, disability or age forty (40) and over. The contractor agrees to post in conspicuous places, available to employees and applicants for employment, notices to be provided setting forth the provisions of this nondiscrimination clause.

2. The contractor shall not print or publish or cause to be printed or published a notice or advertisement relating to employment by such an employer or membership in or any classification or referral for employment by the employment agency, indicating any preference, limitation, specification, or discrimination, based on race, color, religion, national origin, sex, or age forty (40) and over, or because the person is a qualified individual with a disability, except that such a notice or advertisement may indicate a preference, limitation, or specification based on religion, national origin, sex, or age forty (40) and over, or because the person is a qualified individual with a disability, when religion, national origin, sex, or age forty (40) and over, or because the person is a qualified individual with a disability, is a bona fide occupational qualification for employment.

3. If the contractor is in control of apprenticeship or other training or retraining, including on-the-job training programs, he shall not discriminate against an individual because of his race, color, religion, national origin, sex, disability or age forty (40) and over, in admission to, or employment in any program established to provide apprenticeship or other training.

4. The contractor will send to each labor union or representative of workers with which he has a collective bargaining agreement or other contract or understanding, a notice to be provided advising the said labor union or workers' representative of the contractor's commitments under this section, and shall post copies of the notice in conspicuous places available to employees and applicants for employment. The contractor will take such action with respect to any subcontract or purchase order as the administering agency may direct as a means of enforcing such provisions, including sanctions for non-compliance.

Revised: January 25, 2017

### Standard Title VI/Non-Discrimination Assurances

During the performance of this contract, the contractor, for itself, its assignees, and successors in interest (hereinafter referred to as the "contractor") agrees as follows:

1. **Compliance with Regulations:** The contractor (hereinafter includes consultants) will comply with the Acts and the Regulations relative to Non-discrimination in Federally-assisted programs of the U.S. Department of Transportation, **Federal Highway Administration**, as they may be amended from time to time, which are herein incorporated by reference and made a part of this contract.
2. **Non-discrimination:** The contractor, with regard to the work performed by it during the contract, will not discriminate on the grounds of race, color, or national origin in the selection and retention of subcontractors, including procurements of materials and leases of equipment. The contractor will not participate directly or indirectly in the discrimination prohibited by the Acts and the Regulations, including employment practices when the contract covers any activity, project, or program set forth in Appendix B of 49 CFR Part 21.
3. **Solicitations for Subcontracts, Including Procurements of Materials and Equipment:** In all solicitations, either by competitive bidding, or negotiation made by the contractor for work to be performed under a subcontract, including procurements of materials, or leases of equipment, each potential subcontractor or supplier will be notified by the contractor of the contractor's obligations under this contract and the Acts and the Regulations relative to Non-discrimination on the grounds of race, color, or national origin.
4. **Information and Reports:** The contractor will provide all information and reports required by the Acts, the Regulations, and directives issued pursuant thereto and will permit access to its books, records, accounts, other sources of information, and its facilities as may be determined by the Recipient or the **Federal Highway Administration** to be pertinent to ascertain compliance with such Acts, Regulations, and instructions. Where any information required of a contractor is in the exclusive possession of another who fails or refuses to furnish the information, the contractor will so certify to the Recipient or the **Federal Highway Administration**, as appropriate, and will set forth what efforts it has made to obtain the information.
5. **Sanctions for Noncompliance:** In the event of a contractor's noncompliance with the Non-discrimination provisions of this contract, the Recipient will impose such contract sanctions as it or the **Federal Highway Administration** may determine to be appropriate, including, but not limited to:
  - a. withholding payments to the contractor under the contract until the contractor complies; and/or
  - b. cancelling, terminating, or suspending a contract, in whole or in part.
6. **Incorporation of Provisions:** The contractor will include the provisions of paragraphs one through six in every subcontract, including procurements of materials and leases of equipment, unless exempt by the Acts, the Regulations and directives issued pursuant thereto. The contractor will take action with respect to any subcontract or procurement as the Recipient or the **Federal Highway Administration** may direct as a means of enforcing such provisions including sanctions for noncompliance. Provided, that if the contractor becomes involved in, or is threatened with litigation by a subcontractor, or supplier because of such direction, the contractor may request the Recipient to enter into any litigation to protect the interests of the Recipient. In addition, the contractor may request the United States to enter into the litigation to protect the interests of the United States.

### Standard Title VI/Non-Discrimination Statutes and Authorities

During the performance of this contract, the contractor, for itself, its assignees, and successors in interest (hereinafter referred to as the “contractor”) agrees to comply with the following non-discrimination statutes and authorities; including but not limited to:

- Title VI of the Civil Rights Act of 1964 (42 U.S.C. § 2000d *et seq.*, 78 stat. 252), (prohibits discrimination on the basis of race, color, national origin); and 49 CFR Part 21;
- The Uniform Relocation Assistance and Real Property Acquisition Policies Act of 1970, (42 U.S.C. § 4601), (prohibits unfair treatment of persons displaced or whose property has been acquired because of Federal or Federal-aid programs and projects);
- Federal-Aid Highway Act of 1973, (23 U.S.C. § 324 *et seq.*), (prohibits discrimination on the basis of sex);
- Section 504 of the Rehabilitation Act of 1973, (29 U.S.C. § 794 *et seq.*), as amended, (prohibits discrimination on the basis of disability); and 49 CFR Part 27;
- The Age Discrimination Act of 1975, as amended, (42 U.S.C. § 6101 *et seq.*), (prohibits discrimination on the basis of age);
- Airport and Airway Improvement Act of 1982, (49 USC § 471, Section 47123), as amended, (prohibits discrimination based on race, creed, color, national origin, or sex);
- The Civil Rights Restoration Act of 1987, (PL 100-209), (Broadened the scope, coverage and applicability of Title VI of the Civil Rights Act of 1964, The Age Discrimination Act of 1975 and Section 504 of the Rehabilitation Act of 1973, by expanding the definition of the terms “programs or activities” to include all of the programs or activities of the Federal-aid recipients, sub-recipients and contractors, whether such programs or activities are Federally funded or not);
- Titles II and III of the Americans with Disabilities Act, which prohibit discrimination on the basis of disability in the operation of public entities, public and private transportation systems, places of public accommodation, and certain testing entities (42 U.S.C. §§ 12131 -- 12189) as implemented by Department of Transportation regulations at 49 C.F.R. parts 37 and 38;
- The Federal Aviation Administration’s Non-discrimination statute (49 U.S.C. § 47123) (prohibits discrimination on the basis of race, color, national origin, and sex);
- Executive Order 12898, Federal Actions to Address Environmental Justice in Minority Populations and Low-Income Populations, which ensures non-discrimination against minority populations by discouraging programs, policies, and activities with disproportionately high and adverse human health or environmental effects on minority and low-income populations;
- Executive Order 13166, Improving Access to Services for Persons with Limited English Proficiency, and resulting agency guidance, national origin discrimination includes discrimination because of limited English proficiency (LEP). To ensure compliance with Title VI, you must take reasonable steps to ensure that LEP persons have meaningful access to your programs (70 Fed. Reg. at 74087 to 74100);
- Title IX of the Education Amendments of 1972, as amended, which prohibits you from discriminating because of sex in education programs or activities (20 U.S.C. 1681 *et seq.*)

## EXECUTIVE BRANCH CODE OF ETHICS

In the 1992 regular legislative session, the General Assembly passed and Governor Brereton Jones signed Senate Bill 63 (codified as KRS 11A), the Executive Branch Code of Ethics, which states, in part:

KRS 11A.040 (7) provides:

No present or former public servant shall, within six (6) months following termination of his office or employment, accept employment, compensation, or other economic benefit from any person or business that contracts or does business with, or is regulated by, the state in matters in which he was directly involved during the last thirty-six (36) months of his tenure. This provision shall not prohibit an individual from returning to the same business, firm, occupation, or profession in which he was involved prior to taking office or beginning his term of employment, or for which he received, prior to his state employment, a professional degree or license, provided that, for a period of six (6) months, he personally refrains from working on any matter in which he was directly involved during the last thirty-six (36) months of his tenure in state government. This subsection shall not prohibit the performance of ministerial functions, including but not limited to filing tax returns, filing applications for permits or licenses, or filing incorporation papers, nor shall it prohibit the former officer or public servant from receiving public funds disbursed through entitlement programs.

KRS 11A.040 (9) states:

A former public servant shall not represent a person or business before a state agency in a matter in which the former public servant was directly involved during the last thirty-six (36) months of his tenure, for a period of one (1) year after the latter of:

- a) The date of leaving office or termination of employment; or
- b) The date the term of office expires to which the public servant was elected.

This law is intended to promote public confidence in the integrity of state government and to declare as public policy the idea that state employees should view their work as a public trust and not as a way to obtain private benefits.

If you have worked for the executive branch of state government within the past six months, you may be subject to the law's prohibitions. The law's applicability may be different if you hold elected office or are contemplating representation of another before a state agency.

Also, if you are affiliated with a firm which does business with the state and which employs former state executive-branch employees, you should be aware that the law may apply to them.

In case of doubt, the law permits you to request an advisory opinion from the Executive Branch Ethics Commission, 3 Fountain Place, Frankfort, Kentucky 40601; telephone (502) 564-7954.

"General Decision Number: KY20210038 10/29/2021

Superseded General Decision Number: KY20200038

State: Kentucky

Construction Type: Highway

Counties: Anderson, Bath, Bourbon, Boyd, Boyle, Bracken, Breckinridge, Bullitt, Carroll, Carter, Clark, Elliott, Fayette, Fleming, Franklin, Gallatin, Grant, Grayson, Greenup, Hardin, Harrison, Henry, Jefferson, Jessamine, Larue, Lewis, Madison, Marion, Mason, Meade, Mercer, Montgomery, Nelson, Nicholas, Oldham, Owen, Robertson, Rowan, Scott, Shelby, Spencer, Trimble, Washington and Woodford Counties in Kentucky.

HIGHWAY CONSTRUCTION PROJECTS (excluding tunnels, building structures in rest area projects & railroad construction; bascule, suspension & spandrel arch bridges designed for commercial navigation, bridges involving marine construction; and other major bridges).

Note: Under Executive Order (EO) 13658, an hourly minimum wage of \$10.95 for calendar year 2021 applies to all contracts subject to the Davis-Bacon Act for which the contract is awarded (and any solicitation was issued) on or after January 1, 2015. If this contract is covered by the EO, the contractor must pay all workers in any classification listed on this wage determination at least \$10.95 per hour (or the applicable wage rate listed on this wage determination, if it is higher) for all hours spent performing on the contract in calendar year 2021. If this contract is covered by the EO and a classification considered necessary for performance of work on the contract does not appear on this wage determination, the contractor must pay workers in that classification at least the wage rate determined through the conformance process set forth in 29 CFR 5.5(a)(1)(ii) (or the EO minimum wage rate, if it is higher than the conformed wage rate). The EO minimum wage rate will be adjusted annually. Please note that this EO applies to the above-mentioned types of contracts entered into by the federal government that are subject to the Davis-Bacon Act itself, but it does not apply to contracts subject only to the Davis-Bacon Related Acts, including those set forth at 29 CFR 5.1(a)(2)-(60). Additional information on contractor requirements and worker protections under the EO is available at [www.dol.gov/whd/govcontracts](http://www.dol.gov/whd/govcontracts).

| Modification Number | Publication Date |
|---------------------|------------------|
| 0                   | 01/01/2021       |
| 1                   | 03/05/2021       |
| 2                   | 10/29/2021       |

\* BRIN0004-003 06/01/2021

BRECKENRIDGE COUNTY

|                 | Rates    | Fringes |
|-----------------|----------|---------|
| BRICKLAYER..... | \$ 29.57 | 15.10   |
| -----           |          |         |

\* BRKY0001-005 06/01/2021

BULLITT, CARROLL, GRAYSON, HARDIN, HENRY, JEFFERSON, LARUE,  
MARION, MEADE, NELSON, OLDHAM, SHELBY, SPENCER, & TRIMBLE  
COUNTIES:

|                           | Rates    | Fringes |
|---------------------------|----------|---------|
| BRICKLAYER.....           | \$ 29.57 | 15.10   |
| -----                     |          |         |
| * BRKY0002-006 06/01/2021 |          |         |

BRACKEN, GALLATIN, GRANT, MASON & ROBERTSON COUNTIES:

|                           | Rates    | Fringes |
|---------------------------|----------|---------|
| BRICKLAYER.....           | \$ 30.87 | 15.87   |
| -----                     |          |         |
| * BRKY0007-004 06/01/2021 |          |         |

BOYD, CARTER, ELLIOT, FLEMING, GREENUP, LEWIS & ROWAN COUNTIES:

|                           | Rates    | Fringes |
|---------------------------|----------|---------|
| BRICKLAYER.....           | \$ 32.03 | 20.05   |
| -----                     |          |         |
| * BRKY0017-004 06/01/2021 |          |         |

ANDERSON, BATH, BOURBON, BOYLE, CLARK, FAYETTE, FRANKLIN,  
HARRISON, JESSAMINE, MADISON, MERCER, MONTGOMERY, NICHOLAS,  
OWEN, SCOTT, WASHINGTON & WOODFORD COUNTIES:

|                         | Rates    | Fringes |
|-------------------------|----------|---------|
| BRICKLAYER.....         | \$ 30.87 | 15.87   |
| -----                   |          |         |
| CARP0064-001 04/01/2020 |          |         |

|                         | Rates    | Fringes |
|-------------------------|----------|---------|
| CARPENTER.....          | \$ 29.81 | 19.96   |
| Diver.....              | \$ 45.09 | 19.96   |
| PILEDRIVERMAN.....      | \$ 30.06 | 19.96   |
| -----                   |          |         |
| ELEC0212-008 06/01/2020 |          |         |

BRACKEN, GALLATIN and GRANT COUNTIES

|                         | Rates    | Fringes |
|-------------------------|----------|---------|
| ELECTRICIAN.....        | \$ 31.30 | 19.72   |
| -----                   |          |         |
| ELEC0212-014 11/25/2019 |          |         |

BRACKEN, GALLATIN & GRANT COUNTIES:

|  | Rates    | Fringes |
|--|----------|---------|
| Sound & Communication<br>Technician..... | \$ 24.35 | 12.09   |
| -----                                    |          |         |
| ELEC0317-012 06/01/2020                  |          |         |

BOYD, CARTER, ELLIOT & ROWAN COUNTIES:

|                            | Rates    | Fringes |
|----------------------------|----------|---------|
| ELECTRICIAN (Wiremen)..... | \$ 35.10 | 26.22   |
| -----                      |          |         |
| ELEC0369-007 05/26/2020    |          |         |

ANDERSON, BATH, BOURBON, BOYLE, BRECKINRIDGE, BULLITT, CARROLL,  
 CLARK, FAYETTE, FRAONKLIN, GRAYSON, HARDIN, HARRISON, HENRY,  
 JEFFERSON, JESSAMINE, LARUE, MADISON, MARION, MEADE, MERCER,  
 MONTGOMERY, NELSON, NICHOLAS, OLDHAM, OWEN, ROBERTSON, SCOTT,  
 SHELBY, SPENCER, TRIMBLE, WASHINGTON, & WOODFORD COUNTIES:

|                         | Rates    | Fringes |
|-------------------------|----------|---------|
| ELECTRICIAN.....        | \$ 33.21 | 17.85   |
| -----                   |          |         |
| ELEC0575-002 11/30/2020 |          |         |

FLEMING, GREENUP, LEWIS & MASON COUNTIES:

|                           | Rates    | Fringes |
|---------------------------|----------|---------|
| ELECTRICIAN.....          | \$ 33.75 | 19.22   |
| -----                     |          |         |
| * ENGI0181-018 07/01/2021 |          |         |

|                          | Rates    | Fringes |
|--------------------------|----------|---------|
| POWER EQUIPMENT OPERATOR |          |         |
| GROUP 1.....             | \$ 34.80 | 17.85   |
| GROUP 2.....             | \$ 31.94 | 17.85   |
| GROUP 3.....             | \$ 32.39 | 17.85   |
| GROUP 4.....             | \$ 31.62 | 17.85   |

OPERATING ENGINEER CLASSIFICATIONS

GROUP 1 - A-Frame Winch Truck; Auto Patrol; Backfiller;  
 Batch Plant; Bituminous Paver; Bituminous Transfer  
 Machine; Boom Cat; Bulldozer; Mechanic; Cableway; Carry-All  
 Scoop; Carry Deck Crane; Central Compressor Plant; Cherry  
 Picker; Clamshell; Concrete Mixer (21 cu. ft. or Over);  
 Concrete Paver; Truck-Mounted Concrete Pump; Core Drill;  
 Crane; Crusher Plant; Derrick; Derrick Boat; Ditching &  
 Trenching Machine; Dragline; Dredge Operator; Dredge  
 Engineer; Elevating Grader & Loaders; Grade-All; Gurrries;  
 Heavy Equipment Robotics Operator/Mechanic; High Lift;  
 Hoe-Type Machine; Hoist (Two or More Drums); Hoisting  
 Engine (Two or More Drums); Horizontal Directional Drill  
 Operator; Hydrocrane; Hyster; KeCal Loader; LeTourneau;  
 Locomotive; Mechanic; Mechanically Operated Laser Screed;  
 Mechanic Welder; Mucking Machine; Motor Scraper; Orangepeel  
 Bucket; Overhead Crane; Piledriver; Power Blade; Pumpcrete;  
 Push Dozer; Rock Spreader, attached to equipment; Rotary  
 Drill; Roller (Bituminous); Rough Terrain Crane; Scarifier;  
 Scoopmobile; Shovel; Side Boom; Subgrader; Tailboom;  
 Telescoping Type Forklift; Tow or Push Boat; Tower Crane  
 (French, German & other types); Tractor Shovel; Truck  
 Crane; Tunnel Mining Machines, including Moles, Shields or  
 similar types of Tunnel Mining Equipment

GROUP 2 - Air Compressor (Over 900 cu. ft. per min.);  
 Bituminous Mixer; Boom Type Tamping Machine; Bull Float;  
 Concrete Mixer (Under 21 cu. ft.); Dredge Engineer;  
 Electric Vibrator; Compactor/Self-Propelled Compactor;

Elevator (One Drum or Buck Hoist); Elevator (When used to Hoist Building Material); Finish Machine; Firemen & Hoist (One Drum); Flexplane; Forklift (Regardless of Lift Height); Form Grader; Joint Sealing Machine; Outboard Motor Boat; Power Sweeper (Riding Type); Roller (Rock); Ross Carrier; Skid Mounted or Trailer Mounted Concrete Pump; Skid Steer Machine with all Attachments; Switchman or Brakeman; Throttle Valve Person; Tractair & Road Widening Trencher; Tractor (50 H.P. or Over); Truck Crane Oiler; Tugger; Welding Machine; Well Points; & Whirley Oiler

GROUP 3 - All Off Road Material Handling Equipment, including Articulating Dump Trucks; Greaser on Grease Facilities servicing Heavy Equipment

GROUP 4 - Bituminous Distributor; Burlap & Curing Machine; Cement Gun; Concrete Saw; Conveyor; Deckhand Oiler; Grout Pump; Hydraulic Post Driver; Hydro Seeder; Mud Jack; Oiler; Paving Joint Machine; Power Form Handling Equipment; Pump; Roller (Earth); Steerman; Tamping Machine; Tractor (Under 50 H.P.); & Vibrator

CRANES - with booms 150 ft. & Over (Including JIB), and where the length of the boom in combination with the length of the piling leads equals or exceeds 150 ft. - \$1.00 over Group 1 rate

EMPLOYEES ASSIGNED TO WORK BELOW GROUND LEVEL ARE TO BE PAID 10% ABOVE BASIC WAGE RATE. THIS DOES NOT APPLY TO OPEN CUT WORK.

-----  
 \* IRON0044-009 06/01/2021

BRACKEN, GALLATIN, GRANT, HARRISON, ROBERTSON, BOURBON (Northern third, including Townships of Jackson, Millersburg, Ruddel Mills & Shawhan); CARROLL (Eastern third, including the Township of Ghent); FLEMING (Western part, excluding Townships of Beechburg, Colfax, Elizaville, Flemingsburg, Flemingsburg Junction, Foxport, Grange City, Hillsboro, Hilltop, Mount Carmel, Muses Mills, Nepton, Pecksridge, Plummers Landing, Plummers Mill, Poplar Plains, Ringos Mills, Tilton & Wallingford); MASON (Western two-thirds, including Townships of Dover, Lewisburg, Mays Lick, Maysville, Minerva, Moranburg, Murphysville, Ripley, Sardis, Shannon, South Ripley & Washington); NICHOLAS (Townships of Barefoot, Barterville, Carlisle, Ellisville, Headquarters, Henryville, Morningglory, Myers & Oakland Mills); OWEN (Townships of Beechwood, Bromley, Fairbanks, Holbrook, Jonesville, Long Ridge, Lusby's Mill, New, New Columbus, New Liberty, Owenton, Poplar Grove, Rockdale, Sanders, Teresita & Wheatley); SCOTT (Northern two-thirds, including Townships of Biddle, Davis, Delaplain, Elmville, Longlick, Muddy Ford, Oxford, Rogers Gap, Sadieville, Skinnersburg & Stonewall)

|                    | Rates    | Fringes |
|--------------------|----------|---------|
| IRONWORKER         |          |         |
| Fence Erector..... | \$ 29.75 | 21.60   |
| Structural.....    | \$ 31.32 | 21.60   |

-----

\* IRON0070-006 06/01/2021

ANDERSON, BOYLE, BRECKINRIDGE, BULLITT, FAYETTE, FRANKLIN,  
 GRAYSON, HARDIN, HENRY, JEFFERSON, JESSAMINE, LARUE, MADISON,  
 MARION, MEADE, MERCER, NELSON, OLDHAM, SHELBY, SPENCER,  
 TRIMBLE, WASHINGTON & WOODFORD  
 BOURBON (Southern two-thirds, including Townships of Austerlity,  
 Centerville, Clintonville, Elizabeth, Hutchison, Littlerock,  
 North Middletown & Paris);  
 CARROLL (Western two-thirds, including Townships of Carrollton,  
 Easterday, English, Locust, Louis, Prestonville & Worthville);  
 CLARK (Western two-thirds, including Townships of Becknerville,  
 Flanagan, Ford, Pine Grove, Winchester & Wyandotte);  
 OWEN (Eastern eighth, including Townships of Glenmary, Gratz,  
 Monterey, Perry Park & Tacketts Mill);  
 SCOTT (Southern third, including Townships of Georgetown, Great  
 Crossing, Newtown, Stampaling Ground & Woodlake);

|                 | Rates    | Fringes |
|-----------------|----------|---------|
| IRONWORKER..... | \$ 31.09 | 23.75   |

\* IRON0769-007 06/01/2021

BATH, BOYD, CARTER, ELLIOTT, GREENUP, LEWIS, MONTGOMERY & ROWAN  
 CLARK (Eastern third, including townships of Bloomingdale,  
 Hunt, Indian Fields, Kiddville, Loglick, Rightangele & Thomson);  
 FLEMING (Townships of Beechburg, Colfax, Elizaville,  
 Flemingsburg, Flemingsburg Junction, Foxport, Grange City,  
 Hillsboro, Hilltop, Mount Carmel, Muses Mills, Nepton,  
 Pecksridge, Plummers Landing, Plummers Mill, Poplar Plains,  
 Ringos Mills, Tilton & Wallingford);  
 MASON (Eastern third, including Townships of Helena, Marshall,  
 Orangeburg, Plumville & Springdale);  
 NICHOLAS (Eastern eighth, including the Township of Moorefield  
 Sprout)

|             | Rates    | Fringes |
|-------------|----------|---------|
| IRONWORKER  |          |         |
| ZONE 1..... | \$ 33.00 | 27.29   |
| ZONE 2..... | \$ 33.40 | 27.29   |
| ZONE 3..... | \$ 35.00 | 27.29   |

ZONE 1 - (no base rate increase) Up to 10 mile radius of  
 Union Hall, 1643 Greenup Ave, Ashland, KY.

ZONE 2 - (add \$0.40 per hour to base rate) 10 to 50 mile  
 radius of Union Hall, 1643 Greenup Ave, Ashland, KY.

ZONE 3 - (add \$2.00 per hour to base rate) 50 mile radius &  
 over of Union Hall, 1643 Greenup Ave, Ashland, KY.

\* LAB00189-003 07/01/2021

BATH, BOURBON, BOYD, BOYLE, BRACKEN, CARTER, CLARK, ELLIOTT,  
 FAYETTE, FLEMING, FRANKLIN, GALLATIN, GRANT, GREENUP, HARRISON,  
 JESSAMINE, LEWIS, MADISON, MASON, MERCER, MONTGOMERY, NICHOLAS,  
 OWEN, ROBERTSON, ROWAN, SCOTT, & WOOLFORD COUNTIES

| Rates | Fringes |
|-------|---------|
|-------|---------|

Laborers:

|              |          |       |
|--------------|----------|-------|
| GROUP 1..... | \$ 23.51 | 16.22 |
| GROUP 2..... | \$ 23.76 | 16.22 |
| GROUP 3..... | \$ 23.81 | 16.22 |
| GROUP 4..... | \$ 24.41 | 16.22 |

LABORERS CLASSIFICATIONS

GROUP 1 - Aging & Curing of Concrete; Asbestos Abatement Worker; Asphalt Plant; Asphalt; Batch Truck Dump; Carpenter Tender; Cement Mason Tender; Cleaning of Machines; Concrete; Demolition; Dredging; Environmental - Nuclear, Radiation, Toxic & Hazardous Waste - Level D; Flagger; Grade Checker; Hand Digging & Hand Back Filling; Highway Marker Placer; Landscaping, Mesh Handler & Placer; Puddler; Railroad; Rip-rap & Grouter; Right-of-Way; Sign, Guard Rail & Fence Installer; Signal Person; Sound Barrier Installer; Storm & Sanitary Sewer; Swamper; Truck Spotter & Dumper; Wrecking of Concrete Forms; General Cleanup

GROUP 2 - Batter Board Man (Sanitary & Storm Sewer); Brickmason Tender; Mortar Mixer Operator; Scaffold Builder; Burner & Welder; Bushhammer; Chain Saw Operator; Concrete Saw Operator; Deckhand Scow Man; Dry Cement Handler; Environmental - Nuclear, Radiation, Toxic & Hazardous Waste - Level C; Forklift Operator for Masonary; Form Setter; Green Concrete Cutting; Hand Operated Grouter & Grinder Machine Operator; Jackhammer; Pavement Breaker; Paving Joint Machine; Pipelayer; Plastic Pipe Fusion; Power Driven Georgia Buggy & Wheel Barrow; Power Post Hole Digger; Precast Manhole Setter; Walk-Behind Tamper; Walk-Behind Trencher; Sand Blaster; Concrete Chipper; Surface Grinder; Vibrator Operator; Wagon Driller

GROUP 3 - Asphalt Luteman & Raker; Gunnite Nozzleman; Gunnite Operator & Mixer; Grout Pump Operator; Side Rail Setter; Rail Paved Ditches; Screw Operator; Tunnel (Free Air); Water Blaster

GROUP 4 - Caisson Worker (Free Air); Cement Finisher; Environmental - Nuclear, Radiation, Toxic & Hazardous Waste - Levels A & B; Miner & Driller (Free Air); Tunnel Blaster; & Tunnel Mucker (Free Air); Directional & Horizontal Boring; Air Track Drillers (All Types); Powdermen & Blasters; Troxler & Concrete Tester if Laborer is Utilized

-----  
 \* LAB00189-008 07/01/2021

ANDERSON, BULLITT, CARROLL, HARDIN, HENRY, JEFFERSON, LARUE, MARION, MEADE, NELSON, OLDHAM, SHELBY, SPENCER, TRIMBLE & WASHINGTON COUNTIES

Rates Fringes

Laborers:

|              |          |       |
|--------------|----------|-------|
| GROUP 1..... | \$ 23.51 | 16.22 |
| GROUP 2..... | \$ 23.76 | 16.22 |
| GROUP 3..... | \$ 23.81 | 16.22 |
| GROUP 4..... | \$ 24.41 | 16.22 |

LABORERS CLASSIFICATIONS

GROUP 1 - Aging & Curing of Concrete; Asbestos Abatement Worker; Asphalt Plant; Asphalt; Batch Truck Dump; Carpenter Tender; Cement Mason Tender; Cleaning of Machines; Concrete; Demolition; Dredging; Environmental - Nuclear, Radiation, Toxic & Hazardous Waste - Level D; Flagperson; Grade Checker; Hand Digging & Hand Back Filling; Highway Marker Placer; Landscaping, Mesh Handler & Placer; Puddler; Railroad; Rip-rap & Grouter; Right-of-Way; Sign, Guard Rail & Fence Installer; Signal Person; Sound Barrier Installer; Storm & Sanitary Sewer; Swamper; Truck Spotter & Dumper; Wrecking of Concrete Forms; General Cleanup

GROUP 2 - Batter Board Man (Sanitary & Storm Sewer); Brickmason Tender; Mortar Mixer Operator; Scaffold Builder; Burner & Welder; Bushhammer; Chain Saw Operator; Concrete Saw Operator; Deckhand Scow Man; Dry Cement Handler; Environmental - Nuclear, Radiation, Toxic & Hazardous Waste - Level C; Forklift Operator for Masonary; Form Setter; Green Concrete Cutting; Hand Operated Grouter & Grinder Machine Operator; Jackhammer; Pavement Breaker; Paving Joint Machine; Pipelayer; Plastic Pipe Fusion; Power Driven Georgia Buggy & Wheel Barrow; Power Post Hole Digger; Precast Manhole Setter; Walk-Behind Tamper; Walk-Behind Trencher; Sand Blaster; Concrete Chipper; Surface Grinder; Vibrator Operator; Wagon Driller

GROUP 3 - Asphalt Luteman & Raker; Gunnite Nozzleman; Gunnite Operator & Mixer; Grout Pump Operator; Side Rail Setter; Rail Paved Ditches; Screw Operator; Tunnel (Free Air); Water Blaster

GROUP 4 - Caisson Worker (Free Air); Cement Finisher; Environmental - Nuclear, Radiation, Toxic & Hazardous Waste - Levels A & B; Miner & Driller (Free Air); Tunnel Blaster; & Tunnel Mucker (Free Air); Directional & Horizontal Boring; Air Track Drillers (All Types); Powdermen & Blasters; Troxler & Concrete Tester if Laborer is Utilized

-----  
 \* LAB00189-009 07/01/2021

BRECKINRIDGE & GRAYSON COUNTIES

|              | Rates    | Fringes |
|--------------|----------|---------|
| Laborers:    |          |         |
| GROUP 1..... | \$ 23.51 | 16.22   |
| GROUP 2..... | \$ 23.76 | 16.22   |
| GROUP 3..... | \$ 23.81 | 16.22   |
| GROUP 4..... | \$ 24.41 | 16.22   |

LABORERS CLASSIFICATIONS

GROUP 1 - Aging & Curing of Concrete; Asbestos Abatement Worker; Asphalt Plant; Asphalt; Batch Truck Dump; Carpenter Tender; Cement Mason Tender; Cleaning of Machines; Concrete; Demolition; Dredging; Environmental - Nuclear, Radiation, Toxic & Hazardous Waste - Level D; Flagperson; Grade Checker; Hand Digging & Hand Back Filling; Highway Marker Placer; Landscaping, Mesh Handler & Placer; Puddler; Railroad; Rip-rap & Grouter; Right-of-Way; Sign, Guard Rail & Fence Installer; Signal Person; Sound Barrier Installer; Storm & Sanitary Sewer; Swamper; Truck Spotter & Dumper; Wrecking of Concrete Forms; General Cleanup

GROUP 2 - Batter Board Man (Sanitary & Storm Sewer);  
 Brickmason Tender; Mortar Mixer Operator; Scaffold Builder;  
 Burner & Welder; Bushhammer; Chain Saw Operator; Concrete  
 Saw Operator; Deckhand Scow Man; Dry Cement Handler;  
 Environmental - Nuclear, Radiation, Toxic & Hazardous Waste  
 - Level C; Forklift Operator for Masonary; Form Setter;  
 Green Concrete Cutting; Hand Operated Grouter & Grinder  
 Machine Operator; Jackhammer; Pavement Breaker; Paving  
 Joint Machine; Pipelayer; Plastic Pipe Fusion; Power Driven  
 Georgia Buggy & Wheel Barrow; Power Post Hole Digger;  
 Precast Manhole Setter; Walk-Behind Tamper; Walk-Behind  
 Trencher; Sand Blaster; Concrete Chipper; Surface Grinder;  
 Vibrator Operator; Wagon Driller

GROUP 3 - Asphalt Luteman & Raker; Gunnite Nozzleman;  
 Gunnite Operator & Mixer; Grout Pump Operator; Side Rail  
 Setter; Rail Paved Ditches; Screw Operator; Tunnel (Free  
 Air); Water Blaster

GROUP 4 - Caisson Worker (Free Air); Cement Finisher;  
 Environmental - Nuclear, Radiation, Toxic & Hazardous Waste  
 - Levels A & B; Miner & Driller (Free Air); Tunnel Blaster;  
 & Tunnel Mucker (Free Air); Directional & Horizontal  
 Boring; Air Track Drillers (All Types); Powdermen &  
 Blasters; Troxler & Concrete Tester if Laborer is Utilized

-----  
 PAIN0012-005 06/11/2005

BATH, BOURBON, BOYLE, CLARK, FAYETTE, FLEMING, FRANKLIN,  
 HARRISON, JESSAMINE, MADISON, MERCER, MONTGOMERY, NICHOLAS,  
 ROBERTSON, SCOTT & WOODFORD COUNTIES:

|  | Rates    | Fringes |
|--|----------|---------|
| PAINTER  |          |         |
| Bridge/Equipment Tender<br>and/or Containment Builder..              | \$ 18.90 | 5.90    |
| Brush & Roller.....  | \$ 21.30 | 5.90    |
| Elevated Tanks;<br>Steeplejack Work; Bridge &<br>Lead Abatement..... | \$ 22.30 | 5.90    |
| Sandblasting &<br>Waterblasting.....                                 | \$ 22.05 | 5.90    |
| Spray.....   | \$ 21.80 | 5.90    |

-----  
 PAIN0012-017 05/01/2015

BRACKEN, GALLATIN, GRANT, MASON & OWEN COUNTIES:

|  | Rates    | Fringes |
|--|----------|---------|
| PAINTER (Heavy & Highway<br>Bridges - Guardrails -<br>Lightpoles - Striping) |          |         |
| Bridge Equipment Tender<br>and Containment Builder.....                      | \$ 20.73 | 9.06    |
| Brush & Roller.....  | \$ 23.39 | 9.06    |
| Elevated Tanks;<br>Steeplejack Work; Bridge &<br>Lead Abatement.....         | \$ 24.39 | 9.06    |
| Sandblasting & Water<br>Blasting.....  | \$ 24.14 | 9.06    |
| Spray.....   | \$ 23.89 | 9.06    |

-----  
 PAIN0118-004 06/01/2018

ANDERSON, BRECKINRIDGE, BULLITT, CARROLL, GRAYSON, HARDIN,  
 HENRY, JEFFERSON, LARUE, MARION, MEADE, NELSON, OLDHAM, SHELBY,  
 SPENCER, TRIMBLE & WASHINGTON COUNTIES:

|   | Rates    | Fringes |
|---|----------|---------|
| PAINTER   |          |         |
| Brush & Roller.....   | \$ 22.00 | 12.52   |
| Spray, Sandblast, Power<br>Tools, Waterblast & Steam<br>Cleaning..... | \$ 23.00 | 12.52   |

-----  
 PAIN1072-003 12/01/2018

BOYD, CARTER, ELLIOTT, GREENUP, LEWIS and ROWAN COUNTIES

|   | Rates    | Fringes |
|---|----------|---------|
| Painters:   |          |         |
| Bridges; Locks; Dams;<br>Tension Towers & Energized<br>Substations..... | \$ 33.33 | 18.50   |
| Power Generating Facilities.  | \$ 30.09 | 18.50   |

-----  
 PLUM0248-003 06/01/2020

BOYD, CARTER, ELLIOTT, GREENUP, LEWIS & ROWAN COUNTIES:

|                              | Rates    | Fringes |
|------------------------------|----------|---------|
| Plumber and Steamfitter..... | \$ 37.05 | 21.48   |

-----  
 PLUM0392-007 06/01/2018

BRACKEN, CARROLL (Eastern Half), GALLATIN, GRANT, MASON, OWEN &  
 ROBERTSON COUNTIES:

|                               | Rates    | Fringes |
|-------------------------------|----------|---------|
| Plumbers and Pipefitters..... | \$ 32.01 | 19.67   |

\* PLUM0502-003 08/01/2021

BRECKINRIDGE, BULLITT, CARROLL (Western Half), FRANKLIN  
 (Western three-fourths), GRAYSON, HARDIN, HENRY, JEFFERSON,  
 LARUE, MARION, MEADE, NELSON, OLDHAM, SHELBY, SPENCER, TRIMBLE &  
 WASHINGTON COUNTIES

|              | Rates    | Fringes |
|--------------|----------|---------|
| PLUMBER..... | \$ 38.07 | 20.78   |

-----  
 SUKY2010-160 10/08/2001

|                | Rates    | Fringes |
|----------------|----------|---------|
| Truck drivers: |          |         |
| GROUP 1.....   | \$ 16.57 | 7.34    |
| GROUP 2.....   | \$ 16.68 | 7.34    |

|              |          |      |
|--------------|----------|------|
| GROUP 3..... | \$ 16.86 | 7.34 |
| GROUP 4..... | \$ 16.96 | 7.34 |

TRUCK DRIVER CLASSIFICATIONS

GROUP 1 - Mobile Batch Truck Tender

GROUP 2 - Greaser; Tire Changer; & Mechanic Tender

GROUP 3 - Single Axle Dump; Flatbed; Semi-trailer or Pole Trailer when used to pull building materials and equipment; Tandem Axle Dump; Distributor; Mixer; & Truck Mechanic

GROUP 4 - Euclid & Other Heavy Earthmoving Equipment & Lowboy; Articulator Cat; 5-Axle Vehicle; Winch & A-Frame when used in transporting materials; Ross Carrier; Forklift when used to transport building materials; & Pavement Breaker

-----  
WELDERS - Receive rate prescribed for craft performing operation to which welding is incidental.

=====  
Note: Executive Order (EO) 13706, Establishing Paid Sick Leave for Federal Contractors applies to all contracts subject to the Davis-Bacon Act for which the contract is awarded (and any solicitation was issued) on or after January 1, 2017. If this contract is covered by the EO, the contractor must provide employees with 1 hour of paid sick leave for every 30 hours they work, up to 56 hours of paid sick leave each year. Employees must be permitted to use paid sick leave for their own illness, injury or other health-related needs, including preventive care; to assist a family member (or person who is like family to the employee) who is ill, injured, or has other health-related needs, including preventive care; or for reasons resulting from, or to assist a family member (or person who is like family to the employee) who is a victim of, domestic violence, sexual assault, or stalking. Additional information on contractor requirements and worker protections under the EO is available at [www.dol.gov/whd/govcontracts](http://www.dol.gov/whd/govcontracts).

Unlisted classifications needed for work not included within the scope of the classifications listed may be added after award only as provided in the labor standards contract clauses (29CFR 5.5 (a) (1) (ii)).

-----  
The body of each wage determination lists the classification and wage rates that have been found to be prevailing for the cited type(s) of construction in the area covered by the wage determination. The classifications are listed in alphabetical order of "identifiers" that indicate whether the particular rate is a union rate (current union negotiated rate for local), a survey rate (weighted average rate) or a union average rate (weighted union average rate).

Union Rate Identifiers

A four letter classification abbreviation identifier enclosed

in dotted lines beginning with characters other than ""SU"" or ""UAVG"" denotes that the union classification and rate were prevailing for that classification in the survey. Example: PLUM0198-005 07/01/2014. PLUM is an abbreviation identifier of the union which prevailed in the survey for this classification, which in this example would be Plumbers. 0198 indicates the local union number or district council number where applicable, i.e., Plumbers Local 0198. The next number, 005 in the example, is an internal number used in processing the wage determination. 07/01/2014 is the effective date of the most current negotiated rate, which in this example is July 1, 2014.

Union prevailing wage rates are updated to reflect all rate changes in the collective bargaining agreement (CBA) governing this classification and rate.

#### Survey Rate Identifiers

Classifications listed under the ""SU"" identifier indicate that no one rate prevailed for this classification in the survey and the published rate is derived by computing a weighted average rate based on all the rates reported in the survey for that classification. As this weighted average rate includes all rates reported in the survey, it may include both union and non-union rates. Example: SULA2012-007 5/13/2014. SU indicates the rates are survey rates based on a weighted average calculation of rates and are not majority rates. LA indicates the State of Louisiana. 2012 is the year of survey on which these classifications and rates are based. The next number, 007 in the example, is an internal number used in producing the wage determination. 5/13/2014 indicates the survey completion date for the classifications and rates under that identifier.

Survey wage rates are not updated and remain in effect until a new survey is conducted.

#### Union Average Rate Identifiers

Classification(s) listed under the UAVG identifier indicate that no single majority rate prevailed for those classifications; however, 100% of the data reported for the classifications was union data. EXAMPLE: UAVG-OH-0010 08/29/2014. UAVG indicates that the rate is a weighted union average rate. OH indicates the state. The next number, 0010 in the example, is an internal number used in producing the wage determination. 08/29/2014 indicates the survey completion date for the classifications and rates under that identifier.

A UAVG rate will be updated once a year, usually in January of each year, to reflect a weighted average of the current negotiated/CBA rate of the union locals from which the rate is based.

-----  
**WAGE DETERMINATION APPEALS PROCESS**

1.) Has there been an initial decision in the matter? This can be:

- \* an existing published wage determination
- \* a survey underlying a wage determination

- \* a Wage and Hour Division letter setting forth a position on a wage determination matter
- \* a conformance (additional classification and rate) ruling

On survey related matters, initial contact, including requests for summaries of surveys, should be with the Wage and Hour Regional Office for the area in which the survey was conducted because those Regional Offices have responsibility for the Davis-Bacon survey program. If the response from this initial contact is not satisfactory, then the process described in 2.) and 3.) should be followed.

With regard to any other matter not yet ripe for the formal process described here, initial contact should be with the Branch of Construction Wage Determinations. Write to:

Branch of Construction Wage Determinations  
Wage and Hour Division  
U.S. Department of Labor  
200 Constitution Avenue, N.W.  
Washington, DC 20210

2.) If the answer to the question in 1.) is yes, then an interested party (those affected by the action) can request review and reconsideration from the Wage and Hour Administrator (See 29 CFR Part 1.8 and 29 CFR Part 7). Write to:

Wage and Hour Administrator  
U.S. Department of Labor  
200 Constitution Avenue, N.W.  
Washington, DC 20210

The request should be accompanied by a full statement of the interested party's position and by any information (wage payment data, project description, area practice material, etc.) that the requestor considers relevant to the issue.

3.) If the decision of the Administrator is not favorable, an interested party may appeal directly to the Administrative Review Board (formerly the Wage Appeals Board). Write to:

Administrative Review Board  
U.S. Department of Labor  
200 Constitution Avenue, N.W.  
Washington, DC 20210

4.) All decisions by the Administrative Review Board are final.

=====

END OF GENERAL DECISION"

Fringe benefit amounts are applicable for all hours worked except when otherwise noted.

No laborer, workman or mechanic shall be paid at a rate less than that of a Journeyman except those classified as bona fide apprentices.

Apprentices or trainees shall be permitted to work as such subject to Administrative Regulations adopted by the Commissioner of Workplace Standards. Copies of these regulations will be furnished upon request from any interested person.

Before using apprentices on the job the contractor shall present to the Contracting Officer written evidence of registration of such employees in a program of a State apprenticeship and training agency approved and recognized by the U. S. Bureau of Apprenticeship and Training. In the absence of such a State agency, the contractor shall submit evidence of approval and registration by the U. S. Bureau of Apprenticeship and Training.

The contractor shall submit to the Contracting Officer, written evidence of the established apprenticeship-journeyman ratios and wage rates in the project area, which will be the basis for establishing such ratios and rates for the project under the applicable contract provisions.

**TO: EMPLOYERS/EMPLOYEES**

**PREVAILING WAGE SCHEDULE:**

**The wages indicated on this wage schedule are the least permitted to be paid for the occupations indicated. When an employee works in more than one classification, the employer must record the number of hours worked in each classification at the prescribed hourly base rate.**

**OVERTIME:**

**Overtime is to be paid to an employee at a rate not less than one and one-half times the basic rate of pay for all hours worked in excess of forty (40) hours in such workweek. Wage violations or questions should be directed to the designated Engineer or the undersigned.**

Director  
Division of Construction Procurement  
Frankfort, Kentucky 40622  
502-564-3500

**NOTICE OF REQUIREMENT FOR AFFIRMATIVE ACTION  
TO ENSURE EQUAL EMPLOYMENT OPPORTUNITY  
(Executive Order 11246)**

1. The Offeror's or Bidder's attention is called to the "Equal Opportunity Clause" and the "Standard Federal Equal Employment Specifications" set forth herein.
2. The goals and timetables for minority and female participation, expressed in percentage terms for the Contractor's aggregate work force in each trade on all construction work in the covered area, are as follows:

| <b>GOALS FOR MINORITY<br/>PARTICIPATION<br/>IN EACH TRADE</b> | <b>GOALS FOR FEMALE<br/>PARTICIPATION IN<br/>EACH TRADE</b> |
|---|---|
| 11.2%   | 6.9%  |

These goals are applicable to all the Contractor's construction work (whether or not it is Federal or federally-assisted) performed in the covered area. If the contractor performs construction work in a geographical area located outside of the covered area, it shall apply the goals established for such geographical area where the work is actually performed. With regard to this second area, the contractor also is subject to the goals for both its federally involved and non-federally involved construction.

The Contractor's compliance with the Executive Order and the regulations in CFR Part 60-4 shall be based on its implementation of the Equal Opportunity Clause, specific affirmative action obligations required by the specifications set forth in 41 CFR 60-4, 3(a), and its efforts to meet the goals. The hours of minority and female employment and training must be substantially uniform throughout the length of the contract, and in each trade, and the contractor shall make a good faith effort to employ minorities and women evenly on each of its projects. The transfer of minority or female employees or trainees from Contractor to Contractor or from project to project for the sole purpose of meeting the Contractor's goals shall be a violation of the contract, the Executive Order and the regulations in 41 CFR Part 60-4. Compliance with the goals will be measured against the total work hours performed.

3. The Contractor shall provide written notification to the Director of the Office of Federal Contract Compliance Programs within ten (10) working days of award of any construction subcontract in excess of \$10,000.00 at any tier for construction work under the contract resulting from this solicitation. The notification shall list the name, address and telephone number of the subcontractor; employer identification number of the subcontractor; estimated dollar amount of the subcontract; estimated starting and completion dates of the subcontract; and the geographical area in which the subcontract is to be performed. The notification shall be mailed to:

**Evelyn Teague, Regional Director  
Office of Federal Contract Compliance Programs  
61 Forsyth Street, SW, Suite 7B75  
Atlanta, Georgia 30303-8609**

4. As used in this Notice, and in the contract resulting from this solicitation, the "**covered area**" is Jefferson County.

**PART IV**  
**INSURANCE**

Refer to  
*Kentucky Standard Specifications for Road and Bridge Construction,*  
current edition

**PART V**  
**BID ITEMS**

### PROPOSAL BID ITEMS

211351

Page 1 of 2

Report Date 10/27/21

#### Section: 0001 - PAVING

| LINE | BID CODE   | ALT | DESCRIPTION                            | QUANTITY | UNIT | UNIT PRIC | FP | AMOUNT |
|------|------------|-----|--|----------|------|-----------|----|--------|
| 0010 | 00001      |     | DGA BASE                               | 212.00   | TON  |           | \$ |        |
| 0020 | 00071      |     | CRUSHED AGGREGATE SIZE NO 57           | 10.00    | TON  |           | \$ |        |
| 0030 | 00190      |     | LEVELING & WEDGING PG64-22             | 143.00   | TON  |           | \$ |        |
| 0040 | 00214      |     | CL3 ASPH BASE 1.00D PG64-22            | 420.00   | TON  |           | \$ |        |
| 0050 | 22906ES403 |     | CL3 ASPH SURF 0.38A PG64-22            | 247.00   | TON  |           | \$ |        |
| 0060 | 24970EC    |     | ASPHALT MATERIAL FOR TACK NON-TRACKING | 2.05     | TON  |           | \$ |        |

#### Section: 0002 - ROADWAY

| LINE | BID CODE | ALT | DESCRIPTION                                 | QUANTITY | UNIT | UNIT PRIC | FP | AMOUNT |
|------|----------|-----|---|----------|------|-----------|----|--------|
| 0070 | 02014    |     | BARRICADE-TYPE III                          | 4.00     | EACH |           | \$ |        |
| 0080 | 02200    |     | ROADWAY EXCAVATION                          | 258.00   | CUYD |           | \$ |        |
| 0090 | 02545    |     | CLEARING AND GRUBBING<br>APPROX. 0.92 ACRES | 1.00     | LS   |           | \$ |        |
| 0100 | 02562    |     | TEMPORARY SIGNS                             | 132.00   | SQFT |           | \$ |        |
| 0110 | 02585    |     | EDGE KEY                                    | 121.00   | LF   |           | \$ |        |
| 0120 | 02603    |     | FABRIC-GEOTEXTILE CLASS 2                   | 898.00   | SQYD |           | \$ |        |
| 0130 | 02650    |     | MAINTAIN & CONTROL TRAFFIC                  | 1.00     | LS   |           | \$ |        |
| 0140 | 02671    |     | PORTABLE CHANGEABLE MESSAGE SIGN            | 3.00     | EACH |           | \$ |        |
| 0150 | 02676    |     | MOBILIZATION FOR MILL & TEXT                | 1.00     | LS   |           | \$ |        |
| 0160 | 02677    |     | ASPHALT PAVE MILLING & TEXTURING            | 167.00   | TON  |           | \$ |        |
| 0170 | 02701    |     | TEMP SILT FENCE                             | 1,430.00 | LF   |           | \$ |        |
| 0180 | 02703    |     | SILT TRAP TYPE A                            | 1.00     | EACH |           | \$ |        |
| 0190 | 02704    |     | SILT TRAP TYPE B                            | 4.00     | EACH |           | \$ |        |
| 0200 | 02705    |     | SILT TRAP TYPE C                            | 1.00     | EACH |           | \$ |        |
| 0210 | 02706    |     | CLEAN SILT TRAP TYPE A                      | 1.00     | EACH |           | \$ |        |
| 0220 | 02707    |     | CLEAN SILT TRAP TYPE B                      | 4.00     | EACH |           | \$ |        |
| 0230 | 02708    |     | CLEAN SILT TRAP TYPE C                      | 1.00     | EACH |           | \$ |        |
| 0240 | 02726    |     | STAKING                                     | 1.00     | LS   |           | \$ |        |
| 0250 | 03271    |     | TREE TRIMMING                               | 200.00   | LF   |           | \$ |        |
| 0260 | 05950    |     | EROSION CONTROL BLANKET                     | 100.00   | SQYD |           | \$ |        |
| 0270 | 05963    |     | INITIAL FERTILIZER                          | .01      | TON  |           | \$ |        |
| 0280 | 05964    |     | MAINTENANCE FERTILIZER                      | .04      | TON  |           | \$ |        |
| 0290 | 05985    |     | SEEDING AND PROTECTION                      | 818.00   | SQYD |           | \$ |        |
| 0300 | 05992    |     | AGRICULTURAL LIMESTONE                      | .51      | TON  |           | \$ |        |
| 0310 | 06511    |     | PAVE STRIPING-TEMP PAINT-6 IN               | 4,350.00 | LF   |           | \$ |        |
| 0320 | 06542    |     | PAVE STRIPING-THERMO-6 IN W                 | 1,646.00 | LF   |           | \$ |        |
| 0330 | 06543    |     | PAVE STRIPING-THERMO-6 IN Y                 | 2,880.00 | LF   |           | \$ |        |
| 0340 | 06545    |     | PAVE STRIPING-THERMO-8 IN Y                 | 67.00    | LF   |           | \$ |        |
| 0350 | 06574    |     | PAVE MARKING-THERMO CURV ARROW              | 2.00     | EACH |           | \$ |        |
| 0360 | 20550ND  |     | SAWCUT PAVEMENT                             | 849.00   | LF   |           | \$ |        |
| 0370 | 21289ED  |     | LONGITUDINAL EDGE KEY                       | 849.00   | LF   |           | \$ |        |
| 0380 | 21813NN  |     | REMOVE AND RELOCATE SHEET SIGNS             | 6.00     | EACH |           | \$ |        |
| 0390 | 22400NN  |     | REMOVE AND RELOCATE SIGN ASSEMBLY           | 6.00     | EACH |           | \$ |        |
| 0400 | 24683ED  |     | PAVE MARKING-THERMO DOTTED LANE<br>EXTEN    | 145.00   | LF   |           | \$ |        |

**PROPOSAL BID ITEMS**

211351

Page 2 of 2

Report Date 10/27/21

**Section: 0003 - WATERLINE**

| LINE | BID CODE | ALT | DESCRIPTION                     | QUANTITY | UNIT | UNIT PRIC | FP | AMOUNT |
|------|----------|-----|---------------------------------|----------|------|-----------|----|--------|
| 0410 | 14037    |     | W PIPE DUCTILE IRON 08 INCH     | 8.00     | LF   |           | \$ |        |
| 0420 | 14039    |     | W PIPE DUCTILE IRON 12 INCH     | 570.00   | LF   |           | \$ |        |
| 0430 | 14074    |     | W PLUG EXISTING MAIN            | 3.00     | EACH |           | \$ |        |
| 0440 | 14080    |     | W SERV PE/PLST LONG SIDE 3/4 IN | 5.00     | EACH |           | \$ |        |
| 0450 | 14095    |     | W TIE-IN 08 INCH                | 1.00     | EACH |           | \$ |        |
| 0460 | 14097    |     | W TIE-IN 12 INCH                | 2.00     | EACH |           | \$ |        |
| 0470 | 14106    |     | W VALVE 08 INCH                 | 1.00     | EACH |           | \$ |        |
| 0480 | 14108    |     | W VALVE 12 INCH                 | 2.00     | EACH |           | \$ |        |

**Section: 0004 - DEMOBILIZATION &/OR MOBILIZATION**

| LINE | BID CODE | ALT | DESCRIPTION    | QUANTITY | UNIT | UNIT PRIC | FP | AMOUNT |
|------|----------|-----|----------------|----------|------|-----------|----|--------|
| 0490 | 02569    |     | DEMOBILIZATION | 1.00     | LS   |           | \$ |        |